

# Pella® Insynctive® Product Guide

Pella® Lifestyle Series Motorized, Integrated Blinds and Shades

---



# Table of Contents

---

## 3 General and Safety Information

- Need Help?
- Have a Home Automation System?
- Warnings

## 4 Product Overview

- Specifications

## 5 Detailed Instructions

- Setting Up Pella® Lifestyle Series Motorized, Integrated Blinds or Shades
- Programming Positions
- Operating Blinds or Shades with Remote
- Tilting Blind Slats
- Pairing to Pella Bridge
- With Home Automation

## 10 Additional Instructions

- Charging Battery in Blinds or Shades
- Care and Maintenance
- Replacing Batteries
- Adding or Deleting a Remote
- "Homing" Blinds or Shades
- Resetting to Factory Defaults

## 13 Troubleshooting

## 14 Inductive Charging Instructions

- Getting Started
- Using the Charger
- LED Color Indicators on Transmitter

## 16 FCC Compliance and Industry Canada

- Limited Warranty

# General and Safety Information

---

## NEED HELP?

For instant access to warranties, troubleshooting information and videos, visit [Pella.CustHelp.com](https://Pella.CustHelp.com) or call **855-473-5524**.

## HAVE A HOME AUTOMATION SYSTEM?

To view a list of compatible systems and contact your home automation provider for further information, visit [ConnectPella.com](https://ConnectPella.com).

## **⚠️ WARNINGS**

**Failure to adhere to the warnings below may result in death, serious injury and/or loss of valuables.**

- Pella® BLINDS and SHADES with Insynctive® technology are not 100% reliable for a variety of reasons. For example, BLINDS and SHADES with Insynctive technology:
  - communicate data wirelessly, and wireless data is susceptible to interference or failure.
  - require proper installation.
  - require a battery with an adequate charge.
  - may be damaged after installation.

Therefore, Pella Insynctive products should not be relied upon in situations where life, safety, and/or protection of valuables are solely dependent on their function. Test each product at least once per year to help ensure proper operation.

- Pella Insynctive products are not a substitute for careful adult supervision of children.
- Keep battery and other small parts out of reach of children. If small parts are swallowed, immediately seek medical help.
- Batteries carry the risk of fire, explosion and burns. Do not disassemble or incinerate.

## Product Overview

---

PELLA® LIFESTYLE SERIES MOTORIZED, INTEGRATED BLINDS or SHADES help to improve the comfort and convenience of your home. BLIND or SHADE may be controlled with a remote, app or a compatible home automation system. The slats of BLIND may be tilted to control privacy or the amount of light entering a room.

BLIND or SHADE includes a power unit which is located at the bottom of the Hinged Glass Panel (HGP) and contains a rechargeable battery. The battery can be charged by:

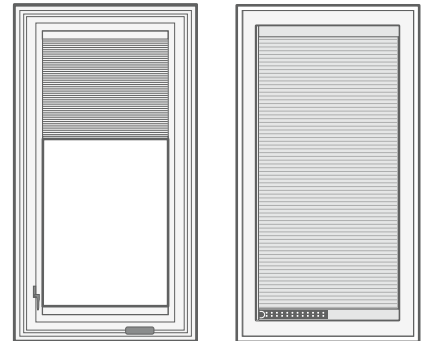

- 1) the solar panel on the exterior side of the unit, requiring approximately 3 hours of direct sunlight a day, OR
- 2) a Pella Lifestyle Series WALL CHARGER that magnetically couples to the HGP. A wire provides power from the battery to the motor located in the headrail of BLIND or SHADE.

### SPECIFICATIONS

**Frequency:** 433.92 MHz (Insynctive®)

**Operating Temperature:** 32° - 120°F (0° - 49°C)

**Operating Humidity:** 5% - 95% RH noncondensing

**Battery:** Rechargeable Lithium Ion battery pack

**Typical Battery Life:** 8 years (may vary with use)

# Pella® Lifestyle Series Motorized, Integrated Blinds or Shades

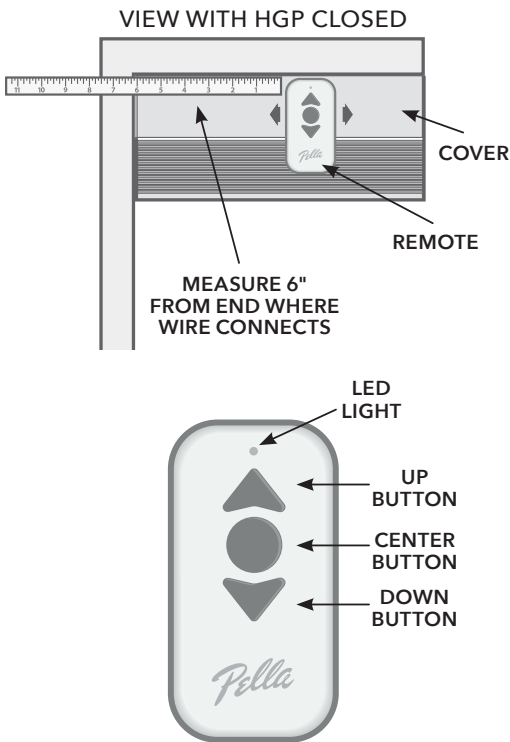

## DETAILED INSTRUCTIONS

### 1. Get started.

- To unpack BLIND or SHADE, remove the cardboard corner protector and bands that secure BLIND or SHADE. It is not necessary to open the Hinge Glass Panel (HGP) to unpack your BLIND or SHADE.
- Unpack REMOTE.

### 2. Prepare SINGLE-CHANNEL REMOTE.

- Slide the battery cover in the direction of the arrow on the cover.
- Remove battery tab.
- Ensure battery is fully seated.
- Slide the battery cover back into closed position.

### 3. Pair REMOTE to Pella Lifestyle Series motorized BLIND or SHADE.

- Hold REMOTE up to top cover approximately 6" from the end to activate pair mode. Move remote from side to side while pressed up against the glass. BLIND or SHADE will make a quick up/down motion to indicate it's in pair mode.
- Press and hold the Up button on REMOTE until BLIND or SHADE completes a quick up/down motion. **NOTE:** Up/down motion confirms that REMOTE was successfully paired.

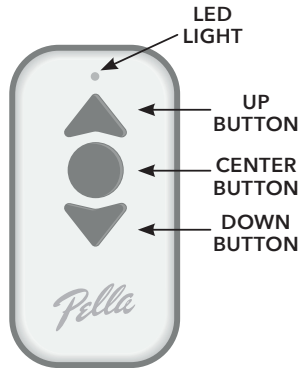

#### 4. Test BLIND or SHADE.

- Press the Down button to move BLIND or SHADE down.
- Press the Up button to move BLIND or SHADE up.

#### 5. Set up BLIND or SHADE.

Complete the following steps to set up BLIND or SHADE.

##### Program upper position.

- Touch the top end of REMOTE to BLIND or SHADE cover approximately 6" from the end where the wire connects. Move REMOTE back and forth slowly until BLIND or SHADE completes a quick up/down motion to indicate BLIND or SHADE has entered program mode.
- Simultaneously press and hold the Center and Up buttons until BLIND or SHADE completes a quick up/down motion. This will require the buttons to be pressed for about 5 seconds. The light on REMOTE will begin blinking when the buttons are released to acknowledge that REMOTE is in program mode.
- Press the Up or Down button on REMOTE to move BLIND or SHADE bottom rail to the desired position.
- Press and hold the Center button until BLIND or SHADE makes a quick up/down movement. This should take about 3 seconds. The light on REMOTE will stop blinking.

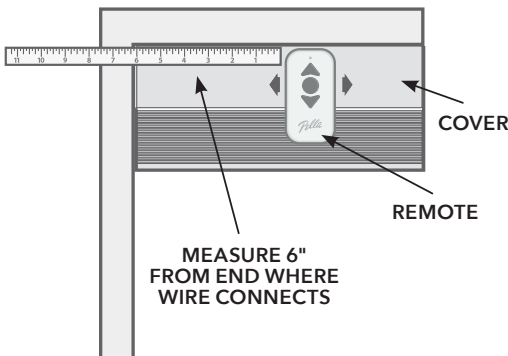

# Pella® Lifestyle Series Motorized, Integrated Blinds or Shades (continued)

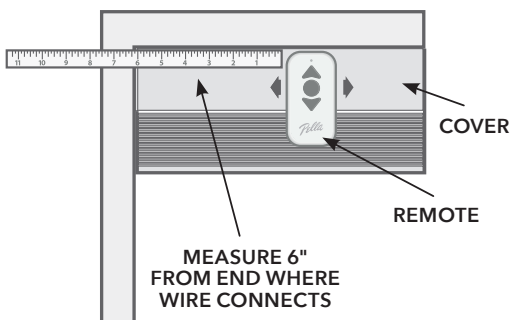
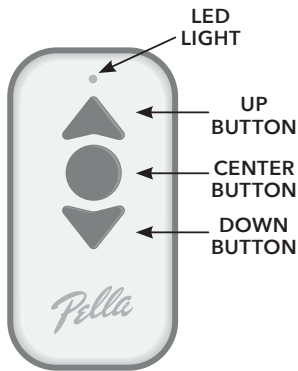
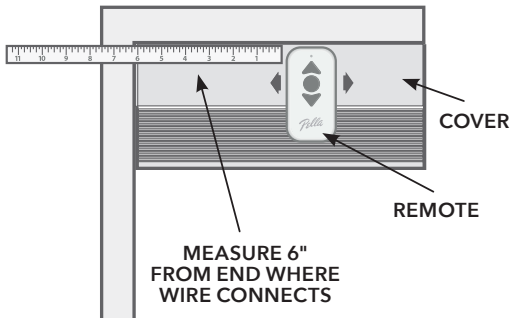

## Program user position.

- Touch the top end of REMOTE to BLIND or SHADE cover approximately 6" from the end where the wire connects. Move REMOTE back and forth slowly until BLIND or SHADE completes a quick up/down motion to indicate BLIND or SHADE has entered program mode.
- Simultaneously press and hold the Up and Down buttons until BLIND or SHADE completes a quick up/down motion. This will require the buttons to be pressed for about 5 seconds. The light on REMOTE will begin blinking when the buttons are released to acknowledge that REMOTE is in program mode.
- Press the Up or Down button on REMOTE to move BLIND or SHADE bottom rail to the desired position.
- Press and hold the Center button until BLIND or SHADE makes a quick up/down movement. This should take about 3 seconds. The light on REMOTE will stop blinking.

## Program lower position.

- Touch the top end of REMOTE to BLIND or SHADE cover approximately 6" from the end where the wire connects. Move REMOTE back and forth slowly until BLIND or SHADE completes a quick up/down motion to indicate BLIND or SHADE has entered program mode.
- Simultaneously press and hold the Center and Down buttons until BLIND or SHADE completes a quick up/down motion. This will require the buttons to be pressed for about 5 seconds. The light on REMOTE will begin blinking when the buttons are released to acknowledge that REMOTE is in program mode.
- Press the Up or Down button on REMOTE to move BLIND or SHADE bottom rail to the desired position.
- Press and hold the Center button until BLIND or SHADE makes a quick up/down movement. This should take about 3 seconds. The light on REMOTE will stop blinking.

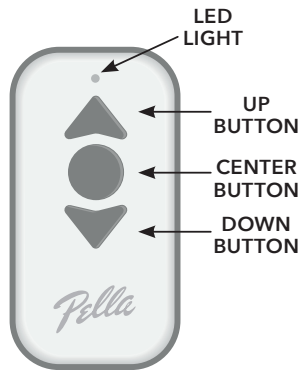

## OPERATING BLIND OR SHADE WITH REMOTE

- Press and release Up button: Pressing the Up button for less than 1 second will cause BLIND or SHADE to automatically move to the upper position that has been programmed by the user.
- Press and hold Up button: Pressing the Up button for longer than 1 second will cause BLIND or SHADE to move up until the button is released or until the shade reaches the fully opened position.
- Press and release Center button: Pressing the Center button for less than 1 second will cause BLIND or SHADE to automatically move to the user position.
- Press and release Down button: Pressing the Down button for less than 1 second will cause BLIND or SHADE to automatically move to the lower position that has been programmed by the user.
- Press and hold Down button: Pressing the Down button for longer than 1 second will cause BLIND or SHADE to move down until the button is released or until the shade reaches the fully closed position.
- While BLIND or SHADE is moving to a position, it may be stopped by pressing either of the other two buttons. For example, if the Center button is pressed to move to the user position, BLIND or SHADE will stop moving if the Up or Down button is pressed.

## TILTING BLIND SLATS

- To enter tilt mode, press and hold the Center button on REMOTE until light turns solid red.
- Press and release the Up button to rotate the slats up.
- Press and release the Down button to rotate the slats down.
- REMOTE will exit tilt mode after 10 seconds of no activity or when Center button is pressed and held until the light turns off.



# Pella® Lifestyle Series Motorized, Integrated Blinds or Shades (continued)

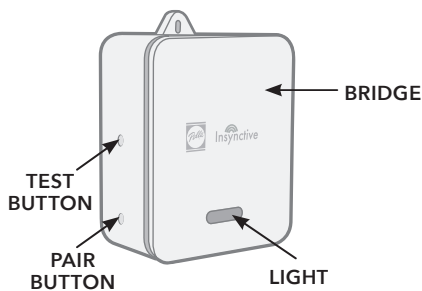
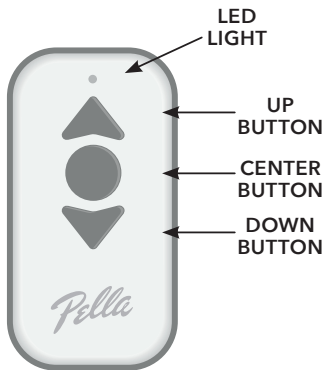

## PAIRING TO PELLA® INSYNCTIVE® BRIDGE

By pairing to BRIDGE, you can control your BLIND or SHADE from virtually anywhere using the Pella Insynctive app. Download the Pella Insynctive app from the app store appropriate to your device.

- Press and hold the pair button until the light begins flashing orange. The pair button is the bottom button located on the side of the BRIDGE. The BRIDGE is now ready to pair Insynctive products.
- Touch the top end of REMOTE to BLIND or SHADE cover approximately 6" from the end where the wire connects. Move REMOTE back and forth slowly until BLIND or SHADE completes a quick up/down motion to indicate BLIND or SHADE has entered pair mode.
- Press and release the Center button on REMOTE three times within 5 seconds. BRIDGE light will begin blinking green. BRIDGE will issue a long tone to indicate successful pairing.

## WITH HOME AUTOMATION

For a list of compatible home automation systems or pairing instructions, visit [ConnectPella.com](http://ConnectPella.com).

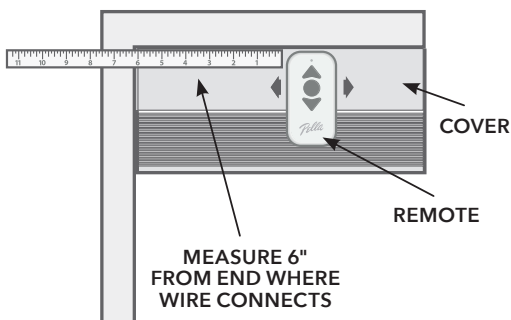

# Additional Instructions

---

## **CHARGING BATTERY IN BLINDS AND SHADES**

The solar panel requires approximately 3 hours of direct sunlight each day to charge the battery for BLIND or SHADE operation solely by power generated from the exterior solar panel. Additional charging is necessary when the solar panel on the exterior of the unit does not receive adequate sunlight.

- See Inductive Charging Instructions starting on pg 14.

## **CARE AND MAINTENANCE**

### **Cleaning Integrated Aluminum Blinds**

- First make sure BLIND is in the horizontal (opened) position. To remove dust, use a vacuum cleaner with an upholstery brush attachment. You can remove smudges or fingerprints with a damp cloth.

### **Cleaning Integrated Cellular Shades**

- Begin by making sure SHADE is fully extended. To remove dust, use a vacuum cleaner with an upholstery brush attachment. Smudges or fingerprints can be carefully removed with a damp cloth. Never use cleaners with ammonia – they will damage the fabric. If there are any exposed threads, trim them and seal them with a fray-check solution (available at most fabric stores) to reduce fraying. Once SHADE is clean and dry, raise SHADE.

### **Cleaning Solar Cell**

- For optimal performance of the solar cell, keep the exterior glass surface clean of dust and dirt. It is recommended that the exterior glass surface be cleaned every six months or whenever dirt noticeably builds up on the glass. Use an ammonia-free glass cleaner and soft cloth.

## Additional Instructions (continued)

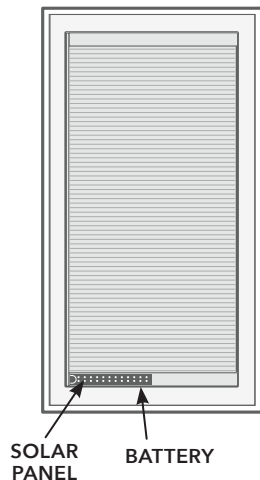

### REPLACING BATTERIES

The battery pack used in this product is recharged by the solar cell or by using the Pella® Lifestyle WALL CHARGER. Battery life is dependent upon a number of factors such as number of charge/discharge cycles and average temperature in the environment. Battery life is expected to exceed five years in most applications. When the battery reaches the end of its life, it will lose its charge quickly and will require charging with the wall charger on a more frequent basis. Contact your local Pella sales representative to purchase a replacement battery.



**WARNING:** Batteries carry the risk of fire, explosion and burns. Do not disassemble or incinerate. Failure to change battery properly when low will impair BLIND or SHADE performance.

### IMPORTANT NOTES:

- BLIND or SHADE does not need to be paired to REMOTE or BRIDGE following a battery change.
- Properly dispose of used batteries based on your local requirements. A best practice is to dispose of batteries at your local home chemical collection center. **California Only:** Contains perchlorate material. See [dtsc.ca.gov/hazardouswaste/perchlorate](http://dtsc.ca.gov/hazardouswaste/perchlorate) for any special handling regulations.

### ADDING AN ADDITIONAL REMOTE OR DELETING A REMOTE

These procedures may be used to pair or delete a REMOTE from BLIND or SHADE. A total of eight REMOTES may be paired to BLIND or SHADE.

- Touch the top end of REMOTE to BLIND or SHADE cover approximately 6" from the end where the wire connects. Move REMOTE back and forth slowly until BLIND or SHADE completes a quick up/down motion to indicate that BLIND or SHADE has entered pair mode.
  - To add a new REMOTE, press and hold the Up button on new REMOTE until BLIND or SHADE completes a quick up/down motion to acknowledge that new REMOTE was successfully paired.
  - To delete REMOTE, press and hold the Down button on REMOTE until BLIND or SHADE completes a quick up/down motion to acknowledge that REMOTE was successfully deleted.

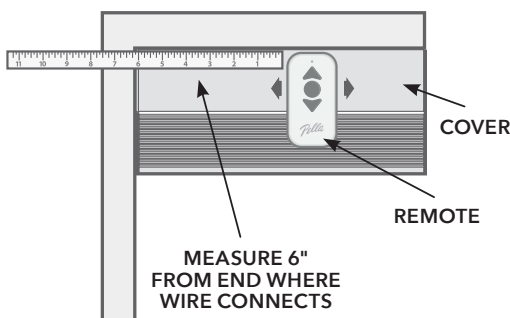

## Additional Instructions (continued)

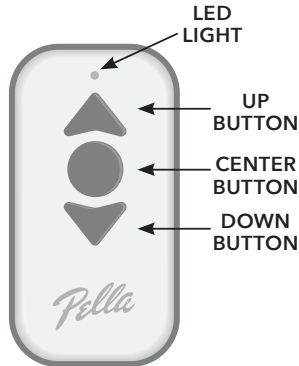

### “HOMING” THE BLIND OR SHADE

Over time, you may notice that the fully opened position for raise-and-lower BLINDS or bottom-up SHADES or the fully closed position for top-down SHADES has drifted. This is due to normal wear and use of BLIND or SHADE and can be corrected by homing BLIND or SHADE. The homing process will cause BLIND or SHADE to move up until it is fully compressed. BLIND or SHADE then resets the position. To initiate the homing process, press and hold the Up button on REMOTE until BLIND or SHADE reaches the top point of travel, then release the button. Press and hold the Up button for about 5 seconds until BLIND or SHADE begins to move up. BLIND or SHADE will stop moving when fully compressed and will reset the fully opened or closed position. May take multiple homing cycles to fully home Blind or Shade.

### PROGRAMMING POSITIONS (OPTIONAL)

REMOTE may be used to program up to three positions to motorized BLIND or SHADE including an upper position, user position and lower position. Once placed into program mode, REMOTE will stay in program mode until the programming process is completed, or REMOTE will automatically exit program mode if no buttons are pressed for 1 minute or if battery is removed and reinserted.

### RESETTING TO FACTORY DEFAULTS

This procedure will reset all BLIND or SHADE positions to factory default settings.

- Open the HGP.
- Locate the small hole in the top cover about 4" from the end where the wire connects. (see photo)
- Insert a paper clip or other small tool into the hole, and depress the reset switch for about 3 seconds. (see photo)
- BLIND or SHADE will move to top position to acknowledge successful reset. (see photo)

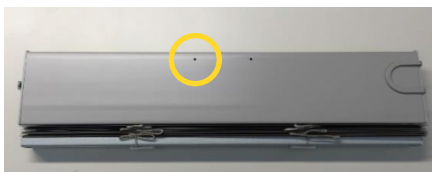

Locate the small hole in the top cover about 4" from the end where the wire connects



For a video walk-thru showing how to reset Blinds or Shades to their factory resets, use your phone's camera to capture this QR code.



BLIND or SHADE will move to top position, to acknowledge successful reset

# Troubleshooting

PROBLEM	CAUSE AND POSSIBLE SOLUTION
<p>BLIND or SHADE is moving slowly.</p>	<ul style="list-style-type: none"> <li>• Batteries are low. Batteries may be recharged with WALL CHARGER. If problem persists after charging batteries for 12 hours, contact your local Pella sales representative to purchase a replacement battery.</li> <li>• If the light on REMOTE is blinking, BLIND or SHADE is in program mode and runs at a slower rate to allow for easier movement of BLIND or SHADE to the desired position. Wait 2 minutes, and BLIND or SHADE and REMOTE will exit program mode.</li> </ul>
<p>BLIND or SHADE will not move.</p>	<ul style="list-style-type: none"> <li>• Verify that all connectors are firmly plugged in at BLIND or SHADE cover and power unit.</li> <li>• BLIND or SHADE may be in pair mode. Wait 2 minutes and BLIND or SHADE will exit pair mode, or press and hold the Up button on REMOTE until BLIND or SHADE makes a quick up/down motion to exit pair mode.</li> <li>• Batteries are dead in BLIND, SHADE or REMOTE. If REMOTE light does not come on when buttons are pressed, replace REMOTE battery. Otherwise, try charging BLIND or SHADE with WALL CHARGER.</li> <li>• Temperature in the Hinged Glass Panel (HGP) may have exceeded 140°F. The motor will function once the HGP cools to below 140°F.</li> </ul>
<p>BLIND or SHADE will not pair to BRIDGE.</p>	<ul style="list-style-type: none"> <li>• BLIND or SHADE is out of range of BRIDGE. Move BRIDGE closer to BLIND or SHADE.</li> </ul>
<p>Bottom rail is not level.</p>	<ul style="list-style-type: none"> <li>• BLIND or SHADE strings are not evenly tensioned. Move BLIND or SHADE to lower position and then to upper position.</li> </ul>

# Inductive Charging Instructions



Shown is the 12V wall adapter cord, Inductive Charger Transmitter, and suction cup, all included in the charging kit.

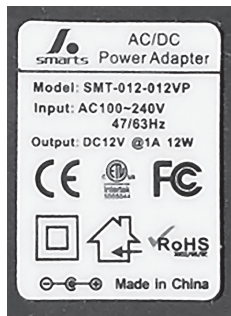

Close up of specifications on the 12V wall adapter



Inductive transmitter paired with receiver located on casement unit, with wire facing interior. If needed the suction cup included can help keep some of the cord weight off of the charger.

## GETTING STARTED

If your Pella Insynctive Motorized Blinds or Shades have been working just fine up until recently and then quit working, they likely need to be charged with the Insynctive Inductive Charger.

NOTE: Ensure you are using the supplied wall adapter with the Inductive Charger to ensure safe and proper operation of the Inductive Charger. Failure to do so could result in injury, damage to product and property, and void any warranty of Insynctive products.

## Locating the Inductive Charger Receiver

On the other end of the inductive charger is the receiver (not visible), located inside the battery pack. In order for the charger to work properly, the transmitter and receiver must be properly aligned.

To find the location of the receiver located inside your Pella Lifestyle Series product, place the transmitter on the glass, along the bottom edge of the unit, with the wire on the transmitter pointing in towards the center of the unit.

- If on the correct side, the transmitter will magnetically connect to the receiver, LED will turn BLUE.
- If the transmitter does not magnetically connect to the receiver, place the transmitter on the other side of the unit.

## Using the Charger

### 1. Connect transmitter with the AC adapter and plug in

- When you plug in the 12V wall adapter to the transmitter, the LED on the transmitter should turn GREEN. This indicates that there is power to the transmitter, and the correct power source is being used.
- If the wrong wall adapter is used, or there is an issue with the power source itself, the LED on the transmitter will blink RED (pattern: Blink, Blink, Stop; Blink, Blink Stop; etc...)
- The transmitter requires a 12VDC power source. Only use the wall adapter provided to you with charger kit purchased from Pella.
- If you are using the provided power source, and still have a blinking RED LED, call Customer Service at 855-473-5524.

### 2. Place transmitter on the window unit

- When the transmitter has been properly placed on the receiver, the LED on the transmitter will turn BLUE. The BLUE LED indicates the inductive charger is charging the battery pack. It will remain blue until the battery is fully charged, at which time it will turn Green (approx. 8 hours for full charge).

### 3. Remove transmitter once charging is complete

# Inductive Charging Instructions (continued)



Green Light - Good

## LED COLOR INDICATORS ON TRANSMITTER

### Green Light - Good

- Indicates the transmitter is properly powered, on.
- Indicates battery charging is complete when attached to receiver.



Blue Light - Good

### Blue Light - Good

- Indicates the receiver and transmitter are properly aligned.
- Indicates inductive charger is currently charging battery.

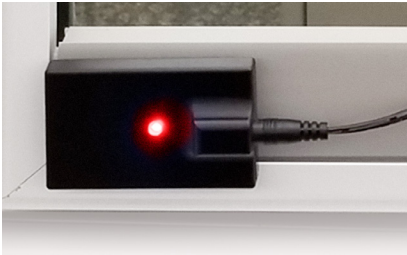

Red Light - Error Code

### Red Light - Error Code

- RED light is an error or warning indicator of 2 possible types:
  - The wrong wall adapter is being used, or there is an issue with the power source itself (Voltage is too high, low)
    - LED will blink RED (pattern: Blink, Blink, Off)
  - The charger is too hot, remove transmitter
    - LED will blink RED (pattern: On, Off)



Yellow Light - Error Code

### Yellow Light - Error Code

- Indicates the transmitter is properly powered, but not optimally aligned with the receiver.
- Readjust the transmitter until the LED turns BLUE.

If you have any questions or issues regarding your Pella Insynctive inductive charging system for motorized blinds and shades, or any other Pella product please reach out to our Customer Service at 855-473-5524.

# FCC Compliance and Industry Canada

---

This equipment has been tested and found to comply with the limits for Class B digital devices, pursuant to Part 15 of the FCC Rules. These limits are designed to provide reasonable protection against harmful interference in a residential installation. This equipment generates, uses and can radiate radio frequency energy and, if not installed and used in accordance with the instruction manual, may cause harmful interference to radio communications. However, there is no guarantee that interference will not occur in a particular installation. If this equipment does cause harmful interference to radio or television reception, which can be determined by turning the equipment off and on, the user is encouraged to try to correct the interference by one or more of the following measures:

- Reorient or relocate the receiving antenna.
- Increase the separation between the equipment and receiver.
- Connect the equipment to an outlet on a different circuit from the receiver.
- Consult the dealer or an experienced radio/TV contractor for help.

Changes or modifications not expressly approved by Pella Corporation could void the user's authority to operate the equipment.

This device complies with Industry Canada license-exempt RSS standard(s). Operation is subject to the following two conditions: (1) this device may not cause interference, and (2) this device must accept any interference, including interference that may cause undesired operation of the device.

Cet appareil est conforme avec Industrie Canada exempts de licence standard RSS. L'opération est soumise aux deux conditions suivantes : (1) cet appareil ne peut causer d'interférences, et (2) cet appareil doit accepter toute interférence, y compris les interférences qui peuvent causer un mauvais fonctionnement de l'appareil.

FCC ID: SO7-206B0000      FCC ID: SO7-209L0000  
IC: 11009A-206B0000      IC: 11009A-209L0000

## Limited Warranty

---

A two-year limited warranty comes standard with purchase. For complete warranty details, visit [Pella.com/Warranty](http://Pella.com/Warranty).

