

NOTES:

1. PROVIDE PAVED SHOULDERS WHEN THE TRAFFIC VOLUME IS GREATER THAN 5,000 AADT.
2. SHOULDER PAVEMENT WILL BE THE SAME AS THE TOP LAYER OF THE ROAD RESURFACING.
3. WHEN SHOULDER IS DESIGNATED OR MARKED AS A BIKE FACILITY PAVED SHOULDER MUST BE SIX (6) FEET WIDE.

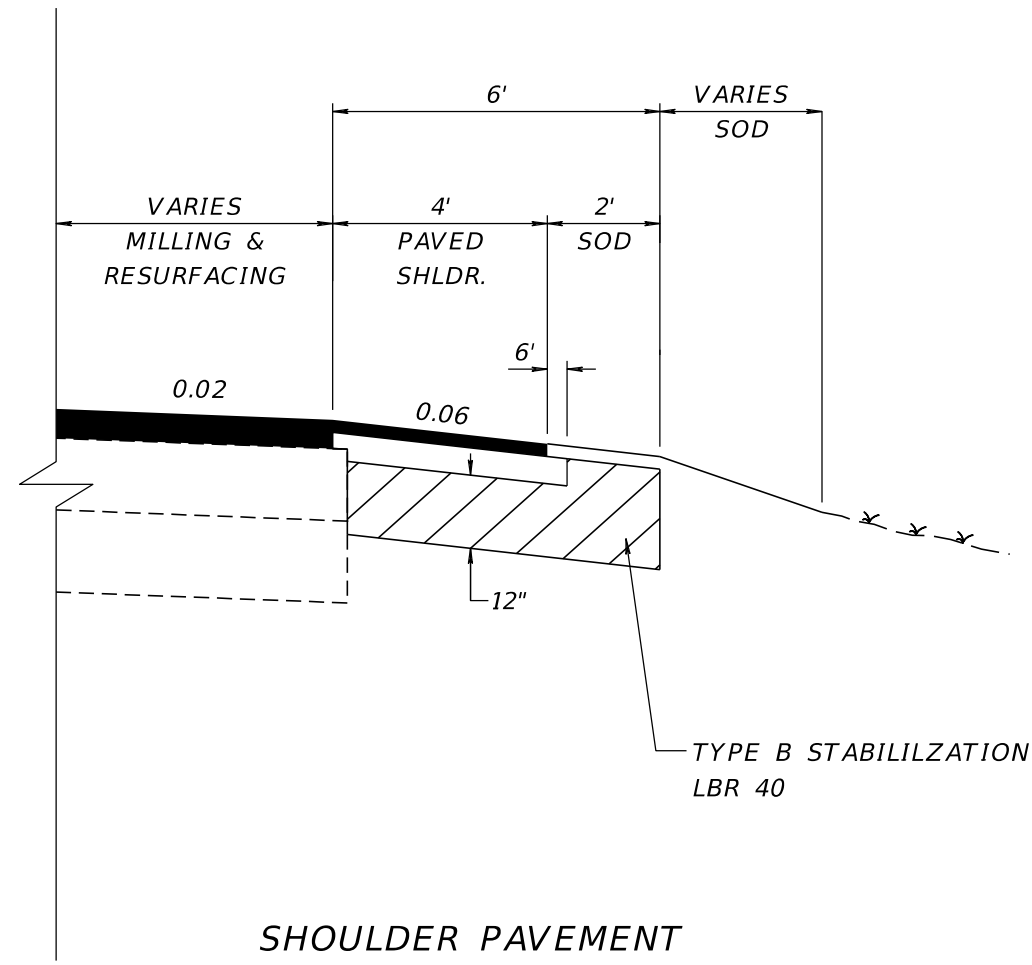

OPTIONAL BASE GROUP 1
FOR ASPHALT PAVEMENT SEE NOTE 2.

PAVED SHOULDER

N.T.S

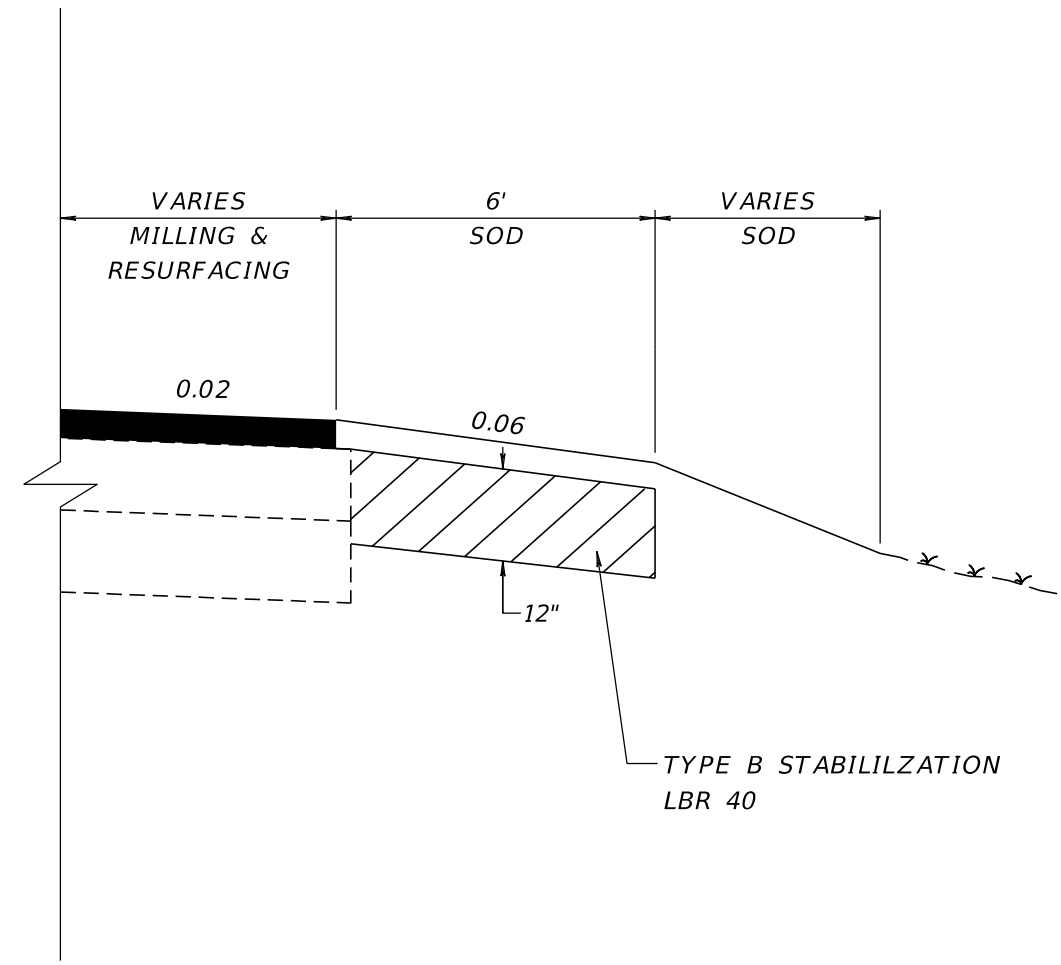

STABILIZED SHOULDER WITH SOD

N.T.S