



KYORUGI COMPETITION RULES & INTERPRETATION

Effective May 25, 2026

Published by USA Taekwondo
May 2026

© 2026 USA Taekwondo
All rights reserved

Table of Contents

Article 1. Purpose	2
Article 2. Application	3
Article 3. Competition Area	4
Article 4. Contestant	9
Article 5. Weight Divisions	13
Article 6. Classification and Methods of Competition	18
Article 7. Duration of Contest	19
Article 8. Drawing of Lots	20
Article 9. Weigh-In	21
Article 10. Procedure of the Contest	23
Article 11. Permitted Techniques and Areas	25
Article 12. Valid Points	26
Article 13. Scoring and Publication	28
Article 14. Prohibited Acts and Penalties	30
Article 15. Golden Points and Decision of Superiority	35
Article 16. Decisions	38
Article 17. Knock Down	40
Article 18. Procedure in the Event of a Knock Down	41
Article 19. Procedures for Suspending the Contest	44
Article 20. Technical Officials	47
Article 21. Instant Video Replay	51
Article 22. Team Competition	55
Article 23. Protest and Arbitration	62
Article 24. Sanction Procedure	65
Article 25. Other Matters Not Specified in the Rules	68
Official Letter of Protest	69

Article 1. Purpose

1. The purpose of the Competition Rules is to provide standardized rules for all levels of championships organized, promoted or sanctioned by USA Taekwondo (USATKD), and ensure that all matters related to USATKD competitions are conducted in a fair and orderly manner.
2. These rules are also intended to standardize Taekwondo competition in the United States in accordance with World Taekwondo (WT)—the international governing body for the sport of Taekwondo. A competition that does not follow the fundamental principles of these rules cannot be recognized as a USA Taekwondo competition.

Article 2. Application

1. These Competition Rules shall apply to all competitions to be promoted and/or organized by USATKD. Any USATKD association that wishes to modify any part of the Competition Rules for a particular competition must first receive the approval of USATKD.
 - 1.1. Any organization wanting to make a change to some portion of the existing rules sanctioned event must submit the contents of the proposed changes to USATKD, along with the reasons for the change. Approval of any changes in these rules must be received from USATKD one month prior to the scheduled competition.
2. All competitions promoted, organized, or sanctioned by USATKD shall abide by the USATKD Medical Code and USATKD Anti-Doping Rules.

Explanation #1

With prior approval from USATKD, competition rules such as ring dimensions, weight categories, the number of referees, positions for the Inspector, Recorder and Medical Staff, etc., and contest duration may be modified for a particular event or events. However, basic competition principles such as valid points, warnings, deductions, and the Contest Area must not be changed. Under no circumstances may head contact be allowed for age and belt groups where it is not permitted under Modified Safety Rules.

Article 3. Competition Area

1. The Competition Area

- 1.1. The Competition Area consists of a Contest Area and a Safety Area. It shall have a flat surface without any obstructing projections, and be covered with an elastic, non-slippery mat.
- 1.2. The Competition Area may also be installed on a platform 0.6m – 1m high, if necessary. For the safety of the contestants, the outer part of the Boundary Line (the Safety Boundary Area) shall be inclined at a gradient of less than 30 degrees.
- 1.3. One of the following shapes can be used for the Contest Area:

1.3.1. Square shape

The square Contest Area shall be 8m x 8m. Surrounding the contest area, approximately equidistant on all sides, shall be the Safety Area. The size of the Competition Area (which includes both the Contest Area and the Safety Area) shall be no smaller than 10m x 10m and no larger than 12m x 12m. If the Competition Area is on a platform, the Safety Area may be increased as needed to ensure the safety of contestants. The Competition Area and the Safety Area shall be of different, contrasting colors.

1.3.2. Octagonal shape

The Competition Area is comprised of a Contest Area and Safety Area. The Competition Area shall be square shaped and the size shall be no smaller than 10m x 10m and no larger than 12m x 12m. At the center of the Competition Area shall be the octagonal Contest Area. The Contest Area shall measure approximately 8m across, and each side of the octagon shall have a length of approximately 3.3m. Between the outer line of the Competition Area and the boundary line of the Contest Area is the Safety Area. The Contest Area and the Safety Area shall be of different, contrasting colors.

1.3.3. Alert Area

The Alert Area is a designated safety buffer zone within the Contest Area, formed by a continuous 60cm-wide band extending inward from the outer edge of the Contest Area toward its center. This applies equally to both octagonal- shaped and square-shaped Contest Areas, following the respective perimeter shape. Its purpose is to visually warn athletes and referees of their proximity to the boundary, enhancing spatial awareness and preventing accidental exits. The Alert Area shall not be marked with lines or tape but must be clearly distinguished from the rest of the Contest Area by using a visibly different color, without affecting the conduct or scoring of matches.

2. Indication of Positions

- 2.1. The outer border of the Contest Area shall be called the Boundary Line and the outer border of the Competition Area shall be called the Outer Line(s).

- 2.2. The front outer line adjacent to the Recorder's Desk shall be called Outer Line #1, and Clockwise from Outer Line #1, the other lines shall be called Outer Lines #2, #3, and #4. The Boundary Line adjacent to the Outer Line #1 shall be called Boundary Line #1 and clockwise from Boundary Line #1, the other lines shall be called Boundary Lines #2, #3, and #4. In case of Octagonal Shape Contest Area, The Boundary Line adjacent to the Outer Line #1 shall be called Boundary Line #1 and clockwise from Boundary Line #1, the other lines shall be called Boundary Lines #2, #3, #4, #5, #6, #7, and #8.
- 2.3. Positions of Referee and Contestants at the beginning and end of the Match: The position of the Contestants shall be at the two opposing points, 1m from the center point of the Contest Area parallel to Outer Line #1. The Referee shall be positioned at a point 1.5m from the center of the Contest Area toward the Outer Line #3.
- 2.4. Positions of Judges: The position of the 1st Judge shall be located at a point in minimum 2 m from the corner of the Boundary Line #2. The position of the 2nd Judge shall be located at a point in minimum 2 m outward from the center of the Boundary Line #5. The position of the 3rd Judge shall be located at a point in minimum 2 m from the corner of the Boundary Line #8. In case of two Judges setting the position of the 1st Judge shall be located at a point in minimum 3 m from the outer line #1 on the left of the mat and the 2nd Judge shall be located at a point in minimum 3m from of the outer line #3 on the right. When only one Judge is used, the Judge may be seated at the Operation Table to perform judging duties. The positions of Judges may be altered to facilitate media, broadcasting and/or sports presentation.
- 2.5. Position of Recorder & IVR: Position of Recorder & IVR shall be located at a point 2 m from the Outer Line #1. Position of Recorder may be altered to accommodate the environment of the venue and requirements from media broadcasting and/or sports presentation.
- 2.6. Positions of Coaches: The position of the Coaches shall be marked at a point in minimum 2 m or more from the center point of the Outer Line of each contestant's side. Position of the coaches may be altered to accommodate the environment of the venue and requirements from media broadcasting and/or sports presentation.
- 2.7. Position of Inspection desk: The position of the Inspection Desk shall be near the entrance of the Competition Area for the inspection of the contestants' protective equipment.

Explanation #1

Elastic mat: The degree of elasticity and slipperiness of the mat must be approved by USATKD before the competition. USATKD-sanctioned tournaments shall not be held on unmatted concrete or hardwood floors.

Explanation #2

Color: The mat's surface must not be overly reflective, or in any way tiring to the contestants' or spectators' vision. The color scheme should also be appropriately matched to the competitors' equipment, uniform and the competition surface.

Explanation #3

Inspection Desk: At the Inspection Desk, the inspector verifies that all the materials worn by the contestant are approved by the WT/USATKD and fit the contestant properly. If any protective equipment is found to be inappropriate or unsafe, the contestant will be asked to change it.

Octagonal mat on platform

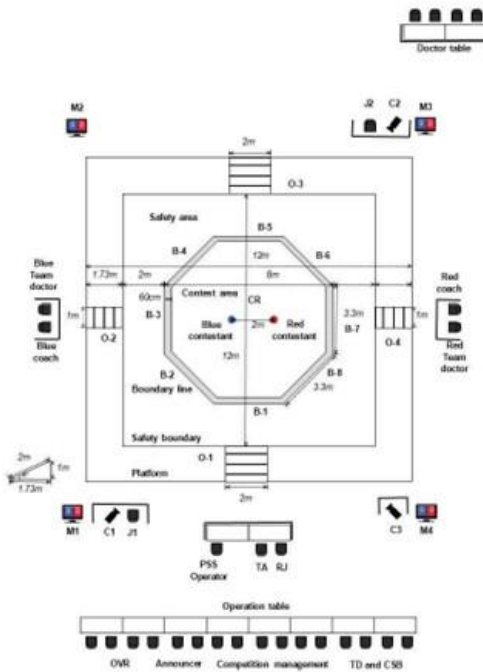

Octagonal mat on floor

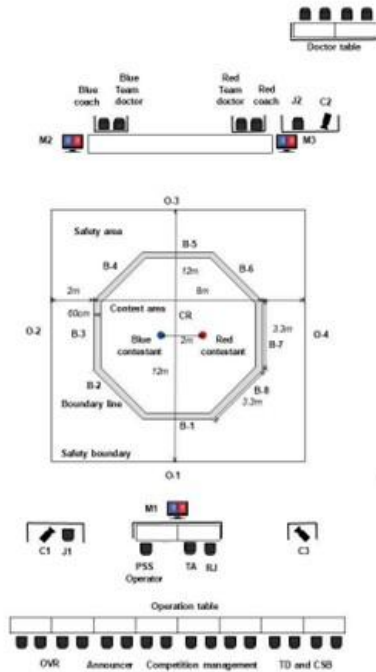

Square mat on platform

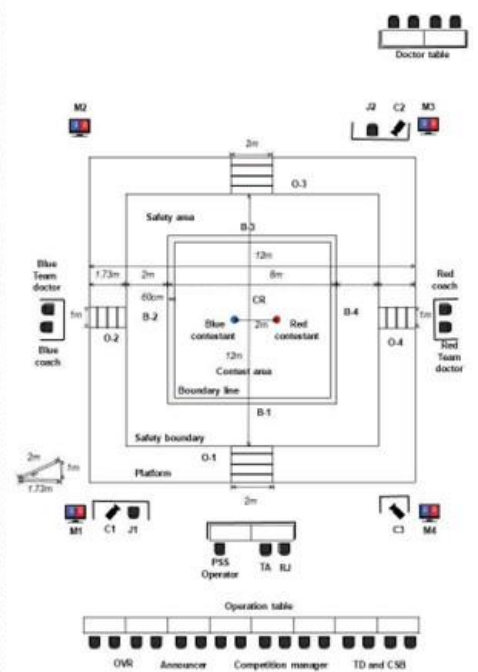

Glossary:

TD: Technical Delegate
 CSB: Competition Supervisory Board
 OVR: On Venue Result

CR: Center Referee
 J1, J2: Corner Judge 1 and 2
 RJ: Review Jury

C1 - C2 - C3 : Camera 1, 2 and 3
 M1 - M2 - M3 : Scoreboard monitor 1, 2, 3 and 4

O-1: Outer line 1
 B-1: Boundary line 1

Octagonal mat on platform

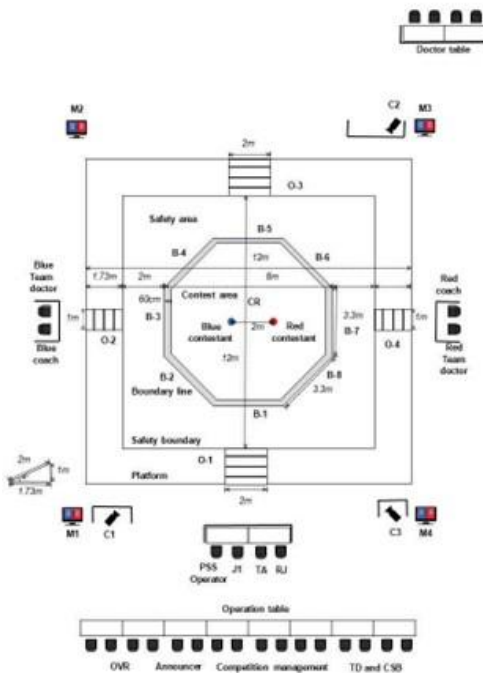

Octagonal mat on floor

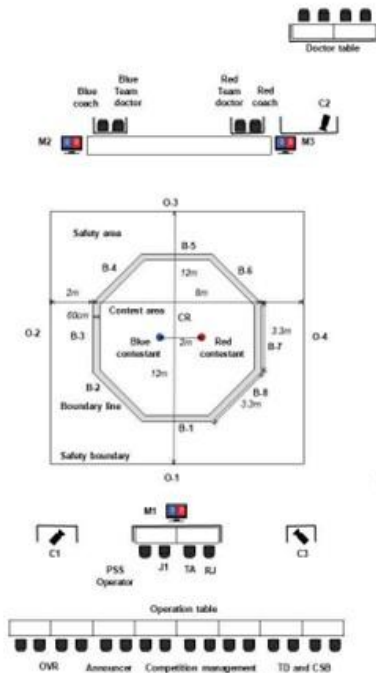

Square mat on platform

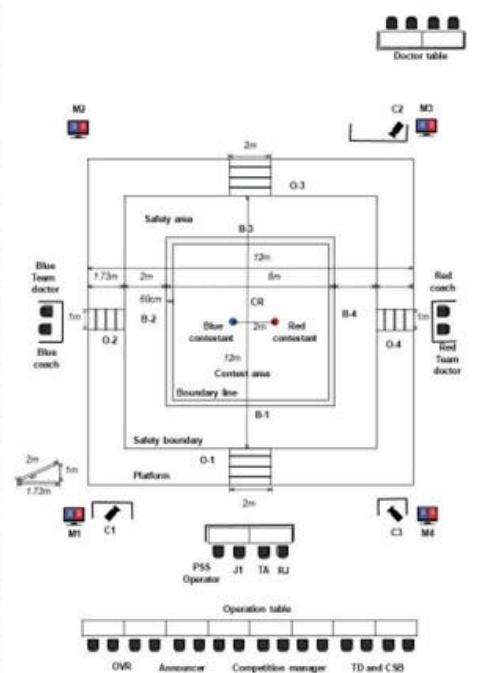

Glossary:

TD: Technical Delegate
 CSB: Competition Supervisory Board
 OVR: On Venue Result

CR: Center Referee
 J1: Corner Judge 1
 RJ: Review Jury

C1 - C2 - C3 : Camera 1, 2 and 3
 M1 - M2 - M3 : Scoreboard monitor 1, 2, 3 and 4

O-1: Outer line 1
 B-1: Boundary line 1

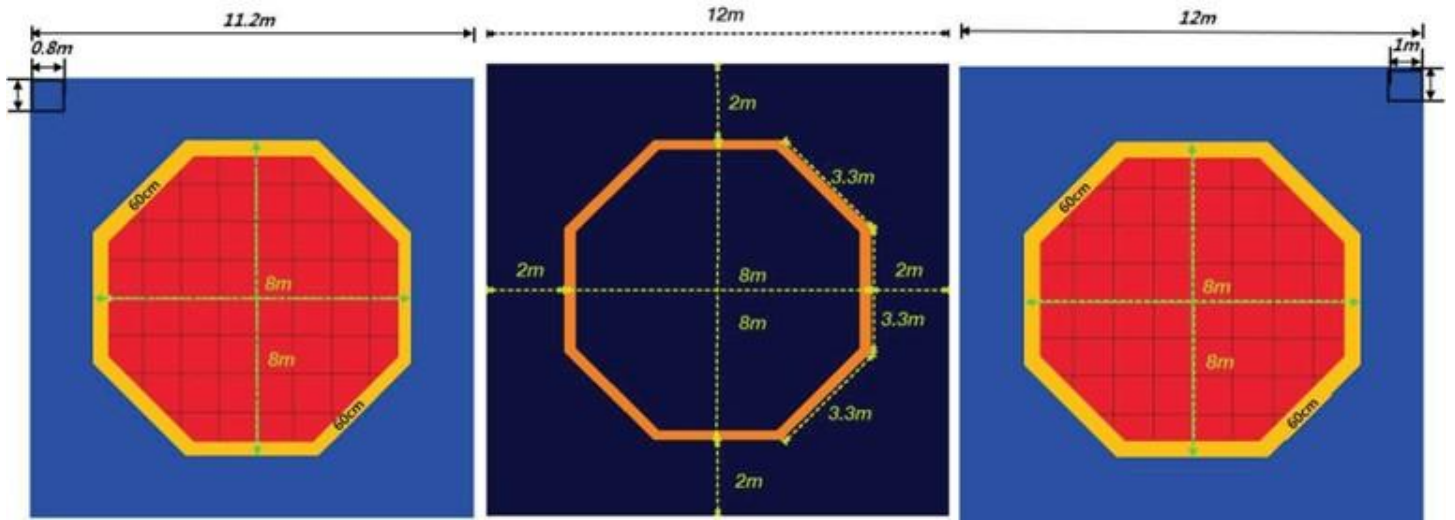

Article 4. Contestant

1. Qualifications USATKD Contestants

- 1.1. Citizen or resident of the United States
- 1.2. World Class Black belt athletes MUST be U.S. citizens. World Class ages are Cadet 12-14, Junior 15-17, Senior 17+.
- 1.3. Age limit: The age limit is based on the year, not on the date.
- 1.4. Currently registered USATKD athlete member
- 1.5. All black belt contestants must submit a copy of their Dan/Poom Certificate, current USATKD identification card, and birth certificate at the time of registration with the Tournament Organizing Committee.
- 1.6. To be eligible for Senior competition, contestants must be at least 17 years old in the year the pertinent tournament is held. Contestants must be between 15-17 years old for Junior Taekwondo Championships, and 12-14 years old for Cadet Championships. (Ages for Youth Olympic Games qualification might be different depending on the decision of the IOC.)
- 1.7. All contestants participating in a tournament are required to observe the Code of Conduct of USATKD and the rules of the tournament. Violators are subject to sanction.
- 1.8. Athlete Protection and Gender Participation Guidelines: In accordance with directives issued by the USOPC, no person who is born as a male shall be permitted to enter any USA Taekwondo event in any category designated as "Female." For purposes of this policy, "male" means a person belonging, at conception, to the sex that produces the small reproductive cell as set out in Executive Order 14168 (January 20, 2025).

2. Proof of citizenship

Proof of Citizenship	Age/Belt Division	Documentation Required
US Passport US Passport Card US Birth Certificate	World Class Black Belt Divisions (Cadet, Junior, Senior)	Proof of Citizenship

3. Contestant Uniform and Competition Equipment

- 3.1. At USATKD-sanctioned competitions, contestants' uniforms and all competition equipment, such as, but not limited to mats, PSS, IVR and protective equipment must be approved by USATKD.

4. Official Uniform (Dobok)

4.1. All contestants must wear a white Taekwondo V-neck USATKD/WT uniform (dobok) in good condition. Black belts must wear black-collared uniforms. Poom rank (14 and under black belts) may wear poom uniforms with black and red collars. Color belts must wear white-collared uniforms; color belts cannot wear black-collared uniforms.

4.1.1. Optional: Athletes may wear black pants.

4.2. No tape will be allowed on any part of the uniform.

5. Protective Equipment

5.1. Contestants shall wear an approved trunk protector, head protector, groin guard (mandatory for both male and female competitors), gloves (see below), forearm protector, shin protectors, instep protectors or sensing socks (if using an electronic Protector and Scoring System) and a mouthguard before entering the Contest Area. The head protector must be firmly tucked under the left arm when entering the Contest Area and shall be put on the head after bowing to the opponent before the start of the contest.

5.2. The groin, forearm, and shin protectors must be worn inside the Taekwondo uniform. Wearing of any other items on the head other than head protector shall not be permitted, except for religious reasons. A previously approved religious item shall be worn beneath the head protector and inside the dobok and shall not cause harm or obstruct the opposing contestant.

6. Personal Requirements

6.1. All competitors shall keep their nails cut short, clear or nude nail polish only, and shall not wear any articles that may injure or endanger an opponent. Any competitor whose hair, in the opinion of the referee, is so long as to risk causing inconvenience to other competitors or interfere with the PSS system, shall be required to tie it back securely. Long hair must be tucked inside the headgear.

7. Metallic Articles

7.1. Contestants are not allowed to wear any kind of metallic articles or hard objects, such as rings, eyeglasses (including prescribed safety or sport eyeglasses or eye goggles), necklaces, watches, bracelets, earrings, hair clips, etc.

8. Personal Hygiene

8.1. All competitors must maintain the highest standard of personal hygiene, keep their nails cut short, and groom their hair neatly.

9. Taping

- 9.1. Taping on the foot and hand shall be allowed for the protection of athletes. For an injury, the minimum amount of tape that will protect the area should be used. Taping of feet and hands will be strictly checked during the athlete inspection process. A stamp from the Tournament Medical Staff is required on all tape. If there is a question, the inspector or referee should have the wrapping examined and approved by the Tournament Medical Staff. Under no circumstances will a hard splint or cast be allowed.
- 9.2. Any taping must be removed during general weigh-in to ensure that there is no open wound, cut, or bleeding.
- 9.3. There will be no taping beneath the sensor socks unless it is approved by the USATKD Medical Staff because of injury.

10. Any violators of this article will be required to correct the violation within one minute, or face disqualification.

11. Medical Control

- 11.1. At Taekwondo events promoted or sanctioned by USATKD, any use or administration of drugs or chemical substances described in the U.S. Olympic Committee anti-doping by-laws is prohibited. International Olympic Committee doping by-laws shall be applied to Taekwondo competition in the Olympic Games and other multi-sport Games.
- 11.2. USATKD may carry out any doping testing deemed necessary to ascertain if a contestant has committed a breach of this rule. Any winner who refuses to undergo this testing or who proves to have committed such a breach shall be removed from the final standings, and the record shall be transferred to the contestant next in line in the competition standings.
- 11.3. The organizing committee shall be responsible for making arrangements to carry out medical testing.

Explanation: USATKD Equipment Standards

Belt Colors: Only WT/USATKD belt colors will be allowed—black, poom (black and red), red, blue, green, yellow). Belts with stripes will be allowed.

Gloves: World Class Cadet Black Belts (12-14), Junior Black Belts (15-17) and Senior Black Belts are required to wear USATKD/WT-approved Taekwondo gloves. Gloves may be red, blue, or white. If the competitor chooses to wear red or blue gloves, they must correspond with the color of the chest protector. Gloves must be open finger style.

For all other divisions, gloves are optional and must comply with the above rule. Cloth gloves or hand covers are not allowed.

Properly fitting head protector: Unless electronic PSS head protectors are used, all participants must provide their head protector with no markings other than corporate logos. World Class Cadet Black Belts (12-14), Junior Black Belts (15-17) and Senior Black Belts are required to wear red or blue head protectors, corresponding with the color of the chest protector. White head protectors may be used. Cracks or defects in the headgear will not be allowed.

Mouthguard: All athletes are required to use a mouthguard, with a minimum thickness of 3mm. Mouthguards must be clear or white only. Athletes with dental braces must wear special mouthguards for braces that cover all of the braces (double braces for top and bottom braces.)

Groin guard: All athletes (male and female) are required to wear a groin guard, which must be worn inside the pants during competition.

Properly fitting chest protector: Where an electronic Protection and Scoring System (PSS) is being used, all athletes will be provided a red and blue full-body WT trunk protector. Both players must use the same size PSS.

When an electronic Protection and Scoring Systems (PSS) is not being used, all athletes must provide their own red and blue full-body WT-approved trunk protector. The trunk protector must cover the entire valid scoring area, from the armpit to the hip bone. All trunk protectors must wrap around and cover the back of the athlete in the valid scoring area.

Shin and instep protection: Shin and instep protectors are required, and they must be made of foam, cloth or vinyl. PSS sensor socks with built-in instep padding are also allowed. The instep protector may be red, blue, or white, but must correspond with the color of the chest protector. If choosing to wear blue or red protectors; any color shin protector is allowed. Cloth or foam knee pads are permitted.

Forearm guard: Forearm guards are required and they must be made of foam, cloth or vinyl. Any color forearm guard will be allowed. Cloth or foam elbow pads are permitted.

Please Note: USATKD reserves the right to disallow any uniform or equipment if it is found to be unsafe, offensive or degrading

Article 5. Weight Divisions

1. Contestants divisions are divided into men's and women's divisions.
2. Weight divisions for USATKD Seniors are classified as follows:

2.1. World Weight Categories

Men's Divisions		Women's Divisions	
Under 54kg	Not exceeding 54 kg	Under 46kg	Not exceeding 46 kg
Under 58kg	Over 54 kg & not exceeding 58 kg	Under 49kg	Over 46 kg & not exceeding 49 kg
Under 63kg	Over 58 kg & not exceeding 63 kg	Under 53kg	Over 49 kg & not exceeding 53 kg
Under 68kg	Over 63 kg & not exceeding 68 kg	Under 57kg	Over 53 kg & not exceeding 57 kg
Under 74kg	Over 68 kg & not exceeding 74 kg	Under 62jg	Over 57 kg & not exceeding 62 kg
Under 80kg	Over 74 kg & not exceeding 80 kg	Under 67kg	Over 62 kg & not exceeding 67 kg
Under 87kg	Over 80 kg & not exceeding 87 kg	Under 73kg	Over 67 kg & not exceeding 73 kg
Over 87kg	Over 87 kg	Over 73kg	Over 73 kg

2.2. Olympic (6) Weight Categories

Men's Divisions		Women's Divisions	
Under 54kg	Not exceeding 54kg	Under 46kg	Not exceeding 46 kg
Under 60kg	Over 54 kg & Not exceeding 60 kg	Under 51kg	Over 46 kg & Not exceeding 51 kg
Under 67kg	Over 60 kg & Not exceeding 67 kg	Under 57kg	Over 51 kg & Not exceeding 57 kg
Under 74kg	Over 67 kg & Not exceeding 74 kg	Under 63kg	Over 57 kg & Not exceeding 63 kg
Under 82kg	Over 74 kg & Not exceeding 82 kg	Under 70kg	Over 63 kg & Not exceeding 70 kg
Over 82kg	Over 82 kg	Over 70kg	Over 70 kg

2.3. Olympic (4) Weight Categories

Men's Divisions		Women's Divisions	
Under 58kg	Not exceeding 58 kg	Under 49kg	Not exceeding 49 kg
Under 68kg	Over 58 kg & not exceeding 68 kg	Under 57kg	Over 49 kg & not exceeding 57 kg
Under 80kg	Over 68 kg & not exceeding 80 kg	Under 67kg	Over 57 kg & not exceeding 67 kg
Over 80kg	Over 80 kg	Over 67kg	Over 67 kg

2.4. Aspiring Color Belt Weight Categories

Men's Divisions		Women's Divisions	
Under 58kg	Not exceeding 58 kg	Under 49kg	Not exceeding 49 kg
Under 68kg	Over 58 kg & not exceeding 68 kg	Under 57kg	Over 49 kg & not exceeding 57 kg
Under 80kg	Over 68 kg & not exceeding 80 kg	Under 67kg	Over 57 kg & not exceeding 67 kg
Over 80kg	Over 80 kg	Over 67kg	Over 67 kg

3. Weight divisions for USATKD Juniors are classified as follows:

3.1. World Weight Categories

	Men's Divisions		Women's Divisions
Under 45kg	Not exceeding 45 kg	Under 42kg	Not exceeding 42 kg
Under 48kg	Over 45 kg not exceeding 48 kg	Under 44kg	Over 42 kg not exceeding 44 kg
Under 51kg	Over 48 kg not exceeding 51 kg	Under 46kg	Over 44 kg not exceeding 46 kg
Under 55kg	Over 51 kg not exceeding 55 kg	Under 49kg	Over 46 kg not exceeding 49 kg
Under 59kg	Over 55 kg not exceeding 59 kg	Under 52kg	Over 49 kg not exceeding 52 kg
Under 63kg	Over 59 kg not exceeding 63 kg	Under 55kg	Over 52 kg not exceeding 55 kg
Under 68kg	Over 63 kg not exceeding 68 kg	Under 59kg	Over 55 kg not exceeding 59 kg
Under 73kg	Over 68 kg not exceeding 73 kg	Under 63kg	Over 59 kg not exceeding 63 kg
Under 78kg	Over 73 kg not exceeding 78 kg	Under 68kg	Over 63 kg not exceeding 68 kg
Over 78kg	Over 78 kg	Over 68kg	Over 68 kg

3.2. Aspiring Color Belt Weight Categories

Men's Divisions		Women's Divisions	
Under 48kg	Not exceeding 48 kg	Under 44kg	Not exceeding 44 kg
Under 55kg	Over 48 kg & not exceeding 55 kg	Under 49kg	Over 44 kg & not exceeding 49 kg
Under 63kg	Over 55 kg & not exceeding 63 kg	Under 55kg	Over 49 kg & not exceeding 55 kg
Under 73kg	Over 63 kg & not exceeding 73 kg	Under 63kg	Over 55 kg & not exceeding 63 kg
Over 73kg	Over 73 kg	Over 63kg	Over 63 kg

4. Weight divisions for USATKD Cadets are classified as follows:

4.1. World Weight Categories

Men's Divisions		Women's Divisions	
Under 33kg	Not exceeding 33 kg	Under 29kg	Not exceeding 29 kg
Under 37kg	Over 33 kg & not exceeding 37kg	Under 33kg	Over 29 kg & not exceeding 33 kg
Under 41kg	Over 37 kg & not exceeding 41 kg	Under 37kg	Over 33 kg & not exceeding 37 kg
Under 45kg	Over 41 kg & not exceeding 45 kg	Under 41kg	Over 37 kg & not exceeding 41 kg
Under 49kg	Over 45 kg & not exceeding 49 kg	Under 44kg	Over 41 kg & not exceeding 44 kg
Under 53kg	Over 49 kg & not exceeding 53kg	Under 47kg	Over 44 kg & not exceeding 47 kg
Under 57kg	Over 53 kg & not exceeding 57 kg	Under 51kg	Over 47 kg & not exceeding 51 kg
Under 61kg	Over 57 kg & not exceeding 61kg	Under 55kg	Over 51 kg & not exceeding 55 kg
Under 65kg	Over 61 kg & not exceeding 65 kg	Under 59kg	Over 55 kg & not exceeding 59 kg
Over 65kg	Over 65 kg	Over 59kg	Over 59 kg

4.2. Aspiring Color Belt Weight Categories

Men's Divisions		Women's Divisions	
Under 37kg	Not exceeding 37kg	Under 33kg	Not exceeding 33 kg
Under 45kg	Over 37 kg & not exceeding 45 kg	Under 37kg	Over 33 kg & not exceeding 37 kg
Under 49kg	Over 45 kg & not exceeding 49 kg	Under 44kg	Over 37 kg & not exceeding 44 kg
Under 57kg	Over 49 kg & not exceeding 57 kg	Under 51kg	Over 44 kg & not exceeding 51 kg
Under 65kg	Over 57 kg & not exceeding 65 kg	Under 59kg	Over 51 kg & not exceeding 59 kg
Over 65kg	Over 65 kg	Over 59kg	Over 59 kg

5. Cadet height categories are classified as follows:

Men's Divisions				Women's Division			
Contestants' Height		MAX Weight	MIN Weight	Contestants' Height		MAX Weight	MIN Weight
Under 148cm	Not exceeding 148cm	45kg	33kg	Under 144cm	Not exceeding 144cm	43kg	32kg
Under 152cm	Over 148cm & not exceeding 152cm	48kg	35kg	Under 148cm	Over 144cm & not exceeding 148cm	45kg	33kg
Under 156cm	Over 152cm & not exceeding 156cm	51kg	37kg	Under 152cm	Over 148cm & not exceeding 152cm	48kg	35kg
Under 160cm	Over 156cm & not exceeding 160cm	53kg	39kg	Under 156cm	Over 152cm & not exceeding 156cm	51kg	37kg
Under 164cm	Over 160cm & not exceeding 164cm	56kg	41kg	Under 160cm	Over 156cm & not exceeding 160cm	53kg	39kg
Under 168cm	Over 164cm & not exceeding 168cm	59kg	43kg	Under 164cm	Over 160cm & not exceeding 164cm	56kg	41kg
Under 172cm	Over 168cm & not exceeding 172cm	61kg	45kg	Under 168cm	Over 164cm & not exceeding 168cm	59kg	43kg
Under 176cm	Over 172cm & not exceeding 176cm	64kg	47kg	Under 172cm	Over 168cm & not exceeding 172cm	61kg	45kg
Under 180cm	Over 176cm & not exceeding 180cm	67kg	49kg	Under 176cm	Over 172cm & not exceeding 176cm	64kg	47kg
Over 180cm	Over 180cm	80kg	52kg	Over 176cm	Over 176cm	75kg	50kg

6. Weight divisions for the Aspiring Youth Divisions are classified as follows:

Men's Divisions		Women's Divisions	
Under 30kg	Not exceeding 30 kg	Under 30kg	Not exceeding 30 kg
Under 35kg	Over 30 kg & not exceeding 35 kg	Under 35kg	Over 30 kg & not exceeding 35 kg
Under 40kg	Over 35 kg & not exceeding 40 kg	Under 40kg	Over 35 kg & not exceeding 40 kg
Over 40kg	Over 40 kg	Over 40kg	Over 40 kg

7. Weight divisions for the Aspiring Tiger Divisions (8-9 yrs) are classified as follows:

Men's Divisions		Women's Divisions	
Under 24kg	Not exceeding 24kg	Under 24kg	Not exceeding 24kg
Under 28kg	Over 24kg & not exceeding 28kg	Under 28kg	Over 24kg & not exceeding 28kg
Under 33kg	Over 28kg & not exceeding 33kg	Under 33kg	Over 28kg & not exceeding 33kg
Over 33kg	Over 33kg	Over 33kg	Over 33kg

8. Weight divisions for the Aspiring Dragon Divisions (6-7 yrs) are classified as follows:

Men's Divisions		Women's Divisions	
Under 22kg	Not exceeding 22kg	Under 22kg	Not exceeding 22kg
Under 25kg	Over 22kg & not exceeding 25kg	Under 25kg	Over 22kg & not exceeding 25kg
Over 25kg	Over 25kg	Over 25kg	Over 25kg

9. Weight divisions for the Aspiring Ultra Divisions (33-45 yrs & 46+ yrs) are classified as follows:

Men's Divisions		Women's Divisions	
Under 58kg	Not exceeding 58 kg	Under 49kg	Not exceeding 49 kg
Under 68kg	Over 58 kg & not exceeding 68 kg	Under 57kg	Over 49 kg & not exceeding 57 kg
Under 80kg	Over 68 kg & not exceeding 80 kg	Under 67kg	Over 57 kg & not exceeding 67 kg
Over 80kg	Over 80 kg	Over 67kg	Over 67 kg

10. Team Weight ranges are classified as follows.

Division	Male Team	Female Team	Mixed Gender Team
Maximum number of Athletes	4	4	Maximum 2 male & 2 female
Total Weight Range	300kg or less	260kg or less	2 female athletes: 135kg or less
			2 male athletes: 160kg or less

* Substitute athlete(s) shall participate in the weigh-in.

** If the existing athlete(s) is replaced by substitute athlete(s), the total weight of four athletes including the substitute athlete(s), excluding the replaced existing athlete(s), shall be recalculated and applied.

11. Belt Divisions are as follows: Yellow, Green, Blue, Red, Black

Explanation:

Not exceeding: The weight limit is defined by the criterion of one decimal place away from the stated limit. For example, "not exceeding 50 kg" goes up to 50.0 kg, with 50.1 kg being over the limit, resulting in disqualification.

Over: Over 50.00 kg mark occurs at the 50.1 kg reading; 50.0 kg and below is regarded as insufficient, resulting in disqualification.

Article 6. Classification and Methods of Competition

1. Competitions are divided as follows:
 - 1.1. Individual competition
 - 1.1.1. Individual competition shall normally be between contestants in the same weight class. When necessary, adjoining weight classes may be combined to create a single classification. No contestant can participate in more than one weight category in one event.
2. Systems of competition are divided as follows:
 - 2.1. Single elimination tournament
 - 2.2. Round robin
 - 2.3. Double elimination tournament
3. USATKD-Sanctioned Competitions
 - 3.1. All competition shall be divided into male and female divisions. Non-Black Belt Competition may be subdivided by weight, belt rank, or age with further subdivisions of advanced, intermediate, and beginners.

Explanation:

Consolidated weight divisions: This consolidation method shall follow Olympic weight divisions.

Interpretation: In the tournament system, competition is founded on an individual basis. However, the team standings can also be determined by the sum of the individual standings according to the overall scoring method.

Article 7. Duration of Contest

1. Duration of Contest is classified as follows.
 - 1.1. The duration of the contest shall be three rounds of two minutes each with a one-minute rest period between rounds for World Class Seniors.
 - 1.2. World Class Junior & Cadets rounds 1 minute 30 seconds with a 30 second rest period between rounds.
 - 1.3. All Color Belts, Youth, Dragon, Tiger, and Ultra rounds are one minute with a 30 second rest period between rounds.
2. USATKD, at its discretion, may modify the number of rounds, round duration, and rest periods for specific competitions; for example, 1-minute x 3 rounds, 1 minute 30 seconds x 3 rounds, 2 minutes x 2 rounds, or 5 minutes x 1 round (with one time out of 30 seconds to each competitor).

Article 8. Drawing of Lots

1. The date and time of the drawing of lots shall be set forth in the outline of the championships. At the end of the designated registration date, the Organizing Committee shall publicly announce the list of registered contestants in each weight category. Participants are responsible for confirming their entries before the drawing of lots.
2. The drawing of lots may be conducted by random computerized drawing or by random manual drawing. The method and order of drawing shall be determined by the Organizing Committee.
3. A certain number of contestants may be seeded based on [USATKD Ranking](#). The number of contestants seeded shall be set forth in the outline of the championships.

Article 9. Weigh-In

1. A competitor's weight shall be measured on the day prior to the competition. The weigh-in hours may be extended or shortened, if necessary, with prior approval by USATKD.
2. A competitor's weight may be measured only twice. If a contestant does not qualify the first time, one more official weigh-in is granted within the time limit. So as not to be disqualified during official weigh-in, scales identical to the official one shall be provided at the contestants' place of accommodation or at the arena for pre-weigh-in.
3. During the weigh-in, the contestant is required to show an ID based on the following:
 - 3.1. 12 years and older: Passport, Drivers License, Birth Certificate, Social Security Card, GAL, or School ID
 - 3.2. 11 years and younger: Passport, Birth Certificate, Social Security Card, GAL, School ID, School Report Card, or School Portal
4. For contestants 17 years old and under (male and female, color belts and black belts), weigh in shall be done in athletic clothing. No midriff may be showing. Under no circumstances may a contestant under the age of 18 weigh-in in underwear, or in the nude, in the United States. There is a weigh-in allowance of 0.2 kilograms to compensate for this requirement.
5. For contestants 18 years old and older, weigh-in shall be done in athletic clothing. However, if a contestant wishes, weigh-in may be done in underwear for male and underwear and bra for female contestants. Under no circumstances may a contestant weigh-in in the nude in the United States. There is a weigh-in allowance of 0.1 kilograms to compensate for this requirement.
6. Any irregular action by the competitor, coach or parent during the weigh-in may result in disqualification from tournament participation.
7. Random weigh-ins on the day of the competition
 - 7.1. At the discretion of the Events Director and Tournament Organizing Committee, random weigh-in procedures may be implemented for certain USATKD events and will be announced prior to the competition in the event's information package.
 - 7.2. The random weigh-in will take place at the venue on the morning of the competition and must be completed at least 30 minutes before the start of competition each day. All competitors who pass general weigh-in must be present for random weigh-in a maximum of two (2) hours before the start of the competition; should a competitor fail to appear for the random weigh-in, he/she will be disqualified. The rate of selection for the random weigh-in (typically, 5% of all the day's competitors) will be announced in the information package for the event.
 - 7.3. A maximum weight gain of 5% over the weight category is permitted. A no show, or a competitor who is over the 5% limit will be disqualified. Only one weigh-in attempt will be allowed for the random weigh-in.

Explanation:

Prior to the competition: Contestants listed to compete on a scheduled day will be weighed in on the day before. The time for weigh-in will be decided by the Organizing Committee and communicated to the participants in the event information packet.

Separate weigh-in for males and females: Male and female contestants will have separate sites for weigh-ins. The gender of weigh-in officials shall be the same as that of the contestants.

Disqualification during official weigh-in: If a competitor is disqualified at the official weigh-in, the competitor will not receive a participation point. If a contestant attempts to cheat the process of weigh-in, the contestant shall be disqualified by decision of the event Referee Chairman in consultation with the weigh-in official.

Scales: The practice scale(s) must be of the same type and calibration as that of the official scale and this must be verified prior to the competition by the Organizing Committee.

Article 10. Procedure of the Contest

1. Call for Contestants
 - 1.1. The name of the contestants shall be announced at the Athlete Calling Desk three (3) times beginning thirty (30) minutes prior to the scheduled start of the contest. If a contestant fails to report to the Desk following the third call, the contestant shall be disqualified, and this shall be announced.
2. Inspection of body, uniform and protective equipment
 - 2.1. After being called, the contestants shall undergo inspection of body, uniform and protective equipment at the inspection desk by the inspectors assigned by the USATKD Referee Chairman or USATKD designee for that event. If the inspection desk is not used, the referee shall inspect the contestants at the court prior to the start of the contest.
3. Entering the Competition Area
 - 3.1. After inspection, the contestant and one certified coach shall proceed to the Coach's Area. One accredited doctor or physiotherapist may also accompany the player.
4. Procedure before the beginning and after the end of the contest
 - 4.1. Before the start of the contest, the center referee will command "Chung, Hong." Both contestants will enter the Contest Area with their head protectors firmly tucked under their left arms. When a contestant is not present or is present without being fully attired, including all protective equipment, uniform, etc., at the Coach's Area at the time the referee calls "Chung, Hong," he/she shall be regarded as withdrawn from the contest and the referee shall declare the opponent the winner.
 - 4.2. The contestants shall face each other and make a standing bow at the referee's command of "Cha-ryeot" (attention) and "Kyeong-rye" (bow). A standing bow shall be made from the natural standing posture of "Cha-ryeot" by bending the waist at an angle of more than 30 degrees with the head inclined to an angle of more than 45 degrees. After the bow, the contestants shall put on their head protectors.
 - 4.3. The referee shall start the contest by commanding "Joon-bi" (ready), and "Shi-jak" (start).
 - 4.4. The contest in each round shall begin with the declaration of "Shi-jak" (start) by the referee.
 - 4.5. The contest in each round shall end with the declaration of "Keu-man" (stop) by the referee. Even if the referee has not declared "Keu-man," the contest shall be deemed to have ended when the match clock expired. However, "Gam-jeom" can be given for certain actions even after the expiration of the match clock.

- 4.6. The referee may pause a contest by declaring “Kal-yeo” (break) and resume the contest by the command of “Kye-sok” (continue). When the referee declares “Kal-yeo” the recorder should immediately stop the match time. When the referee declares “Kye-sok,” the recorder should immediately restart the match time.
- 4.7. At the conclusion of the final round, the referee shall once again call “Chung, Hong.” Both contestants shall stand in the same posture as at the beginning of the contest, facing each other. At the referee’s command of “Charyeot (attention)” and “Kyeong-rye (bow),” the contestants shall make a standing bow in the same manner as before. Immediately after the bow, the referee shall declare the winner by raising his/her hand to the winner’s side.
- 4.8. After the referee has declared the winner, both contestants shall leave the contest area.

5. Contest Procedure in Team Competition

- 5.1. Both teams shall stand facing each other in line in submitted team order towards the 1st Boundary Line from the Contestants’ Marks.
- 5.2. Procedure before the beginning and after the end of the contest shall be conducted as in Item 4 of this Article.
- 5.3. Both teams shall leave the Contest Area and stand by at the designated area for each contestant’s match.
- 5.4. Both teams shall line up in the Contest Area immediately after the end of the final match facing each other.
- 5.5. The referee shall declare the winning team by raising his/her own hand to the winning team’s side.

Explanation:

Accredited doctors: When team officials register for the event, copies of relevant licenses of the doctor or physiotherapist (in English) shall be attached. After verification, credentials shall be issued to them. Only medical staff with proper credentials will be allowed to proceed to the Competition Area with the coach and player.

Guideline for Officiating

When using PSS, the referee shall check if the PSS system and sensing socks and gloves worn by both athletes are properly working by having the competitors each perform a single test kick.

Article 11. Permitted Techniques and Areas

1. Permitted techniques

- 1.1. Fist technique: A straight punching technique using the knuckle part of a tightly clenched fist
- 1.2. Foot technique: Delivering techniques using any part of the foot below the ankle bone

2. Permitted areas

- 2.1. Trunk: Attack by fist and foot techniques on the areas covered by the trunk protector are permitted. However, such attacks shall not be made on the part of the spine.
- 2.2. Head: The area above the collar bone. Only foot techniques are permitted.

Article 12. Valid Points

1. Scoring Areas:
 - 1.1. Trunk: The blue or red colored area of the trunk protector
 - 1.2. Head: The entire head above the bottom line of the head protector
2. Criteria for valid point(s):
 - 2.1. Point(s) shall be awarded when a permitted technique is delivered to the scoring areas of the trunk with a proper level of impact.
 - 2.2. Point(s) shall be awarded when a permitted technique is delivered to the scoring areas of the head with a proper level of impact.
 - 2.3. If PSS is used, determination of the validity of the technique, level of impact, and/or valid contact to the scoring area shall be made by the electronic scoring system except fist techniques. These PSS determinations shall not be subject to Instant Video Replay. However, when a kick is delivered to the opponent's head and no points are awarded, only the Center Referee may request an Instant Video Replay in accordance with Article 21.4.3
 - 2.4. Based on guidance from the WT Technical Committee, the USATKD Organizing Committee will determine the required level of impact and sensitivity of the PSS, using different scales in consideration of weight category, gender, and age groups. In certain circumstances as deemed necessary, the Organizing Committee may recalibrate the valid level of impact.
3. The valid points are as follows:
 - 3.1. One (1) point for a valid punch to trunk protector
 - 3.2. Two (2) points for a valid kick to the trunk protector
 - 3.3. Three (3) points for a valid kick to the head
 - 3.4. When a valid turning kick is delivered to the trunk protector or the head, the awarded points shall be doubled: four (4) points for a valid turning kick to the trunk protector, and six (6) points for a valid turning kick to the head.
 - 3.5. One (1) point awarded for every Gam-jeom given to the opposing contestant
 - 3.5.1. For a "Gam-jeom" given due to passive behavior in the last ten (10) seconds of each round, one (1) "Gam-jeom" shall be recorded and two (2) points shall be awarded to the opponent. Passive behavior includes:
 - 3.5.1.1. Crossing the boundary line

3.5.1.2. Falling down

3.5.1.3. Running away from the opponent or avoiding

4. Match score:

4.1. Match score shall be the sum of points of the three rounds.

4.2. In the best of three (3) system, match score shall be the sum of the number of rounds won of the three rounds.

5. Invalidation of point(s): When a contestant records points following prohibited act(s)

5.1. If the prohibited act is followed by point(s), the referee shall declare the penalty for the prohibited act and invalidate the point(s).

Explanation:

Back kick (Dwichagi) is one type of turning kick technique, the head and shoulder rotation must occur to be considered as a back kick (Dwichagi) and awarded technical points.

When contestants kick opponent by the back kick (Dwichagi), without contestant's simultaneous rotation of head and shoulder, 'Back kick' (Dwichagi) will not be considered turning kick

Article 13. Scoring and Publication

1. Call of valid point(s) shall be determined primarily using the electronic scoring system installed in Protector and Scoring Systems (PSS). For punch points, a semi-automatic scoring method may be applied, where the PSS measures the power of impact and judges determine the accuracy to award points using manual scoring devices. For body and head points, when scoring is recognized by the PSS, additional points awarded for turning kicks shall be scored by judges using manual scoring devices. If PSS is not used, including points for techniques to the body, head and punch areas where PSS is not applied, all scoring shall be determined by judges using manual scoring devices.
2. Where applicable, sensing gloves may be used. When sensing gloves are employed, the impact of the punch shall be detected by the PSS, and the technique shall be validated by corner judges. Only punches that meet both conditions shall be awarded points.
3. If PSS for the head is not used, scoring for all kicking techniques to the head shall be made by judges using the manual scoring devices.
4. The additional points given for a turning kick shall be invalidated if the turning kick was not scored as a valid point(s) by PSS.
5. Under a three (3) corner judge system, two or more judges shall be needed to confirm valid scoring.
6. Under a two (2) corner judge system, two judges shall be needed to confirm valid scoring.
7. Where body and head scoring are operated through their respective Protector and Scoring Systems (PSS), and punch scoring is operated through sensing gloves, the match may be conducted with one (1) Corner Judge, who shall determine the validity and accuracy of all technical actions and award points accordingly.

Guidelines for Officiating

Protector and Scoring System: Any PSS used at a USATKD-sanctioned event must meet all USATKD and WT requirements for the enhancement of competition and insurance of fair match outcome.

Valid turning kicks: In the case of using PSS, double points will be validated by the PSS if the transmitter acknowledges the strike, and the technical judge confirms a “valid turn.” Judges must press to award the additional points for a “valid turn.” Judges should press for all valid turning kicks without reference to accuracy or power, and without looking at the monitor to determine if the point scored. In the event that the transmitter does not acknowledge the kick, no point shall be given, regardless of the judges’ scoring of a “valid turn.”

Use of trunk protectors not equipped with electronic sensors: All scoring must be done according to the judge’s own determination of accuracy and power, and there must be equipment available capable of immediately conveying the recorded point to the scoreboard.

Valid turning kick to the head or body: Where electronic headgear is not used, judges must first press to score the kick and then award the additional point for the valid turn. Mechanisms for doing this may vary, depending on the electronic scoring system in use. If electronic headgear is in use, judges only press to award the valid turn.

Valid turn not scored: In the situation where the referee sees a valid turn that is not scored by the corner judges, the referee may look to the corner judges to determine if the technical point should be added. With confirmation of at least two corner judges (in a three (3) or two (2) judge setting) or the single judge in a one (1) judge setting, the center referee will add the additional points.

Use of head gear not equipped with electronic sensors: All scoring must be done according to the judges’ own determination of accuracy, and there must be equipment available capable of immediately conveying the recorded point to the scoreboard.

Article 14. Prohibited Acts and Penalties

1. Penalties shall be declared by the referee.
2. Prohibited acts described in Article 14 shall be penalized with “Gam-jeom” (deduction penalty).
3. A “Gam-jeom” penalty shall be counted as one (1) additional point for the opposing contestant.
 - 3.1. According to Article 2 (Valid Points), Clause 3.5.1, for a “Gamjeom” given due to passive behavior in the last ten (10) seconds of each round, two (2) points shall be awarded to the opponent.
4. Prohibited acts:
 - 4.1. The following acts shall be classified as prohibited acts, and “Gam-jeom” shall be declared:
 - 4.1.1. Crossing the Boundary Line
 - 4.1.2. Falling down
 - 4.1.3. Avoiding or delaying the match
 - 4.1.4. Grabbing or pushing the opponent
 - 4.1.5. The following are considered prohibited acts:
 - 4.1.5.1. Lifting the leg to block
 - 4.1.5.2. Kicking the opponent’s leg to impede the opponent’s kicking attack
 - 4.1.5.3. Kick was aimed below the waist
 - 4.1.5.4. Lifting the leg above waist for kicking in the air for four (4) times or more
 - 4.1.5.5. Lifting the leg or kicking in the air for more than three (3) seconds to impede opponent’s potential attacking movements
 - 4.1.6. Kicking below the waist
 - 4.1.7. Attacking the opponent after “Kal-yeo”
 - 4.1.8. Hitting the opponent’s head with the hand
 - 4.1.9. Butting or attacking with the knee
 - 4.1.10. Attacking the fallen opponent
 - 4.1.11. Attacking trunk PSS with the side or bottom of the foot in clinch position

4.1.12. Attacking back of head PSS in clinch position

4.1.13. Following misconducts of contestant or coach:

4.1.13.1. Not complying with the referee's command or decision

4.1.13.2. Inappropriate protesting of officials' decisions

4.1.13.3. Inappropriate attempts to disturb or influence the outcome of the match

4.1.13.4. Provoking or insulting the opposing contestant or coach

4.1.13.5. Unaccredited doctor/physicians or other team officials found to be seated in the doctor's position

4.1.13.6. Any other severe misconduct or unsportsmanlike conduct on the part of a contestant or coach

4.1.13.7. When a contestant commits a prohibited act followed by an Attack After Kalyeo (as per article 14.4.1.7) or any other unsportsmanlike behavior (as per article 14.4.1.13) the Referee may give a 2nd Gam-jeom for 'Attack after Kalyeo' or 'Misconduct'.

4.2. When a coach or contestant commits excessive misconduct or refuses to follow the referee's command, the referee may declare a sanction request by first declaring "Gam-jeom" penalty, and then raising a Yellow Card. In this case, the Extraordinary Sanctions Committee shall investigate the contestant's and/or coach's behavior and determine whether a sanction is appropriate in accordance with Article 24.

5. If a contestant intentionally and repeatedly refuses to comply with the Competition Rules or the referee's orders, the referee may end the match by raising a Yellow Card and declaring the opposing contestant the winner.
6. If the referee at the Inspection desk or officials in the ring determine—in consultation with the PSS technician, if necessary—that a contestant or coach has attempted to manipulate the sensitivity of PSS sensor(s) and/or inappropriately alter the PSS to affect its performance, the contestant shall be disqualified.
7. When a contestant receives ten (10) "Gam-jeom" penalties, the referee shall declare the contestant loser by Referee's Punitive Declaration (PUN).
 - 7.1. In the best of three (3) system, when a contestant receives five (5) "Gam-jeom" in a round, the opponent will be declared the winner of that round.
8. In Article 14.1.4, the "Gam-jeom" shall be counted in the total score of the three rounds.

Interpretation

Objectives in establishing the prohibited acts and penalties are as follows:

1. To secure the contestant's safety
2. To ensure fair competition
3. To encourage appropriate techniques

Explanation #1

"Gam-jeom"

i) Crossing the Boundary Line:

- a) A "Gam-jeom" shall be declared when if any part of a contestant's foot crosses the Boundary Line. No "Gam-jeom" will be declared if a contestant crosses the boundary line as a result of a prohibited act by the opposing contestant.

ii) Falling down:

- a) "Gam-jeom" shall be declared for falling down. However, if a contestant falls down due to the opponent's prohibited acts "Gam-jeom" penalty shall not be given to the fallen contestant, while a penalty shall be given to the opponent. If both contestants fall as a result of incidental collision, or in case a contestant who received points with a valid turning kick falls down, no penalty shall be given.

iii) Avoiding or delaying the match:

- a) This act involves stalling with no intention of attacking. A contestant who continuously displays a non-engaging style shall be given a "Gam-jeom". If both contestants remain inactive after three (3) seconds, the center referee will signal the "Gong-gyeok" command. A "Gam-jeom" will be declared: On both contestants if there is no activity from them three (3) seconds after the command was given; or on the contestant who moved backwards from the original position within three (3) seconds after the command was given.
- b) Turning the back and moving away to avoid the opponent's attack should be punished as it expresses the lack of a spirit of fair play and may cause serious injury. The same penalty should also be given for evading the opponent's attack by bending below waist level or crouching.
- c) Retreating from the technical engagement only to avoid the opponent's attack and to run out the clock, "Gam-jeom" shall be given to the passive contestant.
- d) Pretending injury means exaggerating injury or indicating pain in a body part not subjected to a blow for the purpose of demonstrating the opponent's actions as a violation, and also exaggerating pain for the purpose of elapsing the match time. In this case, the referee shall give a "Gam-jeom" however the referee may request IVR for clarification before declaration of "Gam-jeom" for pretending injury.
- e) "Gam-jeom" shall also be given to the athlete who asks the referee to stop the contest in order to adjust the position/fit of protective equipment.

iv) Grabbing or pushing the opponent:

a) This includes grabbing any part of the opponent's body, uniform or protective equipment with the hands. It also includes the act of grabbing the foot or leg or hooking the leg with the forearm. For pushing, it is permitted as a quick impact and a contestant must disengage from the opponent after one push. The following acts shall be penalized:

- Pushing the opponent with prolonged or continuous contact
- Pushing the opponent out of the boundary line
- Pushing the opponent in a way that prevents kicking motion or any normal execution of attacking movement

v) Lifting the leg or cut kick motion shall not be penalized only when it is followed by execution of punching or kicking technique in combination motion.

vi) Attacking below the waist:

a) This action applies to an attack on any part below the waist. When an attack below the waist is caused by the recipient in the course of an exchange of techniques, no penalty will be given. This article also applies to strong kicking or stamping actions to any part of the thigh, knee or shin for the purpose of interfering with the opponent's technique.

vii) Attacking the opponent after "Kal-yeo":

- a) Attacking after Kal-yeo requires that the attack results in actual contact to the opponent's body.
- b) If the attacking motion started before the Kal-yeo, the attack shall not be penalized.
- c) In Instant Video Replay, the timing of Kal-yeo shall be defined as the moment that the referee's Kal-yeo hand signal was completed (with fully extended arm); and the start of the attack shall be defined as the moment that the attacking foot is fully off the floor.
- d) If an attack after Kal-yeo did not land on the opponent's body but appeared deliberate and malicious the referee may penalize the behavior with a "Gam-jeom"

viii) Hitting the opponent's head with the hand:

a) This article includes hitting the opponent's head with the hand (fist), wrist, arm, or elbow. However, unavoidable actions due to the opponent's carelessness such as excessively lowering the head or carelessly turning the body cannot be punished by this article.

ix) Butting or attacking with the knee:

- a) This article relates to an intentional butting or attacking with the knee when in close proximity to the opponent. However, contact with the knee that happens in the following situations cannot be punished by this article.
 - When the opponent rushes in abruptly at the moment a kick is being executed
 - Inadvertently, or as the result of a discrepancy in distance in attacking.

x) Attacking the fallen opponent:

- a) This action is extremely dangerous due to the high probability of injury to the opponent. The danger arises from the following:
- The fallen opponent is in an immediate defenseless state.
 - The impact of any technique which strikes a fallen contestant will be greater due to the contestant's position. These types of aggressive actions toward a fallen opponent are not in accordance with the spirit of Taekwondo and as such are not appropriate to Taekwondo competition. In this regard, penalties should be given for intentionally attacking the fallen opponent regardless of the degree of impact.

When misconduct is committed by a contestant or a coach during a rest period, after five (5) seconds of the round conclusion, the referee can immediately declare the "Gam-jeom" and the "Gam-jeom" shall be recorded to the upcoming round. However, "Gam-jeom" shall be recorded to the previous round if the action happened within five (5) seconds of the round conclusion.

Article 15. Golden Points and Decision of Superiority

1. In the event the winner cannot be decided after three (3) rounds, a fourth (4th) round (golden round) will be conducted in one-minute rounds.
2. In case of a contest advancing to a golden round, all scores awarded during the first three (3) rounds shall be void.
3. The first contestant who scores two (2) or more points or whose opponent receives two (2) "Gam-jeoms" in the golden round shall be declared the winner.
4. In the event that neither contestant has scored two (2) points after the completion of the golden round, the winner shall be decided by superiority based the following criteria:
 - 4.1. The contestant who received a point by a punch in the golden round.
 - 4.2. If neither of the contestants received a point by a punch or both contestants received a point by a punch in the golden round, the contestant who achieved a higher number of hits registered by the PSS during the golden round.
 - 4.3. If number of hits registered by the PSS is tied, the contestant who won more rounds in first three rounds.
 - 4.4. If number of rounds won is tied, the contestant who received less numbers of "Gam-jeoms" during all four rounds.
 - 4.5. If the three above criteria are the same, the referee and judges shall determine superiority based on the content of the golden round. If the superiority decision is tied among the referee and judges, the referee shall decide the winner.
5. In the best of three (3) system, in case of tie score for corresponding round, the round winner shall be decided by superiority based on following criteria:
 - 5.1. Most points scored by turning or spinning kicks.
 - 5.2. If the technical score is the same, the contestant who has more points scored in the order of a higher value techniques as follows (Head, Trunk, Punch, Gam-Jeom).
 - 5.3. If the high value points are the same, the contestant who received a higher number of hits registered by the PSS.
 - 5.4. If the three above criteria are the same, the referee and judges shall determine superiority.
 - 5.4.1. In case of one (1) judge, winner shall be decided by referee, review jury and one (1) judge.
 - 5.4.2. In case of two (2) corner judges, winner shall be decided by referee and two (2) judges.

5.4.3. In case of three (3) corner judges, winner shall be decided by three (3) judges except referee.

Explanation #1:

- i) Decision of superiority by judges shall be based on the initiative shown during the golden round. Initiative is judged in the following order:
- ii) Technical dominance of an opponent through aggressive match management.
- iii) The greater number of techniques executed.
- iv) The use of the more advanced techniques both in difficulty and complexity.
- v) Display of a better competition manner.

Explanation #2:

- i) When head PSS is not in use, in the event that one athlete delivers a successful head kick right before the opponent's body kick, but the later body kick was registered, the coach of the athlete who delivered the successful head kick may ask for video replay. If the Review Jury determines that the head kick was valid and made contact with the head earlier than the body kick, the referee shall invalidate the point(s) scored by the body kick, then award three (3) or six (6) points for the head kick and declare the one who delivered the head kick to be the winner.
- ii) In the event that one athlete who already has one (1) point delivers a successful punch right before the opponent's body kick but only the latest body kick was registered, the coach of the athlete who delivered the punch may request for video replay. If review jury determines that punch was performed earlier than body kick, the referee shall ask whether corner judges scored it or not. If two or more corner judges scored for punch, referee shall invalidate the point(s) scored by body kick, then declare point for punch, and declare the one who delivered the punch as the winner.

Guidelines for Officiating:

- i) Procedure for Superiority decision except for the best of three (3) system shall be as follows:
- ii) Prior to the contest, all refereeing officials take the superiority card with them.
- iii) When a match is to be decided by superiority, the referee shall declare "Woo-se-girok (Record Superiority)".
- iv) Upon the referee's declaration, the judges shall declare the winner within 10 seconds with their heads down, sign the card and then give it to the referee.
- v) The referee shall collect all superiority cards, record the final result, and then declare the winner.
- vi) Upon declaration of the winner, the referee shall hand over the cards to the review jury.

Procedure for Superiority for the best of three (3) system shall be as follows:

- i) When a round is to be decided by superiority, the referee shall declare "Woo-se-girok (Record Superiority)".
- ii) Upon the referee's declaration, the judges declare the winner simultaneously after the Referee's count of three (3) by using round winner hand signal facing the head table.
- iii) In case of one (1) corner judge, the winner shall be decided by the referee, the review jury and one (1) judge.

- iv) In case of two (2) corner judges, the winner shall be decided by the referee and two (2) corner judges.
- v) In case of three (3) corner judges, the winner shall be decided by three (3) corner judges except the referee.
- vi) The Review Jury shall record the final result and declare, to the Operator, the round winner.
- vii) Upon declaration of winner, the referee shall declare the round or match winner.

Article 16. Decisions

1. Win by Referee Stops Contest (RSC)
2. Win by Final Score (PTF)
3. Win by Point Gap (PTG)
4. Win by Golden Points (GDP)
5. Win by Superiority (SUP)
6. Win by Withdrawal (WDR)
7. Win by Disqualification (DSQ)
8. Win by Referee's Punitive Declaration (PUN)
9. Win by disqualification for unsportsmanlike behavior (DQB)
10. In the best of three (3) system, contest decisions are determined as follows:
 - 10.1. Win by Referee Stops Contest (RSC)
 - 10.2. Win by Final Score (PTF)
 - 10.3. Win by Withdrawal (WDR)
 - 10.4. Win by Disqualification (DSQ)
 - 10.5. Win by Disqualification for unsportsmanlike behavior (DQB)

Explanation

- i) Referee Stops Contest: The referee declares RSC in the following situations:
 - a) If a contestant has been knocked down by an opponent's legitimate technique and cannot resume the contest by the count of "Yeo-dul;" or if the referee determines the contestant is not able to resume the competition regardless of the progress of counting
 - b) If a contestant disregards the referee's command to continue the match three times
 - c) If the referee recognizes the need to stop the match to protect a contestant's safety
 - d) When the Medical Staff determines that the match should be stopped due to a contestant's injury
 - e) When an RSC situation occurs, and/or when an athlete's injury influences the decision, TD/CSBs may review the decision at any time.
- ii) Win by final score: Match score shall be the sum of points of the three rounds. The athlete with the higher total score shall be declared the winner.
 - a) In the best of three (3) system, match score shall be the sum of the number of rounds won out of the three (3) rounds. The athlete with the higher total number of rounds won shall be declared the winner.

- iii) Win by point gap:
 - a) When there is a 20-point difference between two athletes at the time of the completion of 2nd round and/or at any time during the 3rd round, the referee shall stop the contest and shall declare the winner by point gap. In a contest having only two rounds, point gap occurs upon completion of the 1st round or any time during the 2nd round.
 - b) Win by point gap shall not be applied in semi-finals & finals in senior division by the outline of the tournament.
 - c) In the best of three (3) system, in case of fifteen (15) points difference between two athletes per round, the referee shall stop the contest and shall declare the winner by point gap for corresponding round. Point gap for corresponding round shall not be applied in semi- finals & finals in senior division by the outline of tournament.
- iv) Win by withdrawal: The winner is determined by withdrawal of the opponent:
 - a) When a contestant withdraws from the match due to injury or other reasons
 - b) When the coach throws a towel into the ring to signify forfeiture of the match
- v) Win by disqualification: This is the result determined by the contestant's failure in weigh-in or when a contestant loses contestant status before the competition begins. The follow-up actions should be different in accordance with the reason of disqualification:
 - a) In the event that athletes have not passed or did not show at weigh-in after draw: The result should be reflected on the draw sheet and the information should be provided to technical officials and all relevant persons. Referees will not be assigned for this match. The opponent of an athlete that did not pass or show up at weigh-in will not need to appear at the court to compete.
 - b) In the event that an athlete passed weigh-in but did not appear at the Coach's Area: The assigned referee and opponent shall be waiting in their position until the referee declares the opponent a winner of the match. Detailed procedure is stipulated in Section 4.1 of Article 10.
- vi) Win by the referee's punitive declaration: The referee declares PUN in the following situations:
 - a) If a contestant has accumulated ten (10) "Gam-jeoms"
- vii) Win by disqualification for unsportsmanlike behavior: DBQ shall be declared in the following situations:
 - a) When a contestant or any member of his/her team is found to be manipulating the sensor(s) or scoring system of the PSS
 - b) When a contestant cheats, or attempts to cheat, the process of weigh-in
 - c) When a contestant is found violating USATKD/WT anti-doping rules
 - d) When a contestant or coach commits serious infringing behavior described in Article 24.1.6 and 24.1.7.
 - e) All results of a contestant who loses by DQB shall be removed, and any other contestants' results affected by the DQB shall be reallocated.

Article 17. Knock Down

1. A Knock Down shall be declared when a legitimate attack is delivered, and:
 - 1.1. When any part of the body other than the sole of the foot touches the floor due to the force of the opponent's scoring technique
 - 1.2. When a contestant is staggered and shows no intention or ability to continue as a result of the opponent's scoring technique
 - 1.3. When the referee judges that, in the interest of safety, the contest cannot continue as the result of a contestant being struck by a scoring technique.

Explanation

Knock down: This is the situation in which a contestant is knocked to the floor or is staggered or unable to respond adequately to the requirements of the match due to a legal scoring technique. Even in the absence of these indications, the referee may interpret as a knock down, the situation where, as the result of contact, it would be dangerous to continue or when there is any question about the safety of a contestant.

Article 18. Procedure in the Event of a Knock Down

1. When a contestant is knocked down as the result of the opponent's legitimate attack, the referee shall take the following measures:
 - 1.1. The referee shall keep the attacker away from the downed contestant by declaration of "Kal-yeo" (break). The recorder shall stop the match clock following the referee's "Kal-yeo" (break) command.
 - 1.2. The referee shall first check the status of the downed contestant and count aloud from "Ha-nah" (one) up to "Yeol" (ten) at one-second intervals towards the downed contestant, making hand signals indicating the passage of time.
 - 1.3. In case the downed contestant stands up during the referee's count and expresses the will to continue the fight, the referee shall continue the count up to "Yeo-dul" (eight) for recovery of the contestant. The referee shall then determine if the contestant is recovered and, if so, continue the contest by declaration of "Kye-sok" (continue).
 - 1.4. When a contestant who has been knocked down cannot demonstrate the will to resume the contest by the count of "Yeo-dul" (eight), the referee shall announce the other contestant winner by RSC (Referee Stops Contest).
 - 1.5. In case both contestants are knocked down, the referee shall continue counting as long as one of the contestants has not sufficiently recovered.
 - 1.6. In case both contestants are knocked down and both contestants fail to recover by the count of "Yeol," the winner shall be decided by the match score before the occurrence of the knock down.
 - 1.7. When it is judged by the referee that a contestant is unable to continue, the referee may decide the winner either without counting or during the counting.
2. Procedure to be followed after the contest:
 - 2.1. Any contestant who is unable to continue the match as a result of a serious injury, regardless of the part of the body, will not be allowed to compete for the next 30 days without an approved medical examination by a medical doctor designated by USATKD, who must certify that the contestant is recovered and able to compete.
 - 2.2. Except for medical emergencies, any contestant with any serious injury must be evaluated by USATKD tournament medical staff for concussion immediately after the contest, using established medical protocols.
 - 2.3. Any contestant who has been knocked out, or loses consciousness for any amount of time, whether briefly or for an extended period of time, or any athlete who does not clear all neurological tests administered by the USATKD Sports Medicine Personnel within 20 minutes of the head injury/contact will have a 50-day (Cadet and younger), 40-day (Junior), and 30-day (Senior and above) out rule applied and may not continue participation that day.

- 2.3.1. Any contestant who has had a second concussion in the last 90 days will get a 90 days suspension and anyone who has a third concussion in the last 180 days will get a 180 days suspension.
- 2.4. The athlete is required to be evaluated by their own doctor at the conclusion of the suspension period and show written release from this physician before being allowed to return to participation. No activity (running, weightlifting, Taekwondo, etc.) is allowed until all signs and symptoms occurring from the head injury have cleared completely. USATKD Sports Medicine Staff reserves the right to refuse to allow an athlete to participate or continue participation if they deem that a head injury has occurred. All athletes sustaining a hit to the head deemed substantial enough to be seen by the USATKD Sports Medicine Personnel must remain under observation for a minimum of 20 minutes.

Explanation:

- i) Keep the attacker away: In this situation, the standing opponent shall return to his/her respective contestant's mark; however, if the downed contestant is on or near the opponent's contestant's mark, the opponent shall stand and wait at the boundary line in front of his/her coach's chair.
- ii) In case the downed contestant stands up during the referee's count and desires to continue the fight: The primary purpose of counting is to protect the contestant. Even if the contestant desires to continue the match before the count of eight is reached, the referee must count until "Yeo-dul" (eight) before resuming the match. Counting to "Yeo-dul" is compulsory and cannot be altered by the referee.
- iii) Counting from one to ten: Ha-nah, Duhl, Seht, Neht, Da-seot, Yeo-seot, Il-gop, Yeo-dul, A-hop, Yeol.
- iv) The referee shall then determine if the contestant has recovered and, if so, restart the contest by the declaration of "Kye-sok": The referee must ascertain the ability of the contestant to continue while he/she counts until eight. Final confirmation of the contestant's condition after the count of eight is only procedural and the referee must not needlessly pass time before resuming the contest.
- v) If a player cannot continue: The contestant expresses the will to continue the match by gesturing several times in a fight position with clenched fists. When a contestant who has been knocked down cannot display this gesture by the count of "Yeo-dul," the referee must declare the other contestant winner (RSC) after first counting "A-hop" and "Yeol". Expressing the will to continue after the count of "Yeo-dul" cannot be considered valid. Even if the contestant expresses the will to resume by the count of "Yeo-dul," the referee can continue counting and may declare the contest over if he/she determines the contestant is incapable of resuming the match.
- vi) When it is judged by the referee that a contestant is unable to continue: When a contestant is downed by a powerful scoring blow and appears to be in serious condition, the referee can suspend the count and call for first aid or do so in conjunction with the count.

Guidelines for Officiating:

- i) The referee must be constantly prepared for the sudden occurrence of a knock down or situation where the contestant is staggered, which is usually characterized by a powerful blow accompanied by impact.
- ii) The referee must not spend additional time confirming the contestant's recovery after counting to "Yeo-dul" as a result of failing to observe that condition during the administration of the count.
- iii) When the contestant clearly recovers before the count of "Yeo-dul" and expresses the will to resume and the referee can clearly discern the contestant's condition yet resumption is hampered by the requirement of medical treatment, the referee must declare "Kye-shi" (injury time-out) and then follow the procedures of Article 19.

Article 19. Procedures for Suspending the Contest

1. When a contest is to be stopped due to the injury of one or both contestants, the referee shall take the measures prescribed below. However, in a situation which warrants suspending the contest for reasons other than an injury, the referee shall declare "Kal-yeo (break)" and resume the contest by declaring "Kye-sok (continue)".
 - 1.1. The referee shall suspend the contest by declaration of "Kal-yeo" and order the recorders to suspend the time.
 - 1.2. The referee shall allow the contestant one minute to receive first aid by the commission doctor; the referee may allow team doctor to treat first aid if the commission doctor is not available or if it is deemed necessary.
 - 1.2.1. The commission doctor may request more time (up to 2 minutes) if necessary.
 - 1.2.2. If there is no commission doctor, team doctor or medical chairman available, any doctor (or medical associate) near the competition mat can be requested to provide the athlete with first aid.
 - 1.3. If an injured contestant cannot return to the match after one minute the referee shall declare the other contestant winner.
 - 1.4. In case resumption of the contest is impossible after one minute, the contestant causing the injury by a prohibited act to be penalized by "Gam-jeom" shall be declared the loser.
 - 1.5. In case both the contestants are knocked down and are unable to continue the contest after one minute, the winner shall be decided upon points scored before the injuries occurred.
 - 1.5.1. In case of best of three (3) System: If both contestants are knocked down and are unable to continue the contest after one minute at Round 1 or Round 3, the winner shall be determined by the points scored before the injuries occurred in the pertinent Round. If this occurs during Round 2, the winner shall be determined by the decision of Round 1.
 - 1.5.2. If points are tied, the winner shall be decided according to criteria of superiority.
 - 1.6. If the referee determines a contestant's pain is caused only by a bruise the referee shall declare "Kal-yeo" and give a command to resume the match with the call, "stand-up". If the contestant refuses to continue the match after the referee gives the command "stand up" three times, the referee shall declare the match 'Referee Stops Contest'.
 - 1.7. If the referee determines a contestant has received an injury such as broken bone(s), dislocation, sprained ankle(s), and/or bleeding, the referee shall allow the contestant to receive a first aid treatment for one minute after "Kyeshi". The referee may allow the contestant to receive first aid treatment even after giving the commanding "standup" if the contestant is determined to be injured in one of the categories above.

- 1.8. Stopping the match due to injury: If the referee determines a contestant has received an injury such as broken bone(s), dislocation, sprained ankle(s), and/or bleeding, the referee shall consult with the chairperson of the Medical Committee or the commissioned doctor assigned by the chairperson. If a contestant is re-injured in the same manner, the chairperson of the Medical Committee or the commission doctor assigned by the chairman may advise the referee to stop the match and declare the injured the loser.

Explanation #1

When the referee determines that the competition cannot be continued due to injury or any other emergency, he/she may take the following measures:

- i) If the situation is critical, such as a contestant losing consciousness or suffering from severe injury and time is crucial, first aid must be immediately directed first, and the match must be closed. In this case, the result of the match will be as follows:
 - a) The contestant causing the injury shall be declared the loser if the outcome was the result of a prohibited act to be penalized by "Gam-jeom".
 - b) The incapacitated contestant shall be declared the loser if the outcome was the result of a legal action or accidental, unavoidable contact.
 - c) If the outcome was unrelated to the match contents, the winner shall be decided by the match score before suspension of the match. If the suspension occurs before the end of the first round, the match shall be invalidated. If points are tied, the winner shall be decided according to the criteria of superiority.
 - d) In case of best of three (3) System:
 - If the outcome was unrelated to the match contents, the winner shall be determined by the points scored before the suspension occurred in the pertinent Round (in case of the Round 1 or 3). If points are tied, the winner shall be decided according to the criteria of superiority.
 - If this occurs in Round 2, the winner shall be determined by the decision of Round 1.
- ii) If first aid treatment is needed for an injury, the contestant can receive necessary treatment within one minute after the declaration of "Kye-shi".
 - a) Order to resume the match: It is the decision of the center referee, after consultation with the Commission Doctor, whether or not it is possible for the contestant to resume the match. The referee can anytime order the contestant to resume the match within one minute. The referee can declare any contestant who does not follow the order to resume the match the loser of the contest.
 - b) While the contestant is receiving medical treatment or is in the process of recovering, 40 seconds after the declaration of "Kye-shi", the referee begins to loudly announce the passage of time in five second intervals. When the contestant cannot return to the Contestant's Mark by the end of the one minute period, the match results must be declared.
 - c) After the declaration of "Kye-shi", the one-minute time interval must be counted from the moment the commission doctor enters the mat or after waiting for commission doctor up to 10 seconds if not readily available in the mat. However, when the doctor's treatment is required but the doctor is absent or additional treatment is necessary, the one-minute time limit can be suspended by the judgment of the referee.

- d) If resumption of the match is impossible after one minute, the decision of the match will be determined according to sub-article “i” of this article.
- iii) If both contestants become incapacitated and are unable to resume the match after one minute or urgent conditions arise; the match result is decided according to the following criteria:
 - a) If the outcome is the result of a prohibited act to be penalized by “Gam-jeom” by one contestant that person shall be the loser.
 - b) If the outcome was not related to any prohibited act to be penalized by “Gam-jeom”, the result of the match shall be determined by the match score at the time of suspension of the match. However, if the suspension occurs before the end of the first round, the match shall be invalidated, and the Organizing Committee will determine an appropriate time to re-contest the match. The contestant who cannot resume the match shall be deemed to have withdrawn from the match.
 - c) In case of best of three (3) System:
 - If the outcome was unrelated to “Gam-jeom” penalty, the contest result shall be determined by the points scored before the suspension occurred in the pertinent Round (in case of Round 1 or 3).
 - If the points are tied, the winner shall be determined according to the criteria of superiority. If this occurs in the Round 2, the winner shall be determined by the decision of Round 1.
 - If the outcome is the result of prohibited acts to be penalized by “Gam-jeom” by both contestants, then both contestants shall lose.

Explanation #2

The situation in which warrants suspending the match beyond the above prescribed procedures shall be treated as follows.

- i) When uncontrollable circumstances require suspension of the match, the referee shall suspend the match and follow the directives of the Technical Delegate.
- ii) If the match is suspended after the completion of the second round, the outcome shall be determined according to the match score at the time of suspension.
 - a) In case of best of three (3) System, if the match is suspended
 - The outcome shall be determined by the point scored before the suspension occurred in pertinent Round in case of Round 1 or Round 3 of the contests.
 - (1) If points are tied, the winner shall be decided according to the criteria of superiority.
 - In case of the occurrence during Round 2, the winner shall be decided upon decision of Round 1.
- iii) If the match is suspended before the conclusion of the second round, a rematch shall, in principle, be conducted and shall be held in three rounds.

Article 20. Technical Officials

1. Technical Delegate (TD)

1.1. Qualification: USATKD Executive Director shall appoint TD.

1.2. Role

1.2.1. TD is responsible for ensuring that USATKD Competition Rules are properly applied and preside over the Head of Team meeting and drawing of lots of session.

1.2.2. TD approves the result of draw, weigh-in and competitions before it being officialized.

1.2.3. TD has the right to make final decisions on competition area and overall technical matters on competitions in consultation with Competition Supervisory Board.

1.2.4. TD shall make final decisions on any matters pertaining to competitions not prescribed in Competition Rules.

1.2.5. TD serves as the Chairman of Competition Supervisory Board.

1.2.6. TD is responsible for reporting event evaluation.

2. Competition Supervisory Board (CSB) Member

2.1. Qualification: CSB members shall be appointed by the USATKD Executive Director

2.2. Composition

2.2.1. CSB shall consist of one chairperson and no more than 4 members at the championships. The composition, however, may be adjusted by the USATKD Executive Director, if necessary.

2.2.1.1. Games Committee

2.2.1.2. Referee Committee

2.2.1.3. Medical Committee

2.2.1.4. Athlete Committee

2.3. Roles

2.3.1. CSB shall assist TD in competitions and technical matters and ensure the competitions are held in accordance with the schedule.

2.3.2. CSB shall evaluate the performances of Review Jury and refereeing officials.

2.3.3. CSB shall also concurrently act as the Extraordinary Sanctions Committee during competition with regard to competition management matters.

3. Refereeing Officials

3.1. Qualification

3.1.1. Holder of Referee Certification registered by USATKD and/or the WT.

3.1.2. Must be a USATKD member in good standing.

3.2. Duties

3.2.1. Referee

3.2.1.1. The referee shall have control over the match.

3.2.1.2. The referee shall declare “Shi-jak”, “Keu-man”, “Kal-yeo”, “Kye-sok”, “Kye-shi”, “Shi-gan”, winner and loser, deduction of points, penalty, and retiring. All the referees’ declarations shall be made after the results are confirmed.

3.2.1.3. The referee shall have the right to make decisions independently in accordance with the prescribed rules.

3.2.1.4. In principle, the center referee shall not award points. However, if one of the corner judges raises his/her hand because a point was not scored, then the center referee will convene a meeting with the judges. If it was found that two corner judges request for change of the judgment, the referee must accept and correct the judgment (in case of 1 referee + 3 judges). In a two-corner judge setting, the result of the scoring can be revised when two persons among two judges and the referee agree to do so.

3.2.1.5. In case as defined by Article 15, the decision of superiority shall be made by refereeing officials after the end of four (4) rounds or end of each round in best of three competitions when necessary.

3.2.2. Judges

3.2.2.1. The judges shall mark the valid points immediately.

3.2.2.2. The judges shall state their opinions forthrightly when requested to do so by the referee.

3.2.3. Review Jury (RJ)

3.2.3.1. RJ shall review an instant replay and inform the referee of the decision within thirty (30) seconds.

3.2.4. Technical Assistant (TA)

- 3.2.4.1. TA shall keep monitoring scoreboard during the contest if the scoring, penalties and timing are correctly publicized and immediately notify the referee of any problematic issue in this regard.
- 3.2.4.2. TA shall notify the referee of starting or stopping the contest in close communication with system operator and recorder.
- 3.2.4.3. TA manually records all scores, penalties and IVR result in TA paper.

3.2.5. Ring Captain (RC)

- 3.2.5.1. Qualification: The Ring Captain shall be an experienced, highly qualified USATKD Referee appointed by the USATKD Referee Chairman.
- 3.2.5.2. One Ring Captain shall be allocated per court.
- 3.2.5.3. The Ring Captain manages the ring and assigns refereeing officials for the court he/she is responsible for, and may also serve as a Referee, Judge, Technical Assistant or Review Jury for that court.

3.2.6. Computer Operator

3.3. Composition of refereeing officials per court

- 3.3.1. The officials' squad is composed of one (1) referee and three (3) judges.
- 3.3.2. The officials' squad is composed of one (1) referee and two (2) judges
- 3.3.3. The officials' squad is composed of one (1) referee and one (1) judge.

3.4. Assignment of refereeing officials

- 3.4.1. The assignment of the referees and judges shall be made after the contest schedule is fixed.
- 3.4.2. Referees and judges from the same state or country for international competitions as those of either contestant shall not be assigned to such a contest. However, an exception can be made for the judges when the number of refereeing officials is insufficient.

3.5. Responsibilities for decisions

- 3.5.1. Decisions made by the referees and judges shall be conclusive and they shall be responsible to the Competition Supervisory Board for the content of those decisions.

3.6. Uniforms

- 3.6.1. The referees and judges shall wear the uniform designated by the USATKD.

3.6.2. The refereeing officials shall not carry or take any materials to the contest area which might interfere with the contest. Refereeing officials should not use mobile phones in the competition area.

4. Recorders:

4.1. The recorder shall time the contest, periods of time-out, and suspensions, and also shall record and publicize the awarded points, and/or penalties.

Guidelines for Officiating

Replacement of officials: The Chair of the Competition Supervisory Board may request the USATKD Referee Chairman for that event or USATKD designee to replace the refereeing officials in the event that refereeing officials have been mis-assigned, or when it is judged that any of the assigned refereeing officials have unfairly conducted the contest or made unjustifiable mistakes repeatedly.

Article 21. Instant Video Replay

1. For USATKD-organized competitions, (where possible and/or feasible) Video Replay will be used.
2. In case there is an objection to a judgment of the refereeing officials during the contest, the coach of a team can make a request to the center referee for an immediate review of the video replay. The coach can only request video replay for following:
 - 2.1. Penalties against the opponent for instances of falling down or crossing the boundary line or attacking the opponent after "Kal-yeo" or attacking the fallen opponent.
 - 2.2. Technical point.
 - 2.3. Any penalty against own contestant.
 - 2.4. When referee forgot to invalidate point(s) after "Gam-jeom" was given for prohibited act.
 - 2.5. Wrong identification of fist attacking contestant by judge.
 - 2.6. Head kick that is not scored, only when Head PSS is not in use.
3. When coach appeals, the center referee will approach the coach and ask the reason for the appeal. Any appeal shall not be admissible on any points scored by foot or fist attacks on the trunk or foot attack on trunk and head PSS. Instant Video Replay (IVR) for head kicks may be requested by the coach only when the Head PSS is not in use and the Conventional Head Protector is applied. The scope of Instant Video Replay (IVR) request is limited to the only one action which has occurred within five (5) seconds from the moment of the coach's request. Once the coach raises the blue or red card to request for instant video replay, it will be considered that the coach has used his/her allocated appeal under any circumstance unless the judge's meeting satisfies the coach.
4. Referee shall request the Review Jury to review the instant video replay. Review Jury, shall review the video replay.
 - 4.1. In the last five (5) seconds of any Round, the Center Referee may request for IVR review to check the possible Gam-jeom penalties for the following actions:
 - 4.1.1. Falling down.
 - 4.1.2. Crossing the boundary line.
 - 4.1.3. Attack after Kal-yeo.
 - 4.1.4. Attack the fallen opponent.

*Any points scored after Prohibited Act will be invalidated.

- 4.2. If a referee perceives a contestant to be staggering, a strong impact to the head, kick to the eye(s), bleeding or knocked down by a kick to the head, and so begins counting, but the attack was not scored by the head PSS, the referee must request IVR to make the decision for awarding or not awarding points after the count.
- 4.3. Referee may request IVR for clarification before declaration of "Gam-jeom" for pretending injury.
- 4.4. When a situation arises in the last ten (10) seconds of a round in which the referee's requested decision under Article 12.3.5.1 cannot be clearly determined by the Review Jury, the TD and/or CSB may review the decision upon request by the Review Jury.
5. Apart from video replay, the coach of a team may use a technical card for Technical Review Request to immediately request the center referee to resolve issues, regardless of any round. However, if the review jury confirms that there is no fault in the requested matter, a "Gam-jeom" shall be imposed on the contestant of the requesting coach. In such case, the technical card shall be returned to the coach for reuse, regardless of the result. The coach may request a Technical Review in the following cases;
 - 5.1. Any mechanical malfunction or error in time management.
 - 5.2. In case of appeal for PSS mechanical malfunction.
 - 5.3. When referee forgot to invalidate point(s) after "Gam-jeom" was given for prohibited act
 - 5.4. When the operator incorrectly registers the referee's declaration related to "Gam jeom" or valid points in operating the system.
 - 5.5. In cases corresponding to Article 21.8.
6. After reviewing the instant video replay, the Review Jury shall inform the center referee of the final decision within thirty (30) seconds after receiving the request.
7. Coach shall be allocated with one (1) appeal to request an instant video replay request per each contest. However, based on the size and level of the Championships, the Technical Delegate may decide the number of appeal quota during the head of team meeting. If the appeal is successful and the contested request is corrected, the coach shall retain the appeal right for the pertinent contest.
8. The decision of the Review Jury is final; no further appeals during the contest or protest after the contest will be accepted except errors in the calculation of scoring in contest of Olympic Qualification Tournaments, G6 event or above as explained Article 21.8.1.
9. In the case that there is a clear erroneous decision from the refereeing officials and scoring operators on identification of the contestant or errors in the calculation of scoring as follows:
 - 9.1. Score and Gam-jeom input by Operator.
 - 9.2. Misidentification of athletes by Center Referee

- 9.3. Any of the refereeing officials shall request IVR and correct the decision at any time during the round.
- 9.4. If errors in calculation of scoring or misidentification of the athlete were not corrected during the round by the refereeing officials and the errors subsequently affected the result of the winner of the contest or the round the Technical Delegate (TD) has the right to review the case with assistance of the Competition Supervisory Board (CSB) to make the necessary correction within 30 minutes after the pertinent round. If the errors were identified and confirmed, the TD may request for resumption of the round from the moment when the error occurred. In case of multiple errors, competition will be resumed from the moment when the first error occurred.
10. In the case of a successful appeal, the Competition Supervisory Board may investigate the contest at the end of the competition day and take disciplinary action against the refereeing officials concerned, if necessary.
11. In any time during the round, any of the judges can ask for adding or removing technical points regardless of coach's appeal quota.
12. In the tournament where instant video replay system is not available, the following protest procedure will be applied.
 - 12.1. In case there is an objection to a referee judgment, an official delegate of the team must submit an application for re-evaluation of decision (protest application) together with the non-refundable protest fee of US\$200 to the Board of Arbitration (Competition Supervisory Board) within 10 minutes after pertinent contest.
 - 12.2. Deliberation of re-evaluation shall be carried out, and resolution on deliberation shall be made by majority.
 - 12.3. The members of the Board of Arbitration (Competition Supervisory Board) may summon the refereeing officials for confirmation of events.
 - 12.4. The resolution made by the Board of Arbitration (Competition Supervisory Board) will be final and no further means of appeal will be applied.
 - 12.5. Deliberation procedures are as follows:
 - 12.5.1. A coach or head of team shall be permitted to make a brief verbal presentation to the Board of Arbitration in support of their position. The coach or head of team from the respondent athlete shall be allowed to present a brief rebuttal.
 - 12.5.2. After reviewing the protest application, the contest of the protest must be arranged according to the criterion of "Acceptable" or "Unacceptable".
 - 12.5.3. If necessary, the Board can hear opinions from the referee or judges.

12.5.4. If necessary, the Board can review the material evidence of the decision, such as the written or visual recorded data.

12.5.5. After deliberation, the Board shall hold the secret ballot to determine a majority decision.

12.5.6. The Chairperson will make a report documenting the outcome of the deliberation and shall make this outcome publicly known.

12.5.7. Subsequent process following the decision:

12.5.7.1. Errors in determining the match results, mistakes in calculating the match score or misidentifying a contestant shall result in the decision being reversed.

12.5.7.2. Error in application of the rules: When it is determined by the Board that the referee made a clear error in applying the Competition Rules, the outcome of the error shall be corrected and the referee shall be punished.

12.5.7.3. Errors in factual judgment: When the Board decides that there was a clear error in judging the facts such as impact of striking, severity of action or conduct, intention, timing of an act in relation to a declaration or area, the decision shall not be changed and the officials seen to have made the error shall be reprimanded.

Article 22. Team Competition

This article outlines the modifications to the competition rules used for team competitions. The purpose is to define the competition format, weight categories, team composition, scoring system, and other operational procedures for junior and senior team competitions. For matters not prescribed in Article 22, the USATKD competition rules shall apply.

1. Event Categories & Divisions

- 1.1. The team competition event divisions and categories including the total weight range of each category are outlined in Article 5 of the competition rules.
- 1.2. The age criteria for the senior and junior divisions are defined in accordance with Article 4 of the competition rules.

2. Competition Area

- 2.1. Team Competitions shall be held in the standard USATKD competition area (octagonal mat) as specified in Article 3 of the USATKD competition rules.
- 2.2. Any modifications required to accommodate team relay format must receive prior approval from USATKD technical committee.

3. Method of Competition

- 3.1. Unless otherwise stated in the event outline, Team Competitions shall be conducted as a single-elimination tournament with bronze medal contests
- 3.2. The Best of Three system shall apply for the Team Competitions. The contest result shall be determined by the number of rounds won out of the three rounds.
- 3.3. Team competitions shall be conducted in tag-match format in each round.
 - 3.3.1. Unlimited substitutions (tags) are allowed. However, once an athlete is substituted in, they must remain in the contest for at least 15 seconds before being eligible for substitution again.
 - 3.3.2. After a substitution, the opposing team may not substitute their athlete for the next 10 seconds.
- 3.4. Team ranking may be applied for seeding, when applicable
- 3.5. Instant Video Replay shall not be applied in Team Competitions.

4. Team Composition

- 4.1. Each team may register up to the maximum number of athletes required for each event, plus one (1) reserve athlete per gender.
- 4.2. For example, in the male team of three competition, a maximum of four (4) athletes may be registered. No reserve athlete is allowed for Pair events.
- 4.3. Each team must submit the entry list prior to each contest.
- 4.4. Athlete replacement with a reserve athlete is permitted only between contests, not during a contest
- 4.5. A maximum of two (2) coaches and one (1) medical staff member are allowed to enter the field of play. Only the coaches may enter the competition area to manage substitutions during a contest.

5. Duration of Contest

- 5.1. In the best-of-three system, the contest shall consist of three (3) rounds of three (3) minutes each, with a one (1) minute rest period between rounds.
- 5.2. The duration of each round may be adjusted to 2-minute x 3 rounds in case of pair events.
- 5.3. The duration and number of rounds for Junior competitions may be modified depending on the event structure and shall be announced in the outline.

6. Weigh-in

- 6.1. Athletes must undergo and pass the official weigh-in procedures in accordance with Article 9 of the USATKD competition rules.
- 6.2. The combined weight of the selected athletes must not exceed the weight limit specified for the respective events.
- 6.3. No random weigh-in will be conducted for the team competition.

7. Valid Points and Scoring

- 7.1. Valid points and scoring in team competitions shall be determined in accordance with Articles 12 and 13 of the USATKD competition rules.
- 7.2. Each athlete's points shall contribute to the team's total accumulated score.

8. Competition may also be conducted using the Health Bar System in addition to the formats specified in the USATKD Competition Rules. The Health Bar System shall operate as follows:

8.1. Health Bar System

- 8.1.1. Each team shall begin with a Health Bar of 150 points.

- 8.1.2. Points scored by an athlete shall be deducted from the opposing team's Health Bar.
- 8.1.3. A round shall end when one team's Health Bar reaches zero (0), in which case the opposing team shall be declared the winner of that round.
- 8.1.4. If neither team's Health Bar reaches zero (0) within the allotted time, the team with the higher remaining Health Bar shall be declared the winner of the round.

9. Scoring Area Health Bar (Total 150)

- 9.1. Valid Punch to Trunk Protector - 5
- 9.2. Valid Kick to the Trunk Protector - 10
- 9.3. Valid Kick to the Head - 15
- 9.4. Valid Turning Kick to Trunk Protector - 20
- 9.5. Valid Turning Kick to the Head - 30
- 9.6. Gam-jeom -5
 - 9.6.1. Passive behavior deduction X2 for 10 seconds

10. Prohibited Acts and Penalties

- 10.1. The following acts shall be classified as prohibited acts, and a "Gam-jeom" shall be declared.
 - 10.1.1. Grabbing the opponent
 - 10.1.2. Attacking the opponent after "Kal-yeo"
 - 10.1.3. Attacking the fallen opponent
 - 10.1.4. Crossing the boundary line
 - 10.1.5. Misconduct by contestant(s) or coach
- 10.2. Each "Gam-jeom" shall result in one (1) point awarded to the opposing contestant.
- 10.3. The team that accumulates 40 Gam-jeoms at any point during the contest shall be declared the loser.
- 10.4. Passive Penalty: In cases where a contestant is deemed to be avoiding the match or displaying passive behavior, the following shall apply:
 - 10.4.1. A passive penalty shall be declared against the contestant. For the next ten (10) seconds, the opponent shall be granted the advantage of doubling the value of any points scored.

10.4.2. The corresponding amount shall be deducted from the Health Bar of the passive contestant's team if the Health Bar System is used.

10.4.3. Passive penalties may be given for the following actions:

10.4.3.1. Running away from the opponent.

10.4.3.2. Intentionally falling down

10.4.3.3. Intentionally avoiding or delaying the match

10.5. Repeated offenses or unsportsmanlike behavior may result in disqualification of the individual athlete or the team, at the discretion of the Referee and Technical Delegate.

11. Competition Format

11.1. Male and Female Pair

11.1.1. Each team must register a minimum of two (2) and a maximum of three (3) athletes, including one (1) reserve.

11.1.2. Each contest must begin with two (2) starting athletes.

11.1.3. Teams must submit the entry list prior to each contest. The combined weight of the entered athletes must not exceed the weight limit of the respective division. No changes to the entry list are permitted once it has been submitted.

11.1.4. Contests consist of three (3) (or two (2)) rounds of two (2) minutes each, with a one-minute break between rounds.

11.1.5. Unlimited substitutions (tags) are allowed. However, once an athlete is substituted in, they must remain in the contest for at least 15 seconds before being eligible for substitution again. Additionally, after a substitution, the opposing team may not substitute their athlete for the next 10 seconds.

11.1.6. Substitutions can only occur when the match is reasonably interrupted.

11.2. Male Team and Female Team

11.2.1. Each team shall register the required number of athletes for the respective events.

11.2.1.1. Team of Three: three (3) athletes.

11.2.1.2. Team of Four: four (4) athletes.

11.2.1.3. In addition, each team may register one (1) reserve athlete.

11.2.2. Each contest must begin with three (3) or four (4) starting athletes, depending on the event.

11.2.2.1. Team of Three: three (3) athletes.

11.2.2.2. Team of Four: four (4) athletes).

11.2.3. Teams must submit the entry list prior to each contest.

11.2.3.1. The combined weight of the entered athletes must not exceed the weight limit of the respective division. No changes to the entry list are permitted once it has been submitted.

11.2.3.2. Contests consist of three (3) (or two (2)) rounds of three (3) minutes each, with a one-minute break between rounds.

11.2.4. Unlimited substitutions (tags) are allowed. However, once an athlete is substituted in.

11.2.4.1. They must remain in the contest for at least 15 seconds before being eligible for substitution again.

11.2.4.2. After a substitution, the opposing team may not substitute their athlete for the next 10 seconds.

11.2.4.3. Substitutions can only occur when the match is reasonably interrupted.

11.2.5. In the event of an injury during the competition, a Team of Four may continue the contest with three (3) athletes.

11.3. Mixed Team

11.3.1. Each team must register at least two (2) female and two (2) male athletes, with a maximum of six (6) athletes including two (2) reserves (one per gender).

11.3.2. Each contest must include four (4) starting athletes: two (2) female and two (2) male.

11.3.3. Teams must submit the entry list prior to each contest. The combined weight of the selected athletes must not exceed the weight limit of the respective division. No changes to the entry list are permitted once it has been submitted.

11.3.4. Athletes are numbered from 1(lighter) to 2 (heavier) for female and 3(lighter) and 4 (heavier) for male athletes.

11.3.5. Contests consist of three (3) (or two (2)) rounds of three (3) minutes each, with a one-minute break between rounds.

11.3.6. The 1st round shall start with Choice of Chung's female athlete.

11.3.7. The 2nd round shall start with choice of Hong's female athlete.

- 11.3.8. In case of 3rd round, it shall start with the male athlete.
- 11.3.9. Each side must match same gender for every bout.
- 11.3.10. Unlimited substitutions (tags) are allowed. However, once an athlete is substituted in, they must remain in the contest for at least 15 seconds before being eligible for substitution again. Additionally, after a substitution, the opposing team may not substitute their athlete for the next 10 seconds.
- 11.3.11. Substitutions can only occur when the match is reasonably interrupted.
- 11.3.12. In the event of an injury during the competition, Mixed Gender Teams may continue with a team of three (3) athletes.
- 11.3.13. Male athletes in Mixed Team Competition must wear black Kyorugi competition uniform (Dobok) pants.

12. Decisions

- 12.1. In Team Competitions, contest outcomes shall be determined in accordance with Article 16 of the USATKD Competition Rules, as follows:
 - 12.1.1. Win by Referee Stops Contest (RSC)
 - 12.1.2. Win by Final Score (PTF)
 - 12.1.3. Win by Withdrawal (WDR)
 - 12.1.4. Win by Disqualification (DSQ)
 - 12.1.5. Win by Disqualification for unsportsmanlike behavior (DQB)
- 12.2. No point gap rule shall be applied in Team Competitions, however, if a team reaches 30 points first, that team will be declared the winner of that round.
- 12.3. In Team of Four and Mixed Team competitions, when four (4) athletes are competing and any of the situations described in Article 16.
- 12.4. Explanation 1 of the USATKD Competition Rules occurs to one (1) of the athletes, the Referee may ask the team's coach whether they wish to continue the contest with three (3) athletes. If the coach declines, the Referee shall declare the opposing team the winner, and the result of the contest shall be recorded as Win by Referee Stops Contest (RSC).
- 12.5. In the event of a tied score at the end of a round, the winner of that round shall be determined in accordance with Article 15.5 of the USATKD Competition Rules.

13. Protests and appeals shall be submitted in accordance with the USATKD Protest and Appeals Procedure.
14. Any unforeseen matters not specified in this Article shall be decided by the Technical Delegate in consultation with the Competition Supervisory Board.
15. For Team Competitions, any rules not expressly stated in this Article shall be governed by the USATKD Competition Rule.

Article 23. Protest and Arbitration

1. Competition Supervisory Board

1.1. Purpose

- 1.1.1. In the interest of maintaining fairness, integrity, and responsiveness during competitive events, this rule provides a formal mechanism to address any and all matters not explicitly covered by the existing competition rules.
- 1.1.2. Matters relating to a contest shall be decided through consensus by a Competition Supervisory Board (CSB).
- 1.1.3. Matters not related to a specific contest through the event shall be decided by the USATKD Managing Director of Operations or their designee.

1.2. Qualifications of the members:

- 1.2.1. Qualified Competition Supervisory Board members shall be persons with sufficient Taekwondo experience recommended by the USATKD Executive Director or his/her designee.

1.3. Composition:

- 1.3.1. One (1) Referee Chair or their designee.
- 1.3.2. One (1) credentialed coach, selected by the USATKD Performance Department, Coach Advisory Group or onsite USATKD events management lead.
- 1.3.3. One (1) athlete representative, eligible and participating in the current event.
- 1.3.4. One (1) USATKD staff member, designated by the USATKD Executive Director, USATKD Managing Director of Operations or designee.
- 1.3.5. One (1) Medical Staff member, designated by the USATKD Event Managing Director.
- 1.3.6. If there are officials from the same state or the same training affiliation, as either contestant involved on the Competition Supervisory Board, those members must be excluded from the Board. In all cases, the number of Board members must be an odd number. If the Chair is one who is ineligible, a temporary chair must be elected by the remaining members.
- 1.3.7. For USATKD owned, operated or sanctioned events, the CSB for each event will be appointed prior to the beginning of the tournament.
- 1.3.8. The chair and members of the Competition Supervisory Board will be appointed by the USATKD Executive Director or his/her designee.

1.4. Responsibility

1.4.1. The Competition Supervisory Board shall adjudicate protests and correct misjudgments if necessary. In their concurrent capacity as the Extraordinary Sanctions Committee (see Article 24), the Competition Supervisory Board may also take disciplinary action against the officials committing the infraction. Documented records and results shall be sent to the USATKD Executive Director.

1.4.2. The Chair of the Competition Supervisory Board may recommend that the USATKD Referee Chairman for that event or USATKD designee replace referees or judges.

1.5. Protest Procedure After the Match

1.5.1. In case there is an objection to a referee judgment or the competition rules are not clearly addressed in the published competition rules, procedures, or guidelines and cannot be resolved with the officiating team, within 10 minutes after the pertinent contest, the certified coach representing the athlete may submit an application for re-evaluation of decision (protest application) together with the prescribed, non-refundable fee of one hundred dollars (\$100.00) to the USATKD Event Director.

1.5.2. Deliberation of re-evaluation shall be carried out excluding those members of the same state or training affiliation as that of either contestant concerned, and resolution shall be made by majority vote.

1.5.3. The members of the Competition Supervisory Board may summon the refereeing officials for confirmation of events. Video tapes will not be admitted as evidence.

1.5.4. The resolution made by the Competition Supervisory Board will be final and no further means of appeal will be applied.

1.5.5. Deliberation procedures are as follows:

1.5.5.1. A coach or head of team from the protesting side shall be permitted to make a brief verbal presentation to the Board of Arbitration in support of their position. The coach or head of team from the respondent side shall be allowed to present a brief rebuttal.

1.5.5.2. After reviewing the protest application, the content of the protest must be arranged according to the criterion of "Acceptable" or "Unacceptable."

1.5.5.3. If necessary, the Board can hear opinions from the referee or judges.

1.5.5.4. If necessary, the Board can review all relevant circumstances and available evidence, such as the written records (TA Paper, score sheets, tally sheets), or electronic records of the match.

1.5.5.5. If necessary, the Board can interview involved parties and witnesses.

- 1.5.5.6. If necessary, the Board can recommend or implement solutions, remedies, or disciplinary actions, even if those remedies are not explicitly detailed in the existing rulebook, provided they are grounded in fairness, integrity, and the safety and well-being of the athletes.
- 1.5.5.7. If necessary, the Board can issue temporary rulings or guidance for the remainder of the event if immediate resolution is required.
- 1.5.5.8. After deliberation, the Board holds a secret ballot to determine a majority decision.
- 1.5.5.9. The Chair will make a report documenting the outcome of the deliberation and shall make this outcome publicly known.
- 1.5.5.10. Subsequent process following the decision:
 - 1.5.5.10.1. Errors in determining the match results, mistakes in calculating the match score or misidentifying a contestant shall result in the decision being reversed.
- 1.5.5.11. When it is determined by the Board that the referee made a clear error in applying the Competition Rules, the outcome of the error shall be corrected, and the referee may be admonished or face sanction.
- 1.5.5.12. When the Board decides that there was a clear error in judging the facts such as the impact of striking, severity of action or conduct, intention, timing of an act in relation to a declaration or area, the decision shall not be changed, and the official(s) seen to have made the error shall be reprimanded.
- 1.5.5.13. The Board may request the USATKD Referee Chairman for that event or USATKD designee to replace the refereeing officials in the event that refereeing officials have been mis-assigned, or when it is judged that any of the assigned refereeing officials have unfairly conducted the contest or made unjustifiable mistakes repeatedly.

1.6. The CSB shall operate under the following principles:

- 1.6.1. Fairness over Formalism: When rules are silent, fairness and athlete protection will prevail.
- 1.6.2. Transparency and Accountability: All actions taken will be documented and reported post-event for transparency and possible rule amendments.
- 1.6.3. Inclusivity: Solutions will prioritize the inclusive spirit of Taekwondo and consider the diverse needs of all participants.

1.7. Post-Event Review

- 1.7.1. Decisions made by a CSB during an event will be subject to post-event review by USATKD leadership, with the opportunity to codify new precedents or propose rulebook amendments for future clarity.

Article 24. Sanction Procedure

1. Procedure of Sanction
 - 1.1. The composition of the Extraordinary Sanctions Committee shall be the same as that of the Competition Supervisory Board.
 - 1.2. The USATKD Executive Director (or his/her designee) may request that an Extraordinary Sanctions Committee be convened for deliberation when inappropriate behaviors may have been committed by a coach, a contestant, official, and/or any Organizing Committee member.
 - 1.3. The Extraordinary Sanctions Committee shall investigate the matter, and summon person(s) concerned for confirmation of events.
 - 1.4. The deliberation procedure of sanction shall correspond to that of the Competition Supervisory Board and shall be consistent with due process protections guaranteed by the Ted Stevens Olympic and Amateur Sports Act and USATKD bylaws.
 - 1.5. The Extraordinary Sanctions Committee shall deliberate the matter, and recommend what, if any, disciplinary actions to impose. The recommendation shall be reported in writing, together with relevant facts and rationale to the USATKD Executive Director.
 - 1.6. The USATKD Executive Director shall determine what, if any, disciplinary action to impose based on the Extraordinary Sanctions Committee's report and recommendation. This decision shall be communicated to the subject of the report and announced to the public.
 - 1.7. Examples of sanctionable behaviors on the part of a contestant:
 - 1.7.1. Refusing to obey the referee's command to abide by the procedures of the match, including but not limited to refusing to bow to his/her opponent at the beginning of the match or not participating in the declaration of the winner at the end of the match
 - 1.7.2. Throwing his/her belongings (head protector, gloves, etc.) as an expression of dissatisfaction with decision
 - 1.7.3. Not leaving the competition area after the end of a match
 - 1.7.4. Not returning to a match after a referee's repeated command
 - 1.7.5. Not complying with the competition official's ruling or command
 - 1.7.6. Manipulation of scoring equipment, sensors or/and any part of a PSS
 - 1.7.7. Any serious unsportsmanlike behavior during a match or aggressive misconduct toward competition officials
 - 1.8. Examples of sanctionable behaviors on the part of a coach, official, or member of a Local Organizing Committee:
 - 1.8.1. Complaining about or arguing against an official's decision during or after a round
 - 1.8.2. Arguing with the referee or other official(s)

- 1.8.3. Violent behavior or remark toward officials, opponents or the opposing side, or spectators during a match
 - 1.8.4. Provoking spectators or spreading false rumor
 - 1.8.5. Violent behavior; e.g., throwing or kicking personal belongings or competition materials
 - 1.8.6. Instructing athlete(s) to participate in misconduct, such as remaining in the competition area after a match
 - 1.8.7. Not following instructions of competition officials to leave the field of play or venue
 - 1.8.8. Any other serious misconduct toward competition officials
 - 1.8.9. Any attempt to bribe competition officials
2. Disciplinary actions: Disciplinary Actions issued by the Extraordinary Sanctions Committee may vary according to the degree of the violation. The following sanctions may be given:
- 2.1. Disqualification of the athlete
 - 2.2. Warning and order to issue official apology
 - 2.3. Removal of accreditation
 - 2.4. Ban from the competition venue:
 - 2.4.1. Ban for the day
 - 2.4.2. Ban for the duration of the Championships
 - 2.5. Cancellation of Result
 - 2.5.1. Cancellation of the match result and all related merits
 - 2.5.2. Cancellation of USATKD ranking points
 - 2.6. Suspension of athlete, coach, or/and team officials from all USATKD activities:
 - 2.6.1. 6 month suspension
 - 2.6.2. 1 year suspension
 - 2.6.3. 2 year suspension
 - 2.6.4. 3 year suspension
 - 2.6.5. 4 year suspension
 - 2.7. Ban from from participating in USATKD Promoted or Sanctioned Championships:
 - 2.7.1. Specified championships
 - 2.7.2. All championships for a specified period of time (up to four (4) years)
 - 2.8. Monetary fine of between \$100-to-\$5,000 US dollars per violation.

3. The Extraordinary Sanctions Committee may recommend to USATKD that additional disciplinary action be taken against the person(s) involved, including but not limited to longer-term suspension, lifetime ban, and/or additional monetary fines.
4. Appeal of any disciplinary action(s) taken by Extraordinary Sanctions Committee may be made in accordance with Section 15 of USATKD Bylaws governing dispute resolution and disciplinary actions.

Article 25. Other Matters Not Specified in the Rules

1. Matters not specified in the Competition Rules shall be dealt with as follows:
 - 1.1. Matters related to the competition shall be decided through consensus by the refereeing officials of the pertinent contest, under the direction of the Ring Captain and if necessary, the Referee Chairman for the event.
 - 1.2. Matters which are not related to a specific contest shall be decided by the USATKD Executive Director or his/her designee.
 - 1.3. Matters and situations not covered by these competition rules will be resolved by precedents, interpretation, and the rules set forth by USATKD and WT.
 - 1.3.1. If the situation is covered by USATKD or WT rules, the Chairman of the Competition Supervisory Board will make final rulings.
 - 1.3.2. If the situation is not covered by USATKD or WT rules, the Executive Director of USATKD (or his/her appointed delegate) will make the final ruling after a joint meeting of the Competition Supervisory Board members and other committee members involved.

Official Letter of Protest

Event Name: _____ Date: _____

Division: _____ Gender: _____ Ring #: _____

Competitor Name: _____

I, _____, do hereby officially submit this protest in accordance with the Code of Operations of the _____ (event name) and Article XXX of the Kyorugi Competition Rules of USA Taekwondo.

Details of Protest:

Decision Delivered by the Competition Supervisory Board:

Name:	Signature:	Title:
_____	_____	_____
_____	_____	_____
_____	_____	_____
_____	_____	_____
_____	_____	_____

NOTE: Protest must be done within ten minutes after the match is complete. A non-refundable \$100 protest-filing fee, in cash, must be submitted along with this protest form. The decision of the Competition Supervisory Board is final, and there is no further recourse. You must sign this form with this understanding.

Coach Name (Print): _____

Coach Signature: _____