



Smith & Wesson®

Safety & Instruction Manual For



MODEL 1854



**Read the instructions and
warnings in this manual
CAREFULLY BEFORE
using this firearm.**

SMITH & WESSON®
1852 Proffitt Springs Rd.
Maryville, TN 37801

1-800-331-0852 • Fax: 1-413-747-3317

www.smith-wesson.com

Copyright 2023 Smith & Wesson Inc. All rights reserved.



WARNING:



**READ THESE INSTRUCTIONS
AND WARNINGS CAREFULLY.**

**BE SURE YOU UNDERSTAND THESE
INSTRUCTIONS AND WARNINGS BEFORE
USING THIS FIREARM. FAILURE TO READ
THESE INSTRUCTIONS AND TO FOLLOW
THESE WARNINGS MAY RESULT
IN SERIOUS INJURY OR DEATH TO
YOU AND OTHERS AND
DAMAGE TO PROPERTY.**

**THIS SAFETY & INSTRUCTION
MANUAL SHOULD ALWAYS ACCOMPANY
THIS FIREARM AND BE TRANSFERRED WITH
IT UPON CHANGE OF OWNERSHIP OR WHEN
PRESENTED TO ANOTHER PERSON.
A COPY OF THE SAFETY & INSTRUCTION
MANUAL IS AVAILABLE FREE
VIA DOWNLOAD AT
WWW.SMITH-WESSON.COM
OR UPON REQUEST FROM:**

**SMITH & WESSON®
CUSTOMER SUPPORT CENTER
1852 Proffitt Springs Rd.
Maryville, TN 37801**

**TEL.: 1-800-331-0852, ext. 4125
E-mail: qa@smith-wesson.com**

TABLE OF CONTENTS

YOUR SAFETY RESPONSIBILITIES	3-7
SAFE STORAGE AND TRANSPORTATION	7-9
AMMUNITION	9-12
MODEL & FEATURES IDENTIFICATION	13
FEATURES AND USER INTERACTION	14-15
HAMMER, TRIGGER, OPERATING LEVER, & CROSS-BOLT SAFETY FUNCTION	16-19
INSPECTING THE MODEL 1854	20-21
PREPARATION FOR FIRING	22-23
LOADING THE MODEL 1854	24-26
FIRING THE MODEL 1854	27-28
HANGFIRES AND MISFIRES	29-30
CLEARING A MISFEED/JAM	30-31
UNLOADING THE MODEL 1854	31-33
DISASSEMBLY/FIELD STRIPPING	34-36
ASSEMBLY	37-39
OFFSET HAMMER SPUR EXTENSION	40
M-LOK® FOREND SLOTS (if so-equipped)	41
INSTALLATION OF SIGHTS/OPTICS	42
REAR SIGHT ADJUSTMENT	43
CLEANING AND MAINTENANCE	43-46
LIMITED WARRANTY-For Owners Within United States	47-48
CONTACT & SHIPPING INFORMATION-For Owners Within United States ..	49-50
BATTERY WARNINGS	51
PATENT INFORMATION, CUSTOM SERVICE	52

YOUR SAFETY RESPONSIBILITIES

SAFETY IS YOUR NUMBER ONE RESPONSIBILITY!

- At home, in the field, at the range, or anywhere, the first concern of every firearm owner should be safety. Apply the following safety rules in every situation, with any kind of firearm. If you feel uncertain about any operational aspects of your firearm, please contact Smith & Wesson® at 1-800-331-0852, ext. 4125 before proceeding with its operation.
- If you are unfamiliar with firearms you should seek formal training before using your firearm.



WARNING: YOU MUST FOLLOW ALL OF THESE SAFETY RULES TO ENSURE THE SAFE USE OF YOUR FIREARM. THE FAILURE TO FOLLOW THE INSTRUCTIONS AND WARNINGS IN THIS MANUAL COULD CAUSE PERSONAL INJURY OR DEATH TO YOU OR OTHERS AND DAMAGE TO PROPERTY.

- As a firearm owner, you accept a demanding responsibility. How seriously you take this responsibility can be the difference between life and death. There is no excuse for careless or abusive handling of your firearm. At all times, handle your firearm with intense respect for its power and potential danger.



YOUR SAFETY RESPONSIBILITIES - CONTINUED

- **ALWAYS KEEP THE MUZZLE OF THE FIREARM POINTED IN A SAFE DIRECTION.** Never point a firearm at anyone or anything you do not intend to shoot whether or not it is loaded. This is particularly important when loading, unloading, or field stripping the firearm. ALWAYS control the direction of the firearm.
- **ALWAYS TREAT EVERY FIREARM AS IF IT IS LOADED AND WILL FIRE.** Do not take anyone's word that the firearm is unloaded – always check for yourself. Never pass your firearm to another person until the cylinder or action is open and you visually check that it is unloaded. Keep your firearm unloaded and safely stored when not in use.
- **NEVER PLACE YOUR FINGER INSIDE THE TRIGGER GUARD OR ON THE TRIGGER UNLESS YOU INTEND TO FIRE.** Ensure that other objects do not touch the trigger.
- **ALWAYS BE SURE OF YOUR TARGET AND WHAT IS BEYOND IT.** Always be sure of where the bullet will strike and shoot only where there is a safe back stop free of obstructions, water or other surfaces which can cause a ricochet. Be sure your bullet will stop behind your target. Bullets can glance off many surfaces like rocks or the surface of water and travel in unpredictable directions with considerable velocity. Do not fire randomly into the sky.
- **NEVER CROSS OBSTACLES SUCH AS FENCES OR STREAMS WITH A LOADED FIREARM.** Always make certain your firearm is unloaded before crossing a fence, climbing a tree, jumping a ditch or negotiating other obstacles.
- **NEVER CLIMB INTO OR OUT OF A TREE OR TREE STAND WITH A LOADED FIREARM.**
- **NEVER RAISE OR LOWER A LOADED FIREARM FROM A TREE OR TREE STAND.** Hunting from elevated points such as a tree stand is dangerous. Always ensure that the "stand" being used is stable and secure before ascending. Make certain that your firearm is unloaded when it is being taken into and down from the "stand". Make certain that your firearm is not dropped from the stand, or dropped while it is being taken up or down from the "stand" as damage to the firearm's mechanism may result.
- **SAFE FIREARM HANDLING IS YOUR PERSONAL RESPONSIBILITY AT ALL TIMES.** Firearms are dangerous and can cause injury or death if they are misused or used inappropriately. Safety must be the prime consideration of any one who owns or handles firearms. Accidents are the result of violating the rules of safe firearm handling and common sense. Firearm safety training is available. Contact your firearms dealer, law enforcement agency, local sportsman's club, etc. for availability.

YOUR SAFETY RESPONSIBILITIES - CONTINUED

- **YOU ARE RESPONSIBLE FOR THE FIREARM AT ALL TIMES.** In owning a firearm, you must undertake full-time responsibility for your firearm's safety and security. You must protect yourself and all others against injury or death from misuse of the firearm 24 hours a day.
- **FIREARM SECURITY IS YOUR RESPONSIBILITY.** You must secure firearms safely from children and/or unauthorized users. Your firearm should always be kept unloaded and locked when not in use. A lock has been provided for this purpose. Never assume that the use of this lock is sufficient to safely secure your firearm. You must always evaluate your personal situation and employ the security systems that meet your needs to prevent children and unauthorized users from gaining access to your firearm.
- **APPROPRIATE USE FOR YOUR FIREARM MEANS USING YOUR FIREARM FOR LEGAL PURPOSES.** For example - target shooting, hunting and lawful resistance of deadly criminal force. It is your responsibility to ensure that you are in compliance with all applicable laws and ordinances regarding the use of your firearm.
- **NEVER RELY ON MECHANICAL FEATURES ALONE.** Only your safe firearm-handling habits will ensure the safe use of your firearm. This is your responsibility.
- **ALWAYS SAFELY STORE AND SECURE YOUR FIREARM.** Safe and secure storage of your firearm is one of your most important responsibilities. It is a full-time responsibility. You must always secure your firearm and ammunition separately so that they are not accessible to children and/or other unauthorized persons.
- **NEVER KEEP AMMUNITION IN THE SAME LOCATION AS THE FIREARM.** Store each in a separate and secure place.
- **ALWAYS WEAR EYE PROTECTION THAT IS SPECIFIED FOR USE WITH FIREARMS EVERY TIME YOU HANDLE YOUR FIREARM FOR CLEANING AND MAINTENANCE.**
- **ALWAYS WEAR EYE AND HEARING PROTECTION THAT ARE SPECIFIED FOR USE WITH FIREARMS EVERY TIME YOU DISCHARGE YOUR FIREARM.** Make sure others in the vicinity of where you will be shooting do so as well.
- **NEVER USE ALCOHOL OR DRUGS BEFORE OR WHILE SHOOTING.** Do not use your firearm if you are on any medication which impairs, even slightly, your mental or physical ability.
- **ALWAYS HAVE ADEQUATE VENTILATION.** Discharging firearms in poorly ventilated areas, cleaning firearms, or handling ammunition may result in exposure to lead and other substances known to cause birth defects, reproductive harm, and other physical injury. Review the warnings and labels for all ammunition and cleaning products carefully. Wash hands thoroughly after exposure.



YOUR SAFETY RESPONSIBILITIES - CONTINUED

- **BEFORE HANDLING ANY FIREARM, UNDERSTAND ITS OPERATION.** Not all firearms are the same. Familiarize yourself with the mechanical features of any firearm you intend to use. If you feel uncertain about any operational aspects of your firearm, please contact Smith & Wesson® at 1-800-331-0852, ext. 4125 before proceeding with its operation.
- **NEVER ALLOW A FIREARM TO BE USED BY ANY INDIVIDUAL WHO DOES NOT UNDERSTAND ITS SAFE OPERATION OR HAS NOT READ THIS SAFETY AND INSTRUCTION MANUAL.**
- **ALWAYS USE THE CORRECT AMMUNITION FOR YOUR PARTICULAR FIREARM AS INDICATED BY THE MARKING ON THE FIREARM.** Never use non-standard, reloaded, or “handloaded” ammunition which has not been subjected to internal ballistic pressure testing.
- **BEWARE OF BARREL BORE OBSTRUCTIONS.** Be sure the barrel bore is clear of obstructions before shooting. Mud, water, snow, or other objects may inadvertently lodge in the barrel bore. A small obstruction can cause a dangerous increase in pressure and cause injury to yourself and others and may damage your gun.
- **BE SURE ALL SLINGS, ADD-ONS, AND ACCESSORIES ARE COMPATIBLE WITH THE FIREARM AND THAT THE ACCESSORIES DO NOT INTERFERE WITH SAFE OPERATION.** It is your responsibility to understand and follow all of the instructions in this manual, as well as those which may be supplied with your ammunition and any accessory.
- **NEVER DISASSEMBLE YOUR FIREARM BEYOND THE DISASSEMBLY/FIELD STRIPPING PROCEDURE DETAILED IN THIS MANUAL, OR PERFORM ANY MAINTENANCE, ADJUSTMENT, OR SERVICE NOT SPECIFIED.** Improper disassembly and reassembly of your firearm may lead to injury or death of the shooter and/or bystanders and damage to property.
- **NEVER MODIFY OR SWAP OUT ANY OF THE COMPONENTS OF YOUR SMITH & WESSON FIREARM, UNLESS SPECIFICALLY INSTRUCTED TO DO SO IN THIS MANUAL OR IN AN OFFICIAL SMITH & WESSON ACCESSORY PARTS MANUAL OR INSTRUCTION SHEET. CHANGES NOT COVERED IN THIS MANUAL OR IN A SMITH & WESSON INSTRUCTION SHEET WILL REQUIRE A QUALIFIED GUNSMITH (OR FACTORY-TRAINED PERSONNEL) USING FACTORY-AUTHORIZED PARTS.** Improper manipulation of any component of the firearm may result in faulty functioning, possibly leading to injury or death of the shooter and/or bystanders and damage to property.

YOUR SAFETY RESPONSIBILITIES - CONTINUED



WARNING: SAFE USE OF A FIREARM IS YOUR PERSONAL RESPONSIBILITY AND THE FAILURE TO FOLLOW ALL OF THESE BASIC SAFETY RULES MAY RESULT IN SEVERE PERSONAL INJURY OR DEATH TO YOU OR OTHERS AND DAMAGE TO PROPERTY. YOU ARE THE MOST IMPORTANT SAFETY DEVICE WHEN IT COMES TO THE USE OF YOUR FIREARM AND SMITH & WESSON® WILL NOT BE RESPONSIBLE FOR ANY PERSONAL INJURY, DEATH OR PROPERTY DAMAGE THAT RESULTS FROM: (1) THE CRIMINAL OR NEGLIGENT USE OF THIS FIREARM; (2) A DISREGARD OF THESE SAFETY INSTRUCTIONS AND WARNINGS; (3) IMPROPER OR CARELESS HANDLING OF THIS FIREARM; (4) THE USE OF NON-STANDARD, DEFECTIVE OR IMPROPER AMMUNITION; OR (5) IMPROPER OR NEGLIGENT MODIFICATIONS OR REPAIRS TO THE FIREARM.

SAFE STORAGE AND TRANSPORTATION



WARNING: ALWAYS KEEP THE MUZZLE OF THE FIREARM POINTED IN A SAFE DIRECTION.



WARNING: FIREARMS ARE DANGEROUS WHEN USED AND STORED IMPROPERLY. THEY POSE A RISK OF SERIOUS OR FATAL INJURIES. FIREARMS CAN BE ESPECIALLY DANGEROUS TO CHILDREN WHEN THEY ARE STORED IN AN IRRESPONSIBLE AND UNSAFE MANNER. FOR YOUR SAFETY AND THE SAFETY OF OTHERS, IT IS IMPERATIVE THAT YOU KEEP YOUR FIREARM LOCKED AND UNLOADED IN A SECURE PLACE. THE AMMUNITION SHOULD BE STORED IN A SEPARATE, SECURE LOCATION WHEN IT IS NOT IN USE. SAFE AND SECURE STORAGE OF YOUR FIREARM IS ONE OF THE MOST IMPORTANT RULES OF FIREARM SAFETY. YOUR FAILURE TO FOLLOW THESE RULES MAY RESULT IN INJURY OR DEATH TO YOU OR OTHERS.

- **ALWAYS SECURE YOUR FIREARM IN A MANNER THAT WILL PREVENT UNAUTHORIZED ACCESS.** Whenever your firearm is not in use, keep it unloaded and locked. Your safety and the safety of others requires that you always secure and store your firearm in a manner that will prevent unauthorized access. Never leave a firearm unattended unless it is locked, unloaded and secured.

SAFE STORAGE AND TRANSPORTATION - CONTINUED

- **ALWAYS USE THE LOCK PROVIDED BY SMITH & WESSON® TO SECURE YOUR FIREARM.** Please read and follow the instructions packaged separately for the use of this lock. A lock, when properly used, can be an effective tool in preventing unauthorized access to your firearm. There are other alternative locks and safe storage containers available in the marketplace which may also be appropriate for your particular needs. Consult your local firearm shop, hardware store, or local police department for guidance on the variety of other safe storage devices or practices which may be appropriate for your particular needs. By purchasing this firearm you have accepted the responsibility of safely securing the firearm at all times and preventing its unauthorized use. Never assume that the use of this lock alone is sufficient to safely secure your firearm. It is your personal responsibility to select and use whatever measures or practices that will enable you to be absolutely certain that your firearm is secure at all times.



WARNING: NEVER LOCK A LOADED FIREARM AND NEVER LOAD A LOCKED FIREARM!

- **ALWAYS STORE YOUR FIREARM AND AMMUNITION SEPARATELY SO THAT THEY ARE NOT ACCESSIBLE TO CHILDREN OR OTHER UNAUTHORIZED PERSONS.** Safe and secure storage of your firearm and ammunition are your responsibility. It is a full-time responsibility.
- **NEVER ASSUME THAT A "HIDING" PLACE IS A SECURE STORAGE METHOD.** Others may be aware of your storage location or come upon it by chance. It is your personal responsibility to use common sense when storing your firearm and ammunition and to always make sure they are not accessible to children or other unauthorized persons.
- **NEVER TRANSPORT A LOADED FIREARM.** When transporting your firearm, be sure it is unloaded and locked. Safe and secure transportation of your firearm is your responsibility.
- **ALWAYS FOLLOW THE LAW!** Many jurisdictions have laws that make it a crime to keep a firearm unlocked and in an area accessible to children or others. Keeping a firearm locked and unloaded when not in use is not only common sense safety practice... **IT IS THE LAW.** You must be familiar with all local, state, and federal laws regarding the safe storage and transportation of your firearm. Failure to know and follow the law may result in unauthorized access or use of your firearm by another. Obey all laws relating to the storage and transportation of firearms. Your local police department or firearm shop can furnish you with available information on storing and/or transporting a firearm safely and legally.

SAFE STORAGE AND TRANSPORTATION - CONTINUED

- **YOUR FIREARM IS YOUR RESPONSIBILITY.** You must prevent your firearm from being stolen or from being used by untrained or unqualified individuals. Keep it locked, unloaded and secured when not in use.
- Never leave the key to the gun lock with the stored firearm.

AMMUNITION

WARNING: NEVER USE AMMUNITION NOT SPECIFICALLY DESIGNATED FOR USE IN YOUR FIREARM. FAILURE TO USE THE CORRECT TYPE OR CALIBER OF AMMUNITION MAY CAUSE THE FIREARM TO JAM, FAIL TO FIRE, OR MAY GENERATE EXCESSIVE PRESSURE WHICH CAN DAMAGE OR EVEN RUPTURE YOUR FIREARM, CAUSING PERSONAL INJURY OR DEATH TO THE SHOOTER OR BYSTANDERS.

- Locate the cartridge designation marked on the rifle's barrel. This information indicates the correct ammunition that must be used in your firearm (FIGURE 1).
- You are responsible for selecting ammunition that meets industry standards and is appropriate in type and caliber for this firearm.

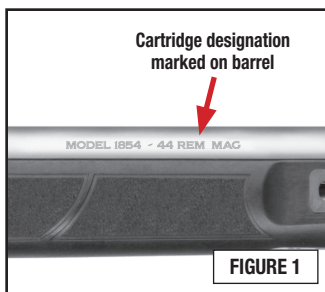

- Never mix ammunition.

WARNING: IN SOME CASES AMMUNITION NOT SPECIFIED ON YOUR FIREARM AND NOT LISTED AS ALTERNATE AMMUNITION IN THIS MANUAL MAY FIT INTO THE CHAMBER. FIRING THIS AMMUNITION MAY CAUSE A RUPTURE, RESULTING IN PERSONAL INJURY OR DEATH TO THE SHOOTER AND/OR BYSTANDERS AND DAMAGE TO PROPERTY.

FOR MORE INFORMATION REGARDING GENERALLY ACCEPTED FIREARMS AND AMMUNITION INTERCHANGEABILITY, AS PUBLISHED BY SPORTING ARMS AND AMMUNITION MANUFACTURERS' INSTITUTE (SAAMI), FIND IT AT [HTTPS://SAAMI.ORG](https://saami.org)

- Different combinations of bullet velocity, bullet weight and firearm weight can have major impact on felt recoil; high felt recoil can be uncomfortable to some shooters.

AMMUNITION - CONTINUED



WARNING: ALWAYS INSPECT YOUR AMMUNITION BEFORE USING IT. NEVER USE DIRTY, CORRODED OR DAMAGED AMMUNITION. A BURST CARTRIDGE OR BORE OBSTRUCTION MAY RESULT CAUSING DAMAGE TO THE FIREARM AND PERSONAL INJURY OR DEATH TO THE SHOOTER AND/OR BYSTANDERS.



WARNING: NEVER USE AMMUNITION OF THE INCORRECT GAUGE OR CALIBER. USING AMMUNITION OF THE INCORRECT GAUGE OR CALIBER MAY CAUSE DAMAGE TO YOUR FIREARM AND POSSIBLE INJURY TO YOU AND TO OTHERS.



WARNING: DISCHARGING FIREARMS IN POORLY VENTILATED AREAS, CLEANING FIREARMS, OR HANDLING AMMUNITION MAY RESULT IN EXPOSURE TO LEAD AND OTHER SUBSTANCES KNOWN TO CAUSE BIRTH DEFECTS, REPRODUCTIVE HARM AND OTHER PHYSICAL INJURY. HAVE ADEQUATE VENTILATION AT ALL TIMES. WASH HANDS THOROUGHLY AFTER EXPOSURE.



WARNING: NEVER USE NON-STANDARD, RELOADED OR "HANDLOADED" AMMUNITION WHICH HAS NOT BEEN SUBJECTED TO INTERNAL BALLISTIC PRESSURE TESTING. RELOADED OR HANDLOADED AMMUNITION MAY HAVE MANY MANUFACTURING AND QUALITY VARIABLES (SUCH AS THE TYPE AND AMOUNT OF GUN POWDER). CARTRIDGE CASES THAT HAVE BEEN RELOADED AND FIRED MULTIPLE TIMES MAY SUFFER PHYSICAL DAMAGE WHICH COULD SIGNIFICANTLY IMPACT OR REDUCE THE INTEGRITY OF THE CARTRIDGE, POSSIBLY RESULTING IN BULLET SETBACK OR UNSEATING. CASE FAILURE AND INJURY TO THE SHOOTER OR BYSTANDERS AND DAMAGE TO THE FIREARM MAY RESULT WHEN SUCH A CARTRIDGE IS FIRED. ANY AMMUNITION THAT IS IMPROPERLY MANUFACTURED OR RELOADED, EVEN IN THE SLIGHTEST DEGREE, MAY FAIL TO FIRE OR MAY GENERATE EXCESSIVE INTERNAL PRESSURES WHICH CAN DAMAGE OR EVEN RUPTURE THE FIREARM, CAUSING PERSONAL INJURY OR DEATH TO THE SHOOTER OR THOSE IN THE IMMEDIATE VICINITY.



WARNING: NEVER USE CARTRIDGES OTHER THAN THOSE DESIGNATED BY THE MARKING ON THE FIREARM UNLESS SPECIFIED IN THIS MANUAL. DOING SO MAY CAUSE INJURY OR DEATH TO THE SHOOTER OR BYSTANDERS AND DAMAGE TO PROPERTY.

AMMUNITION - CONTINUED



WARNING: NEVER APPLY LUBRICANTS OR CLEANER DIRECTLY ONTO AMMUNITION. APPLYING LUBRICANT OR CLEANER TO AMMUNITION CAN CONTAMINATE THE AMMUNITION AND RESULT IN A SQUIB LOAD. A SQUIB LOAD CAN RESULT IN A BORE OBSTRUCTION WHEN THE BULLET BECOMES LODGED IN THE BORE. INJURY OR DEATH TO THE SHOOTER OR BYSTANDERS AND DAMAGE TO PROPERTY COULD RESULT WHEN A SUBSEQUENT CARTRIDGE IS FIRED.

- A firearm and ammunition are a system and must work together. There are different types of ammunition for different types of firearms. Your firearm has been designed for ammunition of a specific type and a specific gauge or caliber. It is important to select the proper ammunition for your firearm.

Marking on Firearm	Ammunition Type		
	Standard	+P	+P+
357 Magnum	OK	NO	NO
44 Rem Mag	OK	NO	NO
45 Colt	OK	NO	NO

- “Plus-P” (+P) ammunition generates pressures in excess of the pressures associated with standard ammunition. Such pressures may affect the wear characteristics and may result in the need for more frequent service.
- “Plus-P-Plus” (+P+) ammunition must NOT be used in Smith & Wesson® firearms. This marking on the ammunition designates that it exceeds established industry standards, but the designation does not represent defined pressure limits and therefore such ammunition may vary significantly as to the pressures generated and could be DANGEROUS.



WARNING: SOME POINTED AND FULL METAL JACKET ROUND NOSE BULLETS CAN CAUSE A CHAIN-FIRE OF THE OTHER CARTRIDGES IN THE MAGAZINE TUBE DURING RECOIL OR FROM DROPPING THE RIFLE, CAUSING INJURY, DEATH AND PROPERTY DAMAGE. IF YOU ARE UNCERTAIN ABOUT THE SAFETY OF USING A PARTICULAR CARTRIDGE OR BULLET IN YOUR RIFLE, CONTACT THE AMMUNITION OR BULLET MANUFACTURER TO VERIFY THAT IT IS OKAY.

AMMUNITION - CONTINUED

- The MODEL 1854 chambered for 357 Magnum is designed to function correctly with most standard factory-loaded 357 Magnum ammunition (exceptions may include wad cutters, shotshells and some extra-heavy bullets). It will also function with most 38 Special cartridges.

CLEANING CHAMBER NOTE: 38 Special cartridge cases are shorter than 357 Magnum cases. Use of 38 Special ammunition in this rifle can cause a buildup at the front of the chamber. Thoroughly clean the chamber area with a brush and gun-cleaning solvent after using 38 Special ammunition to avoid extraction issues when next firing 357 Magnum.

- The MODEL 1854 chambered for 44 Remington Magnum is designed to function correctly with most standard factory-loaded 44 Rem. Magnum ammunition (exceptions may include wad cutters, shotshells and some extra-heavy bullets). It will also function with most 44 Special cartridges.

CLEANING CHAMBER NOTE: 44 Special cartridge cases are shorter than 44 Rem. Magnum cases. Use of 44 Special ammunition in this rifle can cause a buildup at the front of the chamber. Thoroughly clean the chamber area with a brush and gun-cleaning solvent after using 44 Special ammunition to avoid extraction issues when next firing 44 Rem. Magnum.

Marking on Firearm	Can Also Fire
44 Rem Mag	44 SPECIAL
357 Magnum	38 S&W Special and 38 S&W Special +P

MODEL & FEATURES IDENTIFICATION

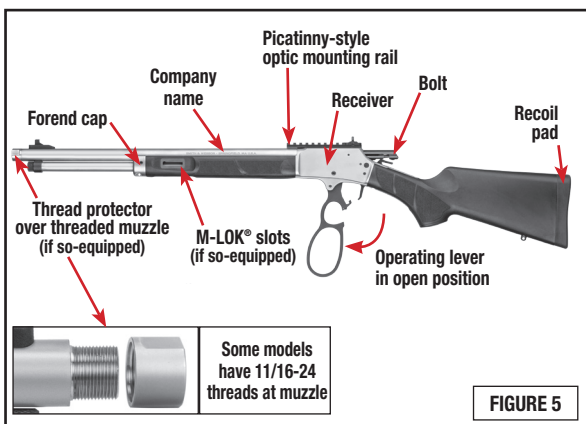
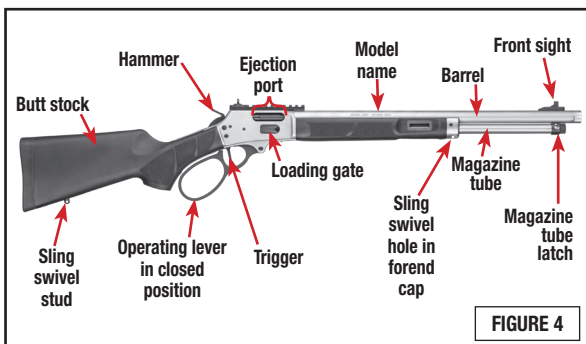
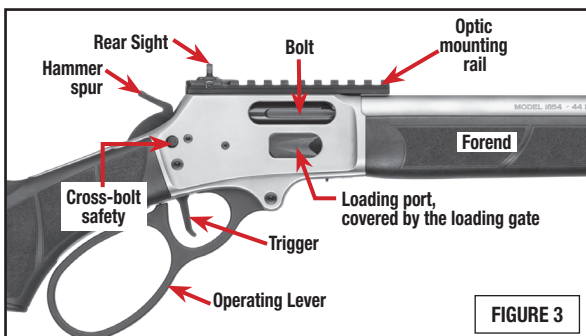
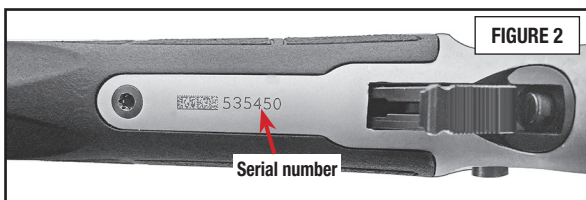

- Read all sections of this manual to familiarize yourself with the unique features of this firearm and how they interact.

FEATURES AND USER INTERACTION

- The elevator (FIGURE 6) is visible when the bolt is open. The elevator raises a cartridge to align with the chamber when the operating lever is pulled closed.

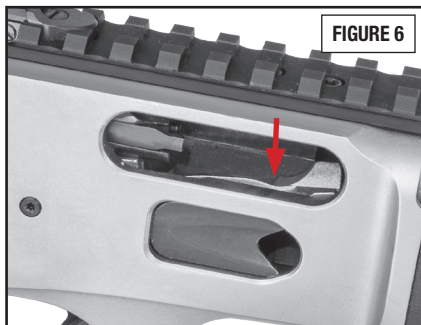

FIGURE 6

- The magazine tube is mounted under the barrel and is retained by a friction-fit latch. The tube is unlatched by turning it counterclockwise (FIGURES 7 & 8). Withdraw the magazine tube to unload.

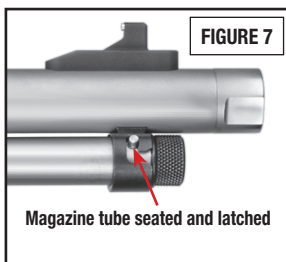

FIGURE 7

Magazine tube seated and latched

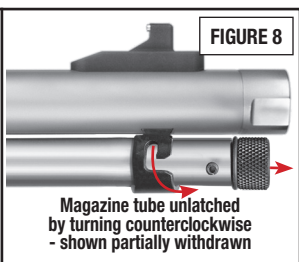

FIGURE 8

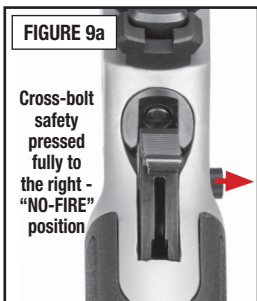

FIGURE 9a

Cross-bolt safety pressed fully to the right - "NO-FIRE" position

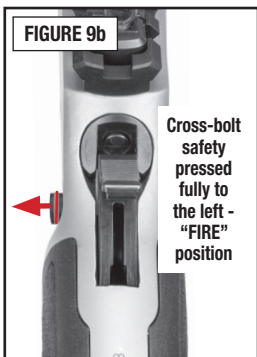

FIGURE 9b

Cross-bolt safety pressed fully to the left - "FIRE" position

CROSS-BOLT SAFETY NOTE: The cross-bolt safety (FIGURES 9a and 9b) can only be moved if the hammer is in either the half-cock or cocked position. The cross-bolt safety cannot be moved if the hammer is in the full forward position resting against the bolt or when half-cock is bypassed while lowering the hammer from the cocked position. The cross-bolt safety should be fully to the right in the "NO-FIRE" position except when the user is in the act of firing.

LOWERING HAMMER NOTE: It may be necessary for the user to lower the hammer from the cocked position. Be certain to keep the rifle pointed in a safe direction and always control the movement of the cross-bolt safety, the hammer and the trigger during these moments (FIGURE 10).

FEATURES AND USER INTERACTION - CONTINUED

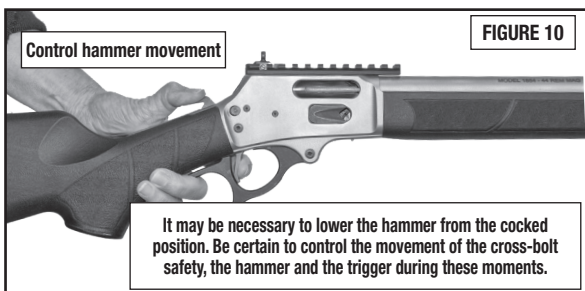

Smith & Wesson® recommends practicing with an unloaded rifle until you are confident you can manipulate the operating lever and move the cross-bolt safety to the desired position, cock the hammer and place the hammer in the half-cock position as called for.

BRISK CYCLING NOTE: Smith & Wesson recommends that the user work the operating lever briskly during normal use. Cycling the lever slowly tends to increase the chances of encountering a failure to feed a round into the chamber smoothly and a failure to eject (FIGURE 11).

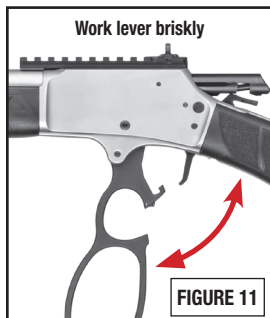

SHORT-STROKING NOTE: “Short-stroking” the operating lever (failure to move it fully from closed to fully open and then back to fully closed) may cause failures to eject a cartridge or empty case and could inadvertently rechamber a live cartridge or spent case (FIGURE 12). Move the operating lever fully through its range of travel when cycling to ensure proper function.

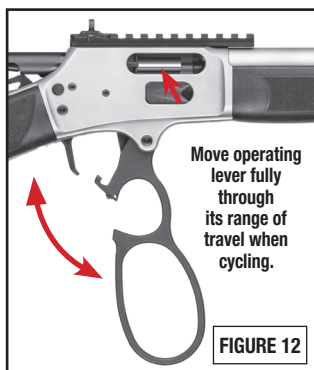

DRY-FIRING NOTE: Smith & Wesson recommends dry-firing the MODEL 1854 rifle only with the rifle empty and the cross-bolt safety pressed fully to the right “NO-FIRE” position.

RIFLE CONTROLS NOTE: The MODEL 1854 lever-action rifle is equipped with an external hammer, a cross-bolt safety, a trigger, and an operating lever. The interaction of these parts must be understood before loading and firing the rifle.

HAMMER, TRIGGER, OPERATING LEVER, & CROSS-BOLT SAFETY FUNCTION



ALWAYS KEEP THE MUZZLE OF THE FIREARM POINTED IN A SAFE DIRECTION.



WARNING: NEVER CARRY, HANDLE OR TRANSPORT THE MODEL 1854 RIFLE WITH A CARTRIDGE IN THE CHAMBER AND THE HAMMER RESTING ON THE REAR OF THE BOLT WHERE THE FIRING PIN IS LOCATED.



WARNING: DECOCK THE RIFLE ONLY WHEN THE CROSS-BOLT SAFETY IS IN THE “NO-FIRE” POSITION.

The Hammer Can Be Found in Various Positions:

Cocked (FIGURE 13) - Hammer is held fully rearward after cycling the action or by manually drawing the hammer back. Cross-bolt safety can be moved in either direction (to the “FIRE” or “NO-FIRE” position) with hammer cocked.

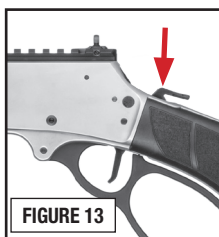

Half-cock (FIGURE 14) - The sear is resting against the half-cock notch of the hammer, allowing the cross-bolt safety to be moved from side-to-side (to the “FIRE” or “NO-FIRE” position).

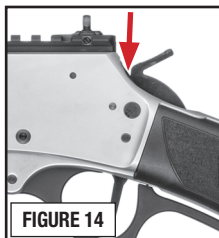

Resting against the cross-bolt safety (FIGURE 15) - If half-cock is bypassed during “uncocking” the hammer, it will come to rest against the cross-bolt safety, preventing the safety’s movement.

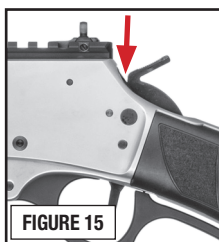

Fired (FIGURE 16) - Hammer fully forward against the rear of the bolt, once the cross-bolt safety has been placed in the FIRE position and the trigger is pulled. This can happen either upon firing (dry firing with no cartridge in the chamber or live firing with a cartridge in the chamber) or upon lowering the hammer to this position by holding the hammer spur, pulling the trigger and lowering the hammer fully forward.

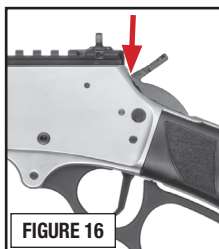

HAMMER, TRIGGER, OPERATING LEVER, & CROSS-BOLT SAFETY FUNCTION - CONTINUED

The Trigger of the MODEL 1854:

TRIGGER NOTE: The trigger assembly in the MODEL 1854 is factory set for optimal trigger pull. The trigger is not adjustable and should not be modified.

- While observing safe gun-handling practices, the trigger is pulled fully to the rear by the user to fire the rifle, after these steps:
 - 1) The chamber is loaded with the correct ammunition.
 - 2) The lever is fully closed.
 - 3) The hammer has been cocked.
 - 4) The cross-bolt safety is pushed fully left to the "FIRE" position.
- To decock the rifle from the cocked position (FIGURE 17):
 - 1) The cross-bolt safety must be in the "NO-FIRE" position.
 - 2) Hold hammer spur firmly with your thumb to control movement.
 - 3) The trigger is pulled and then released immediately.
 - 4) The hammer is manually lowered to the half-cock position.

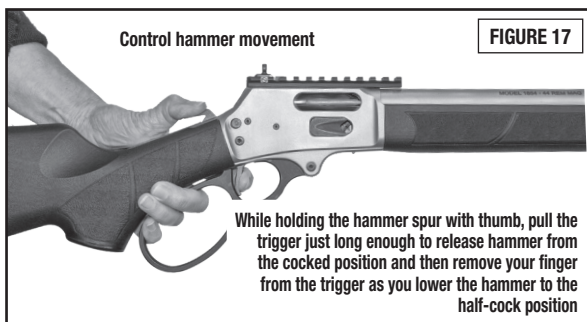

- The trigger is blocked from movement rearward until the operating lever is fully closed (FIGURES 18 AND 19) and the trigger block is disengaged.

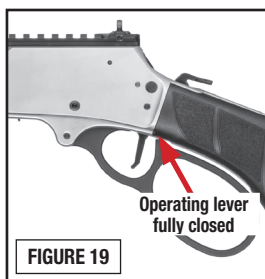
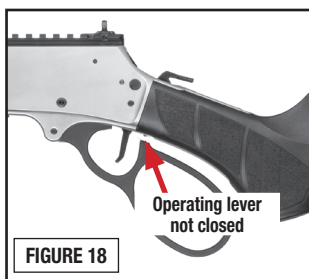

HAMMER, TRIGGER, OPERATING LEVER, & CROSS-BOLT SAFETY FUNCTION - CONTINUED

The Cross-bolt Safety:

“NO-FIRE” Position (FIGURE 20) - Cross-bolt safety is pushed fully to the right (as viewed from above or from the rear) with hammer in either half-cock or cocked position.

“FIRE” Position - (FIGURE 21) - Cross-bolt safety is moved fully to the left (as viewed from above or from the rear), hammer is in half-cock or cocked position. The red line on the cross-bolt safety is visible.

CROSS-BOLT SAFETY NOTE: The cross-bolt safety can be moved only if the hammer is in either the half-cock or cocked position.

The cross-bolt safety cannot be moved if the hammer is in the full forward “FIRED” position resting against the bolt or when the half-cock position has been bypassed during lowering the hammer from the cocked position.

Return the hammer to the half-cock position to allow the cross-bolt safety to be moved.



HAMMER, TRIGGER, OPERATING LEVER, & CROSS-BOLT SAFETY FUNCTION - CONTINUED

The Operating Lever:

1) Fully Open (FIGURE 22) - The operating lever is pressed/pulled fully down and forward until it stops, this opens the bolt, extracting and ejecting any cartridge that was chambered and it cocks the hammer. Cross-bolt safety can be moved.

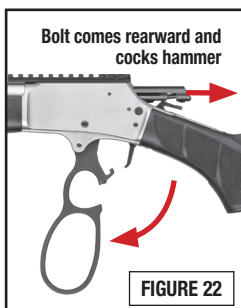

2) Partially Open (FIGURE 23) - The operating lever somewhere between fully open and fully closed. Closing will potentially load any cartridge that was present in the magazine tube or action into the chamber. Opening will partially extract any chambered round or cartridge case. Trigger block is engaged until operating lever is “clicked” into fully closed position.

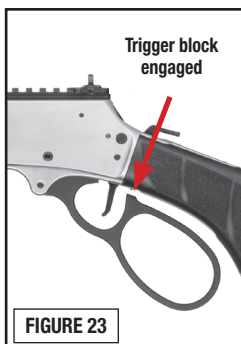

3) Fully Closed (FIGURE 24) - The operating lever pulled fully up and “clicked” into position. Trigger block disengaged. Cross-bolt safety movement is dependant on position of hammer - see cross-bolt safety criteria on page 18.

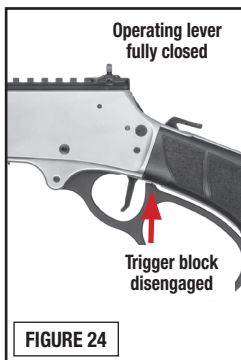

BRISK CYCLING NOTE: Smith & Wesson® recommends that the user work the operating lever briskly during normal use. Cycling the lever slowly tends to increase the chances of encountering a failure to feed a round into the chamber smoothly and a failure to eject.

INSPECTING THE MODEL 1854



ALWAYS KEEP THE MUZZLE OF THE FIREARM POINTED IN A SAFE DIRECTION.



WARNING: ENSURE THAT THE FIREARM IS UNLOADED AND THE CROSS-BOLT SAFETY IS IN THE NO-FIRE POSITION BEFORE INSPECTING, DISASSEMBLING, ASSEMBLING, CLEANING, ADDING OR REMOVING ACCESSORIES AND LOADING.



WARNING: NEVER RELY ON MECHANICAL FEATURES ALONE. ONLY YOUR SAFE FIREARM HANDLING WILL ENSURE THE SAFE USE OF YOUR FIREARM. THIS IS YOUR RESPONSIBILITY.



WARNING: BE CAREFUL WHEN OPERATING THE MECHANISM OF THE MODEL 1854 LEVER-ACTION TO AVOID PINCH POINTS.

- As shipped from the factory, the MODEL 1854 rifle has an empty chamber flag in place (FIGURE 25).
- Grasp the operating lever and pull/push it down and fully forward until it stops.
- Remove the empty chamber flag from the firearm if one is present (FIGURE 26).
- Verify that the chamber, receiver and magazine tube are empty (FIGURE 27).

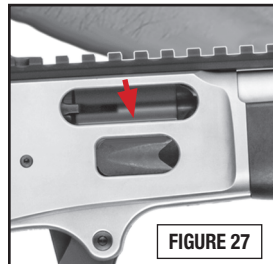
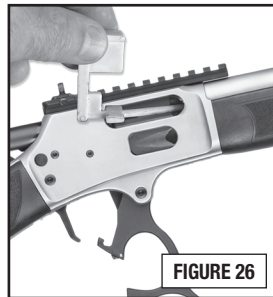
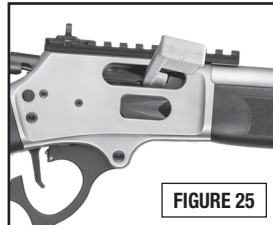

INSPECTING THE MODEL 1854 - CONTINUED

- With the action open, press the cross-bolt safety fully to the right into the “NO FIRE” position (as viewed from above or from the rear) (FIGURE 28).
- Look into the ejection port, ensure the firing pin is NOT protruding from the bolt face (FIGURE 29).



WARNING: VERIFY THAT THE FIRING PIN IS NOT PROTRUDING FROM THE BOLT FACE. IF THE FIRING PIN IS PROTRUDING, MAKE SURE THE FIREARM IS POINTED IN A SAFE DIRECTION, UNLOAD THE FIREARM (SEE PAGE 31) AND HAVE IT INSPECTED AND TEST FIRED BY A GUNSMITH QUALIFIED TO PERFORM SERVICE ON SMITH & WESSON® FIREARMS.



- You must follow this procedure every time a firearm leaves your hand, is cleaned, handed to you or another person, transported or stored.
- Before using this firearm for the first time, it should be cleaned. See the “*Cleaning and Maintenance*” section of this manual (page 43) for details.

PREPARATION FOR FIRING



WARNING: ALWAYS KEEP THE MUZZLE OF THE FIREARM POINTED IN A SAFE DIRECTION.



WARNING: FAILURE TO FOLLOW THESE FIREARM SAFETY REQUIREMENTS MAY RESULT IN INJURY OR DEATH TO YOU OR OTHERS AND DAMAGE TO PROPERTY.





WARNING: NEVER CARRY OR HANDLE THE MODEL 1854 RIFLE WITH A CARTRIDGE IN THE CHAMBER AND THE HAMMER RESTING ON THE REAR OF THE BOLT WHERE THE FIRING PIN IS LOCATED.

- **ALWAYS TREAT ALL FIREARMS AS IF THEY ARE LOADED.**
- **ALWAYS BE SURE THAT THE CHAMBER, RECEIVER AND MAGAZINE ARE EMPTY.**
- **ALWAYS BE SURE THAT THE BORE IS CLEAR AND THAT THERE IS NO OBSTRUCTION PRESENT IN THE BORE PRIOR TO LOADING AND FIRING.**
- **ALWAYS KEEP FINGERS AND OTHER BODY PARTS AWAY FROM THE MUZZLE AND AWAY FROM THE EJECTION PORT.**
- **ALWAYS WEAR ADEQUATE AND PROPER HEARING PROTECTION SPECIFIED FOR FIREARM USE.** To prevent permanent damage to your hearing, you must always use hearing protection. Make sure others who are nearby are wearing hearing protection as well.
- **ALWAYS WEAR SAFETY GLASSES SPECIFIED FOR FIREARM USE.** Whether indoors or out, safety glasses should protect your eyes from the firing flash and particles associated with the discharge of ammunition. Failure to do so creates a risk of personal injury from particle or debris spitting or a ricochet.
- **ALWAYS BE ALERT AND ALWAYS FOLLOW THE SAFETY INSTRUCTIONS OF THE RANGE OFFICER.** Never shoot if you are tired, cold, or otherwise impaired in any way.
- **ALWAYS BE AWARE OF OTHER PEOPLE.** Be aware of others to ensure that persons do not accidentally walk into the line of fire.
- **THE SHOOTER (AND ALL OTHERS IN THE SHOOTING AREA) MUST ALWAYS BE IN A POSITION THAT IS OUT OF THE LINE OF FIRE AND NOT WITHIN AN AREA WHERE THEY MAY BE STRUCK BY A RICOCHET, OR PARTICLES SPITTING FROM A FIREARM, OR BY EJECTED CASES FROM THE FIREARM.**



PREPARATION FOR FIRING - CONTINUED

- **NEVER SHOOT AT SURFACES THAT MAY CAUSE A RICOCHET.**
Always select a place to shoot that has a safe backstop, is free from obstructions, and has no surfaces which may cause a ricochet.
 - **NEVER FIRE RANDOMLY INTO THE SKY.** Always select a place to shoot that has a safe backstop.
 - **NEVER USE ALCOHOL OR DRUGS BEFORE OR WHILE SHOOTING OR HANDLING ANY FIREARM.**
 - **REMEMBER, EACH TIME A CARTRIDGE IS FIRED AND A NEW CARTRIDGE IS CHAMBERED BY CYCLING THE ACTION, THE CROSS-BOLT SAFETY IS IN THE "FIRE" POSITION.** Therefore, if the rifle is not going to be fired immediately, the cross-bolt safety must be moved to the "NO-FIRE" position and the hammer lowered to the half-cock position.
 - **NEVER CARRY THE MODEL 1854 RIFLE WITH A ROUND IN THE CHAMBER AND THE CROSS-BOLT SAFETY IN THE "FIRE" POSITION.** If the rifle is dropped or struck with the cross-bolt safety in the "FIRE" position, the rifle may fire. Such an unintentional discharge can occur with or without the trigger being directly struck or touched.
 - **NEVER REST A LOADED MODEL 1854 RIFLE AGAINST ANY OBJECT OUT OF YOUR CONTROL.** There is always the possibility that the rifle can slip from its position and fall with enough force to induce an unintentional discharge. Keep the cross-bolt safety in the "NO-FIRE" position unless you are actually in the process of firing the rifle.
- 
- 

LOADING THE MODEL 1854



WARNING: ALWAYS KEEP THE MUZZLE OF THE FIREARM POINTED IN A SAFE DIRECTION.



WARNING: THE MODEL 1854 CAN BE FIRED WITH THE MAGAZINE TUBE REMOVED FROM THE FIREARM. KEEP YOUR FINGER OFF THE TRIGGER AND OUTSIDE THE TRIGGER GUARD UNTIL YOU HAVE MADE THE COMMITMENT TO FIRE.



WARNING: THE MODEL 1854 MUST NEVER BE KEPT IN THE CONDITION WITH THE SAFETY OFF AND THE HAMMER FULLY FORWARD ON A LIVE CARTRIDGE. IF THE HAMMER IS FULLY FORWARD ON A LIVE CARTRIDGE A SUFFICIENT IMPACT TO THE HAMMER OR SNAPPING THE HAMMER COULD CAUSE DISCHARGE. AN UNCONTROLLED DISCHARGE COULD CAUSE PERSONAL INJURY, DEATH, OR PROPERTY DAMAGE.



WARNING: THE MAGAZINE OF THE MODEL 1854 CAN ONLY BE LOADED THROUGH THE LOADING GATE ON THE RIGHT SIDE OF THE RECEIVER. NEVER INSERT CARTRIDGES INTO THE RIFLE FROM THE FOREND. ANY CARTRIDGE DROPPED INTO THE FOREND WILL CAUSE A STOPPAGE, BINDING, OR FAILURE TO FEED PROHIBITING PROPER USE OF THE RIFLE.

- Point the muzzle of the rifle in a safe direction, swing the operating lever fully down and forward and confirm that no cartridges have been loaded (FIGURE 30).

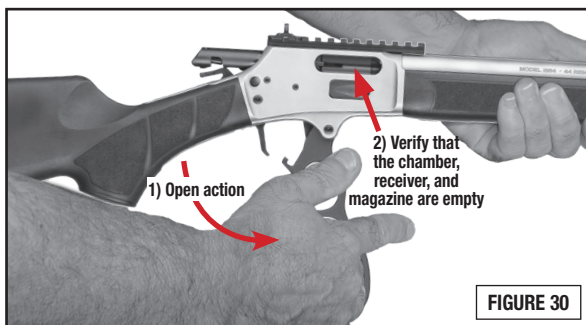

FIGURE 30

- Press the cross-bolt safety fully right to the “NO-FIRE” position (FIGURE 31).
- Close the action by pulling the operating lever fully up and back. The operating lever needs to be in the closed position to allow loading.



FIGURE 31

LOADING THE MODEL 1854 - CONTINUED

- The MODEL 1854 lever-action rifle is loaded through the loading port located on the right side of the receiver (as viewed from above or from the rear). The loading port is covered by a spring-loaded loading gate.
- Do not load the rifle until you have read and fully understand this manual.
- Do not load the chamber of the rifle until you are ready to use it. Keep your finger off the trigger and outside the trigger guard until you are ready to fire.
- Never load your rifle until you are sure of your target, what is beyond it, and are fully prepared to fire.
- With the bullet end of the cartridge pointing toward the muzzle, insert the cartridge into the loading gate and press it down and forward into the magazine tube (FIGURE 32) until the loading gate springs back (FIGURE 33). Load the desired number of cartridges - up to the rifle's capacity.

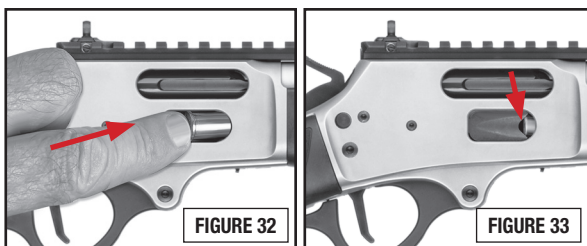

- The magazine is now loaded.
- By cycling the operating lever fully down and forward and then closing it, the rifle's chamber will be loaded.

LOADING THE MODEL 1854 - CONTINUED

- If you are not going to fire immediately, ensure that the cross-bolt safety is fully to the right in the “NO-FIRE” position and proceed to lower the hammer from the cocked position to the half-cock position by holding the hammer spur firmly, pulling the trigger just long enough to release the hammer (FIGURE 34), removing finger from trigger and then lowering the hammer to half-cock.

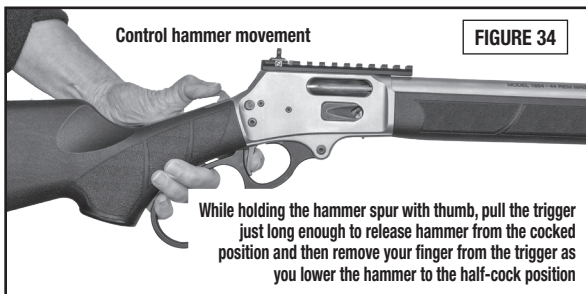

To Load a Single Round Into the Chamber

- Starting with the chamber, receiver, and magazine tube empty, press the operating lever fully down and forward to open the action (FIGURE 35).
- Once the action is open, move the cross-bolt safety fully to the right in the “NO-FIRE” position (as viewed from above or from the rear) (FIGURE 36).
- Place one cartridge of the correct caliber through the ejection port onto the elevator with the bullet pointed toward the muzzle (FIGURE 37).
- Close the action by pulling the operating lever fully rearward and up, thereby locking the cartridge in the chamber.
- The rifle is now loaded with a cartridge in the chamber, the cross-bolt safety in the “NO-FIRE” position and the hammer cocked.

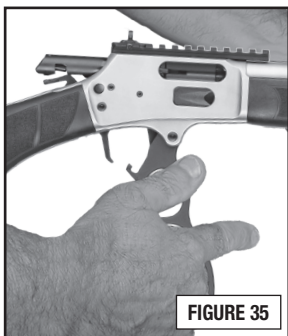

FIRING THE MODEL 1854



WARNING: ALWAYS KEEP THE MUZZLE OF THE FIREARM POINTED IN A SAFE DIRECTION.



WARNING: WEAR EYE AND HEARING PROTECTION SPECIFIED FOR FIREARM USE EVERY TIME YOU DISCHARGE YOUR FIREARM. MAKE SURE OTHERS IN THE VICINITY OF WHERE YOU WILL BE SHOOTING DO SO AS WELL.

- Grasp firearm with one hand on the forend and other hand on the grip with finger resting outside the trigger guard. Raise the firearm and pull buttstock firmly into your shoulder (FIGURE 38).

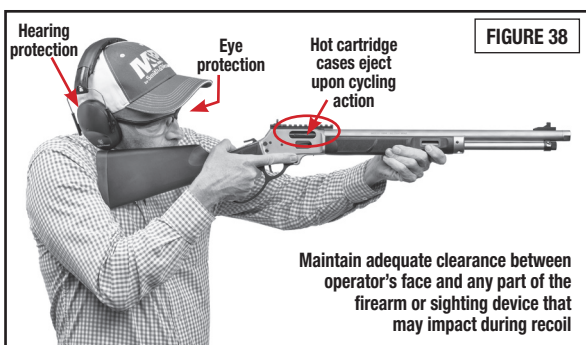

- The rifle can now be fired by moving the cross-bolt safety fully to the left (as viewed from above or from the rear) into the “FIRE” position (when the red o-ring on the cross-bolt safety is visible) and the trigger is then pulled.
- Cycling the operating lever fully forward and back closed again ejects the empty case and chambers the next cartridge. You may continue to fire by cycling the operating lever and pulling the trigger until the magazine tube, receiver and chamber are empty.

NOTE: Smith & Wesson® recommends that the user work the operating lever briskly during normal use. Cycling the lever slowly tends to increase the chances of encountering a failure to feed a round into the chamber smoothly and a failure to eject.

- When firing the MODEL 1854 lever-action rifle, ensure that bystanders are well clear of the shooter and standing a safe distance to the rear.



WARNING: EMPTY CARTRIDGE CASES ARE HOT AND ARE EJECTED FROM THE RIFLE TO THE RIGHT SIDE. HOT CARTRIDGE CASES COULD CAUSE INJURY TO ANY PERSON THAT IS TOO CLOSE TO THE EJECTION PORT. LEFT-HANDED SHOOTERS SHOULD BE ESPECIALLY CAUTIOUS ABOUT HOT CARTRIDGE CASES BEING EJECTED TOWARD THEIR BODY.

FIRING THE MODEL 1854 - CONTINUED

- If you wish to stop firing before the magazine is empty, remove your finger from the trigger and keep it outside the trigger guard.

NOTE: The next steps will vary - depending on where the hammer is when you stop firing.

If the hammer is against the bolt (having just fired a round) the user needs to place the hammer at half-cock before the cross-bolt safety can be moved (see page 16).

If the hammer is cocked and a live round is in the chamber, the cross-bolt safety needs to be moved to the “NO-FIRE” position and the hammer then lowered to half-cock (see page 17).

- In any case, the cross-bolt safety needs to end up fully to the right in the “NO-FIRE” position (FIGURE 39) and the hammer needs to end up in the half-cock position (FIGURES 40 and 41).



WARNING: ALWAYS KEEP THE MUZZLE OF THE FIREARM POINTED IN A SAFE DIRECTION.



FIGURE 39

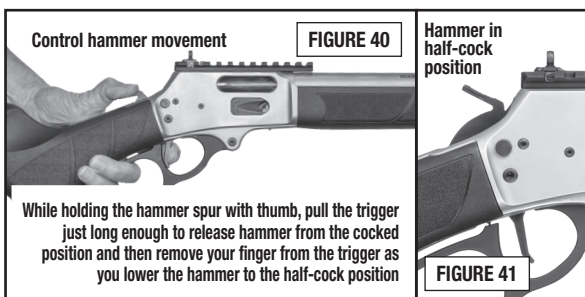

- Remember, the bolt is closed and there is still a cartridge in the chamber and there are possibly more cartridges in the magazine tube.
- If you are done firing and want to unload the rifle, open the operating lever fully and place the cross-bolt safety fully to the right into the “NO-FIRE” position. Proceed to empty the magazine and receiver (see page 31).
- Ensure that the firearm chamber, receiver and magazine are empty before cleaning, transporting, or storing the rifle.

HANGFIRES AND MISFIRES



WARNING: ALWAYS KEEP THE MUZZLE OF THE FIREARM POINTED IN A SAFE DIRECTION.



WARNING: WEAR EYE AND HEARING PROTECTION THAT IS SPECIFIED FOR USE WITH FIREARMS WHEN FIRING AND CLEARING MISFIRES OR MISFEEDS.



WARNING: KEEP YOUR FACE A SAFE DISTANCE FROM THE EJECTION PORT WHEN CLEARING A CARTRIDGE. IF A CARTRIDGE IGNITES WHILE BEING CLEARED FROM THE FIREARM, INJURY OR DEATH MAY RESULT.



WARNING: IF YOUR FIREARM GIVES ANY INDICATION THAT IT IS NOT PERFORMING PROPERLY OR THE OPERATION OF YOUR FIREARM HAS CHANGED “THE WAY IT FEELS OR SOUNDS,” STOP FIRING. MAKE SURE THE FIREARM IS POINTED IN A SAFE DIRECTION, UNLOAD THE FIREARM AND HAVE IT INSPECTED AND TEST FIRED BY A GUNSMITH QUALIFIED TO PERFORM SERVICE ON SMITH & WESSON® FIREARMS.

NOTE: In the case of either a hangfire or misfire, keep the muzzle of the firearm pointed in a safe direction and keep your finger off the trigger. Wait 60 seconds before opening the action and proceeding to clear the cartridge from the chamber.

- A **HANGFIRE** is described as a noticeable delay between the impact of the firing pin on the primer of the cartridge and the actual discharge of the firearm. This is generally caused by defective or damaged ammunition.
- If a cartridge has delayed ignition, with the firearm pointed in a safe direction, the firearm should be unloaded. The remainder of similar ammunition should be inspected to determine if it has been contaminated or damaged and dealt with accordingly.
- A **MISFIRE** is the failure of the chambered cartridge to fire at all after the trigger has been pulled. This is generally caused by defective or damaged ammunition or a dirty or fouled firearm.
- A light primer strike caused by a dirty or fouled firearm can lead to misfires. If a light strike on the primer of a misfire is noted, unload the firearm and clean it as instructed in the “*Cleaning and Maintenance*” section of this manual (page 43). If a cartridge does not go off when the trigger is pulled, the “dud” cartridge needs to be removed from the firearm and disposed of properly.



HANGFIRES AND MISFIRES - CONTINUED

- The firearm should be inspected and thoroughly cleaned before returning it to use.
- The ammunition should be inspected. Damaged or defective cartridges should not be used.
- Dispose of defective cartridge(s) in a method specifically approved for live cartridge disposal.

CLEARING A MISFEED/JAM



WARNING: KEEP YOUR FACE A SAFE DISTANCE FROM THE EJECTION PORT WHEN CLEARING A MISFED/JAMMED CARTRIDGE. A CARTRIDGE MAY IGNITE IF THE PRIMER OF THE CARTRIDGE IS STRUCK WITH SUFFICIENT FORCE. IF A CARTRIDGE IGNITES WHILE BEING CLEARED FROM THE FIREARM, INJURY AND/OR DEATH MAY RESULT.

NOTE: It is advisable to work the operating lever briskly. Cycling the lever slowly tends to increase the chances of encountering a failure to feed or failure to chamber a round smoothly.

NOTE: Any repeating firearm may, on occasion, fail to feed a cartridge properly from the magazine and into the chamber. To clear a misfeed/jam:

- Make certain that the muzzle of the firearm is pointed in a safe direction.

NOTE: Cycling the operating lever down and fully forward (thereby opening the bolt) should allow clearance for the jammed cartridge to fall free and clear of the firearm.

- It may be necessary to manually remove a jammed cartridge. When attempting to clear a jam manually, use only wood or plastic 'tools', such as a pointed dowel or a pencil, and use extreme care to avoid striking the primer of the cartridge.
- Visually check to make sure all cartridges have been removed from the firearm.
- Once the misfed cartridge is cleared, proceed to load the firearm as instructed in the "Loading the MODEL 1854" section of this manual (page 24).



CLEARING A MISFEED/JAM - CONTINUED

- Dispose of defective cartridge(s) in a method specifically approved for live cartridge disposal.

UNLOADING THE MODEL 1854



WARNING: ALWAYS KEEP THE MUZZLE OF THE FIREARM POINTED IN A SAFE DIRECTION.



WARNING: REMOVING THE MAGAZINE TUBE FROM THE MODEL 1854 DOES NOT UNLOAD THE CHAMBER OR RECEIVER. ALWAYS ENSURE THAT THE CHAMBER, AND THE RECEIVER ARE EMPTY.

- Upon being presented a MODEL 1854 rifle, you must first make certain that it is in a mode whereby it can be handled safely.

- Without touching the trigger, grasp the operating lever and pull/push it down and fully forward. This renders the firing pin inoperable and engages the trigger block. It also extracts and ejects any cartridge that may have been chambered (FIGURE 42).

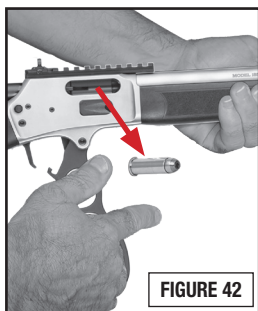

- Once the action is open, move the cross-bolt safety fully to the right in the "NO-FIRE" position (as viewed from above or from the rear) (FIGURE 43).



- With the action open, you must determine whether any cartridges have been loaded into the magazine tube previously. If there is a cartridge present on the elevator (while viewing into the ejection port - FIGURE 44) the user needs to tip the rifle until the cartridge falls out of the rifle through the ejection port.



UNLOADING THE MODEL 1854 - CONTINUED

WARNING: PRIOR TO UNLATCHING THE MAGAZINE TUBE, THE ACTION SHOULD BE OPENED BY PULLING THE OPERATING LEVER FULLY DOWN AND FORWARD AND THE CROSS-BOLT SAFETY SHOULD BE PLACED FULLY TO THE RIGHT INTO THE "NO-FIRE" POSITION.

WARNING: REMOVING THE MAGAZINE TUBE FROM THE MODEL 1854 DOES NOT UNLOAD THE CHAMBER OR THE RECEIVER.

- If multiple rounds were loaded into the magazine tube, the magazine tube needs to be emptied. This can be accomplished in several ways:

- The first way to empty the magazine tube is to keep the rifle pointed in a safe direction with the cross-bolt safety pressed fully to the right in the "NO-FIRE" position (FIGURE 45), then unlatch the magazine tube and withdraw it completely from its standard position (FIGURE 46) - and then dump the cartridges out of the rifle by tipping it down at the muzzle (FIGURE 47).

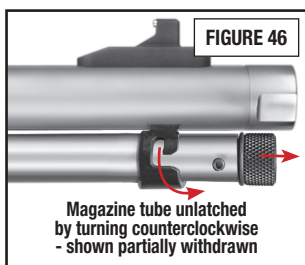
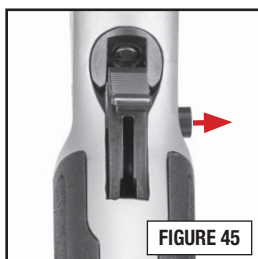

WARNING: ENSURE THAT THE CHAMBER, THE RECEIVER AND THE MAGAZINE TUBE ARE ALL EMPTY BEFORE CONTINUING.

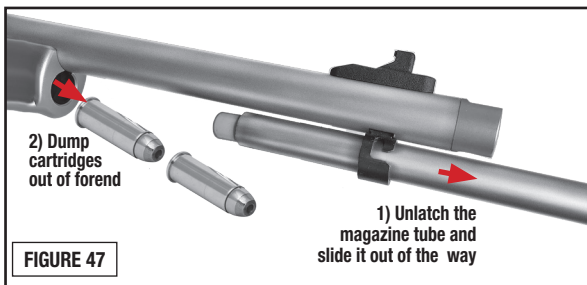

- Return the magazine tube to its position under the barrel and latch the magazine tube into place.

UNLOADING THE MODEL 1854 - CONTINUED

- The second way to empty the magazine tube is to keep the rifle pointed in a safe direction with the cross-bolt safety pressed fully to the right in the “NO-FIRE” position (FIGURE 48) and cycle the operating lever fully forward and then closed - to chamber and extract each cartridge (FIGURE 49) until the chamber, magazine and receiver are empty.



NOTE: The operating lever must be completely closed and then fully opened to ensure proper feeding and ejection from the rifle of all cartridges that have been loaded.

- Once the rifle is cleared of any ammunition, the action can be closed by pulling the operating lever fully back and up and the hammer can then be lowered to the half-cock position (FIGURE 50).

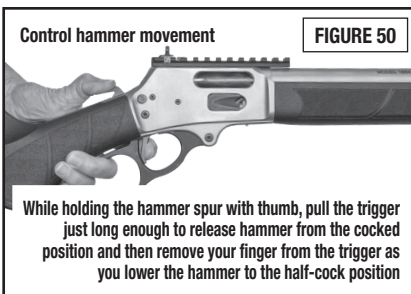

- Collect live ammunition for safe storage and spent cartridge cases for proper disposal.

DISASSEMBLY/FIELD STRIPPING



WARNING: ALWAYS KEEP THE MUZZLE OF THE FIREARM POINTED IN A SAFE DIRECTION.



WARNING: ENSURE THAT THE FIREARM IS UNLOADED BEFORE ATTEMPTING TO DISASSEMBLE/FIELD STRIP.



WARNING: WEAR SAFETY GLASSES THAT ARE SPECIFIED FOR FIREARMS USE EVERY TIME YOU DISASSEMBLE OR ASSEMBLE YOUR FIREARM.



WARNING: NEVER DISASSEMBLE YOUR FIREARM BEYOND THE DISASSEMBLY/FIELD STRIPPING PROCEDURE DETAILED IN THIS MANUAL, OR PERFORM ANY MAINTENANCE, ADJUSTMENT, OR SERVICE NOT SPECIFIED. IMPROPER DISASSEMBLY AND REASSEMBLY OF YOUR FIREARM MAY LEAD TO INJURY OR DEATH OF THE SHOOTER AND/OR BYSTANDERS AND DAMAGE TO PROPERTY.



WARNING: NEVER MODIFY OR SWAP OUT ANY OF THE COMPONENTS OF YOUR SMITH & WESSON® FIREARM, UNLESS SPECIFICALLY INSTRUCTED TO DO SO IN THIS MANUAL OR IN AN OFFICIAL SMITH & WESSON ACCESSORY PARTS MANUAL OR INSTRUCTION SHEET. CHANGES NOT COVERED IN THIS MANUAL OR IN A SMITH & WESSON INSTRUCTION SHEET WILL REQUIRE A QUALIFIED GUNSMITH (OR FACTORY-TRAINED PERSONNEL) USING FACTORY-AUTHORIZED PARTS. IMPROPER MANIPULATION OF ANY COMPONENT OF THE FIREARM MAY RESULT IN FAULTY FUNCTIONING, POSSIBLY LEADING TO INJURY OR DEATH OF THE SHOOTER AND/OR BYSTANDERS AND DAMAGE TO PROPERTY.

- Open the action by pulling the operating lever down and fully forward (FIGURE 51).

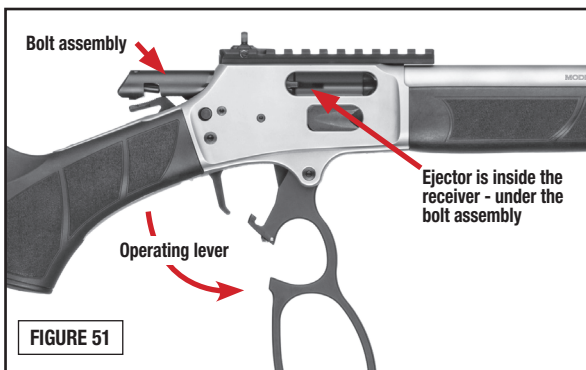

- The operating lever, the bolt assembly and the ejector are the only action parts that should be removed from the rifle by the user.

DISASSEMBLY/FIELD STRIPPING - CONTINUED

- Open the action by pulling the operating lever down and forward. Remove the operating lever pivot screw from the frame using a T20 Torx® screwdriver (FIGURES 52 and 53).

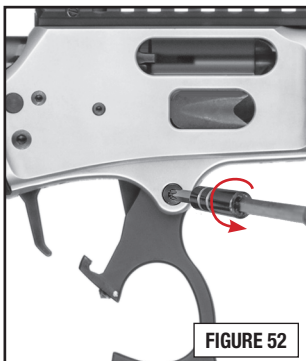

- The operating lever can now be pulled down, out of the receiver once the pivot screw is removed (FIGURE 54).
- Hold the hammer spur down firmly to relieve the tension against the bolt assembly (FIGURE 55a) and pull the bolt rearward, out of the receiver.
- (FIGURE 55b) shows the bolt upon removal.

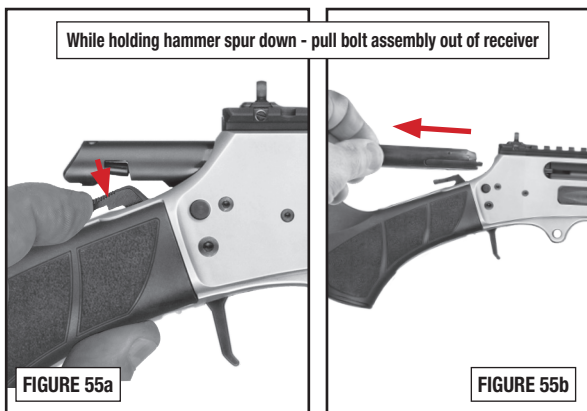

Torx, is a registered trademark of Acument Intellectual Properties, LLC.

DISASSEMBLY/FIELD STRIPPING - CONTINUED

- Using tweezers or small needle-nose pliers, reach into the receiver through the ejection port and lift out the ejector from its recess (FIGURES 56 and 57).

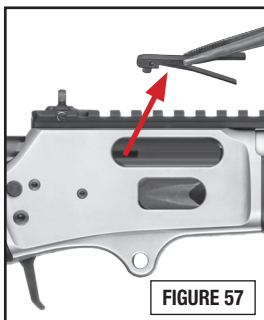

- The bore of the rifle can now be cleaned from the breech end.
- The bolt assembly can be cleaned and lubricated.
- The operating lever can be cleaned and lubricated.
- The internal surfaces of the receiver can be cleaned.
- The magazine tube can be unlatched and withdrawn from its position below the barrel to be cleaned if needed.
- The thread protector on the muzzle (if rifle is so-equipped) can be removed and the threads cleaned and lubricated.
- No further disassembly is recommended.

ASSEMBLY



WARNING: WEAR SAFETY GLASSES EVERY TIME YOU ASSEMBLE OR DISASSEMBLE YOUR FIREARM.



WARNING: NEVER MODIFY OR SWAP OUT ANY OF THE COMPONENTS OF YOUR SMITH & WESSON® FIREARM, UNLESS SPECIFICALLY INSTRUCTED TO DO SO IN THIS MANUAL OR IN AN OFFICIAL SMITH & WESSON ACCESSORY PARTS MANUAL OR INSTRUCTION SHEET. CHANGES NOT COVERED IN THIS MANUAL OR IN A SMITH & WESSON INSTRUCTION SHEET WILL REQUIRE A QUALIFIED GUNSMITH (OR FACTORY-TRAINED PERSONNEL) USING FACTORY-AUTHORIZED PARTS. IMPROPER MANIPULATION OF ANY COMPONENT OF THE FIREARM MAY RESULT IN FAULTY FUNCTIONING, POSSIBLY LEADING TO INJURY OR DEATH OF THE SHOOTER AND/OR BYSTANDERS AND DAMAGE TO PROPERTY.

ASSEMBLY - CONTINUED

- Using tweezers or small needle-nose pliers, place the ejector into the receiver recess (FIGURES 58 and 59) until the round extrusion on the ejector engages the hole in the receiver.

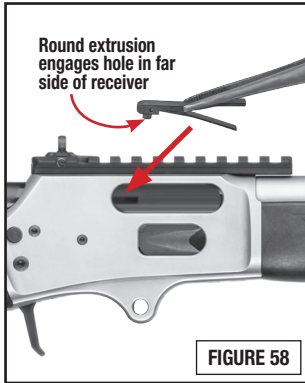

- If the bolt locking lug has moved upward inside the receiver (FIGURE 60), simply push it back down to allow clearance for the bolt to enter the channel within the receiver.
- Hold the hammer spur down while inserting bolt assembly into the receiver (FIGURES 61 and 62). Insert the bolt about halfway - aligning slot in bolt with ejector inside the receiver.

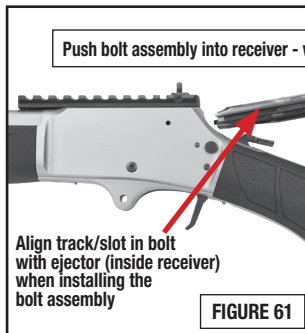

ASSEMBLY - CONTINUED

- Insert the operating lever into the receiver and engage the slot in the bolt assembly - see note below.

IMPORTANT NOTE:

When reassembling, the bolt assembly should be pushed no more than half-way into receiver (FIGURE 63) to allow operating lever to engage the slot upon reinstallation.

1) If the bolt is pushed too far forward, the slot will not align, hold the rifle horizontal and push the bolt back slightly with a cleaning rod inserted from the muzzle end to get the bolt slot where it can be aligned with the operating lever.

2) If the bolt assembly is not pushed in enough (too far back), the user will find that other internal parts may interfere while trying to get the end of the operating lever into the slot on the bolt.

(FIGURE 64) shows where the end of the operating lever engages the bolt assembly.

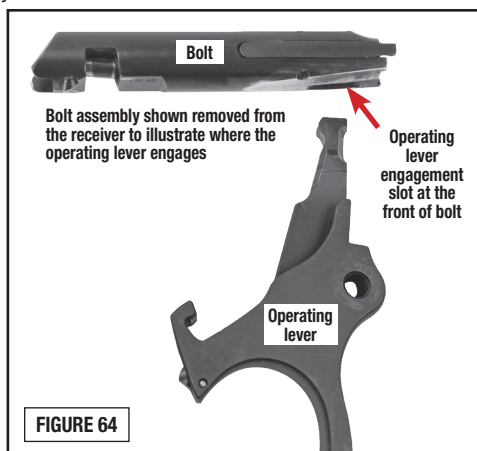
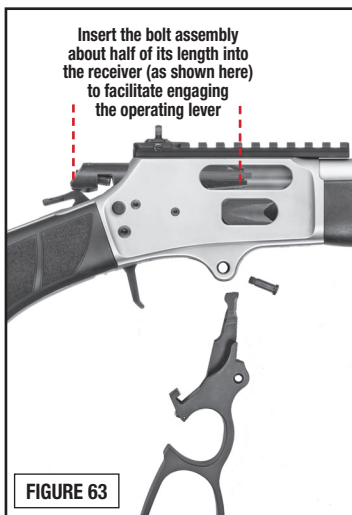

ASSEMBLY - CONTINUED

- Align the holes in the operating lever and the trigger plate and insert the pivot screw (FIGURE 65).
- Tighten the pivot screw until it is snug (FIGURE 66).

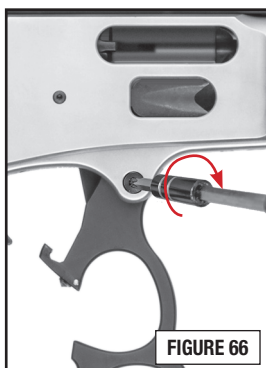
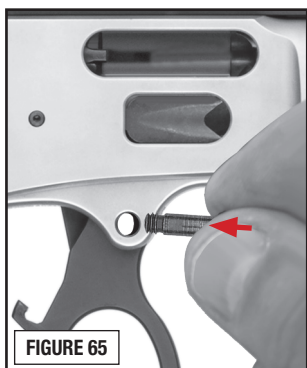

- Cycle the unloaded rifle several times by closing and then opening the action with the operating lever to confirm smooth operation.



WARNING: INCORRECTLY ASSEMBLING THE MODEL 1854 OR THE USE OF MODIFIED OR REPLACEMENT PARTS CAN RESULT IN PERSONAL INJURY OR DEATH TO THE USER OR BYSTANDERS AND DAMAGE TO PROPERTY.

IF THE MODEL 1854 RIFLE DOES NOT FUNCTION CORRECTLY AFTER ASSEMBLY, IT SHOULD BE RETURNED TO THE FACTORY FOR INSPECTION AND REPAIR, IF REQUIRED. SEE "CONTACT & SHIPPING INFORMATION" (PAGE 48) OF THIS MANUAL FOR RETURN AND SHIPPING INFORMATION.

OFFSET HAMMER SPUR EXTENSION



WARNING: ALWAYS KEEP THE MUZZLE OF THE FIREARM POINTED IN A SAFE DIRECTION.



WARNING: MAKE SURE THAT THE FIREARM IS UNLOADED BEFORE INSTALLING OR REMOVING THE HAMMER SPUR EXTENSION.

- An offset hammer spur is included with the rifle from the factory. This helps the user to more easily cock and uncock the hammer when a scope is mounted on the rifle.
- The offset hammer spur can be mounted on either the right or left side of the hammer (FIGURE 69). Secure the offset hammer spur extension to the hammer by sliding it onto the hammer spur and then tightening the set screw with a 1/16" Allen wrench.

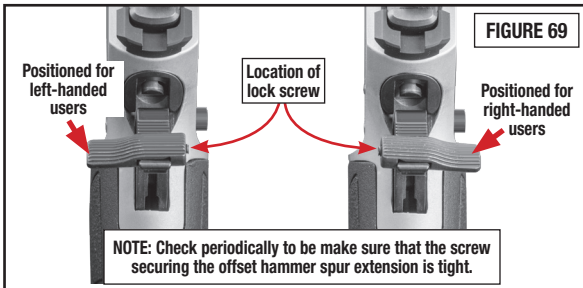

M-LOK® FOREND SLOTS (if so-equipped)



WARNING: ALWAYS KEEP THE MUZZLE OF THE FIREARM POINTED IN A SAFE DIRECTION.



WARNING: MAKE SURE THAT THE FIREARM IS UNLOADED BEFORE INSTALLING OR REMOVING ACCESSORIES.

- The forend on some models is equipped with three M-LOK® slots (FIGURE 70) to allow the mounting of various accessories (sold separately).

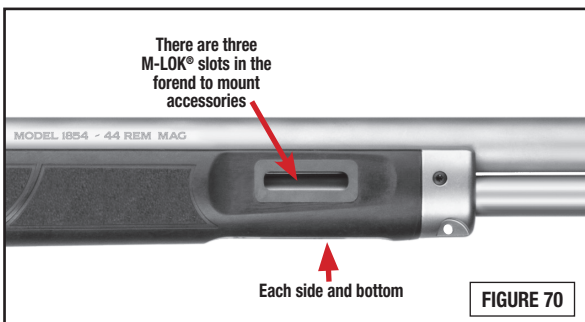

- Prior to mounting any M-LOK accessories, the magazine tube should be removed from the rifle to allow clearance.
- Follow the instructions provided to install or remove your accessory.

NOTE: Due to the close proximity of the magazine tube below these slots, the screws on some M-LOK accessories may need to be shortened to avoid damaging the magazine tube and interfering with magazine tube clearance as it is installed or removed. Do not force the magazine tube into the forend if the mounting screws interfere.

INSTALLATION OF SIGHTS/OPTICS

WARNING: ENSURE THAT THE FIREARM IS UNLOADED BEFORE INSTALLING A SIGHT, A SCOPE, OR ANY OTHER ACCESSORIES. FAILURE TO DO THIS CAN RESULT IN INJURY OR DEATH TO YOU OR OTHERS AND DAMAGE TO PROPERTY.

WARNING: FIRING A FIREARM WITH YOUR EYE TOO CLOSE TO THE EYE PIECE OF A SCOPE OR OPTICAL SIGHT, OR FAILING TO HOLD THE FIREARM SECURELY AGAINST RECOIL, MAY RESULT IN PERSONAL INJURY INCLUDING, BUT NOT LIMITED TO, BLINDNESS.

WARNING: A SIGHT OR SCOPE WHICH IS NOT SECURELY MOUNTED MAY BECOME DETACHED UPON RECOIL OF THE FIREARM. IF IT BECOMES DETACHED IT MAY FLY BACK AND STRIKE THE SHOOTER OR A BYSTANDER AND CAUSE INJURY. OBSERVE THE CONDITION OF ALL THE SCOPE MOUNT SCREWS AFTER FIRING. IF THE MOUNTING SCREWS SHOW SIGNS OF LOOSENING DO NOT FIRE THE GUN AGAIN; CALL THE CUSTOMER SERVICE DEPARTMENT FOR ASSISTANCE AT 1-800-331-0852 EXT 4125.

- We recommend that you have a competent gunsmith install your scope and mount.
- Scopes and optical sights have varying lengths of recommended eye relief. You need to choose a combination that allows for adequate clearance between the scope and your eye. Follow the instructions supplied with the scope and mounts for proper installation (FIGURE 71).

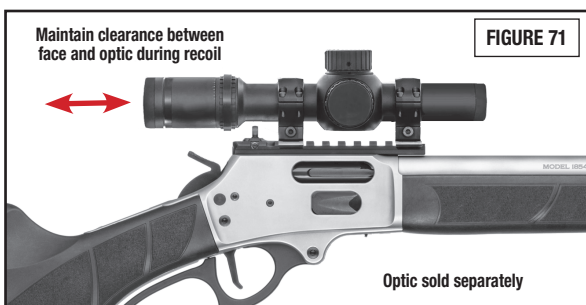

- Removal of rear sight may be necessary to provide clearance for mounting some scopes. If the rear peep sight is removed, the slotted screw that holds the peep sight in place needs to be replaced with a Torx screw - to hold the Picatinny-style rail firmly to the receiver. (2) Torx screws are included with the rifle (rear sight covers one of the holes for rail mounting screws).

REAR SIGHT ADJUSTMENT



WARNING: ALWAYS KEEP THE MUZZLE OF THE FIREARM POINTED IN A SAFE DIRECTION.



WARNING: MAKE SURE THAT THE FIREARM IS UNLOADED BEFORE ADJUSTING THE SIGHTS.

- (FIGURE 72) In adjusting the sights - move the rear sight in the direction that you want the bullets to strike on target, i.e. if you want the bullets to strike the target more to the left, move the rear sight to the left. If you want the bullets to strike higher on the target, move the rear sight up.

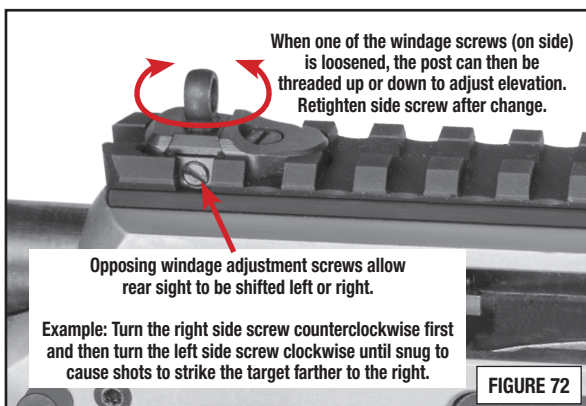

CLEANING AND MAINTENANCE



WARNING: ENSURE THAT YOUR FIREARM IS UNLOADED BEFORE BEGINNING TO CLEAN IT. ALWAYS FOLLOW THE RULES OF SAFE FIREARM HANDLING.



WARNING: WEAR SAFETY GLASSES EVERY TIME YOU ASSEMBLE OR DISASSEMBLE YOUR FIREARM AND ATTEMPT CLEANING OR MAINTENANCE.



WARNING: ALWAYS HAVE ADEQUATE VENTILATION. CLEANING FIREARMS IN POORLY VENTILATED AREAS, DISCHARGING FIREARMS, OR HANDLING AMMUNITION MAY RESULT IN EXPOSURE TO LEAD AND OTHER SUBSTANCES KNOWN TO CAUSE BIRTH DEFECTS, REPRODUCTIVE HARM AND OTHER PHYSICAL INJURY. WASH HANDS THOROUGHLY AFTER EXPOSURE.

CLEANING AND MAINTENANCE - CONTINUED



WARNING: NEVER DISASSEMBLE YOUR FIREARM BEYOND THE FIELD STRIPPING/DISASSEMBLY PROCEDURE DETAILED IN THIS MANUAL, OR PERFORM ANY MAINTENANCE, ADJUSTMENT, OR SERVICE NOT SPECIFIED. IMPROPER DISASSEMBLY AND REASSEMBLY OF YOUR FIREARM MAY LEAD TO INJURY OR DEATH OF THE SHOOTER AND/OR BYSTANDERS AND DAMAGE TO PROPERTY.



WARNING: NEVER MODIFY OR SWAP OUT ANY OF THE COMPONENTS OF YOUR SMITH & WESSON® FIREARM, UNLESS SPECIFICALLY INSTRUCTED TO DO SO IN THIS MANUAL OR IN AN OFFICIAL SMITH & WESSON ACCESSORY PARTS MANUAL OR INSTRUCTION SHEET. CHANGES NOT COVERED IN THIS MANUAL OR IN A SMITH & WESSON INSTRUCTION SHEET WILL REQUIRE A QUALIFIED GUNSMITH (OR FACTORY-TRAINED PERSONNEL) USING FACTORY-AUTHORIZED PARTS. IMPROPER MANIPULATION OF ANY COMPONENT OF THE FIREARM MAY RESULT IN FAULTY FUNCTIONING, POSSIBLY LEADING TO INJURY OR DEATH OF THE SHOOTER AND/OR BYSTANDERS AND DAMAGE TO PROPERTY.

- Before using your firearm for the first time, it should be cleaned.
- Your firearm was treated at the factory with either a preservative or oil to protect it against corrosion during shipping and storage.
- Preservative and oil should be wiped from the bore, chamber and exposed areas using a clean swab or patch before using the firearm.

NOTE: A basic firearm cleaning kit should include: a brass bore brush and a cleaning jag of appropriate size for the bore being cleaned, high-quality gun cleaning solvent and gun oil/lubricant, cotton cleaning patches and a cleaning rod that is long enough to push the brush and jag completely through the barrel.

- Purchase cleaning supplies from your firearms dealer that are specifically designated for your type and caliber of firearm. Many suppliers offer these in kit form for your convenience.
- Follow the instructions provided with your cleaning supplies.
- Remove excessive firing residue from the bore and chamber using a properly fitted brass brush dipped in gun cleaning solvent. Finish the bore cleaning process by running a dry cotton cloth patch through the bore and chamber to remove residue and solvent.
- Clean the exterior of the firearm using a non-abrasive cleaning cloth.





CLEANING AND MAINTENANCE - CONTINUED

- After cleaning, lightly coat the metal parts, internal and external with a high quality firearm oil.
- Whenever your firearm has been exposed to sand, dust, extreme humidity, water or other adverse conditions, it must be cleaned and lubricated.

CAUTION: Always follow the instructions provided with your firearm cleaner and firearm lubricant.

CAUTION: Some cleaners can cause damage to your firearm. You should avoid prolonged solvent immersion and prolonged ultrasonic cleaning of your firearm. Choice of solvent should be restricted to those products specifically developed for firearms maintenance. Damage to a firearm's finish may occur if these cautions are ignored. Ammoniated solvents or other strong alkaline solvents should not be used on any Smith & Wesson® firearm. Cleaning is essential to ensure the proper functioning of your firearm.

- Your firearm is a precision instrument. To ensure reliable function it is necessary to follow a routine maintenance procedure. After firing your firearm, be sure to unload it following the procedure outlined in the section entitled "*Unloading The MODEL 1854*" (page 31) before performing any cleaning or maintenance procedure.
 - Remove any firearm cleaning solution, oil and fingerprints from the outside surfaces of the firearm. Finger moisture, if left, could start a corrosion process.
 - If your firearm will be used in a cold climate, be sure to use an oil of an appropriate weight so that it will not congeal in cold temperatures, causing the interaction of important parts to be slowed or halted.
 - Every time you clean your firearm, check it for signs of wear. If excessive wear is noted, do not use the firearm. Return it to Smith & Wesson® for service or have it checked by a qualified gunsmith.
- 
- 

CLEANING AND MAINTENANCE - CONTINUED

MAINTENANCE BEFORE STORAGE

- When storing, do not encase your firearm in anything that will attract or hold moisture, for example, leather or heavy cloth. Also, do not store firearms with a plug inserted in the barrel, for this can be a contributing factor to moisture accumulation. If your firearm is to be stored for an extended period, the bore, chamber and internal surfaces should be oiled with a high quality lubricating oil or preservative intended for firearms.
- The metal parts of the firearm; bolt and barrel should be lightly coated with an anti-rust oil. Before using your firearm again, be sure to clean it.

LUBRICATION

- After cleaning your MODEL 1854 rifle, apply a small amount of good quality gun oil on the pivot points and bearing surfaces of the rifle (FIGURES 73 and 74).

Avoid applying too much oil as it may attract and hold dirt and become gummed up.

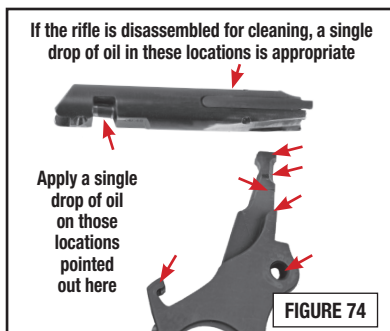
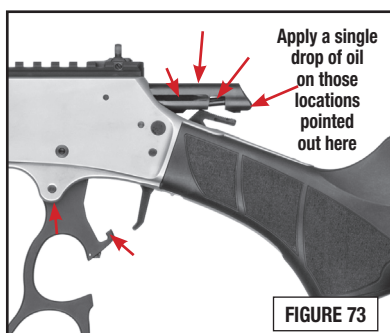



LIMITED WARRANTY

For Owners Within The United States

This warranty is granted by Smith & Wesson® Brands Inc. This warranty is effective from the date of purchase and applies to the original owner of any firearm. With respect to such firearms, this warranty supersedes any and all other warranties.

Smith & Wesson® firearms are warranted to be free from defects in material and workmanship. Any such defects of which Smith & Wesson® receives written notice within one year from the date of purchase by the original owner, will be remedied by Smith & Wesson® without charge within a reasonable time after such notification and delivery of the firearm as provided below.

In the event of an emergency (repairs needed by law enforcement, an upcoming match or hunting trip), call 1-800-331-0852, ext. 4125 and ask for 911 Priority Repair Service. This allows you to speak with a Smith & Wesson® representative. Immediately upon receipt, your firearm will be assigned to a gunsmith. After the work is completed, we will return your Smith & Wesson® firearm via overnight delivery.

Warranty claims (in writing) and the firearm concerned should be delivered to Smith & Wesson's Customer Service Department, 2100 Roosevelt Avenue, Springfield, Massachusetts 01104. In addition, a copy of the bill of sale in the owner's name, or a copy of ATF Form 4473 indicating date of purchase must be included. It is important that the owner comply with all applicable federal, state and local laws and regulations in the shipment of firearms to Smith & Wesson®.

NOTE: See the “*Contact and Shipping*” section of this manual (page 48) for further details regarding returns.

Warranty claims should state the model and serial number of the firearm concerned and the description of the difficulty experienced. It is recommended that shipments be insured by the owner, since Smith & Wesson® will accept no responsibility for loss or damage in transit. Transportation and insurance charges for return to owner will be paid by Smith & Wesson® if the claim is covered by the warranty.

UNDER NO CIRCUMSTANCES SHALL SMITH & WESSON® BE RESPONSIBLE FOR INCIDENTAL OR CONSEQUENTIAL DAMAGES WITH RESPECT TO ECONOMIC LOSS, INJURY, DEATH OR PROPERTY DAMAGE, WHETHER AS A RESULT OF BREACH OF THIS WARRANTY, NEGLIGENCE OR OTHERWISE.

Some states do not allow the exclusion or limitation of incidental or consequential damages, so the above limitation or exclusion may not apply to you.







LIMITED WARRANTY - CONTINUED

Smith & Wesson® will not be responsible for:

- Defects or malfunctions resulting from careless handling, unauthorized adjustments or modifications made or attempted by anyone other than a qualified gunsmith following Smith & Wesson® authorized procedures, or failure to follow the disassembly instructions in the Smith & Wesson® Safety and Instruction Manual.
- Use of defective or improper ammunition, corrosion, neglect, abuse, ordinary wear and tear, or unreasonable use.
- Criminal misuse, negligence or use under the influence of drugs or alcohol.

Smith & Wesson's Lifetime Service Policy begins after the warranty period has expired. Smith & Wesson® will repair, without charge, for the lifetime of the original owner, any Smith & Wesson® MODEL 1854 that is found to have a defect in material or workmanship. Eligibility for this Lifetime Service Policy requires returning the Product Registration Card within 30 days of purchase. The Lifetime Service Policy covers functional defects; it does not include the firearm's finish, grips, magazines or sights. The Lifetime Service Policy is in addition to and not an extension of the Smith & Wesson® Warranty. This warranty gives you specific legal rights. You may also have other rights that vary from state to state.



NOTE: All liability is excluded in the event that the instructions in this Smith & Wesson® Safety and Instruction Manual are not observed.



CONTACT & SHIPPING INFORMATION

For Owners Within The United States

NOTE: A Return Merchandise Authorization (RMA) is the first step in the process of returning a product in order to receive a repair, replacement or refund. Please contact Smith & Wesson's Customer Service Dept. (via e-mail: qa@smith-wesson.com or by phone at 1-800-331-0852 ext. 4125) to obtain authorization to return your firearm so we can process it quickly and efficiently. The RMA number that is supplied by Smith & Wesson® must be displayed on the outside of the returned product's packaging; returns without an RMA number will be routed differently which will result in delayed processing.

The issuance of a Return Merchandise Authorization (RMA) allows Smith & Wesson® an opportunity to try to diagnose and correct a customer's concerns with the product (such as ammunition problems) before it is returned. Accordingly, please contact us before returning your Smith & Wesson® firearm.

CONTACT CUSTOMER SERVICE

Tel: 1-800-331-0852 • 1-413-781-8300 ext. 4125

E-mail: qa@smith-wesson.com

RETURNS - FOR SERVICE

ALL SMITH & WESSON FIREARMS

Smith & Wesson

2100 Roosevelt Avenue

Springfield, MA 01104

- Should your Smith & Wesson® firearm require service, it should be returned to the Smith & Wesson® factory.
- Call or e-mail the Customer Service Dept. for authorization and shipping instructions.
- Ensure that the firearm is unloaded.
- Do not attempt to ship a firearm via US Postal Service; only federally licensed dealers may ship a firearm by US Postal Service.
- **DO NOT SHIP ANY AMMUNITION.**
- Enclose a letter which includes your full name and address (no P.O. Boxes, please), daytime telephone number, e-mail address, the serial number of the firearm, and details of the problem experienced (stating the brand and type of ammunition used when the problem occurred) or work desired.

CONTACT & SHIPPING INFORMATION - CONTINUED

- Record the serial number before shipping, in case you wish to check on the repair status of your firearm.
- Please remove all custom parts and accessories, such as stocks, special sights and scopes, or slings from your firearm before returning.
- Place the firearm in its original case or in a similarly secure container and pack it securely.
- The package must NOT bear any markings which indicate the identity of the contents.
- It is important that you comply with federal, state, and local laws and regulations. The following guidelines are meant to help, but you must seek assistance from the appropriate authorities if necessary.
- If your firearm must be replaced, it may be necessary to ship the replacement to a dealer rather than directly to you. You will be requested to furnish a signed FFL (Federal Firearms License) from your dealer in such an instance.
- Warranty repair work will begin upon receipt and examination of the firearm. In the case of repairs or work not covered by the warranty, a quotation covering the cost of the work plus round-trip transportation charges will be sent to you. Repairs or modification will be scheduled upon receipt of payment.

 **WARNING: YOU MAY PURCHASE ACCESSORIES FOR YOUR SMITH & WESSON FIREARM. NEVER MODIFY OR SWAP OUT ANY OF THE COMPONENTS OF YOUR SMITH & WESSON® FIREARM, UNLESS SPECIFICALLY INSTRUCTED TO DO SO IN THIS MANUAL OR IN AN OFFICIAL SMITH & WESSON ACCESSORY PARTS MANUAL OR INSTRUCTION SHEET. CHANGES NOT COVERED IN THIS MANUAL OR IN A SMITH & WESSON INSTRUCTION SHEET WILL REQUIRE A QUALIFIED GUNSMITH (OR FACTORY-TRAINED PERSONNEL) USING FACTORY-AUTHORIZED PARTS. IMPROPER MANIPULATION OF ANY COMPONENT OF THE FIREARM MAY RESULT IN FAULTY FUNCTIONING, POSSIBLY LEADING TO INJURY OR DEATH OF THE SHOOTER AND/OR BYSTANDERS AND DAMAGE TO PROPERTY.**

SOME PARTS MUST BE INSTALLED BY A GUNSMITH QUALIFIED TO PERFORM SERVICE ON SMITH & WESSON® FIREARMS, EVEN IF THE ALTERATION SEEMS SIMPLE.

BATTERY WARNINGS



WARNING: IF A BATTERY OPERATED ACCESSORY OR ATTACHMENT (I.E., LASER, OPTICAL SIGHT OR FLASHLIGHT, ETC.) IS SUPPLIED OR USED WITH THIS FIREARM, THE FOLLOWING WARNINGS AND INSTRUCTIONS MUST BE ADHERED TO.



WARNING: KEEP BATTERIES AWAY FROM CHILDREN. THERE IS A CHEMICAL BURN HAZARD ASSOCIATED WITH BATTERIES.



WARNING: IF A NEW OR USED LITHIUM BUTTON/COIN CELL BATTERY IS SWALLOWED OR ENTERS THE BODY, IT CAN CAUSE SEVERE INTERNAL BURNS AND CAN LEAD TO DEATH IN AS LITTLE AS 2 HOURS. ALWAYS COMPLETELY SECURE THE BATTERY COMPARTMENT. IF THE BATTERY COMPARTMENT DOES NOT CLOSE SECURELY, STOP USING THE PRODUCT, REMOVE THE BATTERIES, AND KEEP IT AWAY FROM CHILDREN. IF YOU THINK BATTERIES MIGHT HAVE BEEN SWALLOWED OR PLACED INSIDE ANY PART OF THE BODY, SEEK IMMEDIATE MEDICAL ATTENTION.

- When used correctly, batteries provide a safe and dependable source of portable power. However, misuse or abuse may result in leakage, fire, or explosion.
- Batteries can explode or leak and cause burns if installed backwards, disassembled, charged, or exposed to water, fire or high temperature.
- Always take care to install your batteries correctly observing the “+” and “-” marks on the battery and the device.
- Always replace the whole set of batteries at one time, taking care not to mix old and new batteries, or batteries of different types.
- Store unused batteries in their original packaging and away from metal objects that may short-circuit them.
- Remove discharged batteries from equipment promptly to avoid possible damage from leakage.
- Never dispose of batteries in fire. Failure to observe this precaution may result in an explosion.
- The batteries are supplied in a charged state and are not designed for recharging. Recharging may cause leakage, fire, or explosion.
- The batteries should be disposed of properly, including keeping them away from children.
- Dispose of used batteries immediately. Even used batteries may cause injury.

CUSTOM SERVICE

We understand that Smith & Wesson® gun owners may want to enhance their guns with custom gunsmithing, refinishing or accessories. Our gunsmiths offer specialized services and exclusive products to enhance your shooting experience.

Accessories for your Smith & Wesson® firearm are available from your local S&W Authorized Dealer, or directly from Smith & Wesson®. Contact the Customer Service Department at 1-800-331-0852, extension 4125 for information about these services.

When ordering directly from the factory, please provide the following:

- Model Number
- Serial Number
- Return Address
- VISA/Discover/MasterCard Number & Expiration Date
- For Foreign Orders Only, Fax Number or E-mail Address
- Dash Number
- Approximate date of purchase

PATENT INFORMATION

- This product may be covered by one or more patents. Visit <https://www.smith-wesson.com/company/virtual-patent-marking> for virtual patent information.



Smith & Wesson®

EMPOWERING AMERICANS™



3015918

SMITH & WESSON®

1852 Proffitt Springs Rd., Maryville, TN 37801

1-800-331-0852 • Fax: 1-413-747-3317

www.smith-wesson.com

p/n 3015918

REV:S&W_MODEL-1854-120523