

ESCRITORIO BÁSICO

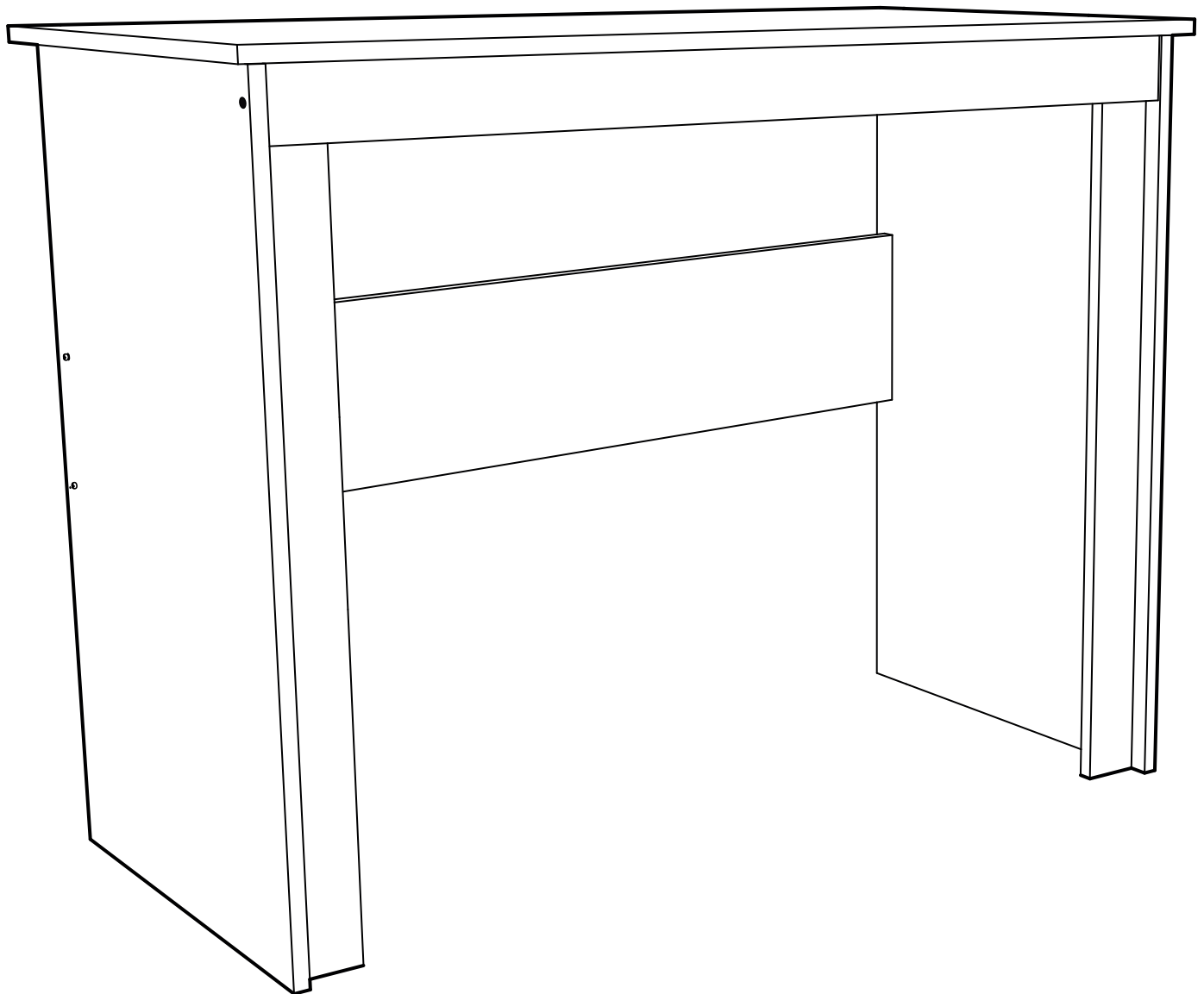

Encuentre su instructivo de armado:

- 1- Ingrese a www.cic.cl
- 2- Busque el nombre del mueble.
- 3- Haga click sobre el mueble seleccionado.
- 4- Diríjase a la opción "ARMALO TU MISMO"
- 5- Descargue el manual de armado.

o escanée el siguiente código QR.



HERRAMIENTAS

A USAR • NO INCLUIDAS

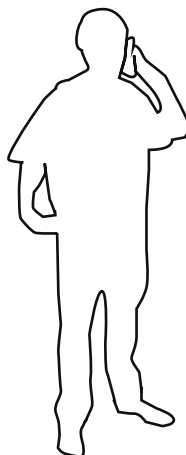
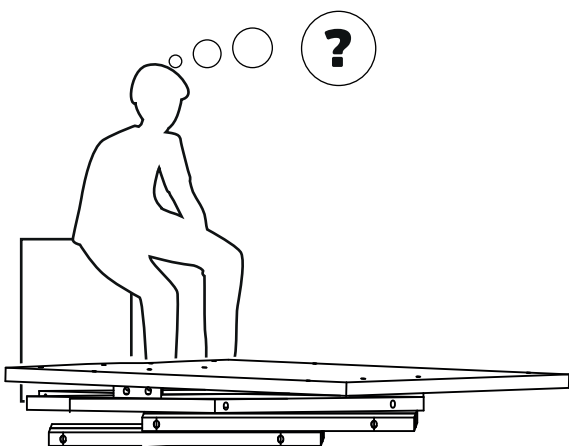

SERVICIO AL CLIENTE
800 74 00 00

INDICA TAPANCANTO

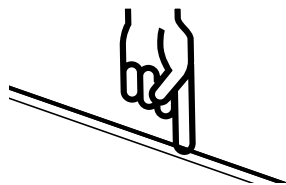

1 - Revise que todos los herrajes contenidos en la(s) bolsa(s) coincidan con el listado de herrajes indicado en las siguientes páginas.

2- No elimine ningún número de las piezas. Una vez armado el mueble puede desprenderlos y/o borrarlos (los números impresos puede borrarlos con alcohol, alcohol gel o desinfectante de ambientes)

3 -Revise que todos los herrajes de la(s) bolsa(s) coincidan con el listado que aparece en este instructivo (tipo de herraje y cantidad)

4- No retire el número que va pegado en el exterior de la caja. Este número se denomina código de trazabilidad (ej.: 0871265) y tiene por objetivo hacer el seguimiento al mueble, en caso de que se presenten problemas en el armado.



PIEZAS Y COMPONENTES

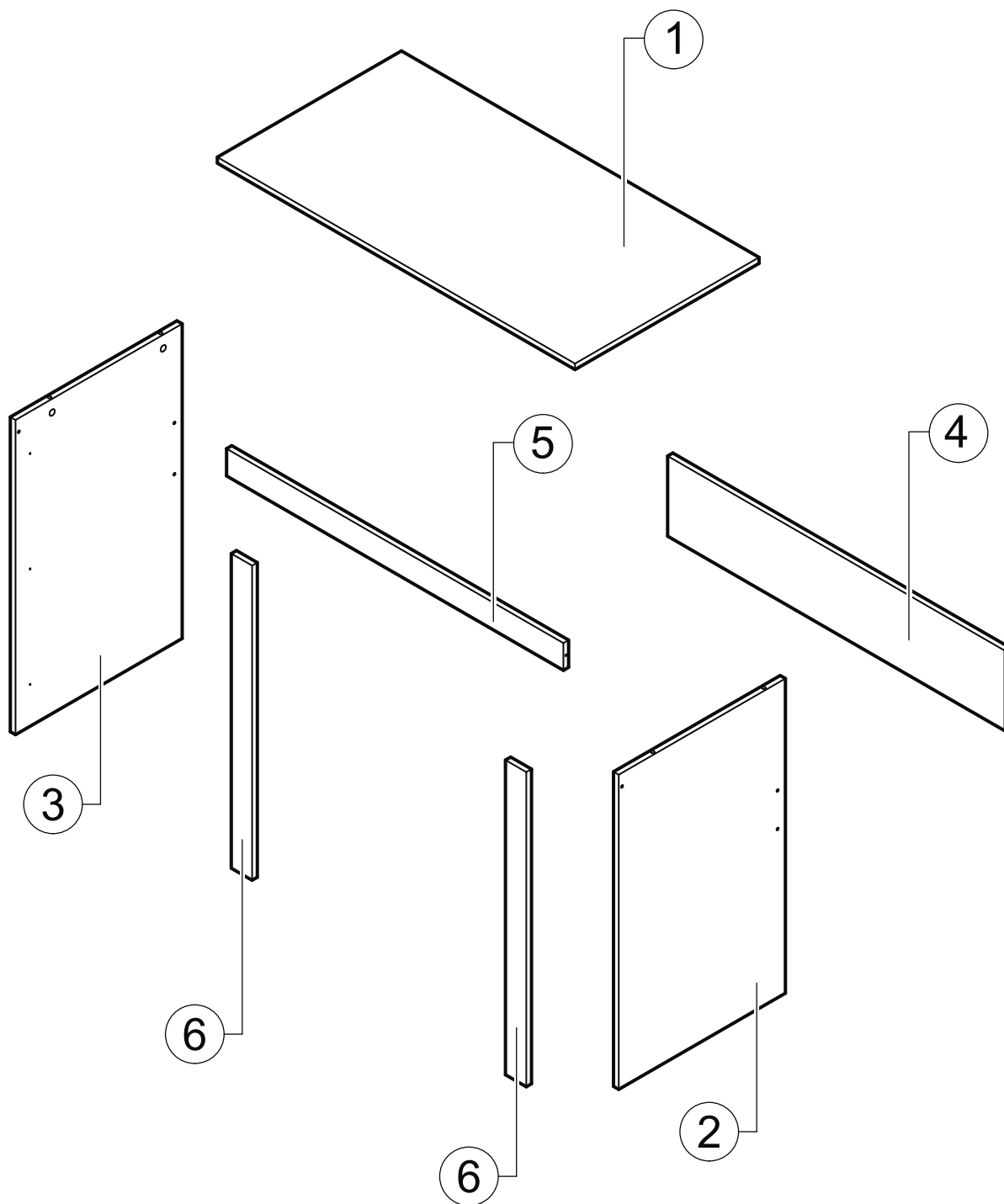

1	CUBIERTA	x1
2	COSTADO DERECHO	x1
3	COSTADO IZQUIERDO	x1
4	FALDÓN	x1
5	BARRA HORIZONTAL	x1
6	BARRA VERTICAL	x2



HERRAJES



E x16



x4

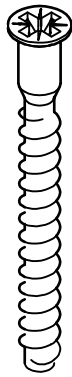

M x6



x4

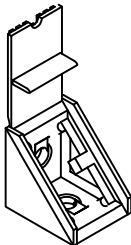

x8



x6



PREPARACIÓN DE PIEZAS

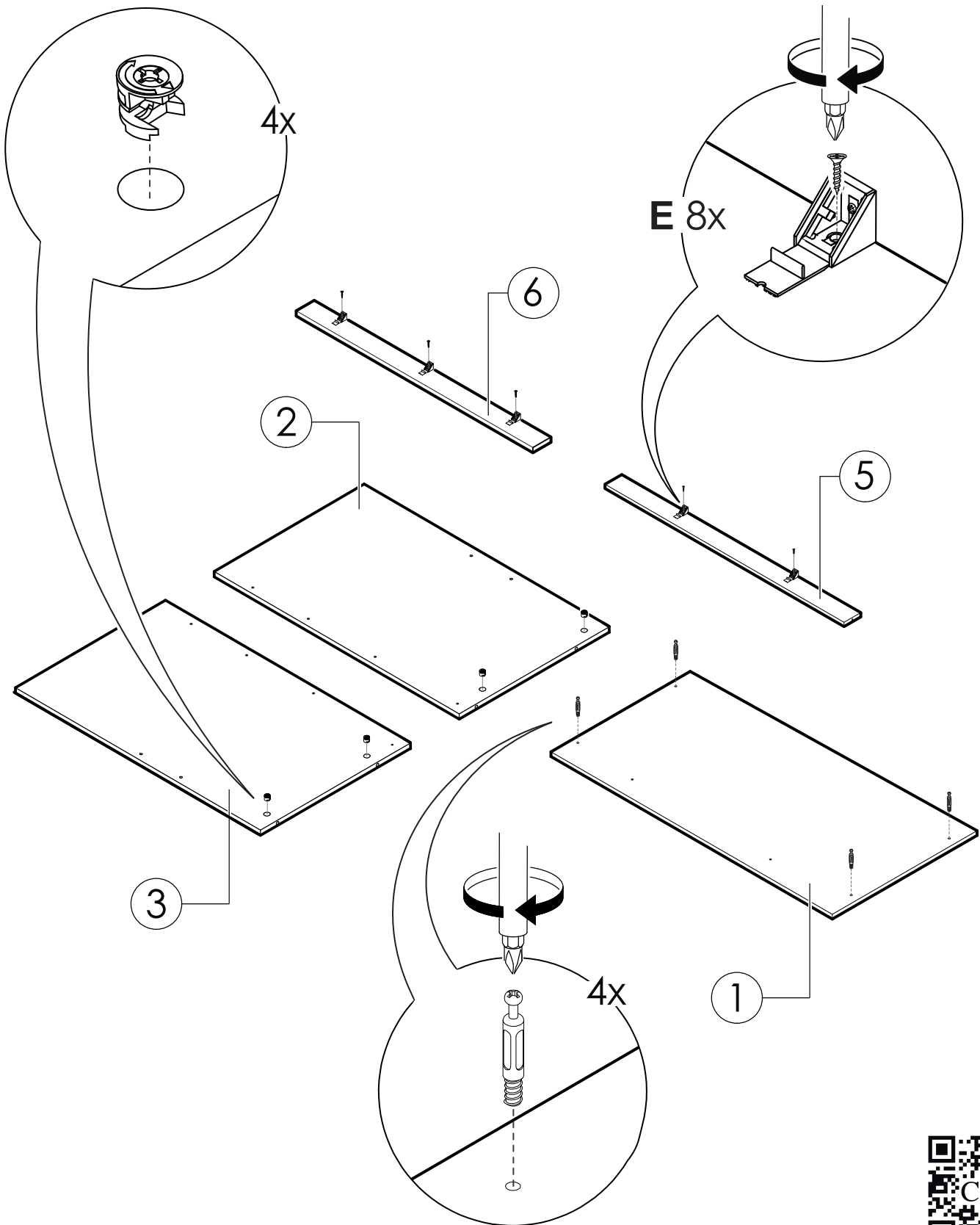

1

SECUENCIA DE ARMADO

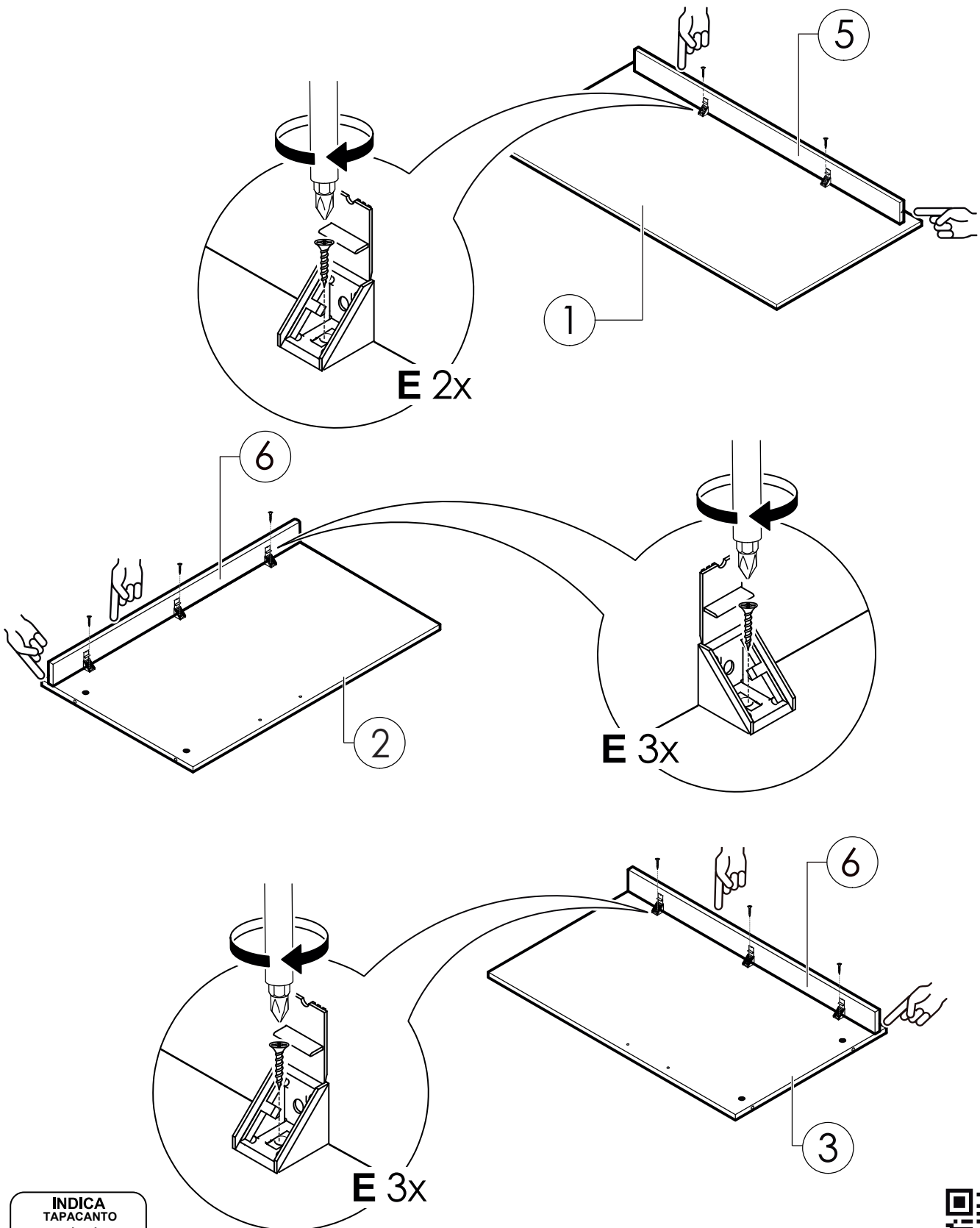

2

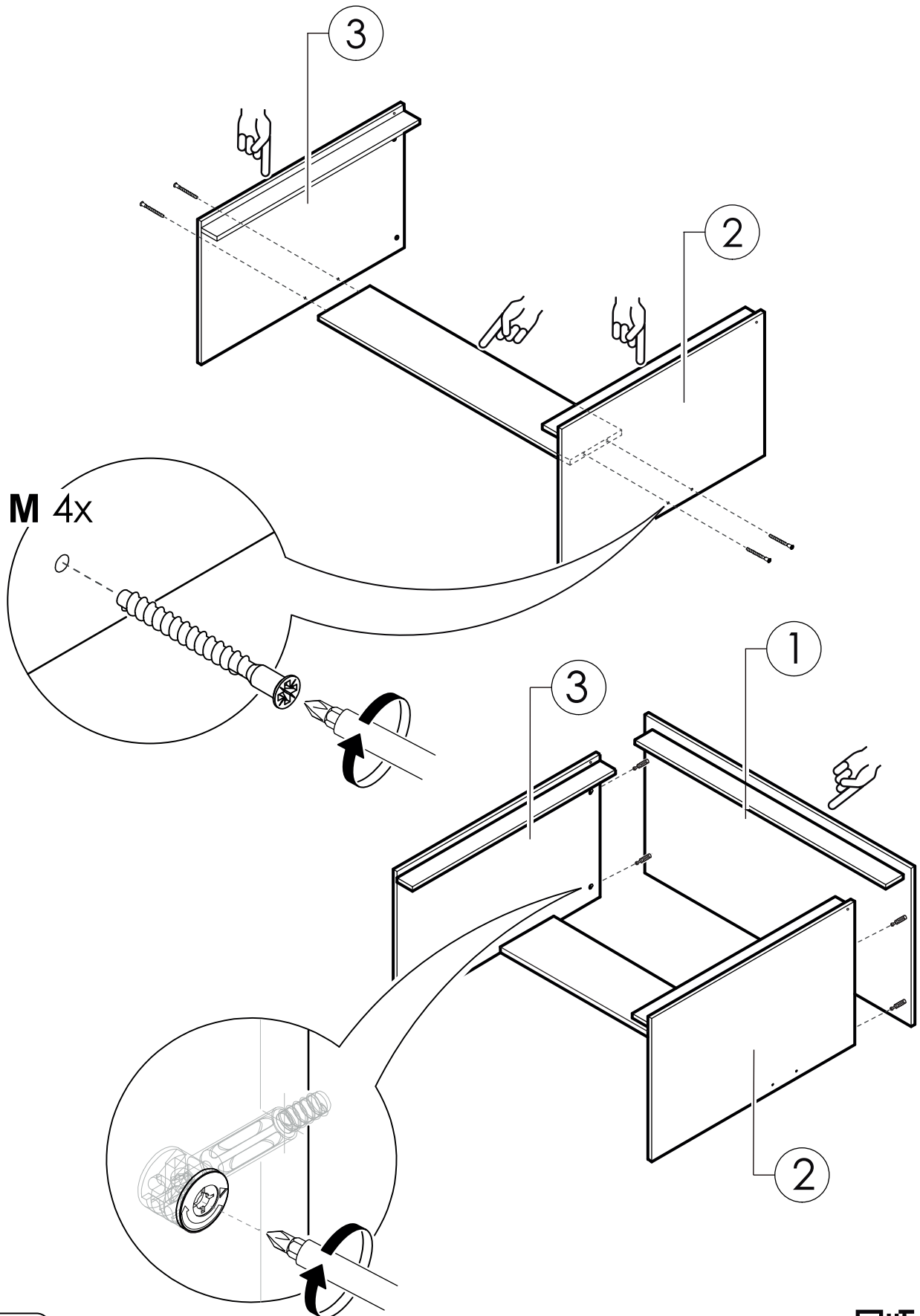

3

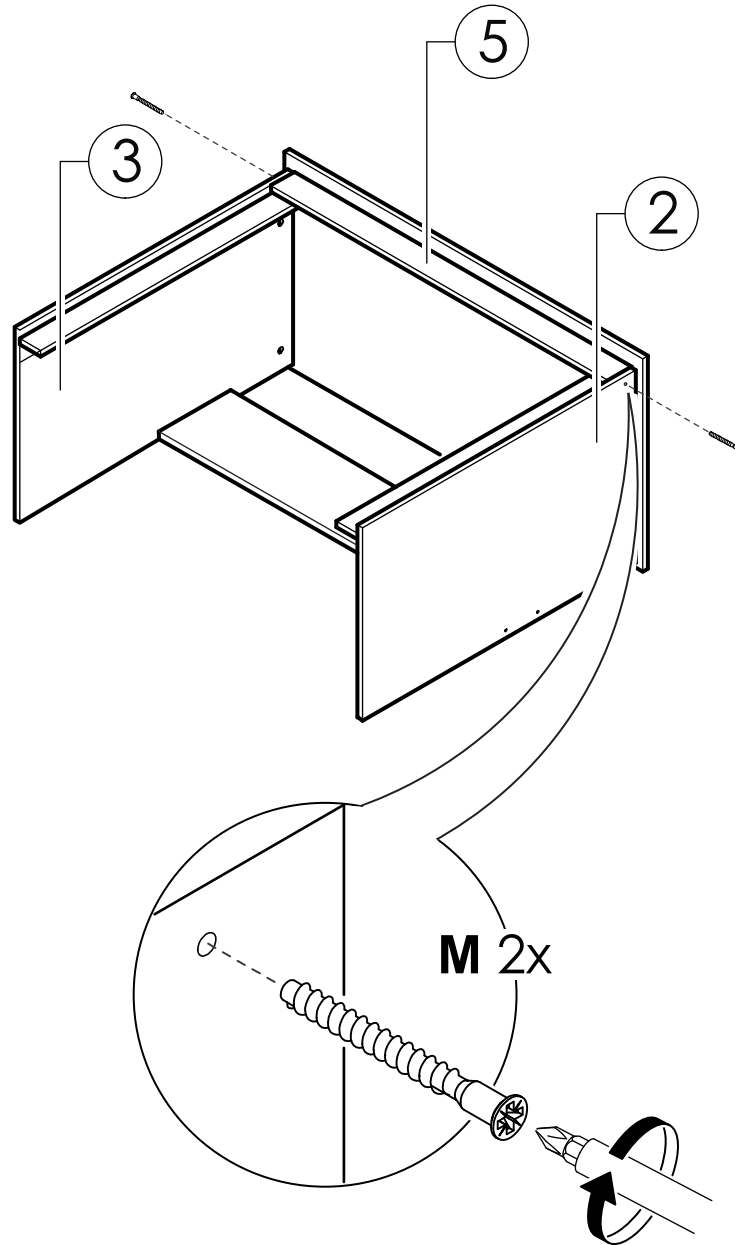

4

