

CLOSET MAULE

4 PUERTAS CORREDERAS - 8 CAJONES



Encuentre su instructivo de armado:

- 1- Ingrese a www.cic.cl
- 2- Busque el nombre del mueble.
- 3- Haga click sobre el mueble seleccionado.
- 4- Diríjase a la opción "ARMALO TU MISMO"
- 5- Descargue el manual de armado.

o escanee el siguiente código QR.



HERRAMIENTAS

A USAR • NO INCLUIDAS

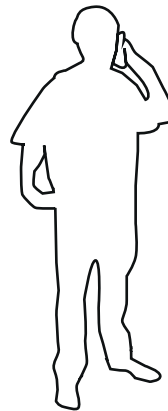
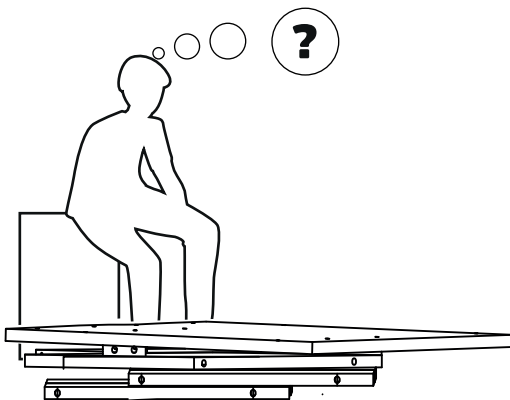
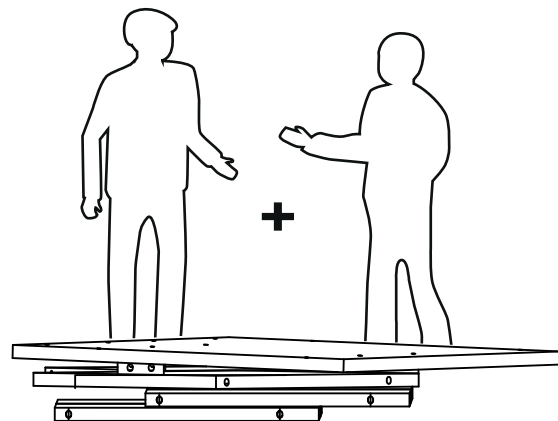
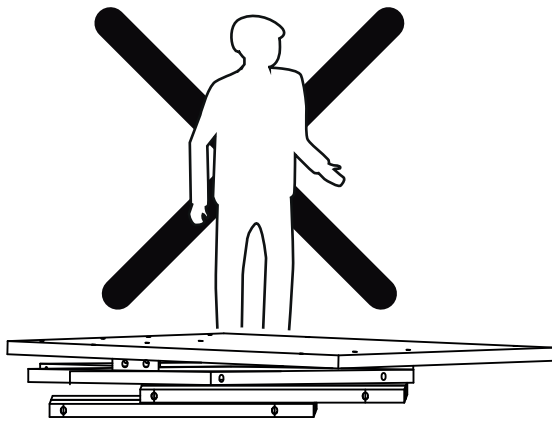
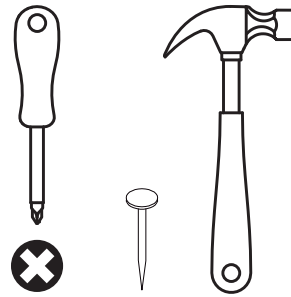

SERVICIO AL CLIENTE
800 74 00 00

INDICA TAPANCANTO

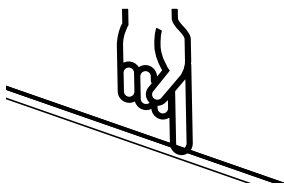

- 1 - Revise que todos los herrajes contenidos en la(s) bolsa(s) coincidan con el listado de herrajes indicado en las siguientes páginas.
- 2- No elimine ningún número de las piezas. Una vez armado el mueble puede desprenderlos y/o borrarlos (los números impresos puede borrarlos con alcohol, alcohol gel o desinfectante de ambientes)
- 3 -Revise que todos los herrajes de la(s) bolsa(s) coincidan con el listado que aparece en este instructivo (tipo de herraje y cantidad)
- 4- No retire el número que va pegado en el exterior de la caja. Este número se denomina código de trazabilidad (ej.: 0871265) y tiene por objetivo hacer el seguimiento al mueble, en caso de que se presenten problemas en el armado.

PIEZAS Y COMPONENTES

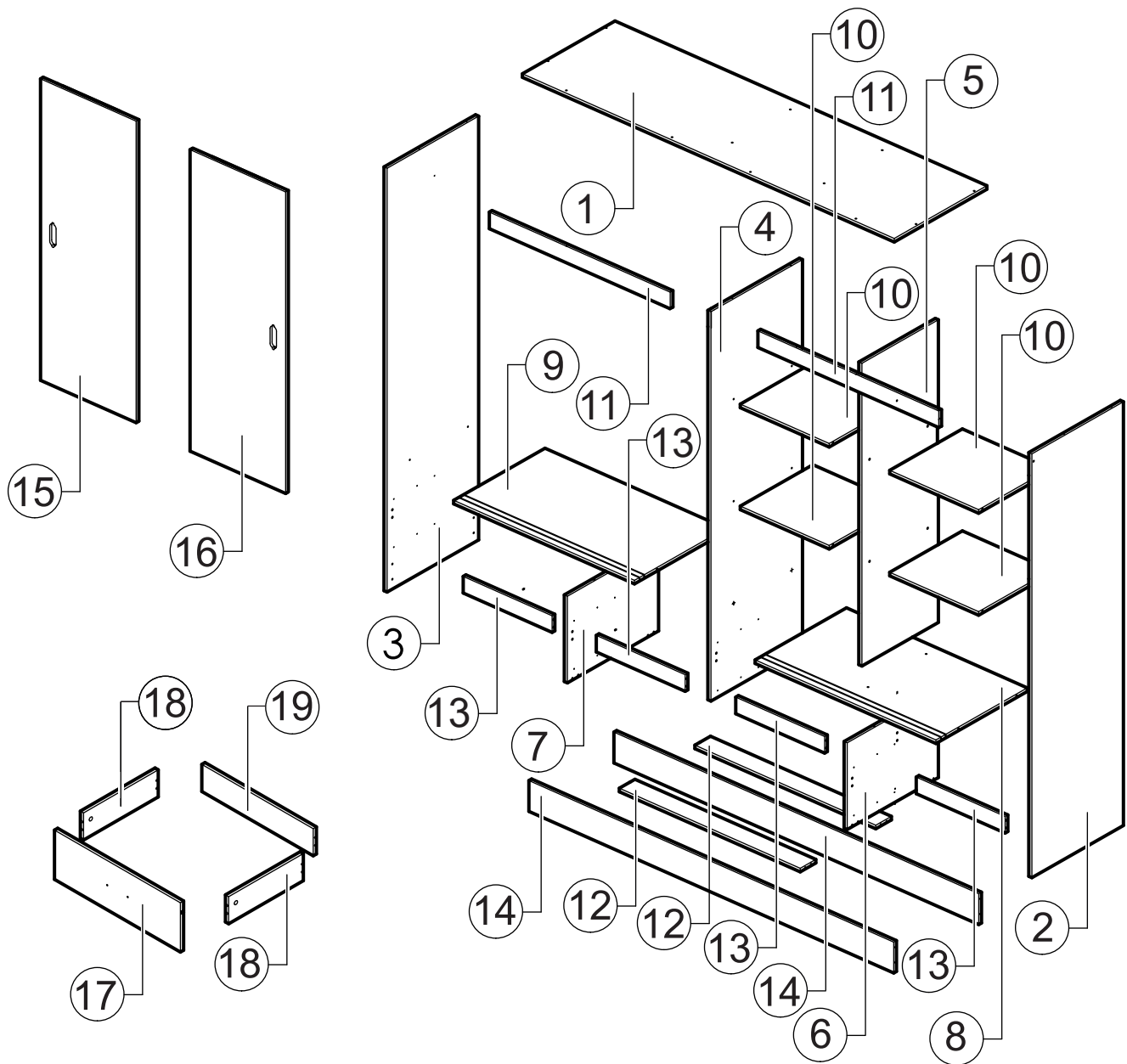

1	CUBIERTA	x1
2	COSTADO DERECHO	x1
3	COSTADO IZQUIERDO	x1
4	COSTADO CENTRAL	x1
5	COSTADO INTERIOR DERECHO	x1
6	COSTADO INFERIOR CENTRAL DERECHO	x1
7	COSTADO INFERIOR CENTRAL IZQUIERDO	x1
8	REPISA SOBRE CAJON DERECHA	x1
9	REPISA SOBRE CAJON IZQUIERDA	x1
10	REPISA FIJA	x4

11	BARRA SUPERIOR	x2
12	BARRA INFERIOR	x2
13	BARRA ENTRE CAJÓN	x4
14	ZÓCALO	x2
15	PUERTA DERECHA	x2
16	PUERTA IZQUIERDA	x2
17	FRENTE CAJÓN	x8
18	COSTADO CAJÓN	x32
19	TRASERA CAJÓN	x16

HERRAJES



T x8



P x32



x32



M x64

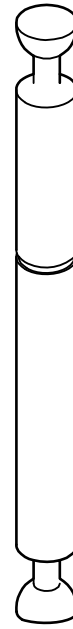

x6



E x14



x44

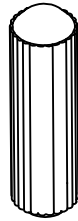

x32

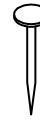

x160



C x80

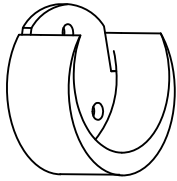

x2

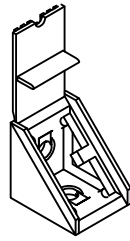

x4



x10

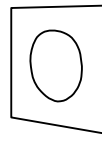

x10



x4

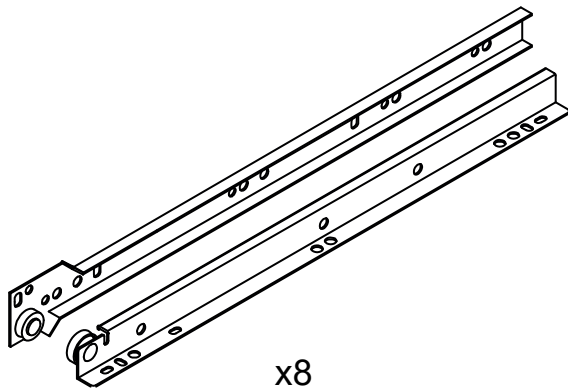

x8

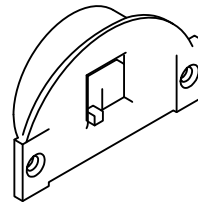

x8

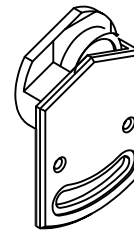

x8

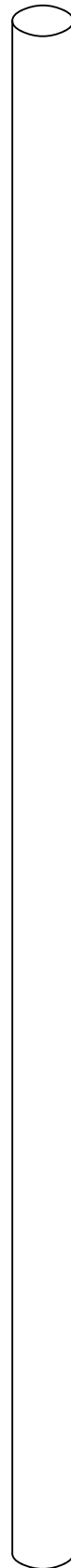

x1



x1



PREPARACIÓN DE PIEZAS

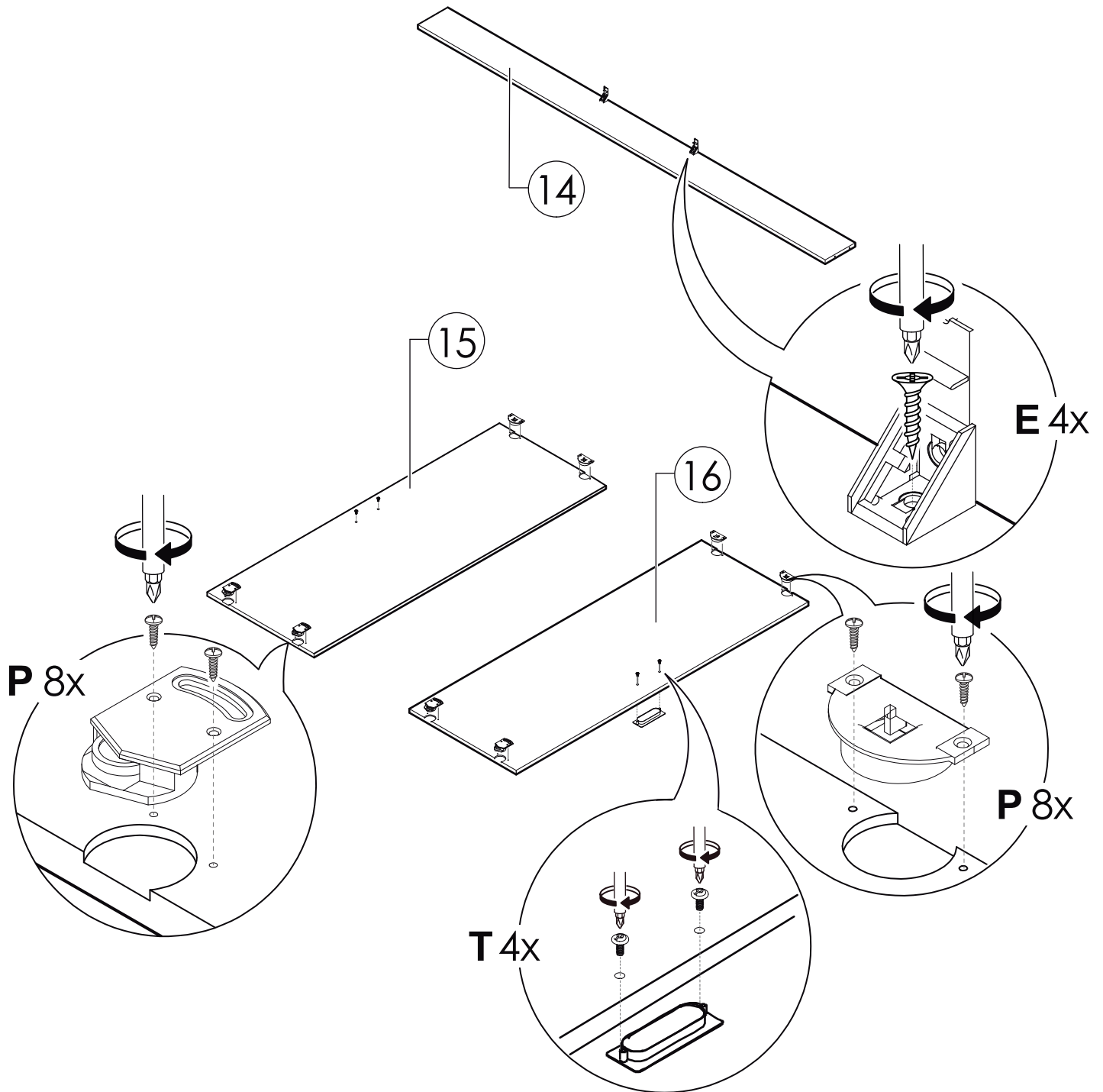

PREPARACIÓN DE PIEZAS

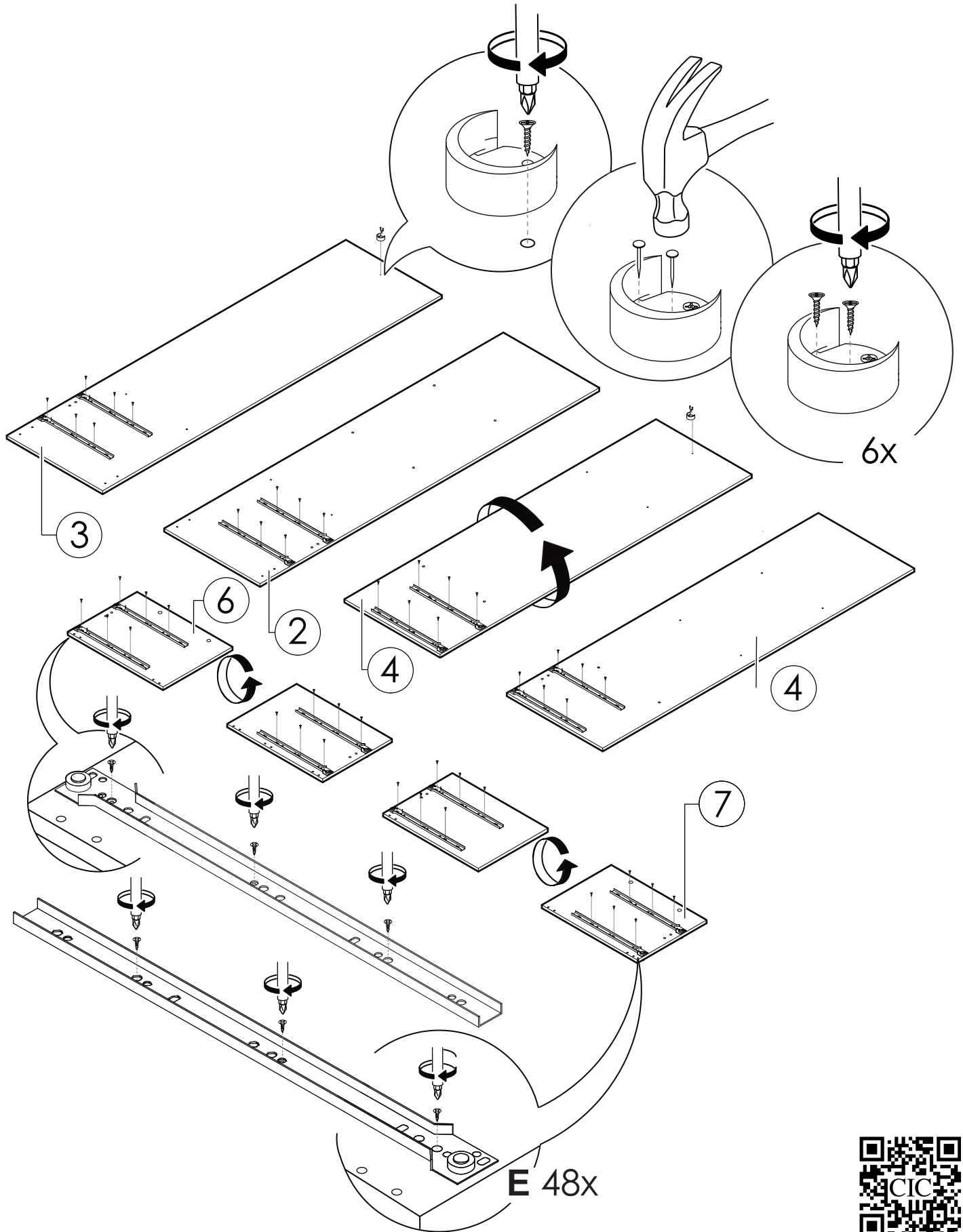

1

SECUENCIA DE ARMADO

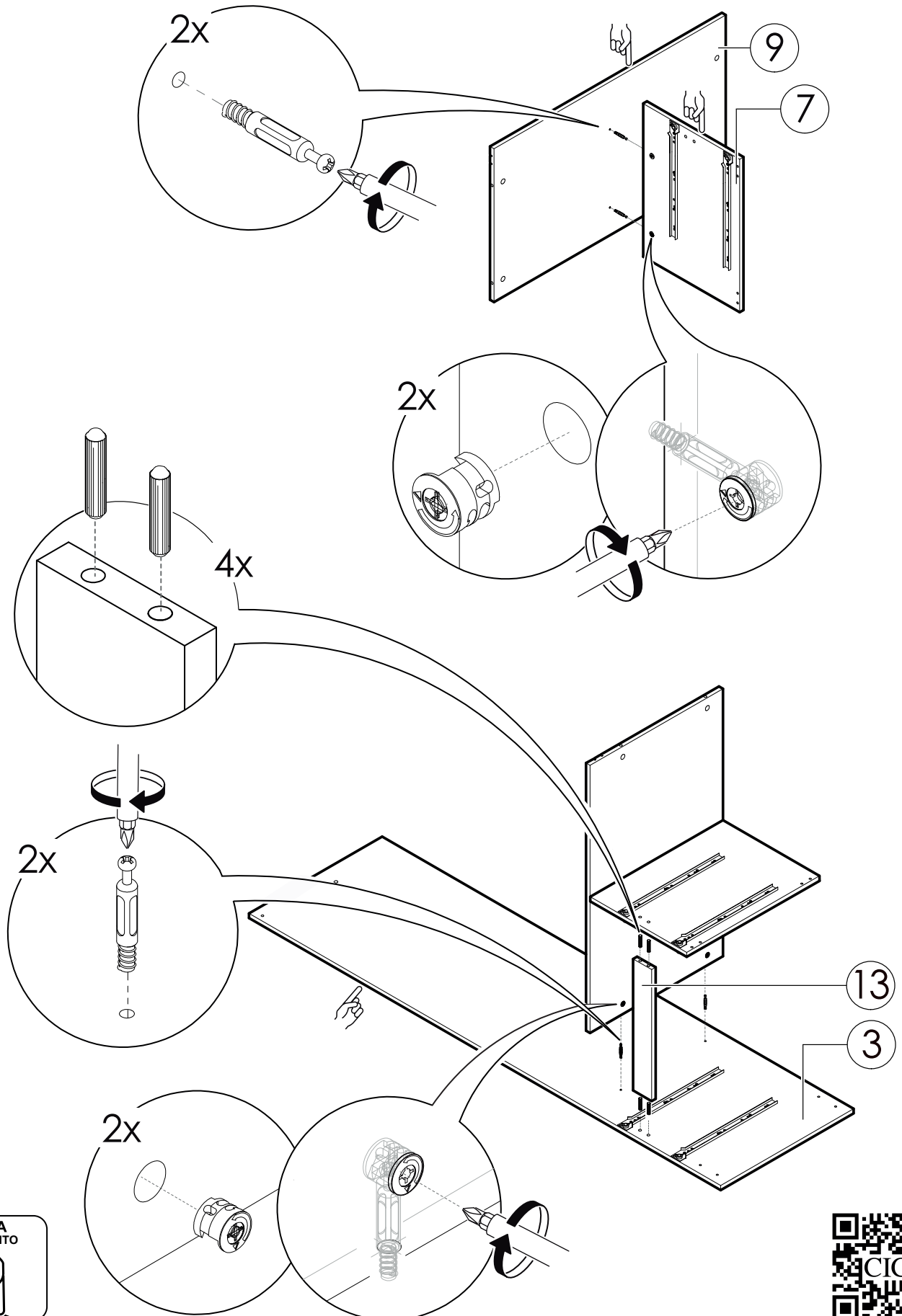

2

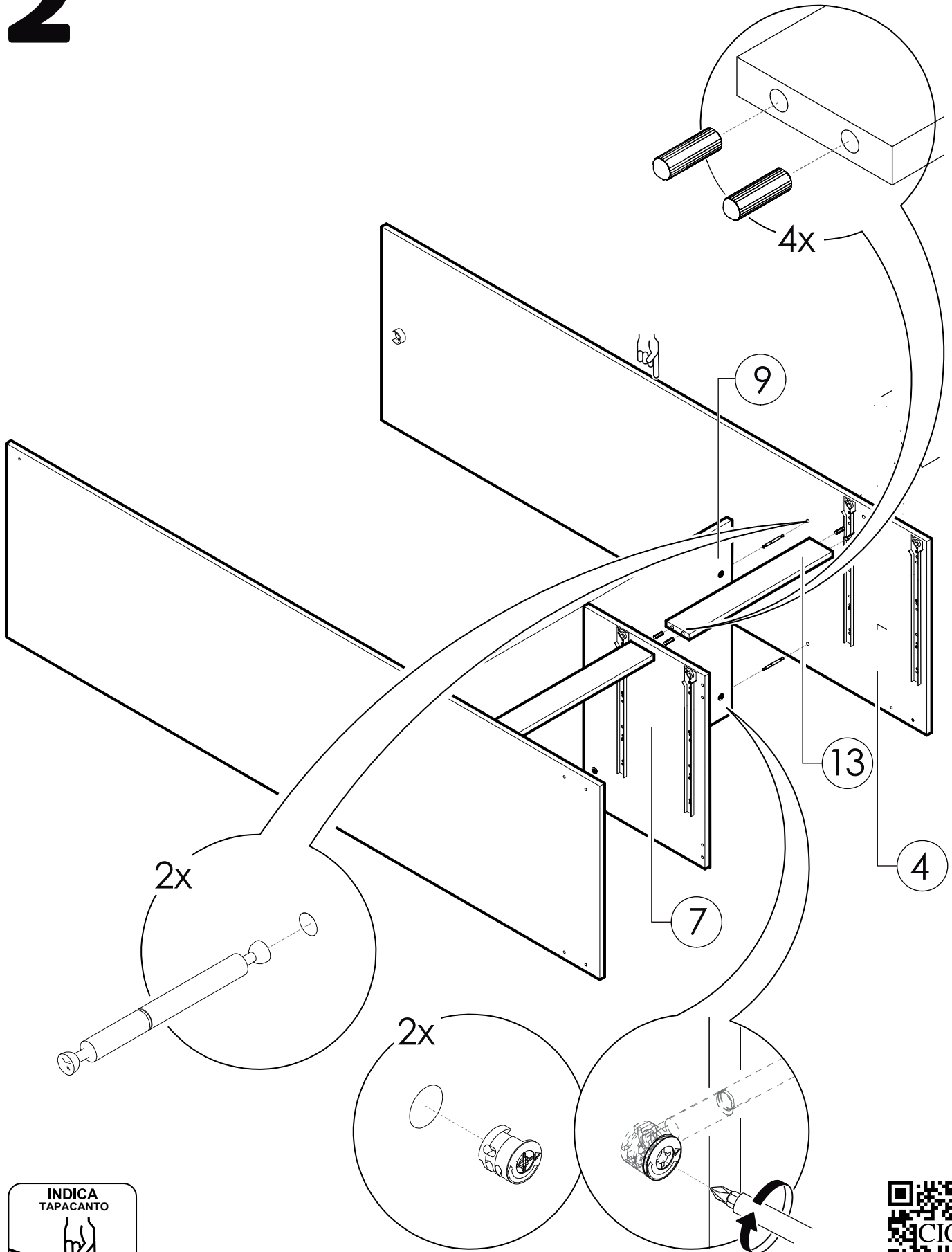

3

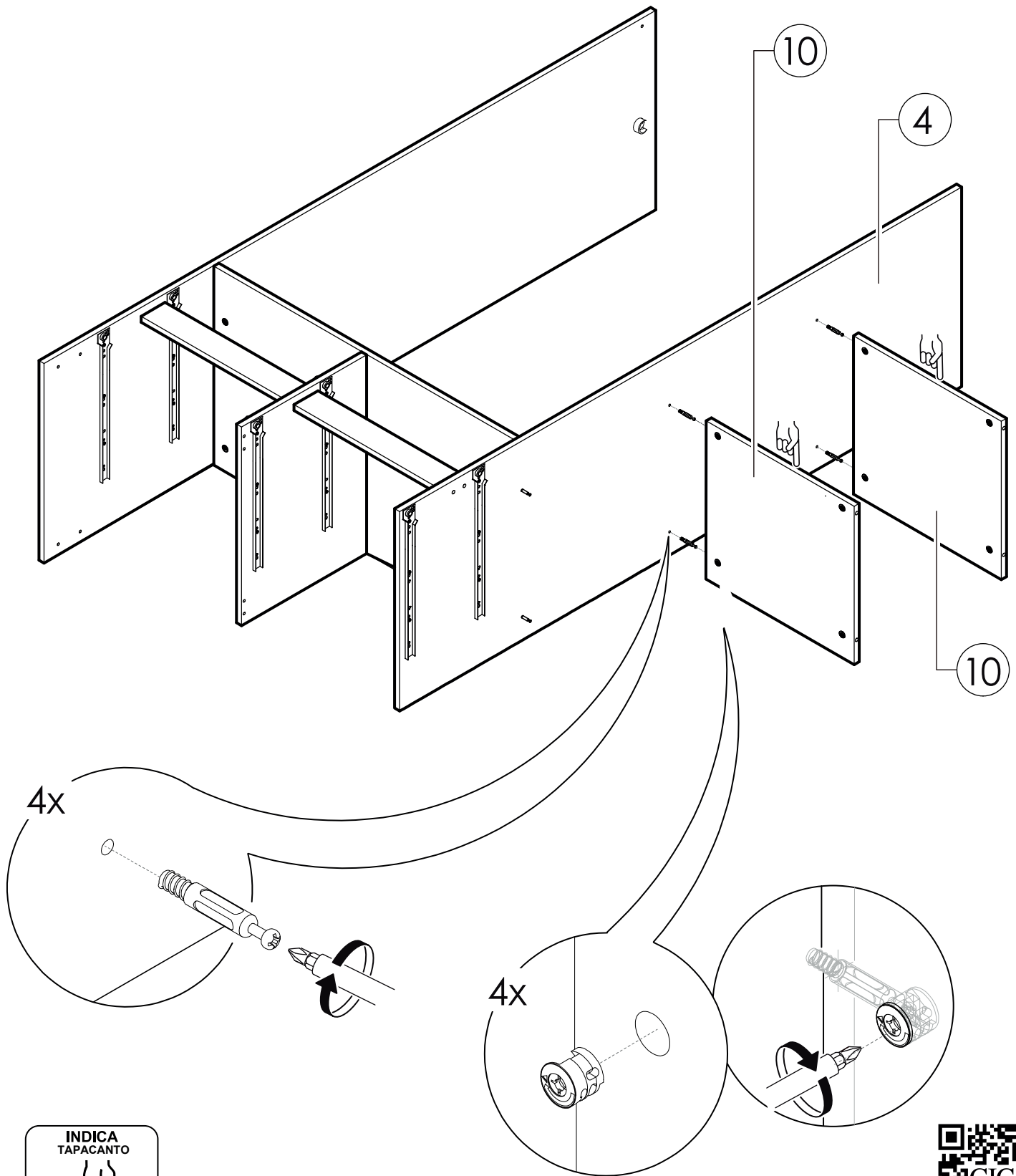

4

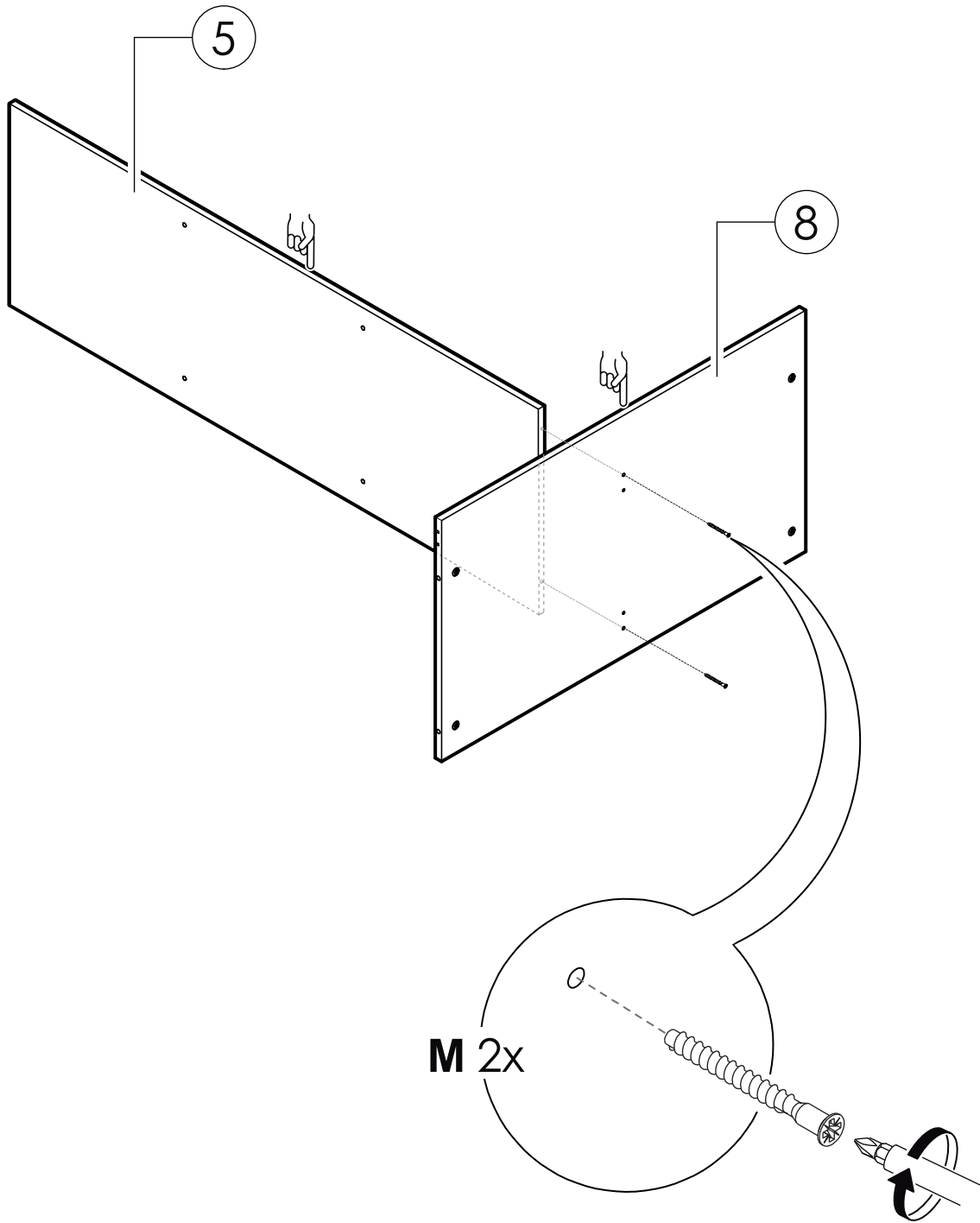

5

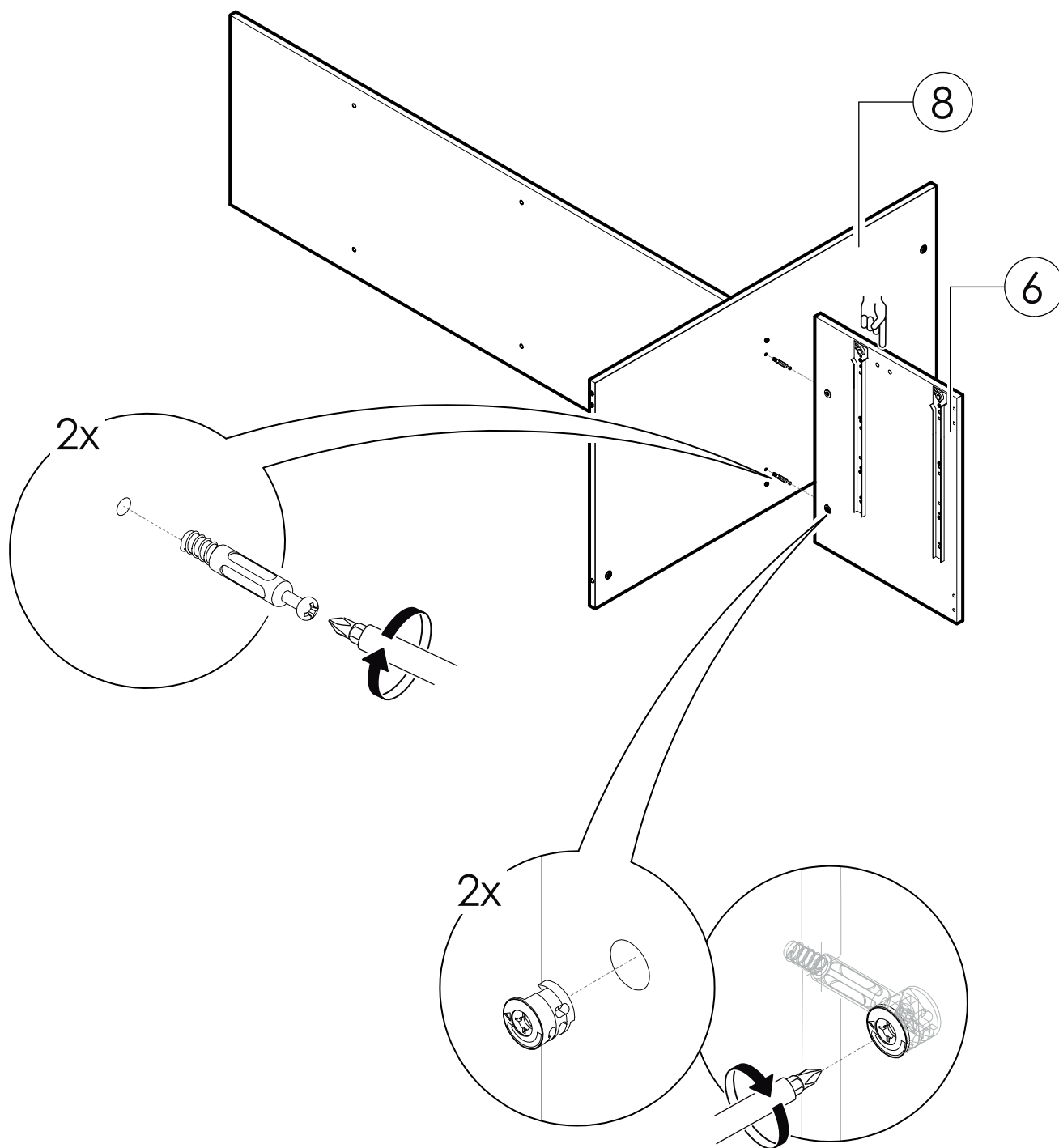

6

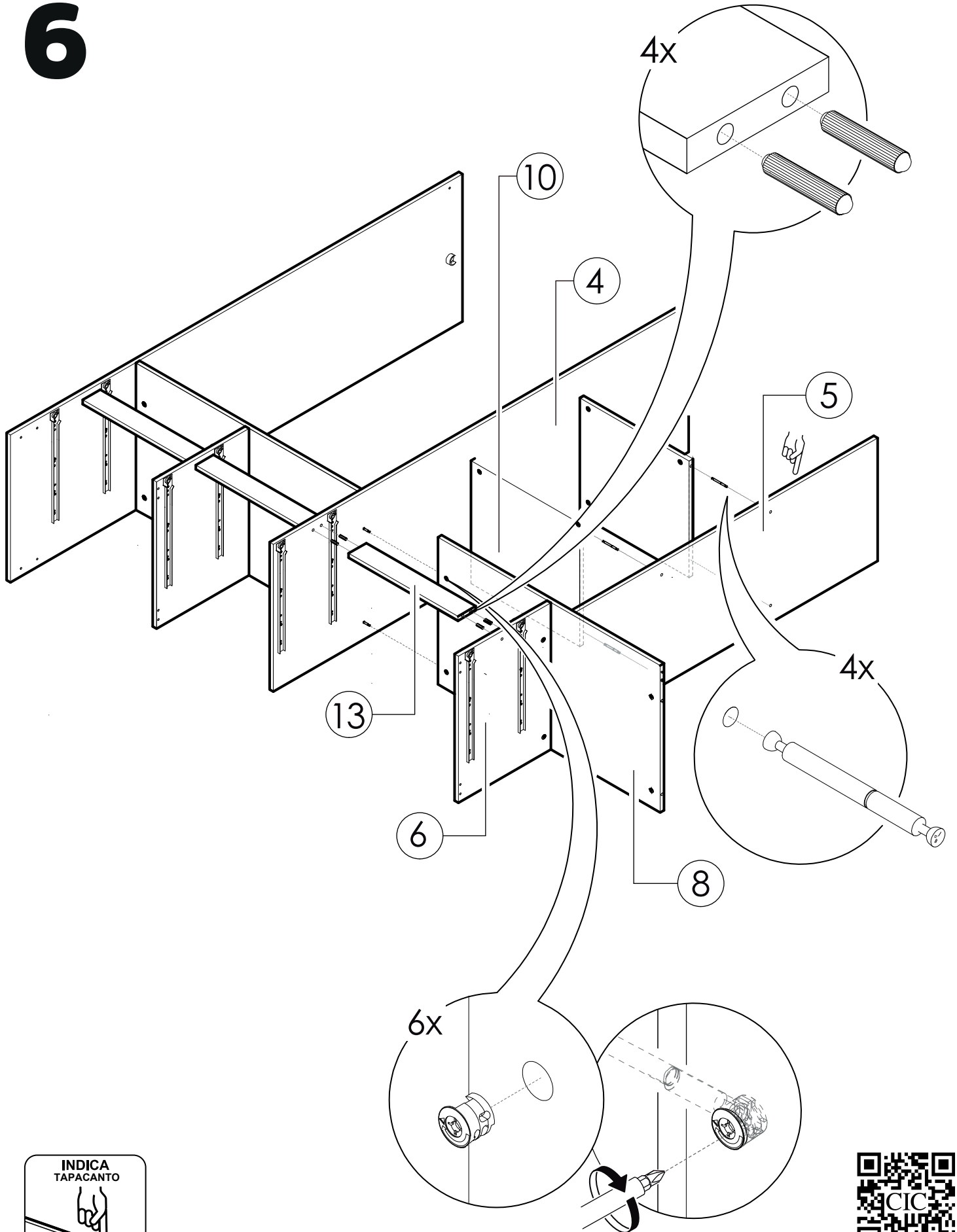

7

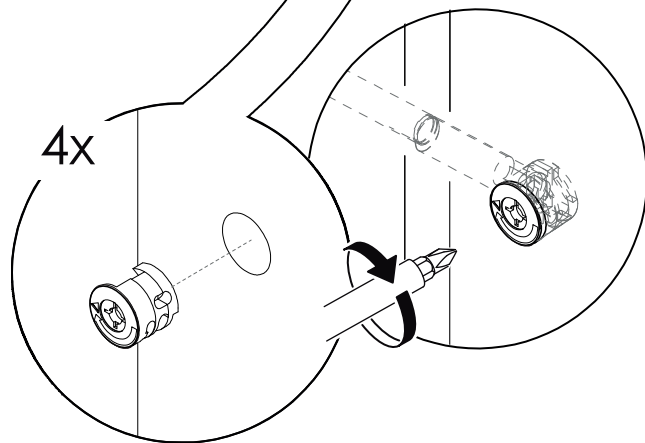
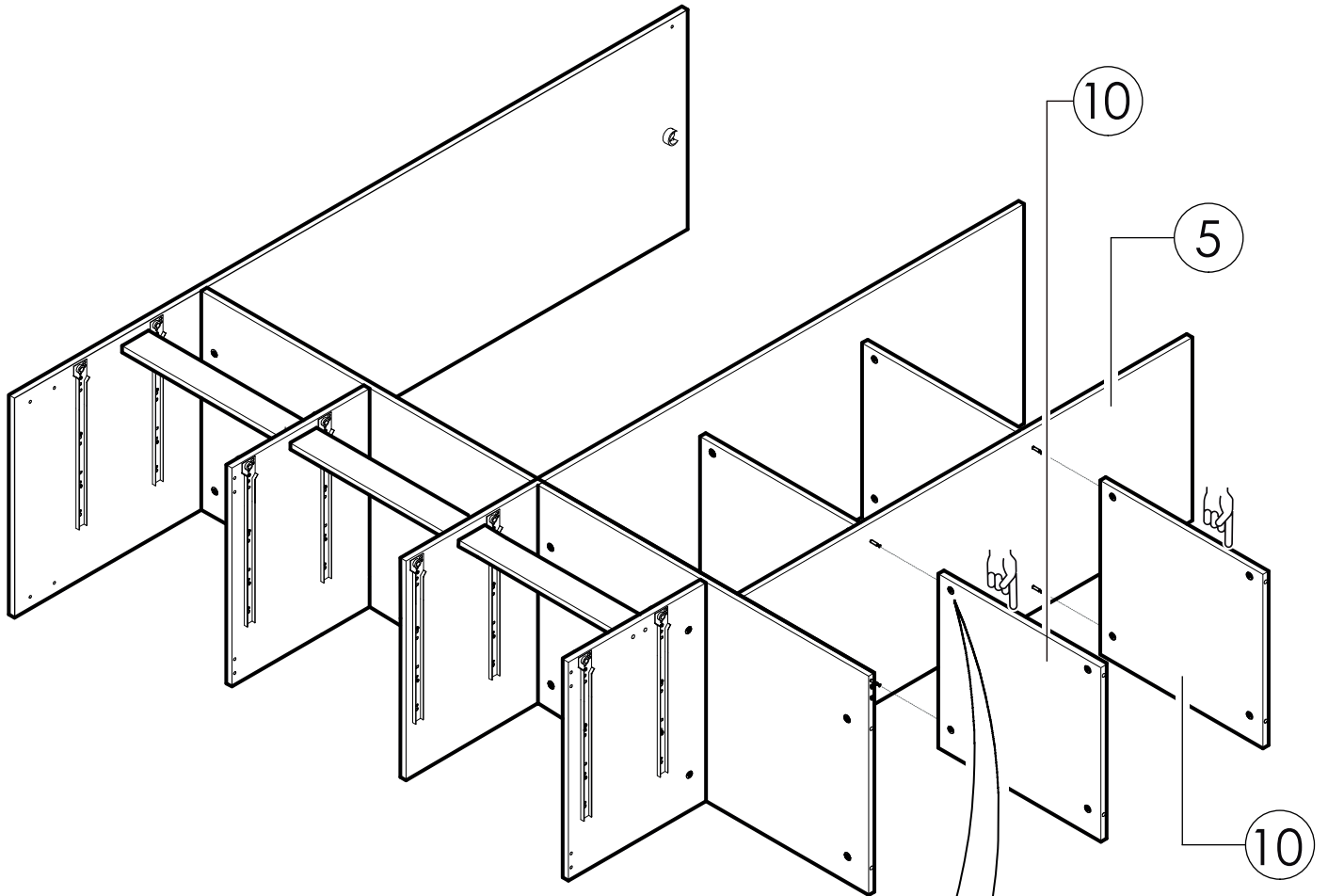

8

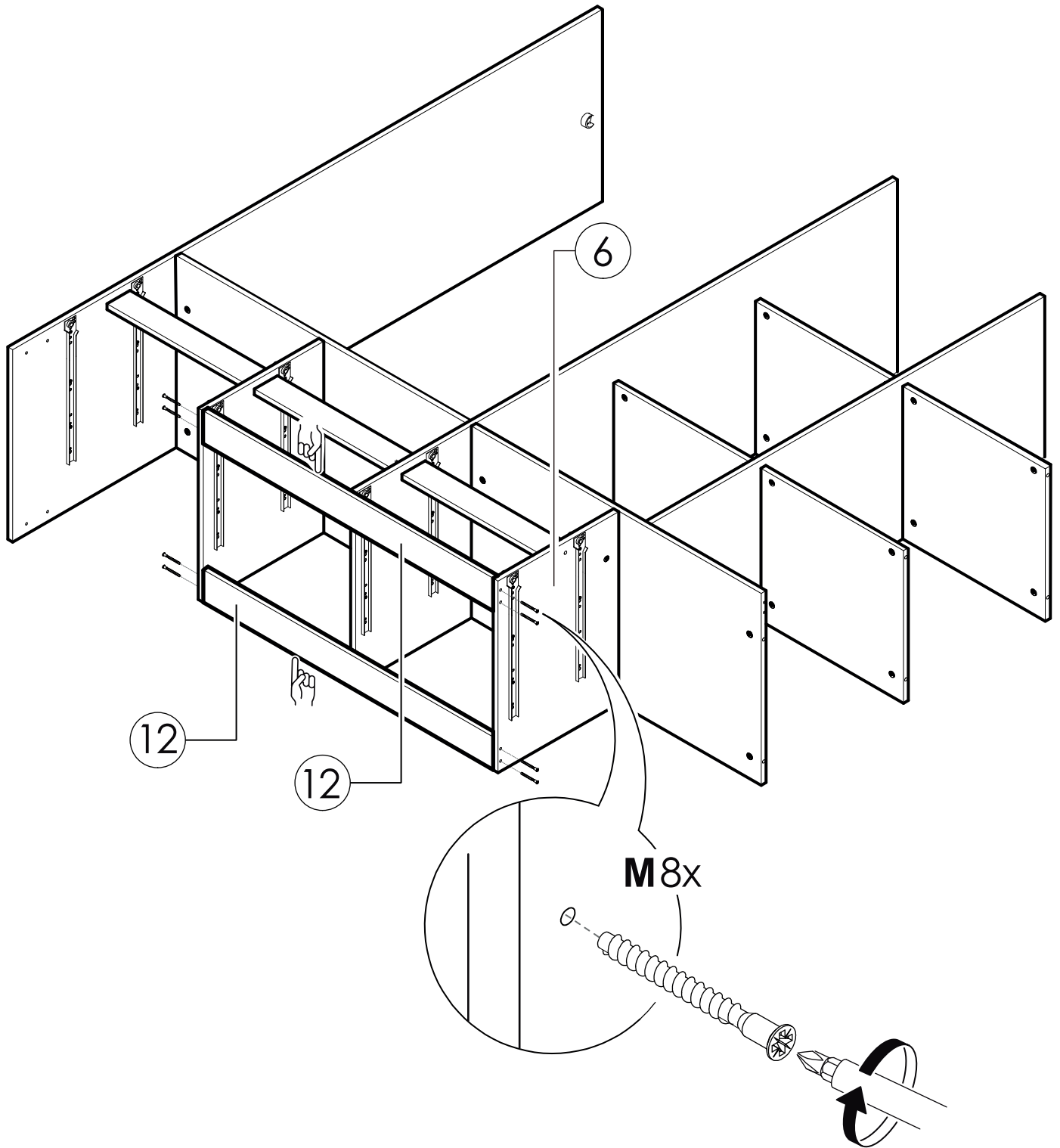

9

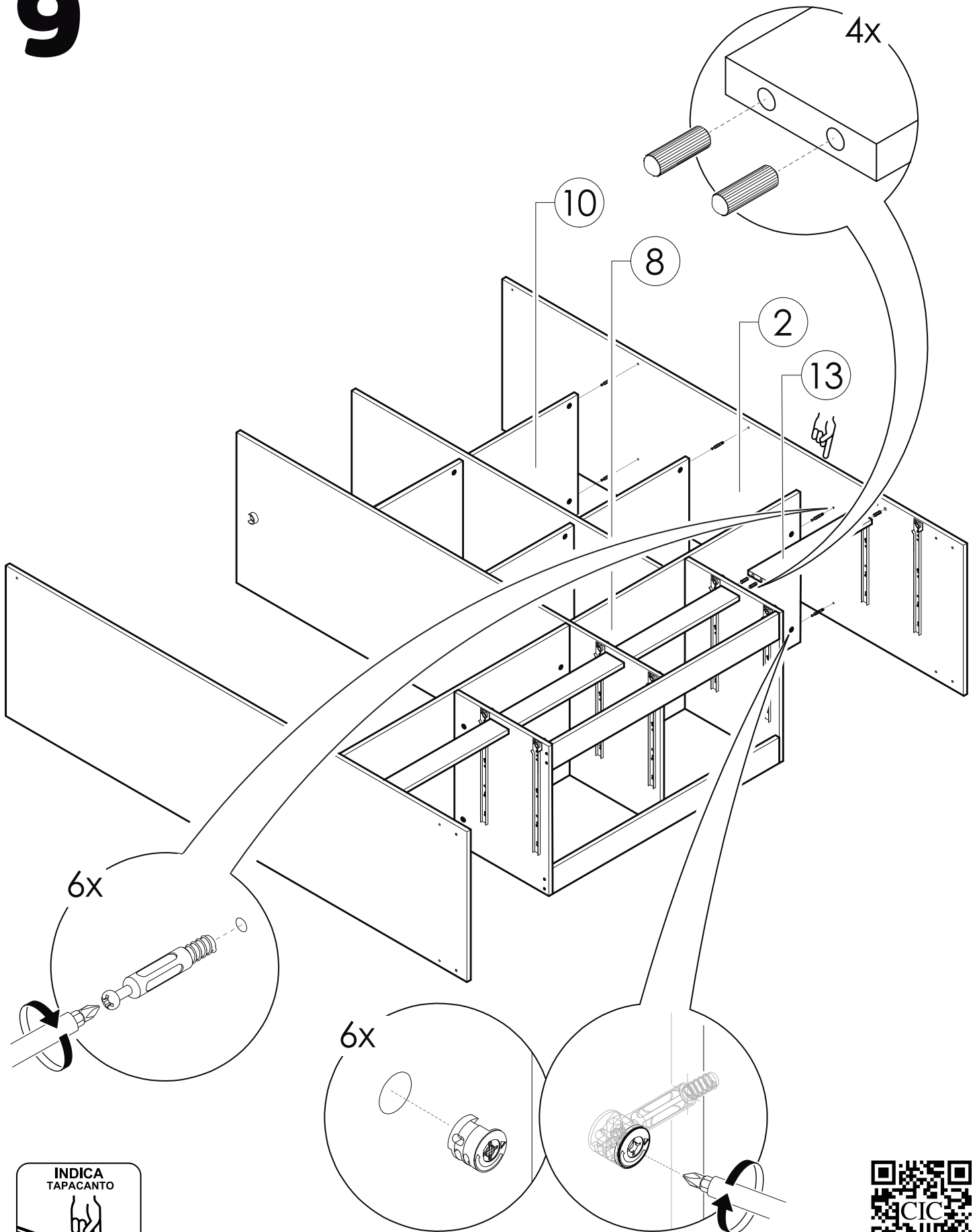

10

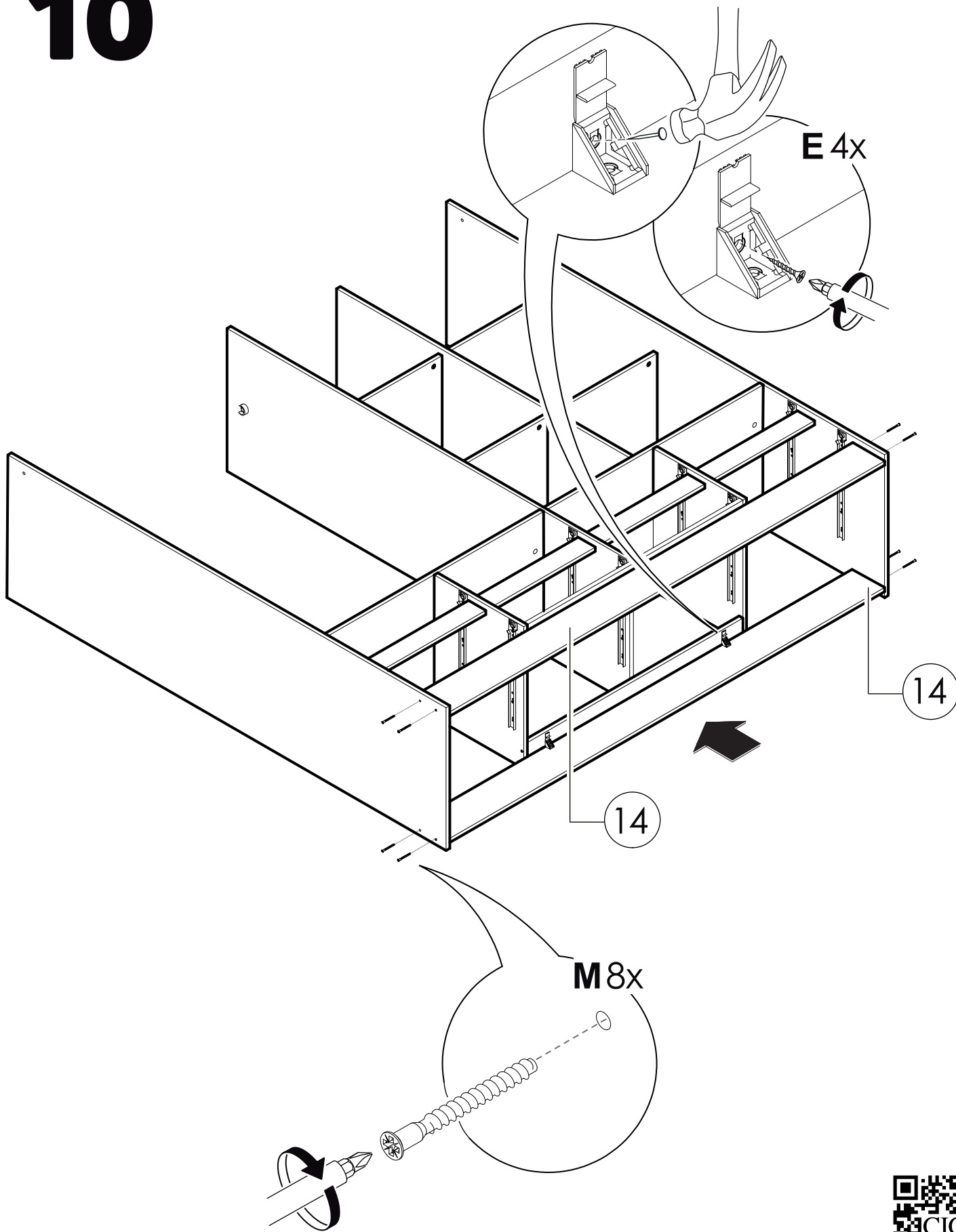

11

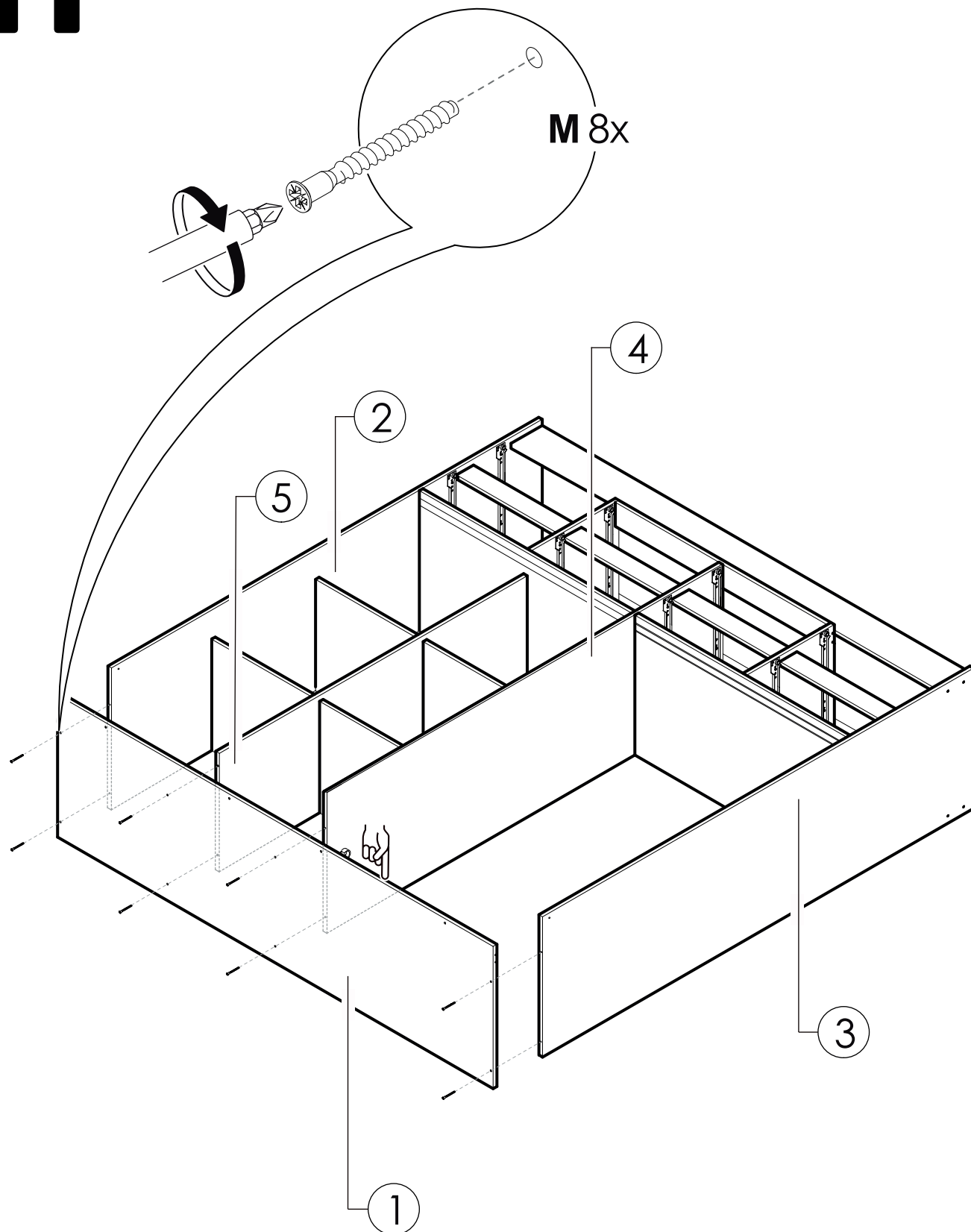

12

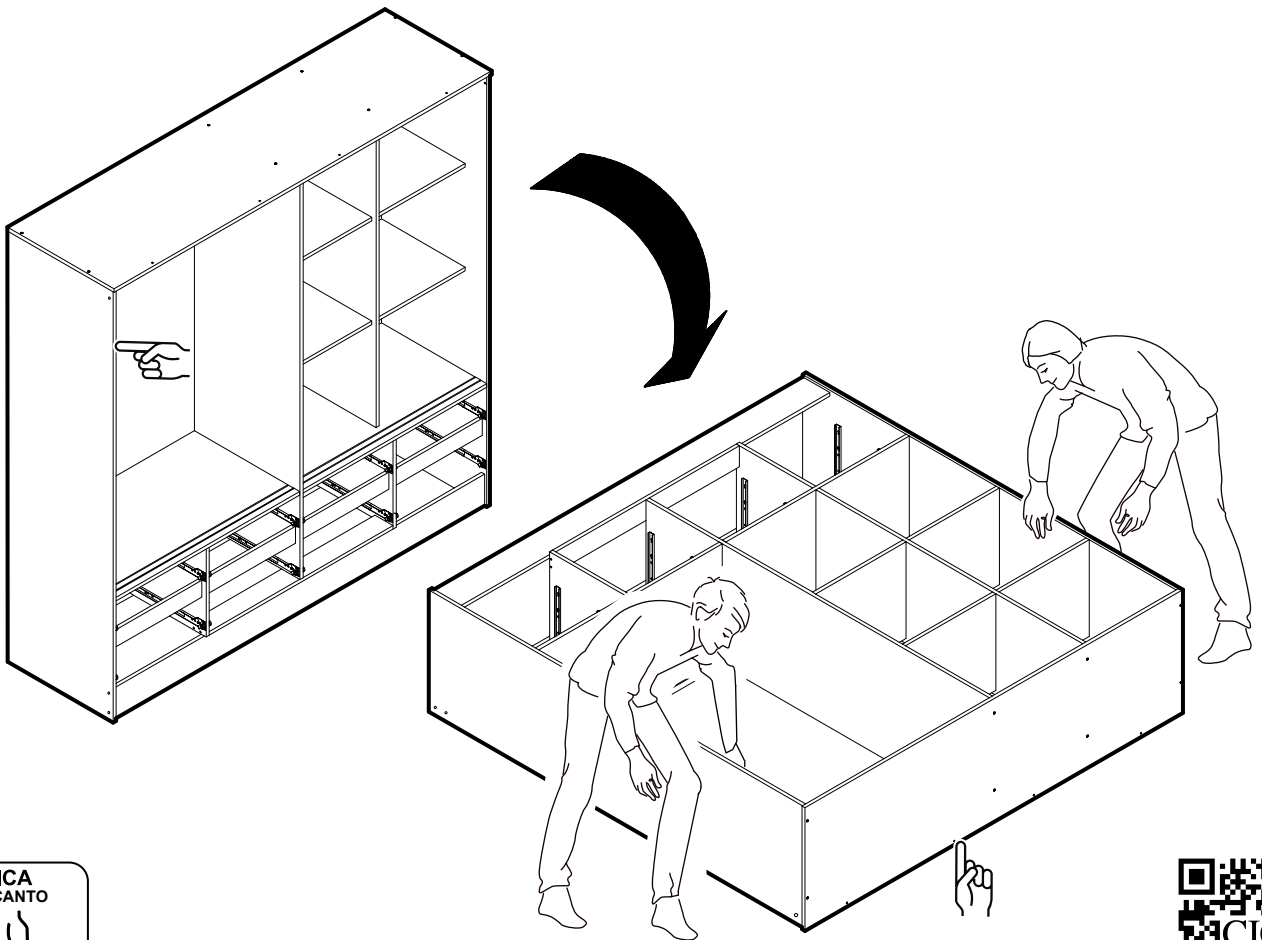
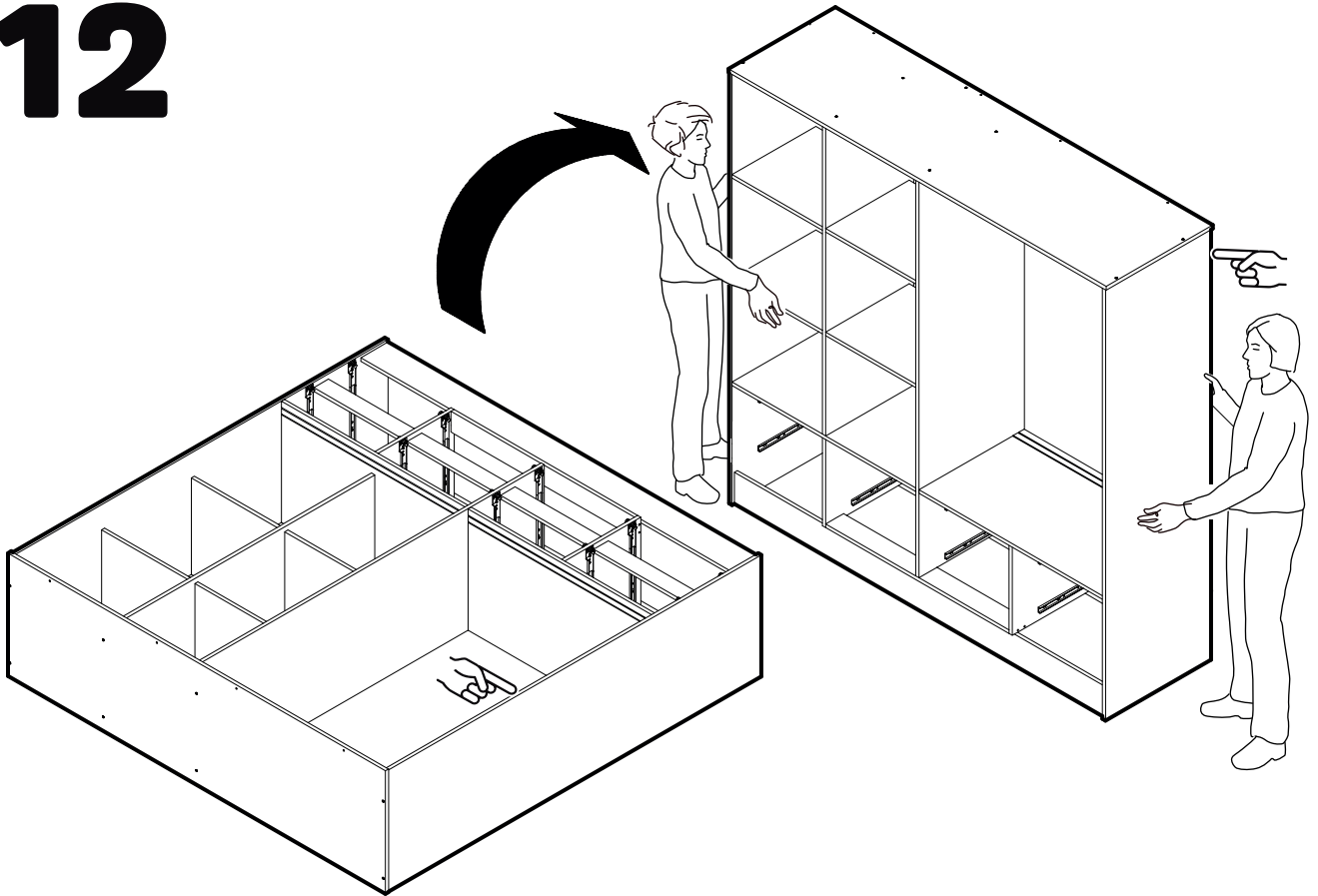

13



PRECAUCIÓN

LAS TRASERAS CENTRALES DEBEN COMPARTIR EL COSTADO CENTRAL, ASEGÚRESE DE ESTO ANTES DE CLAVAR.

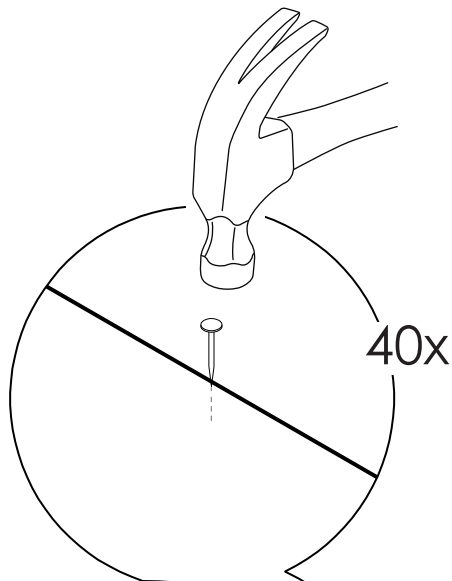

PRECAUCIÓN

DEL TOTAL DE CLAVOS (160 UNID.) OCUPAR 80 UNIDADES EN LA FIJACIÓN DE LAS TRASERAS.

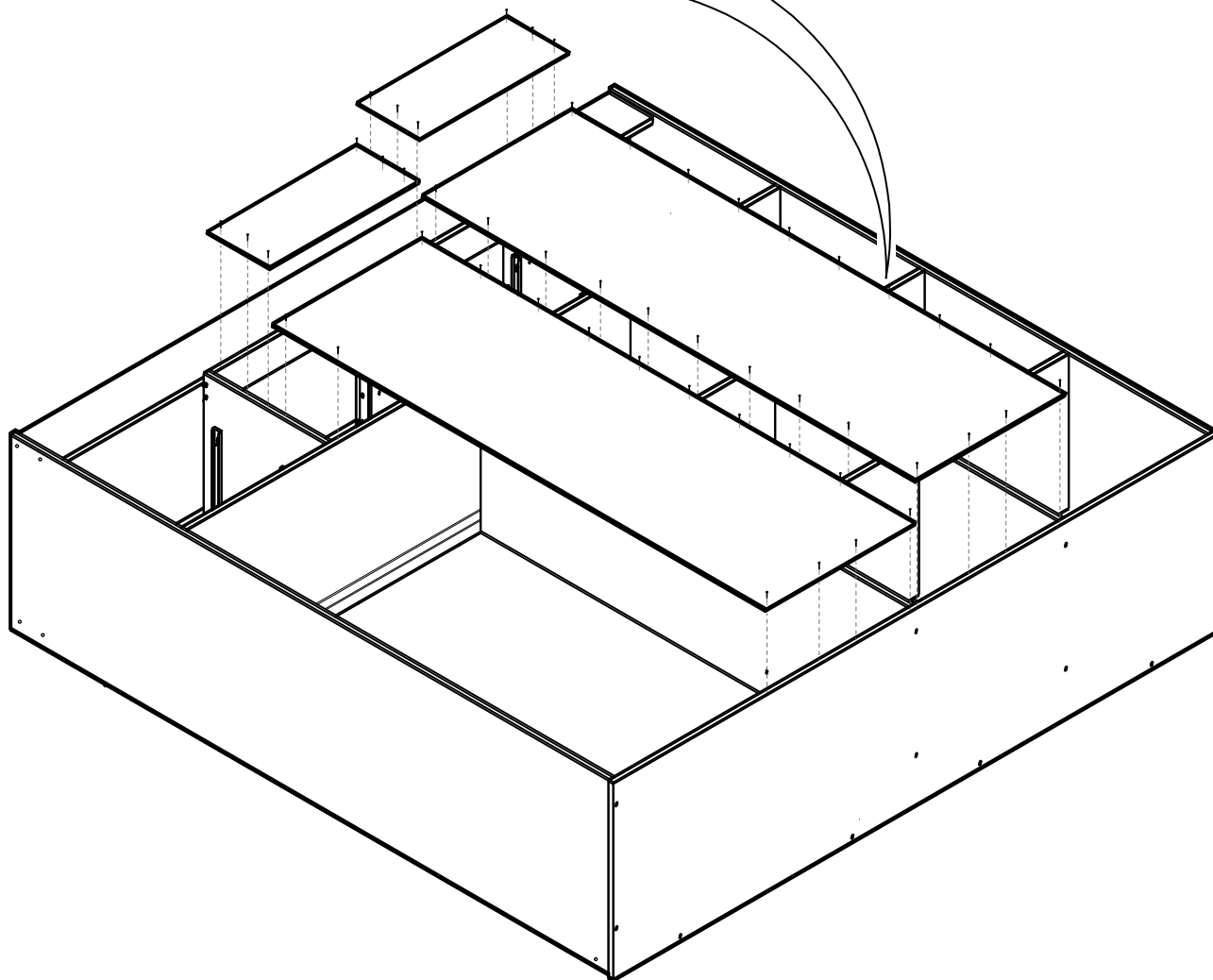

14

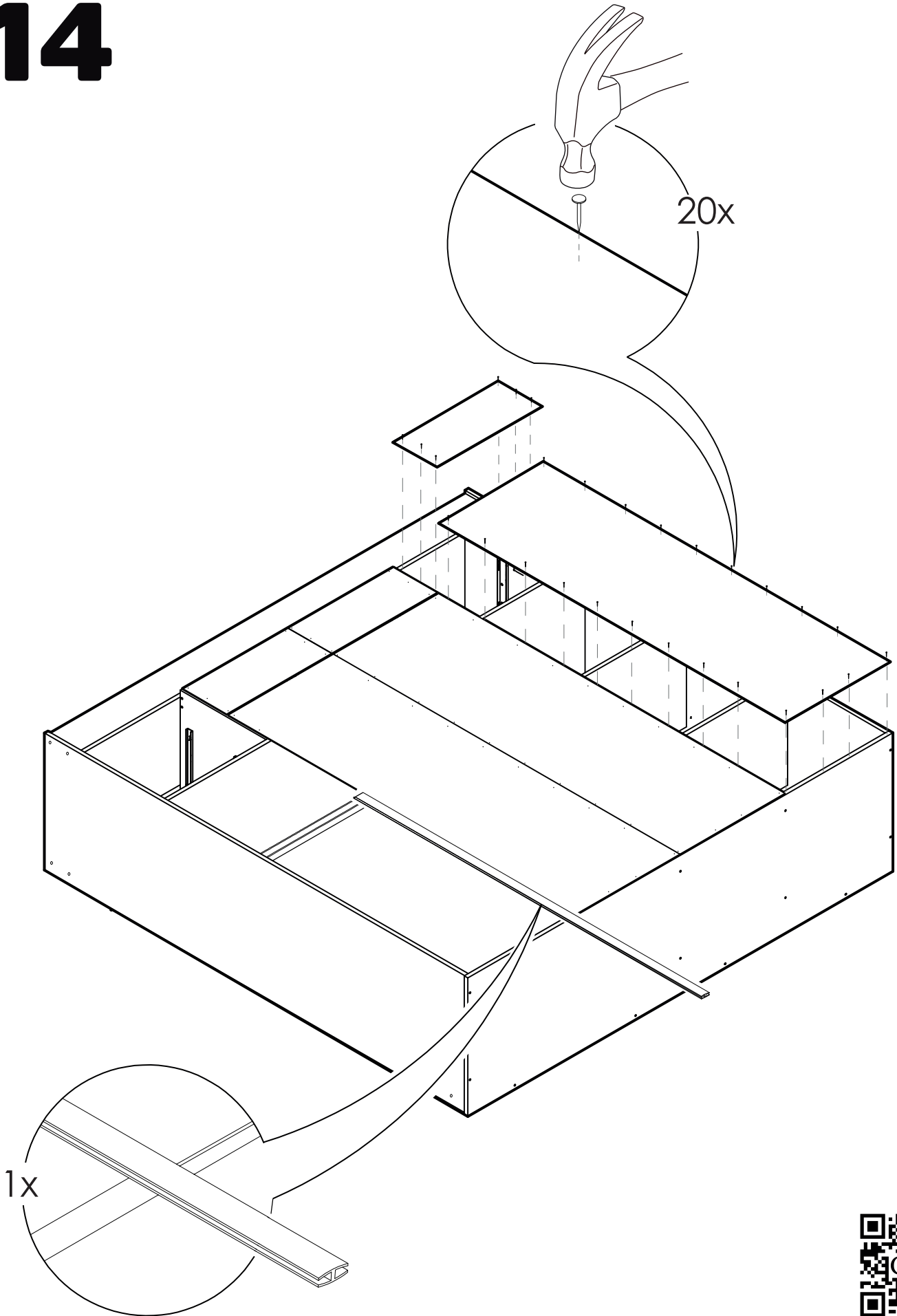

15

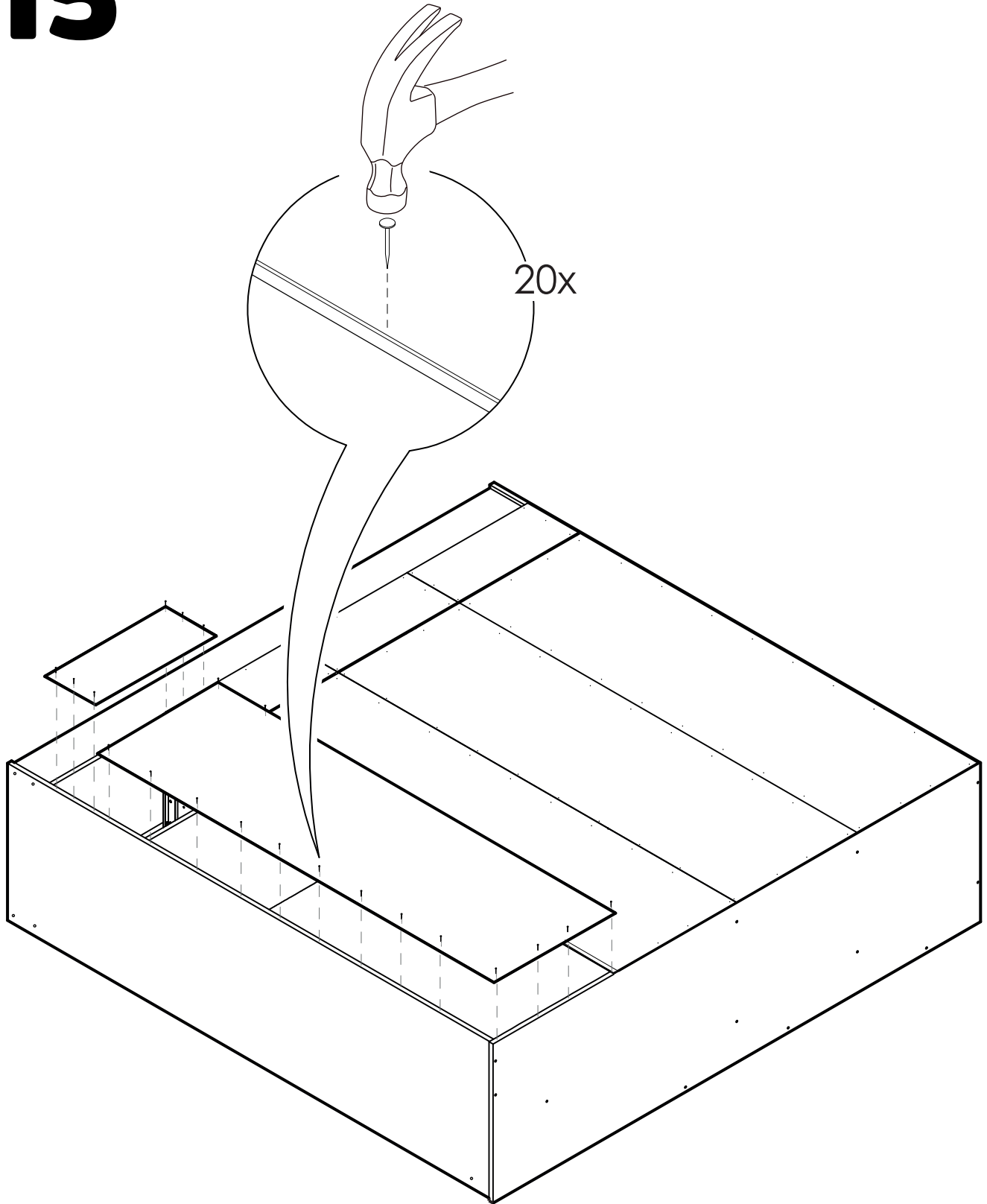

16

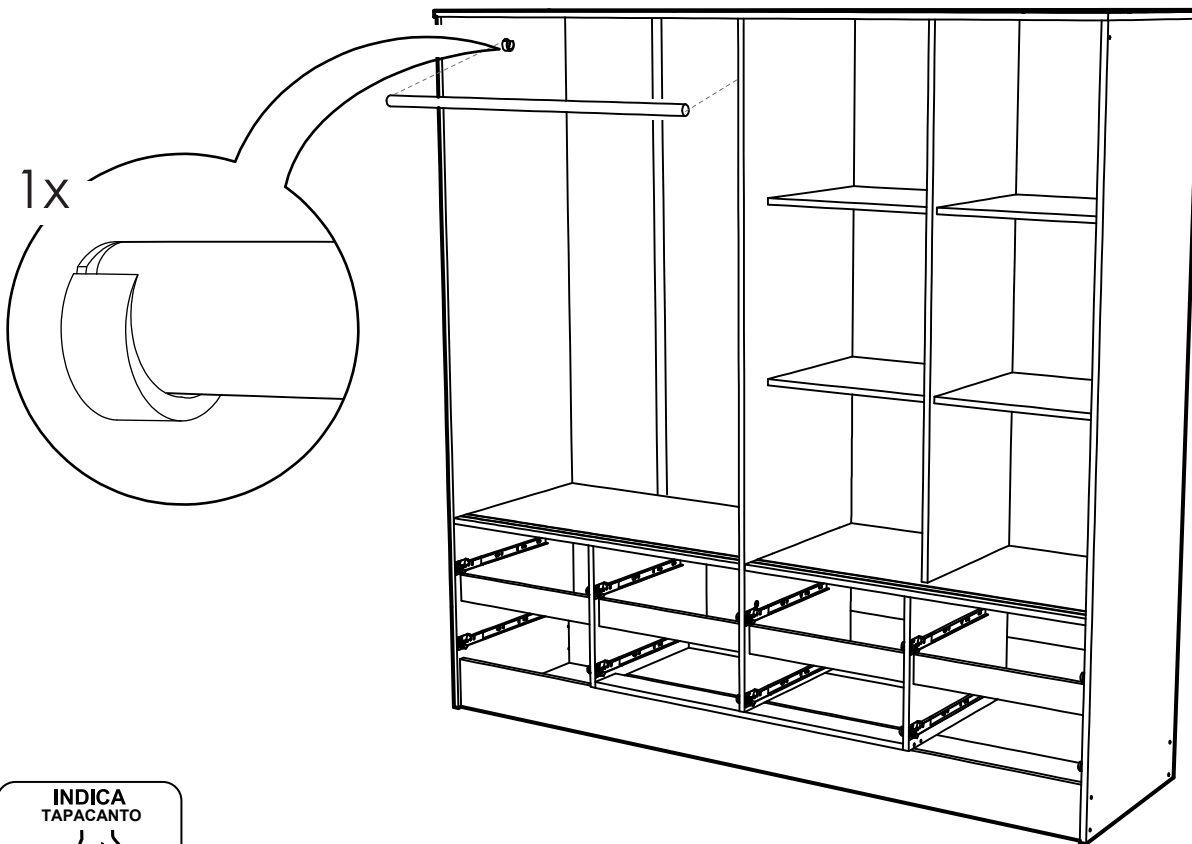
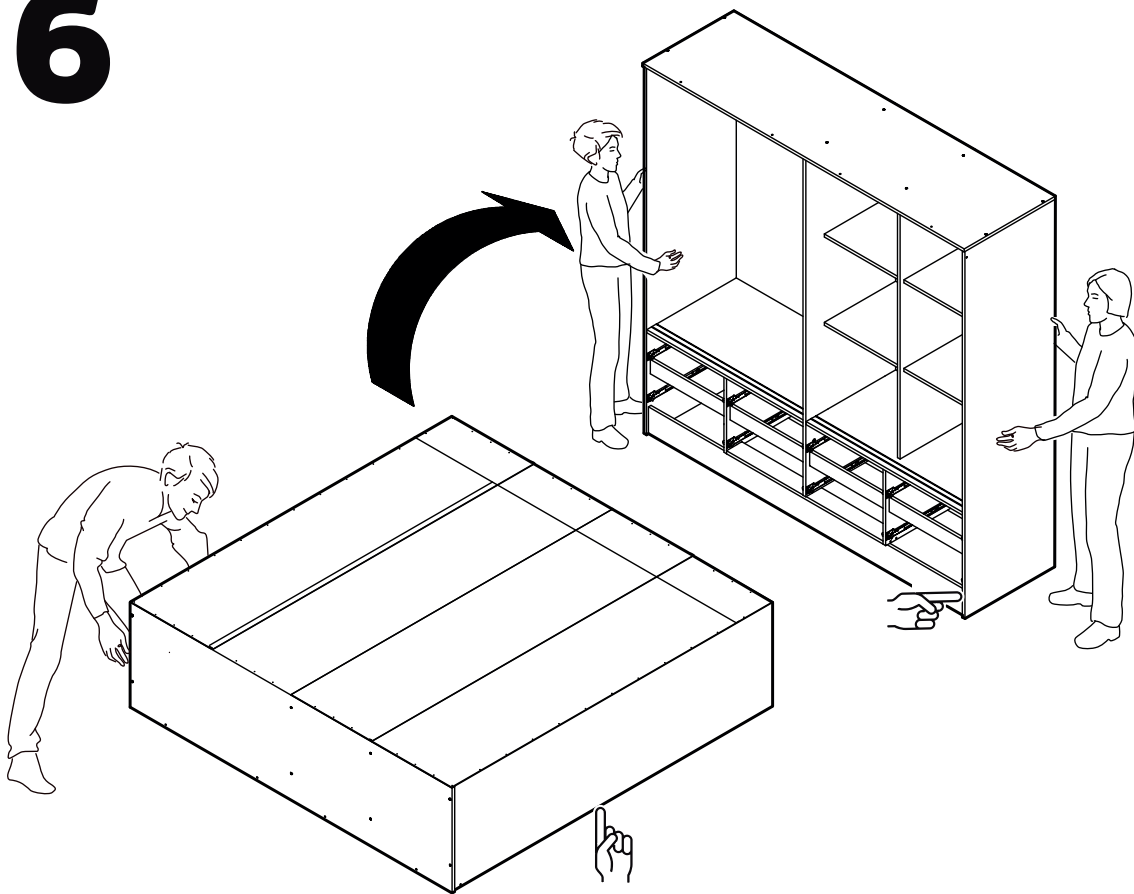

17

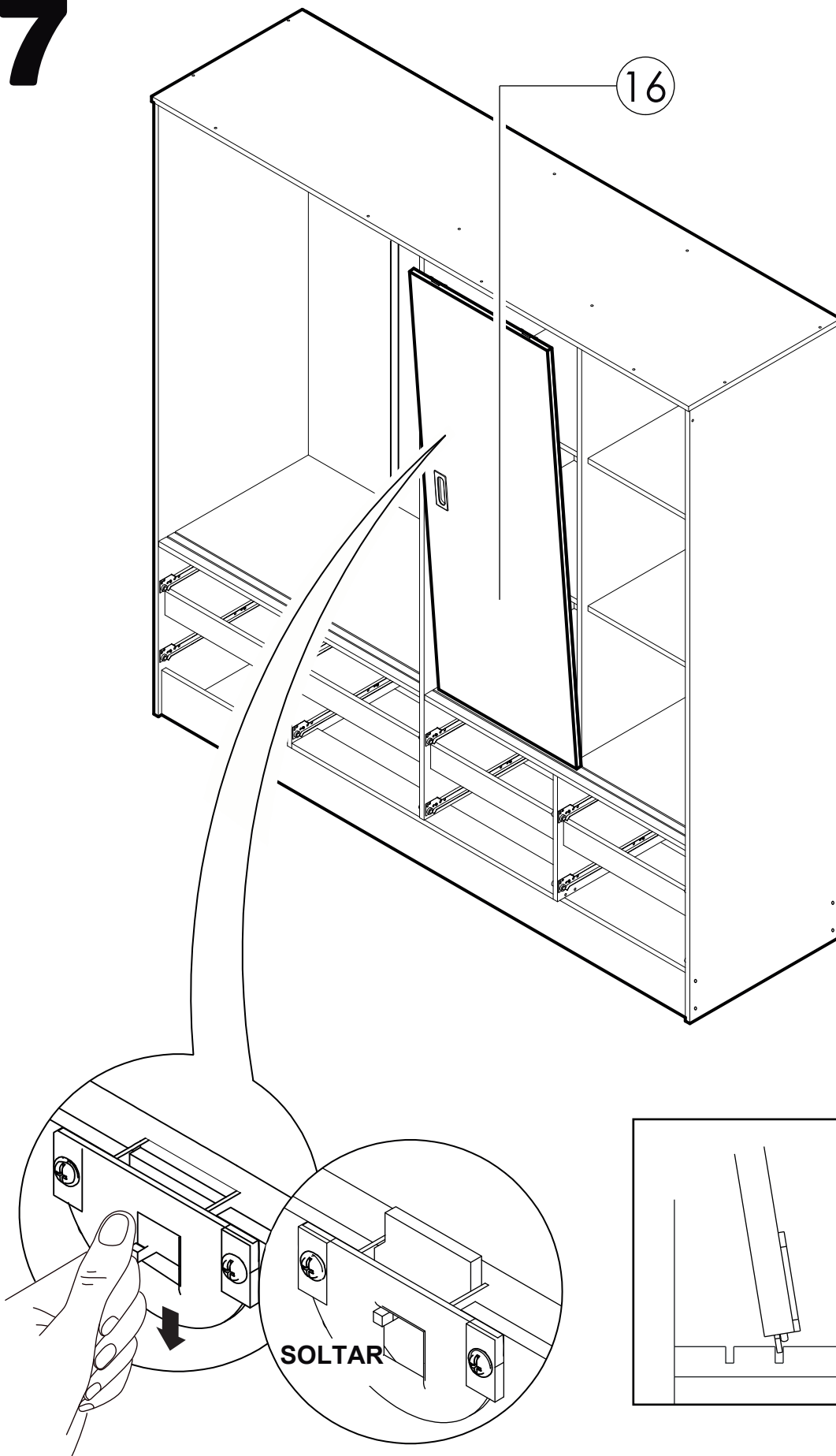

18

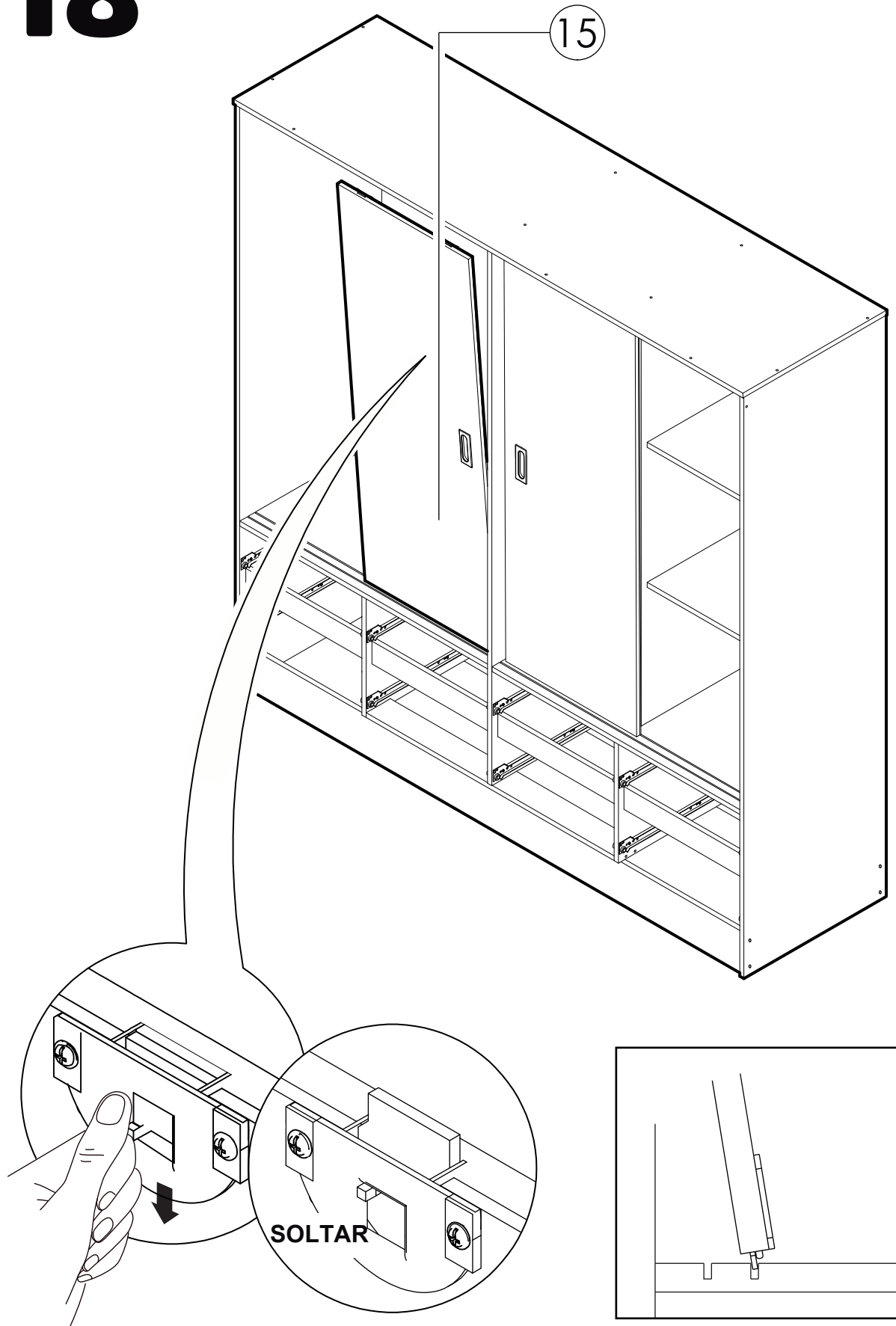

19

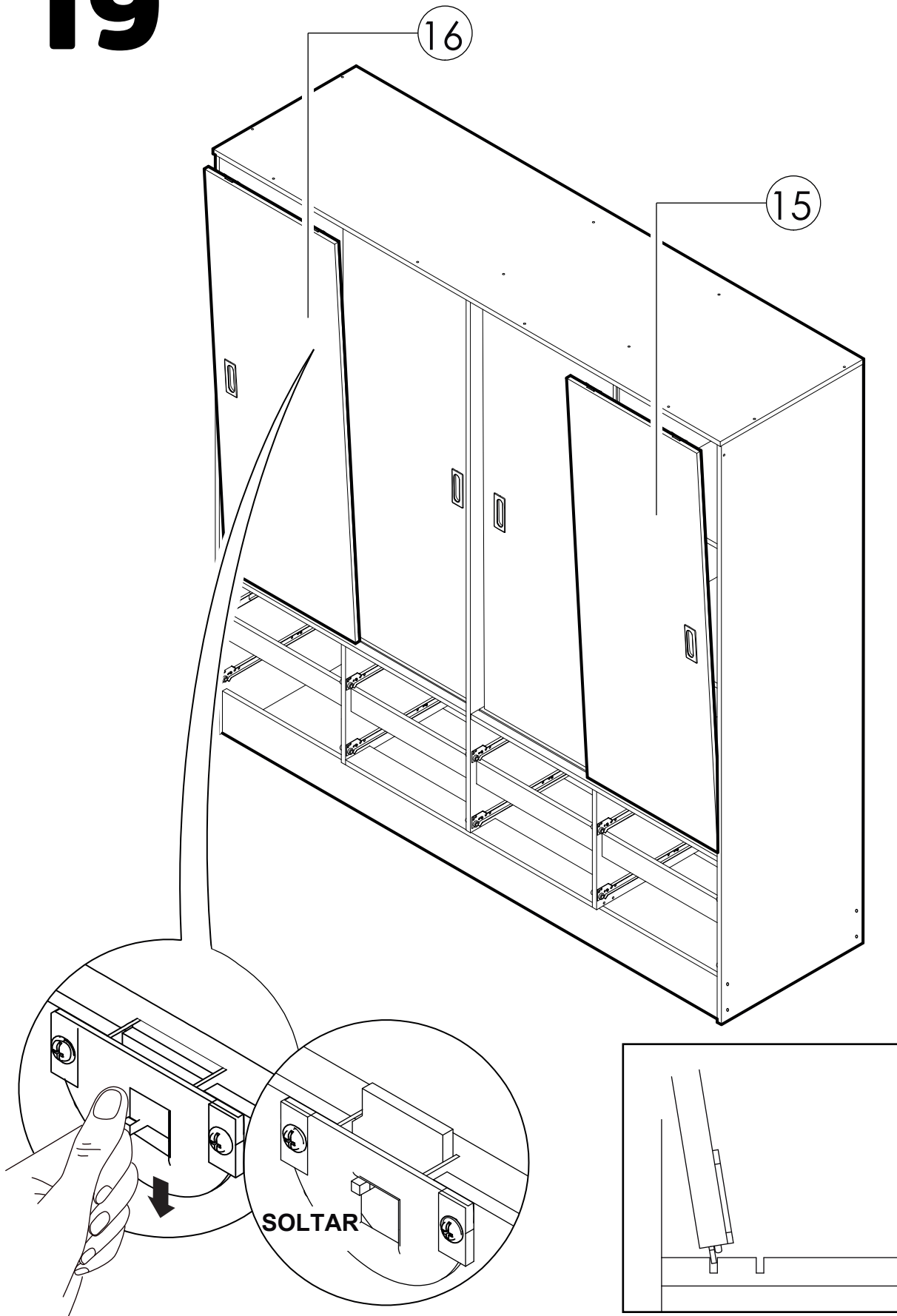

20

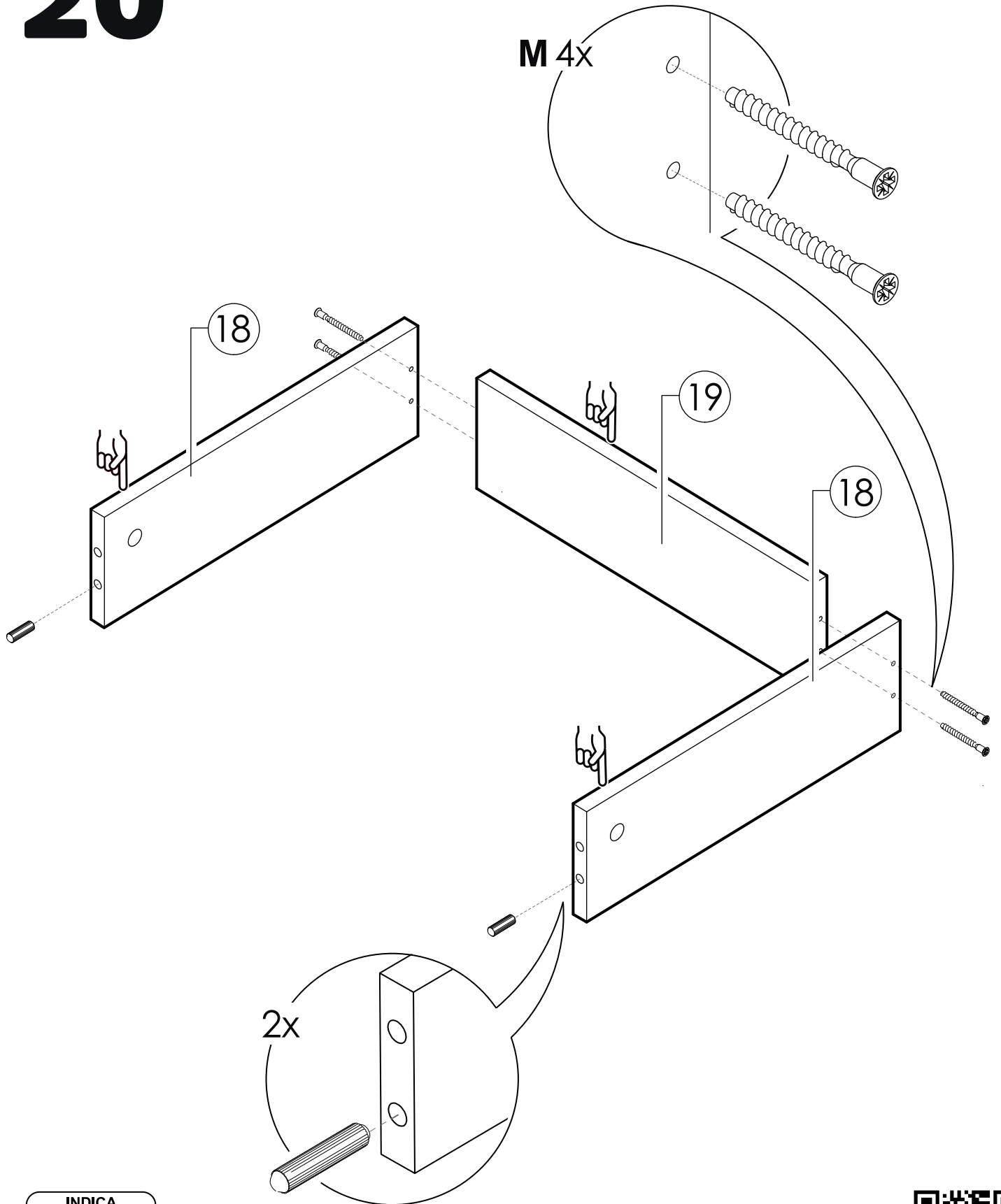

21

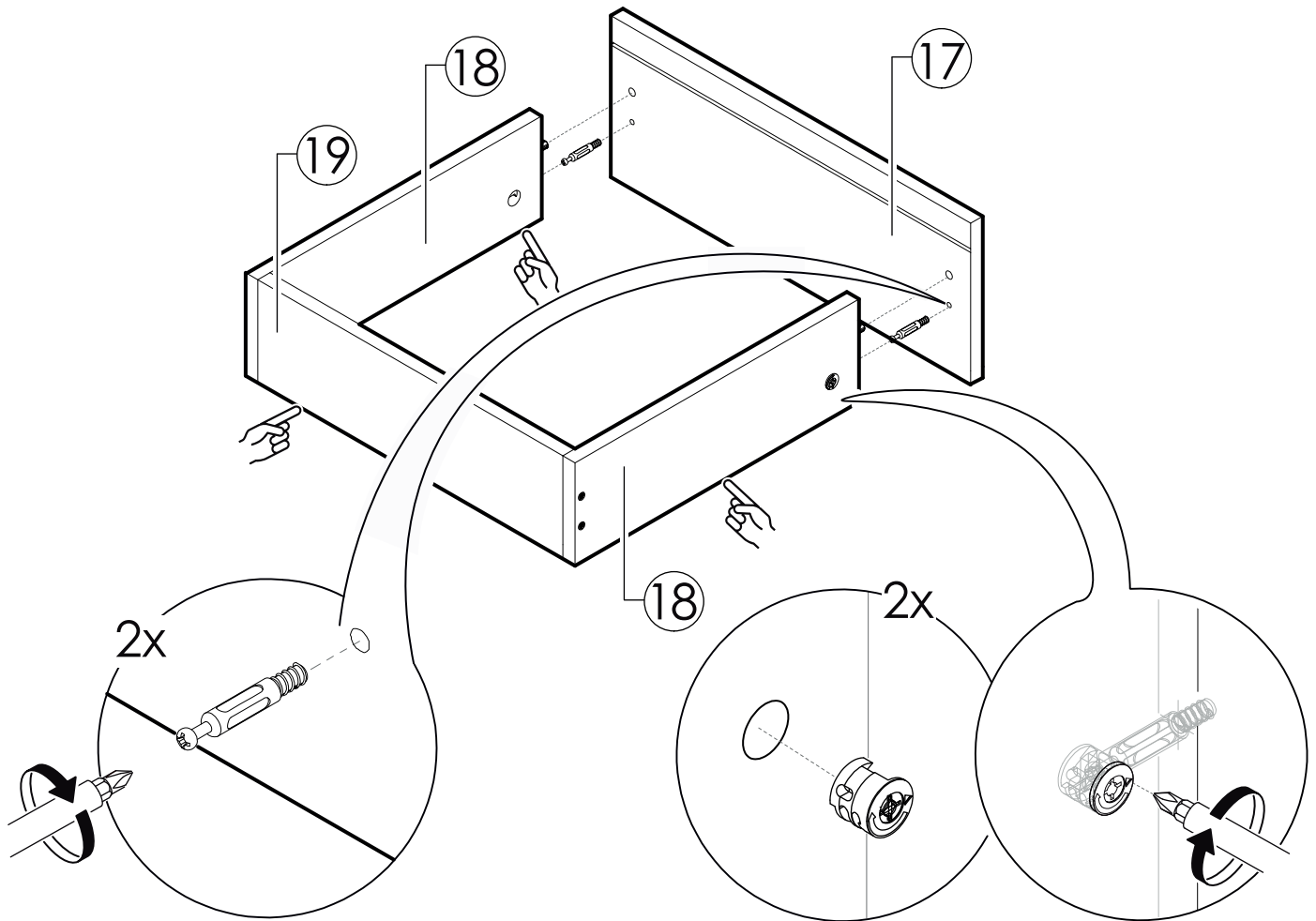

22

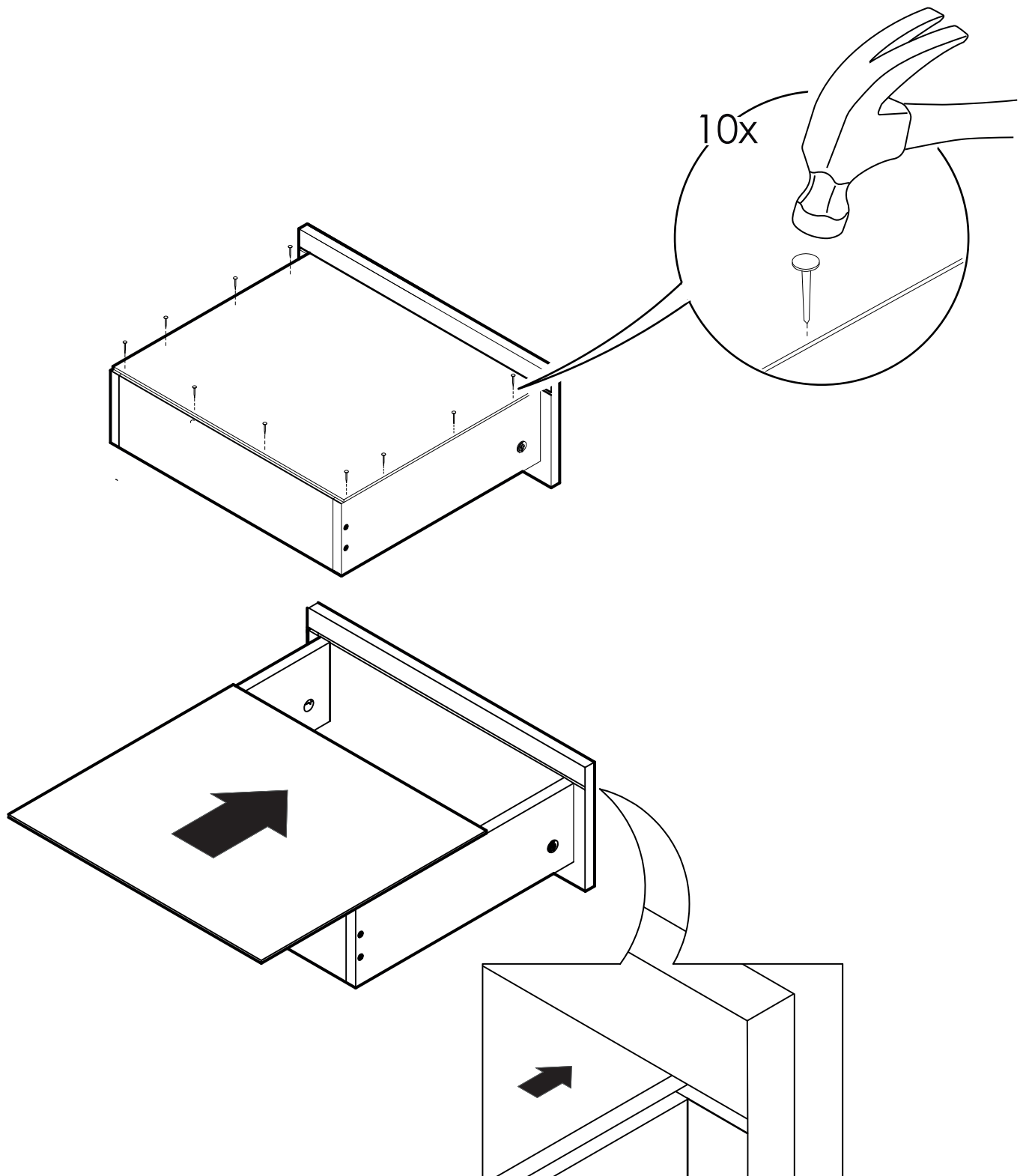

23



PRECAUCIÓN

CON MARTILLO Y CLAVO REALICE
ENCAMINADOS EN EL FONDO DE CAJÓN.

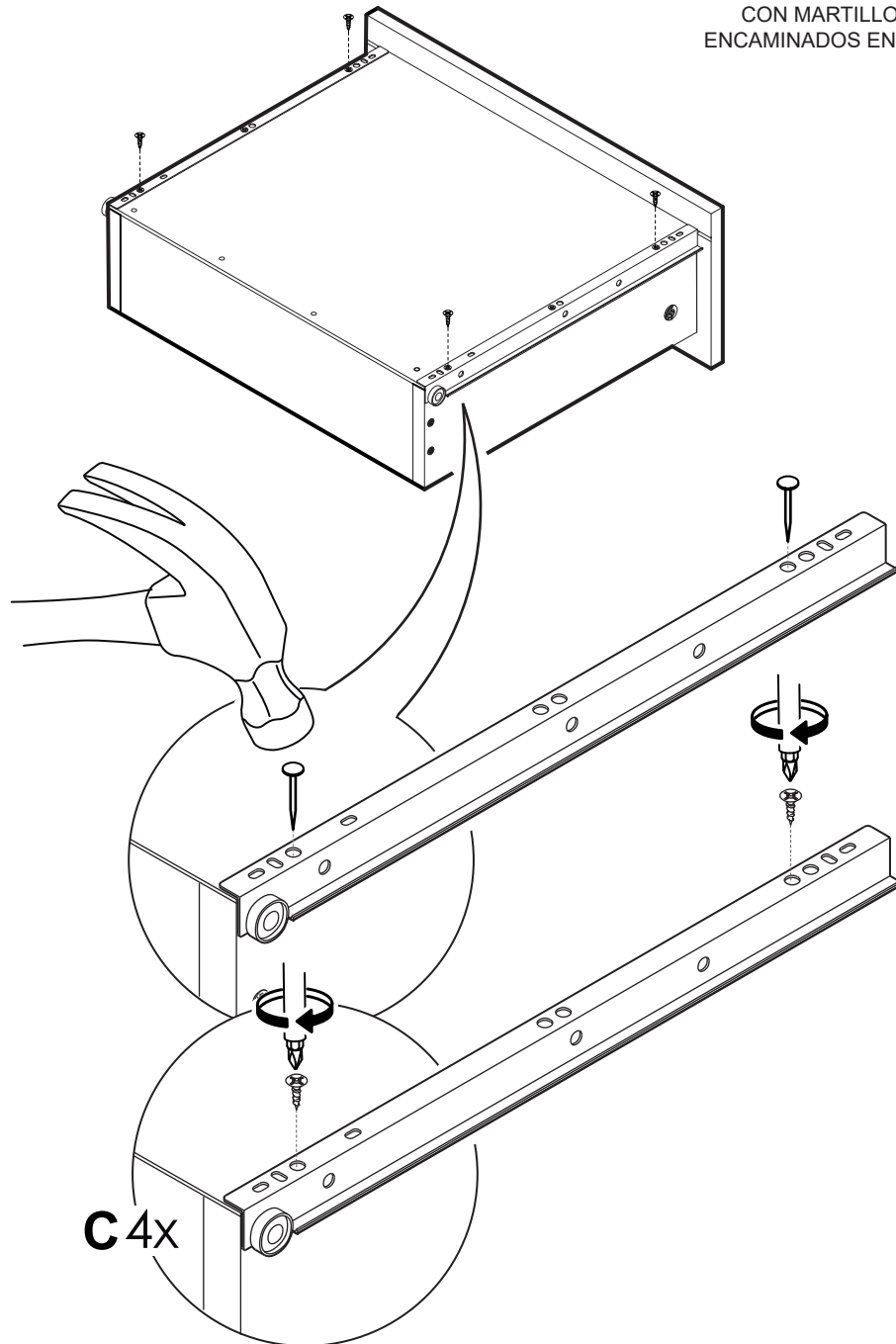

24

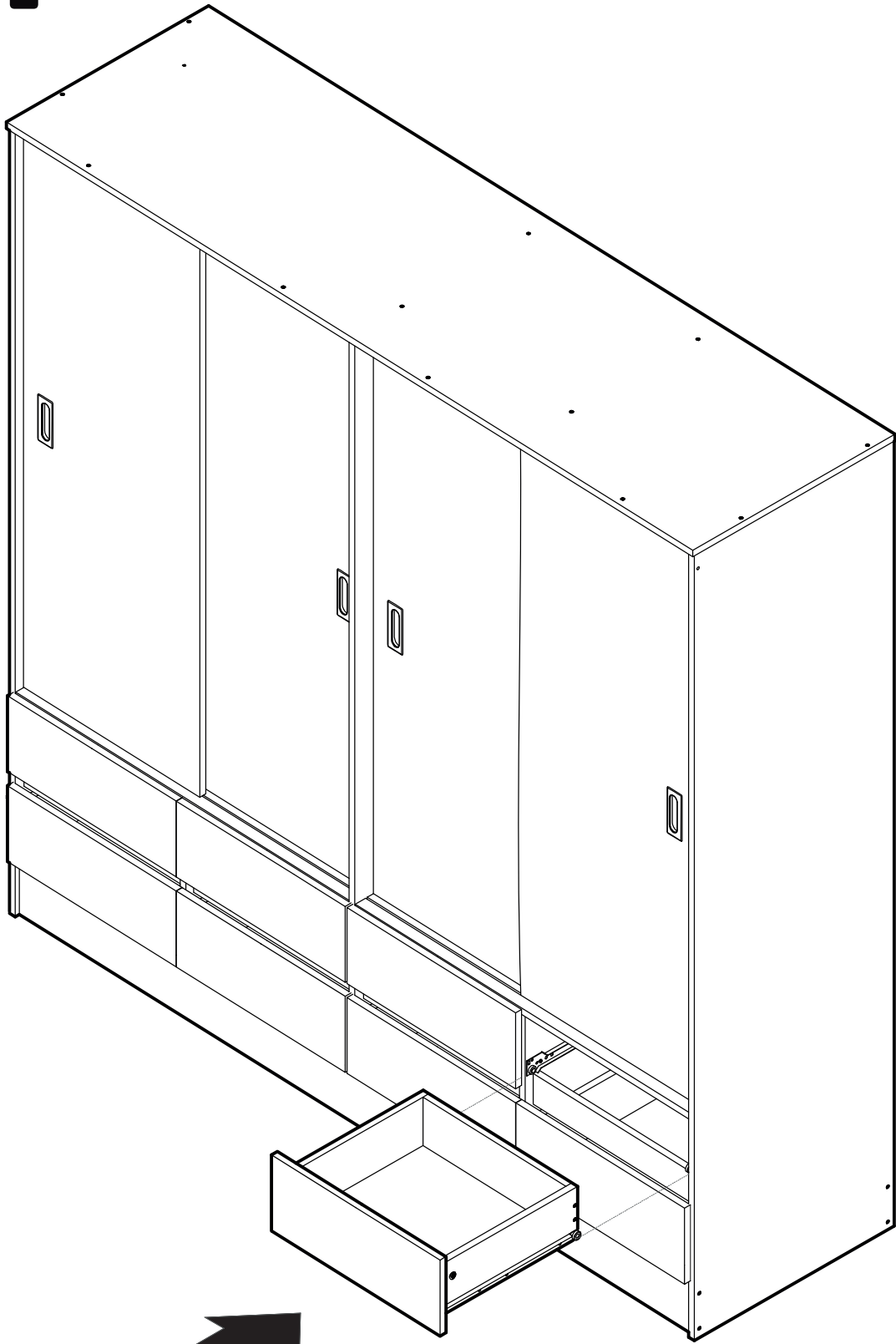

25

