

CLOSET

6 PUERTAS - 2 CAJONES



Encuentre su instructivo de armado:

- 1- Ingrese a www.cic.cl
- 2- Busque el nombre del mueble.
- 3- Haga click sobre el mueble seleccionado.
- 4- Diríjase a la opción "ARMALO TU MISMO"
- 5- Descargue el manual de armado.

o escanee el siguiente código QR.



HERRAMIENTAS

A USAR • NO INCLUIDAS

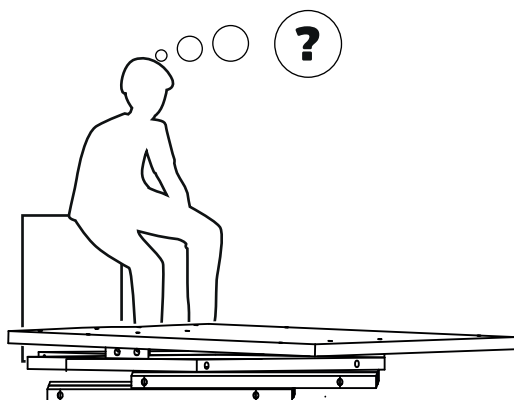
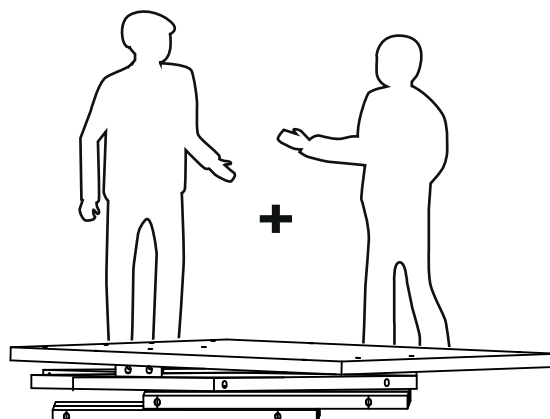
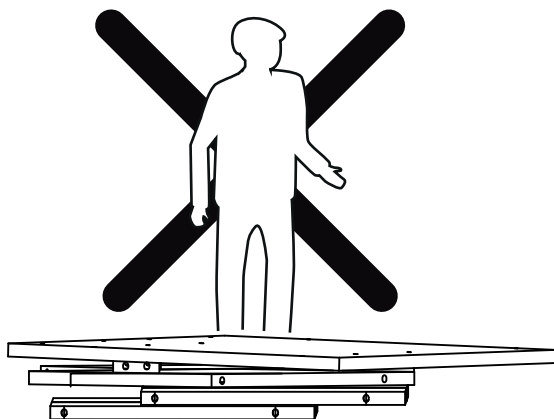
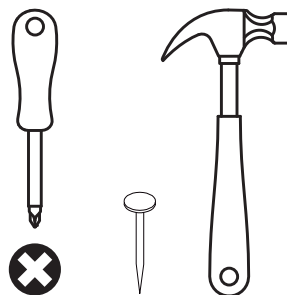

SERVICIO AL CLIENTE
800 74 00 00

INDICA TAPANCANTO

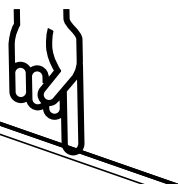

- 1 - Revise que todos los herrajes contenidos en la(s) bolsa(s) coincidan con el listado de herrajes indicado en las siguientes páginas.
- 2- No elimine ningún número de las piezas. Una vez armado el mueble puede desprenderlos y/o borrarlos (los números impresos puede borrarlos con alcohol, alcohol gel o desinfectante de ambientes)
- 3 -Revise que todos los herrajes de la(s) bolsa(s) coincidan con el listado que aparece en este instructivo (tipo de herraje y cantidad)
- 4- No retire el número que va pegado en el exterior de la caja. Este número se denomina código de trazabilidad (ej.: 0871265) y tiene por objetivo hacer el seguimiento al mueble, en caso de que se presenten problemas en el armado.

PIEZAS Y COMPONENTES

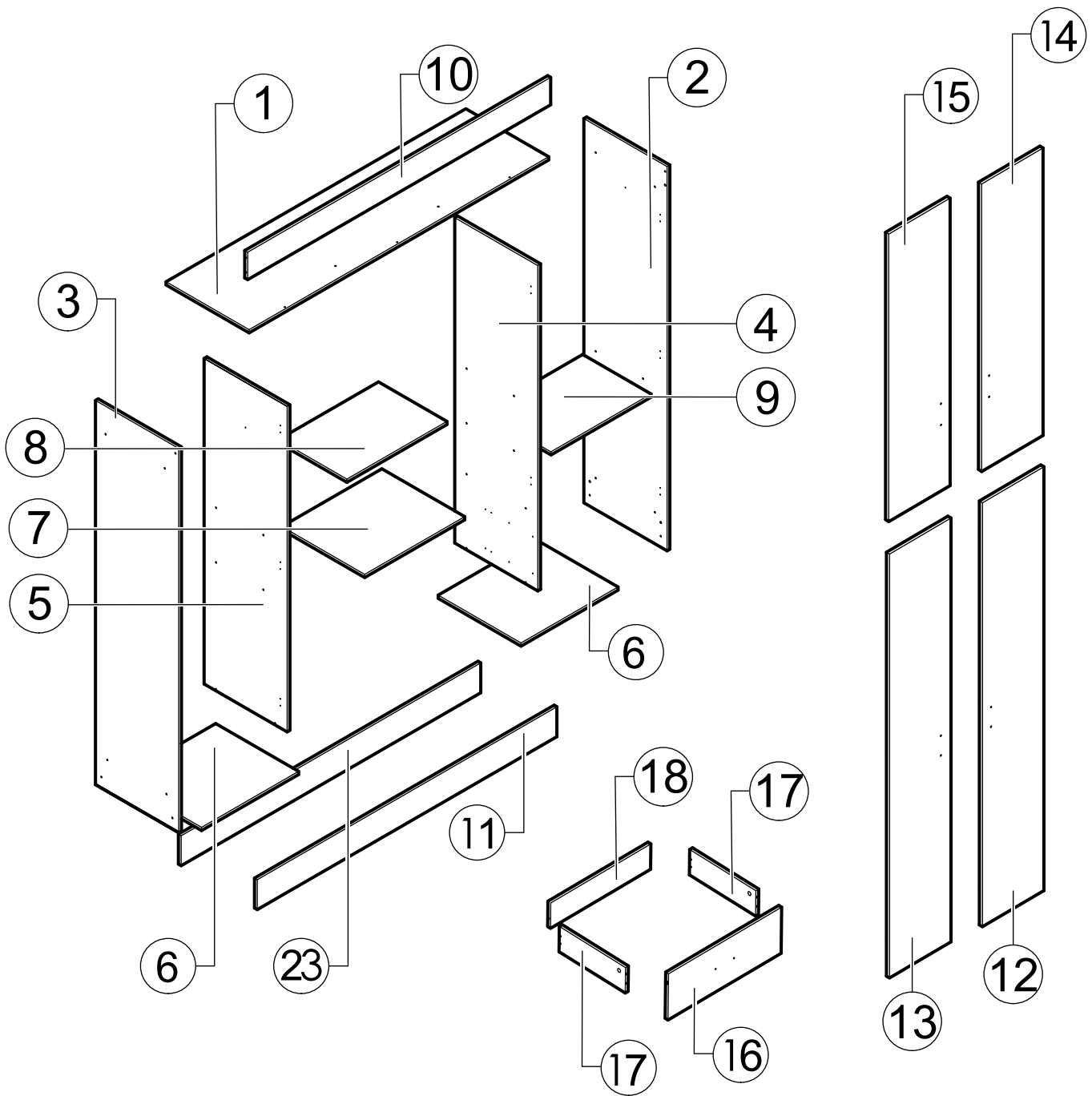

1	CUBIERTA	x1
2	COSTADO DERECHO	x1
3	COSTADO IZQUIERDO	x1
4	COSTADO INTERIOR DERECHO	x1
5	COSTADO INTERIOR IZQUIERDO	x1
6	FONDO	x2
7	REPISA FIJA CENTRAL INFERIOR	x1
8	REPISA FIJA CENTRAL SUPERIOR	x1
9	REPISA FIJA LATERAL	x1
10	BARRA SUPERIOR	x1

11	ZOCALO DELANTERO	x1
12	PUERTA LARGA DERECHA	x2
13	PUERTA LARGA IZQUIERDA	x2
14	PUERTA CORTA DERECHA	x1
15	PUERTA CORTA IZQUIERDA	x1
16	FRENTE CAJÓN	x2
17	COSTADO CAJÓN	x4
18	TRASERA CAJÓN	x2
23	ZÓCALO TRASERO	x1

HERRAJES



x2



C x20



x4

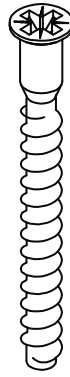

M x42



T x16

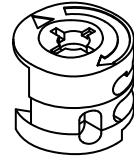

x4

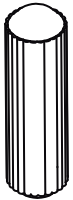

x10



x100



F x7



S x12

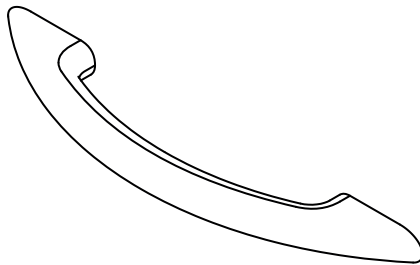

x8

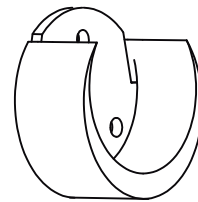

x4

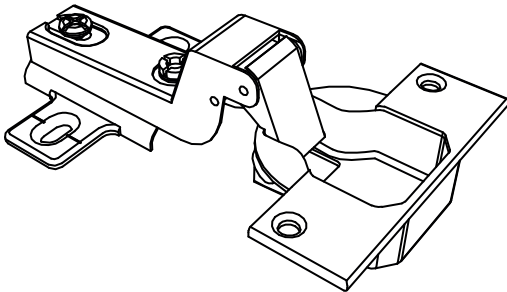

x16

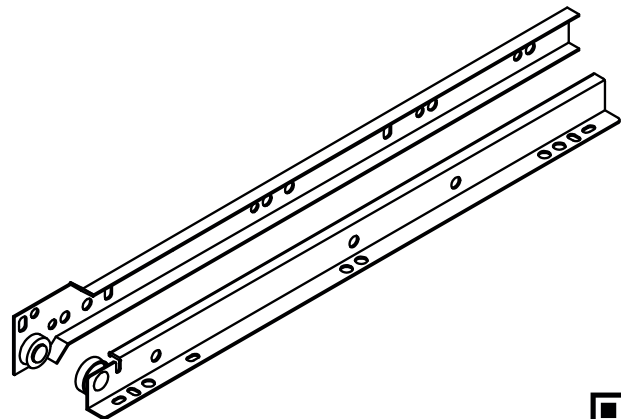

x2



PREPARACIÓN DE PIEZAS

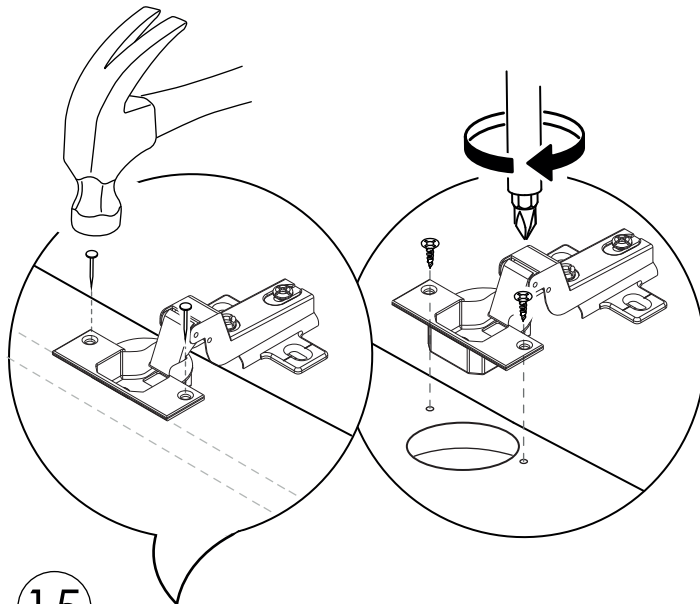

PRECAUCIÓN

LAS PERFORACIONES PARA TORNILLOS DEBE HACERLAS USTED CON MARTILLO Y CLAVO. SE RECOMIENDA COLOCAR UNA GUÍA RECTA A LO LARGO DE LAS 2 BISAGRAS PARA MANTENERLAS EN UNA POSICIÓN CORRECTA.

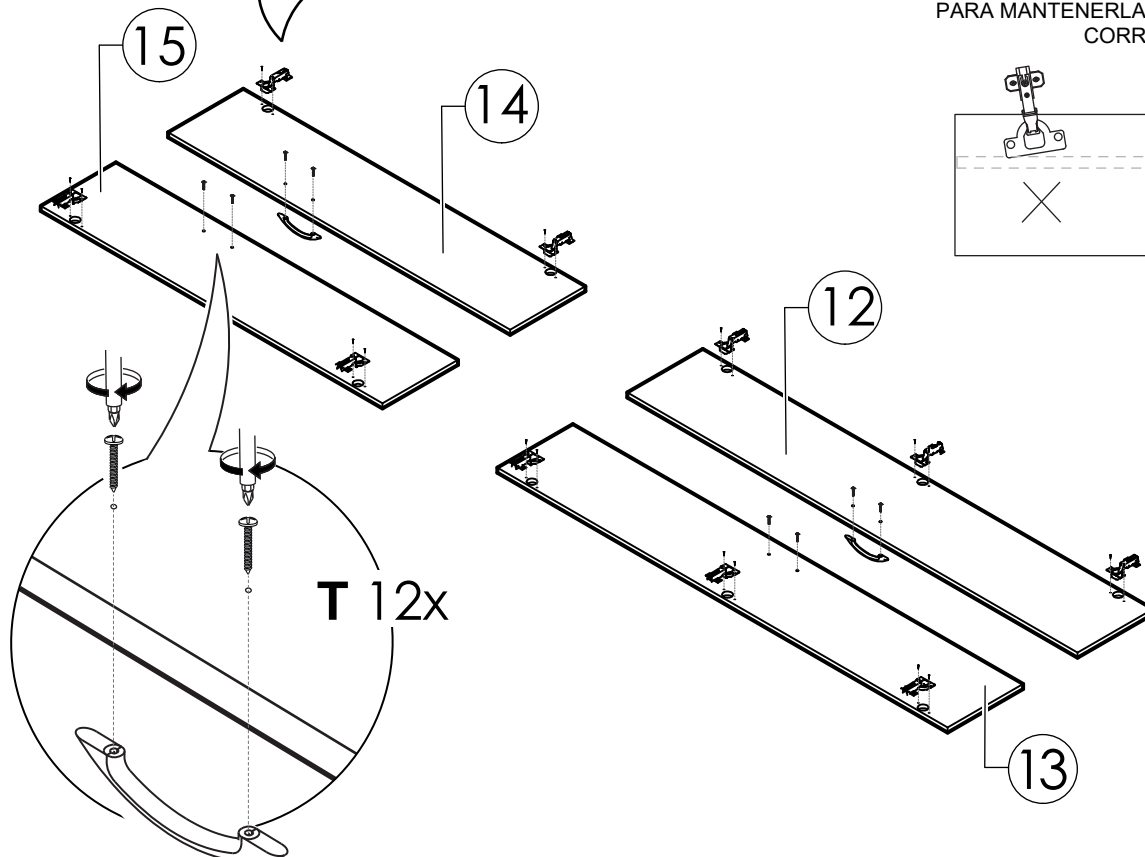
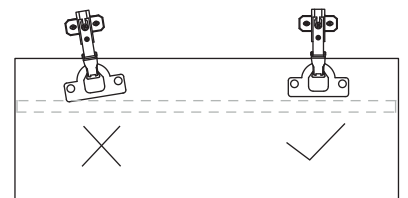

PREPARACIÓN DE PIEZAS

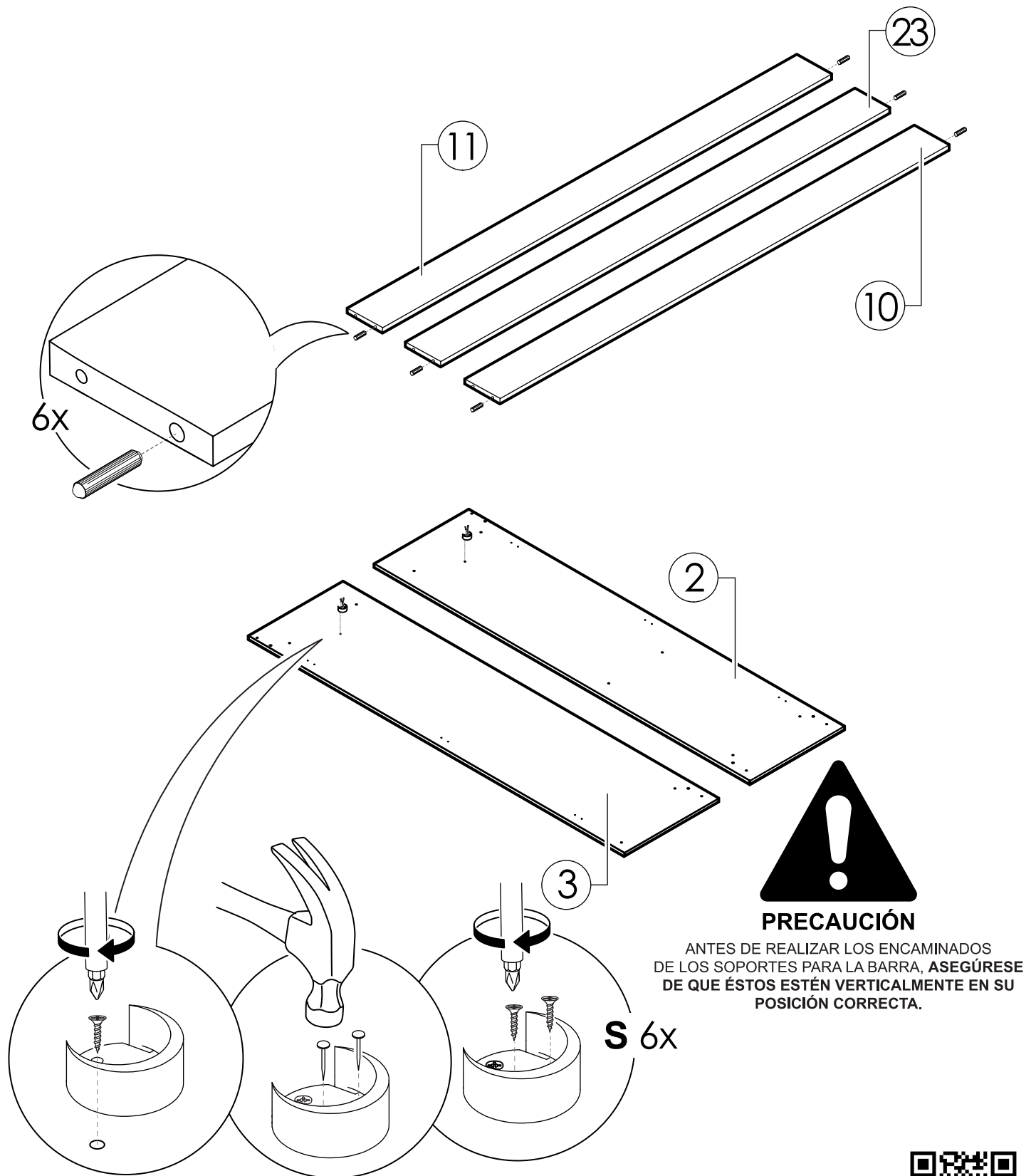

PREPARACIÓN DE PIEZAS



PRECAUCIÓN

ANTES DE REALIZAR LOS ENCAMINADOS DE LOS SOPORTES PARA LA BARRA, ASEGÚRESE DE QUE ÉSTOS ESTÉN VERTICALMENTE EN SU POSICIÓN CORRECTA.

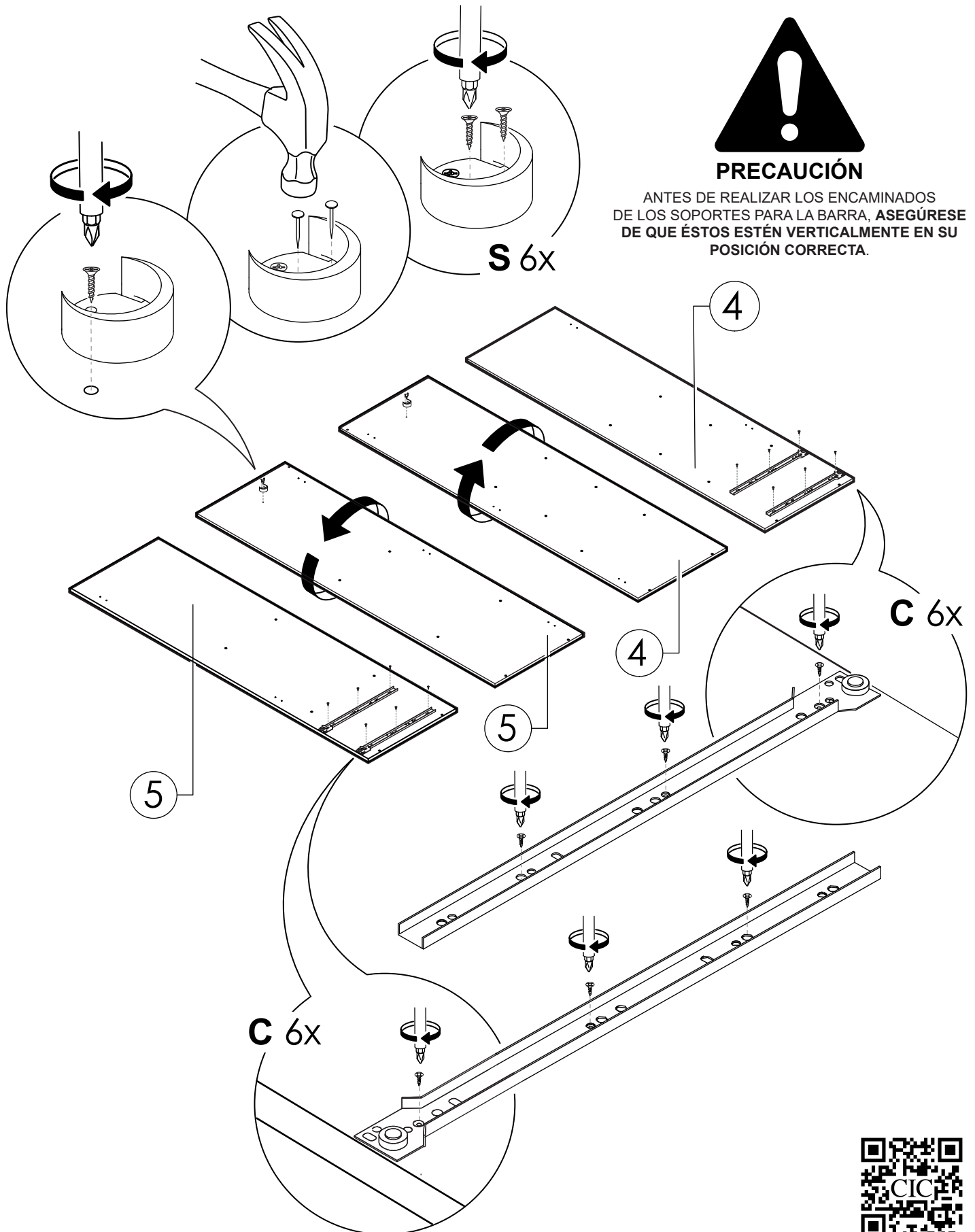

1

SECUENCIA DE ARMADO

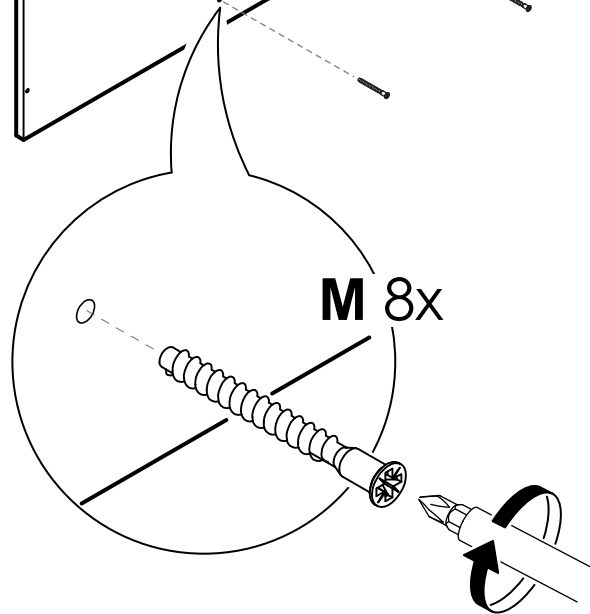
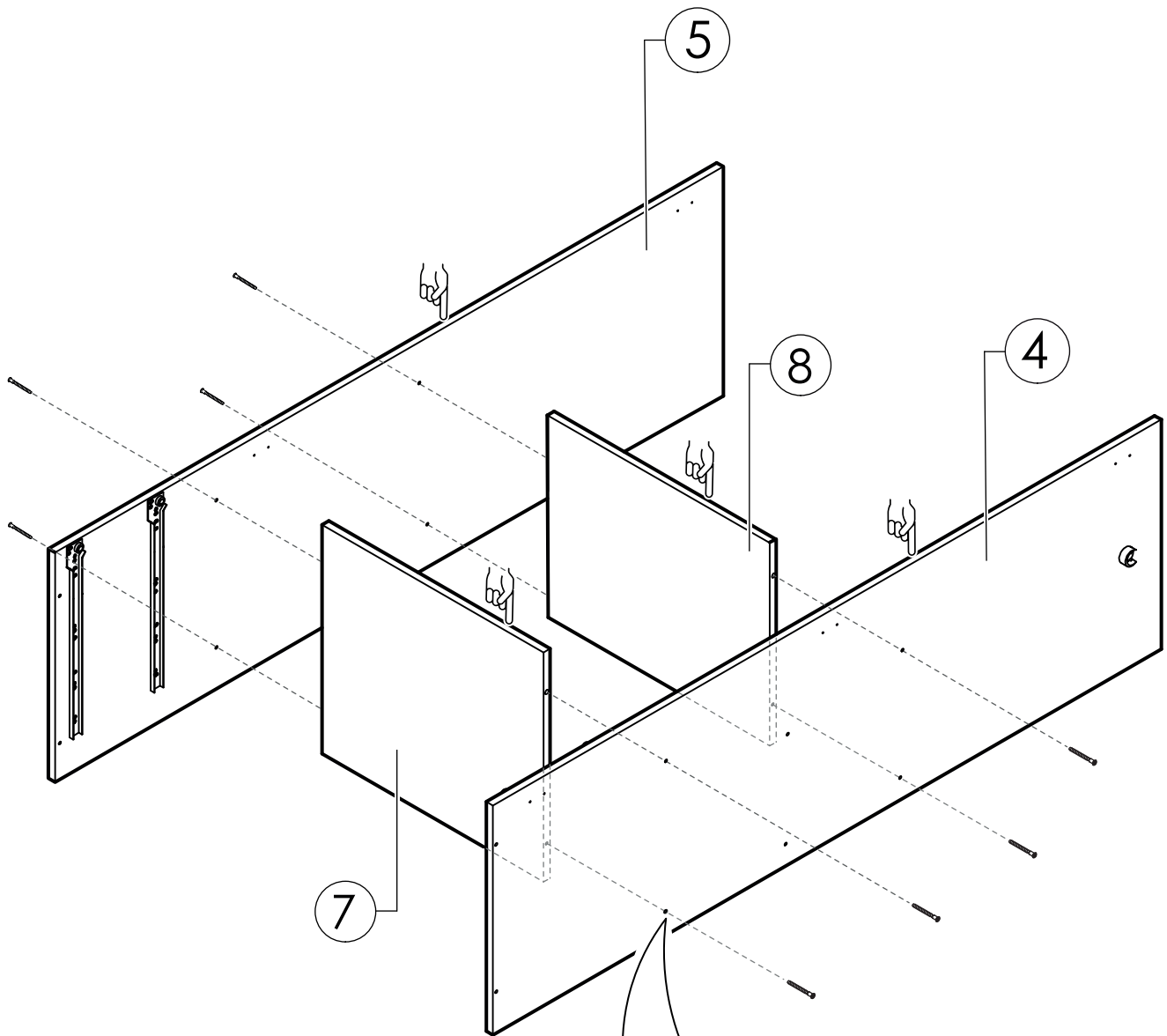

2

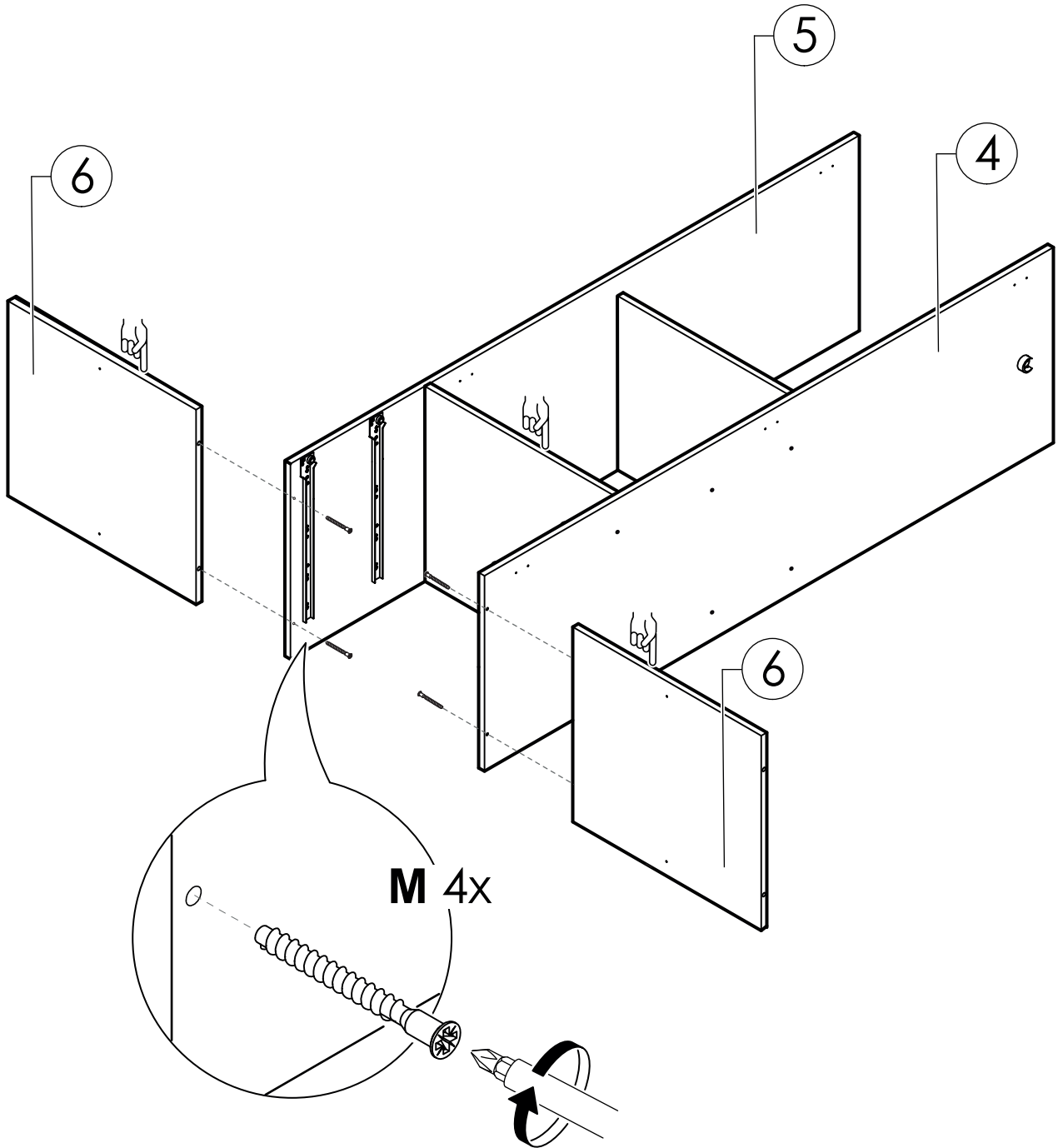

3

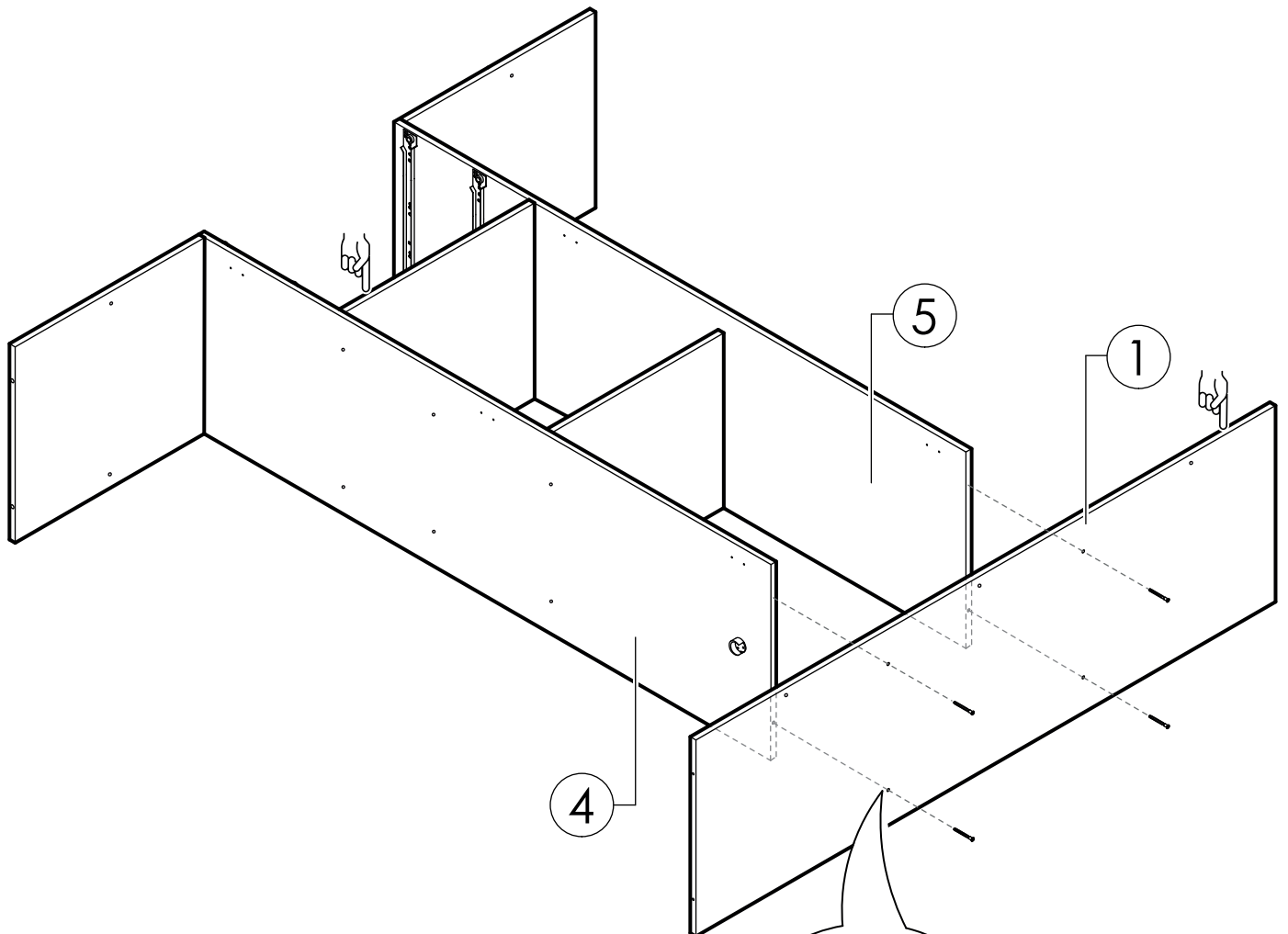

PRECAUCIÓN

ESTA VISTA MUESTRA
EL LADO CONTRARIO DE LA ANTERIOR
PAGINA PARA UNA MEJOR
VISUALIZACIÓN DEL ARMADO.

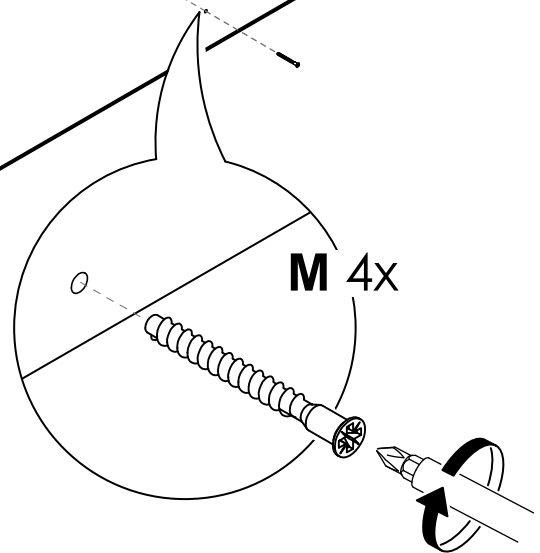

4

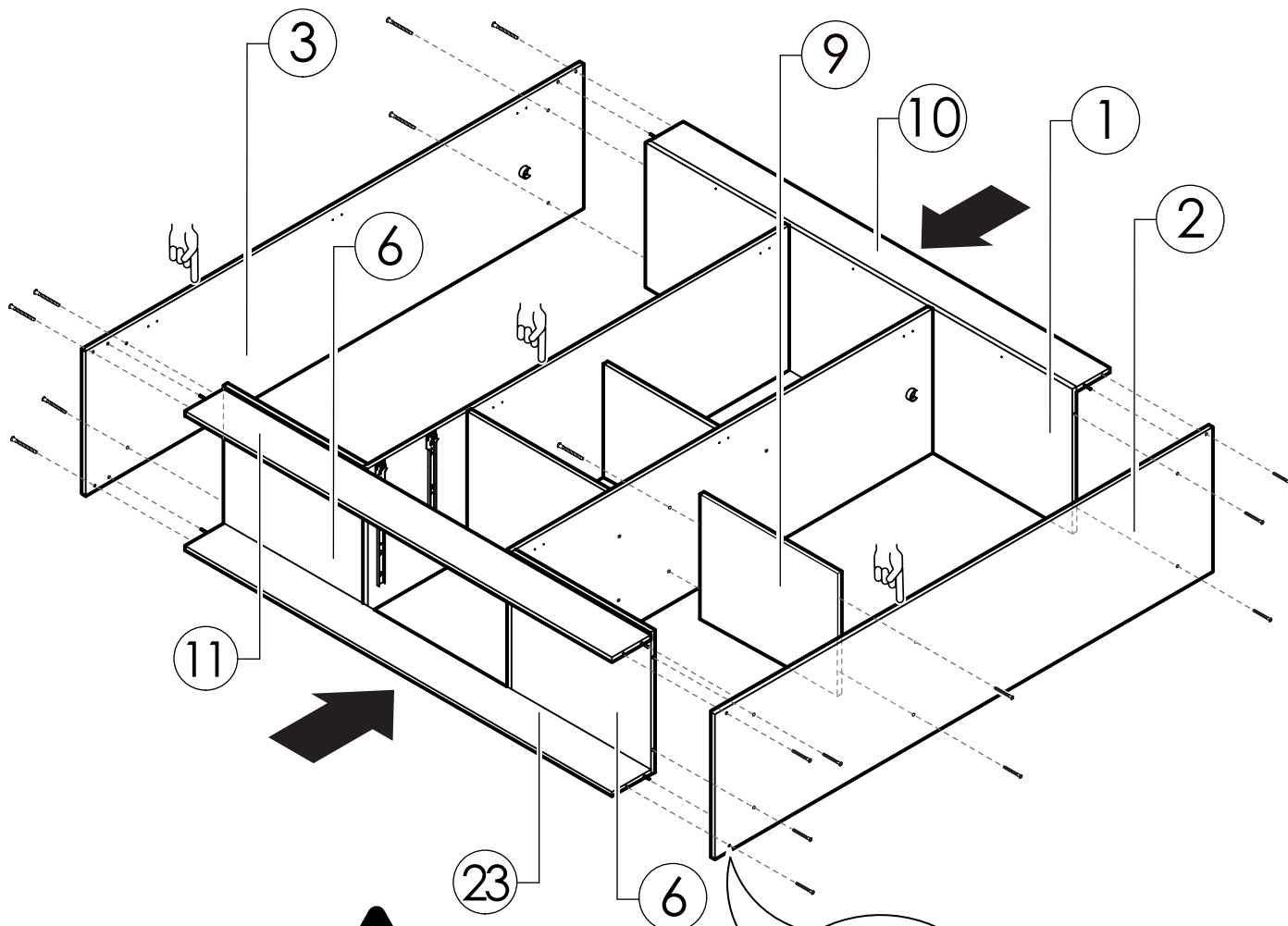

PRECAUCIÓN

AYÚDESE DE OTRA PERSONA PARA SUJETAR
LA BARRA SUPERIOR Y LOS ZÓCALOS.



5

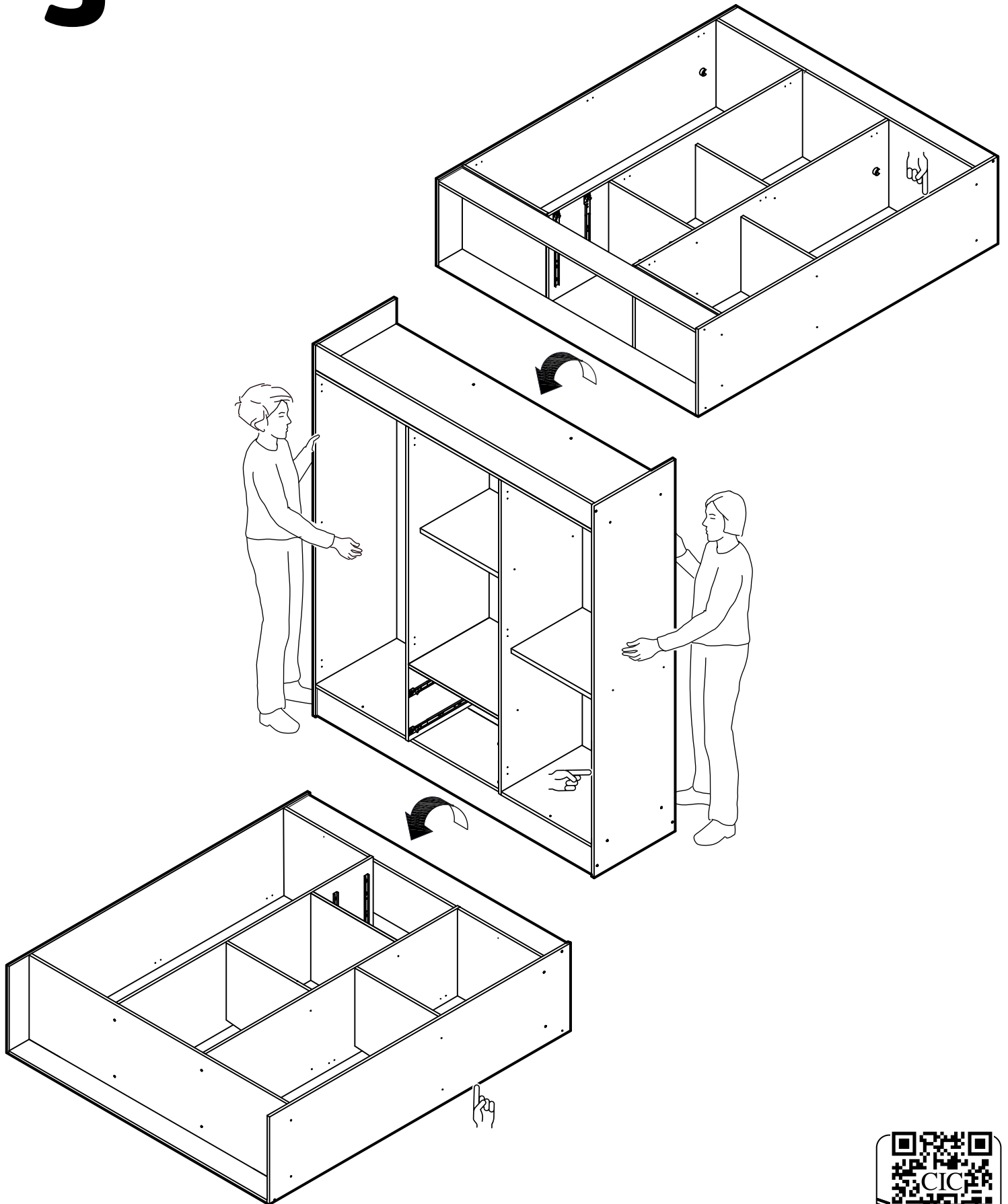

6



PRECAUCIÓN

COMIENZE FIJANDO LAS TRASERAS CENTRALES. LA TRASERA CENTRAL SUPERIOR DEBE QUEDAR CASI A RAS CON LA CUBIERTA Y DEBE COMPARTIR LOS COSTADOS INTERIORES. ASEGÚRESE DE ESTO ANTES DE CLAVAR.



PRECAUCIÓN

DEL TOTAL DE CLAVOS (100 UNIDADES), OCUPE 80 UNID. PARA FIJAR LAS TRASERAS.

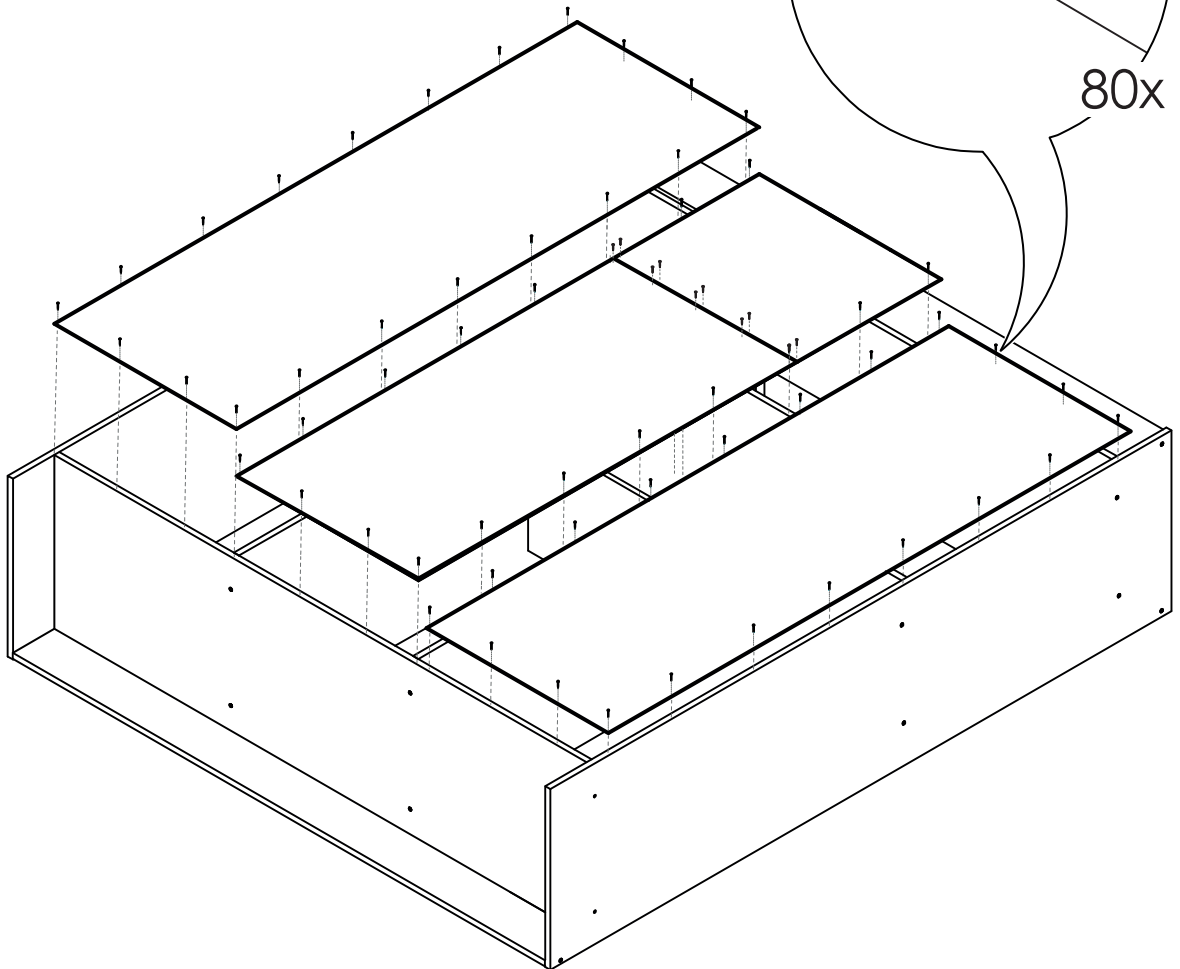
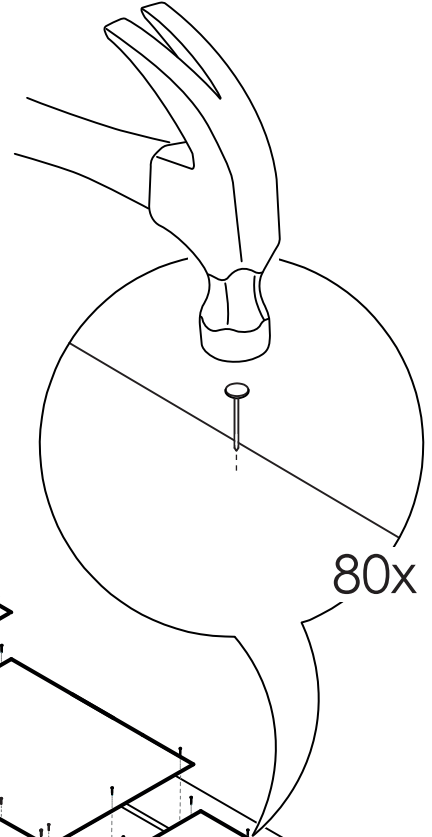

7

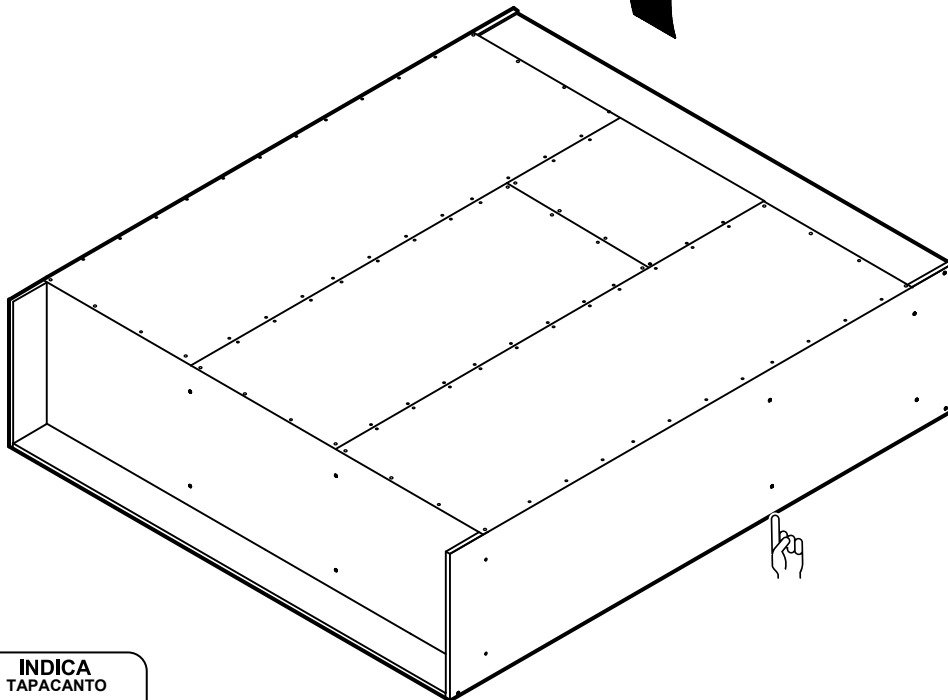
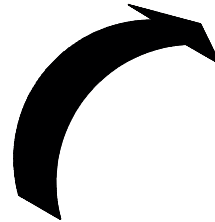
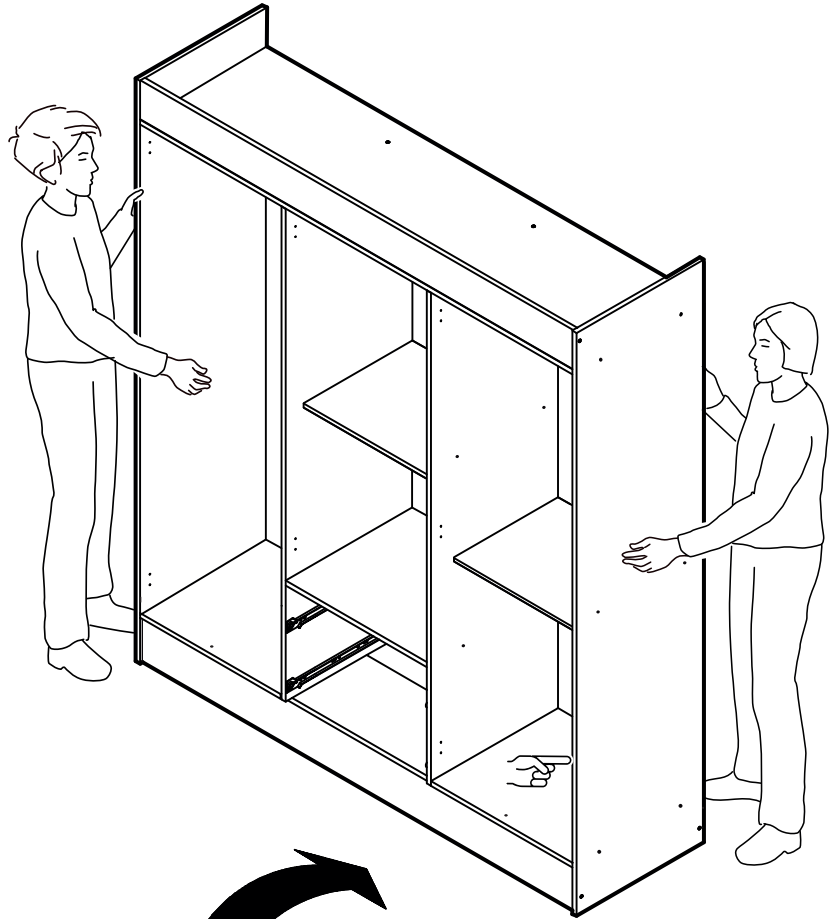

8

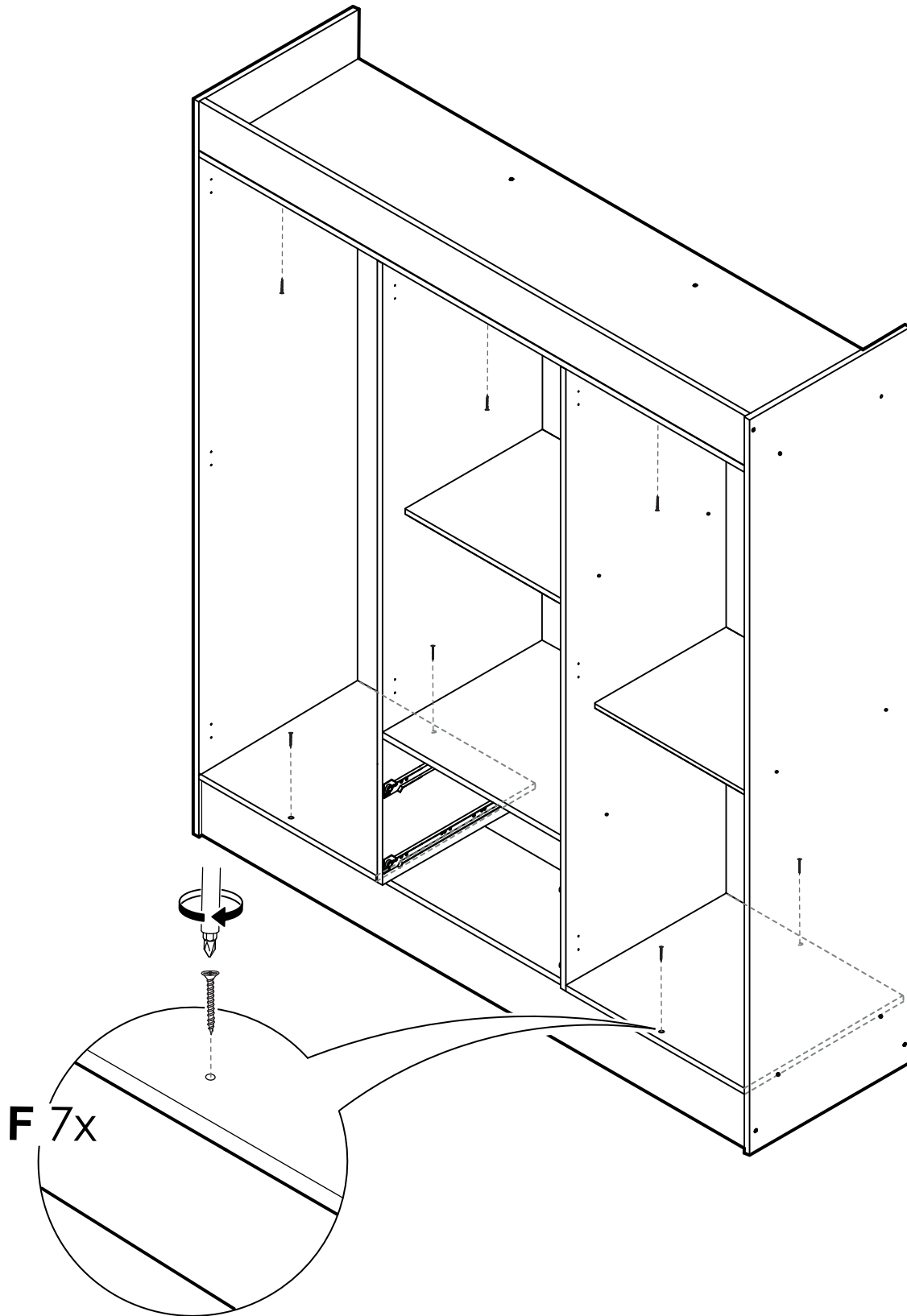

F 7x



9

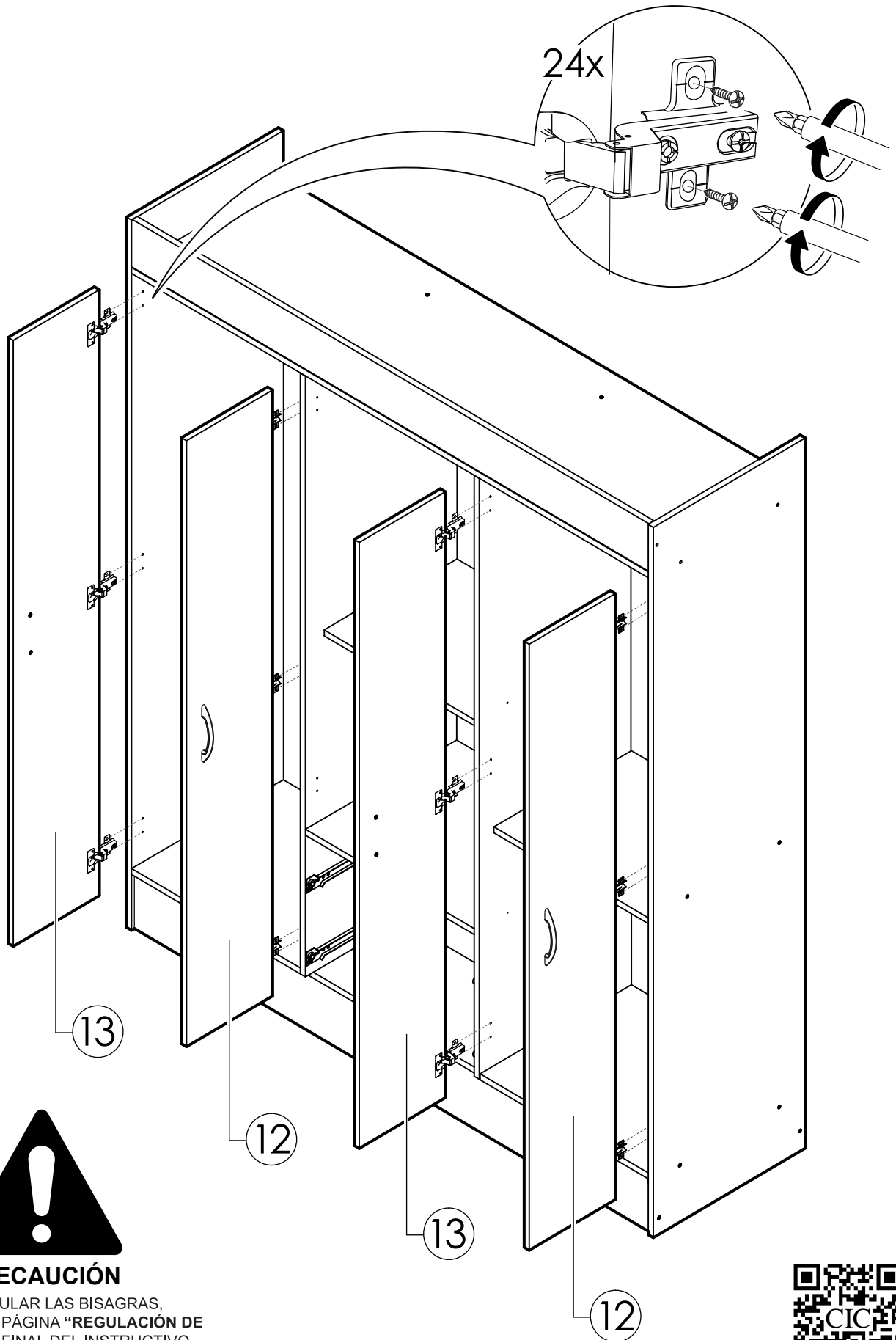

PRECAUCIÓN

PARA REGULAR LAS BISAGRAS,
CONSULTAR LA PÁGINA "REGULACIÓN DE
PUERTAS", AL FINAL DEL INSTRUCTIVO.



10

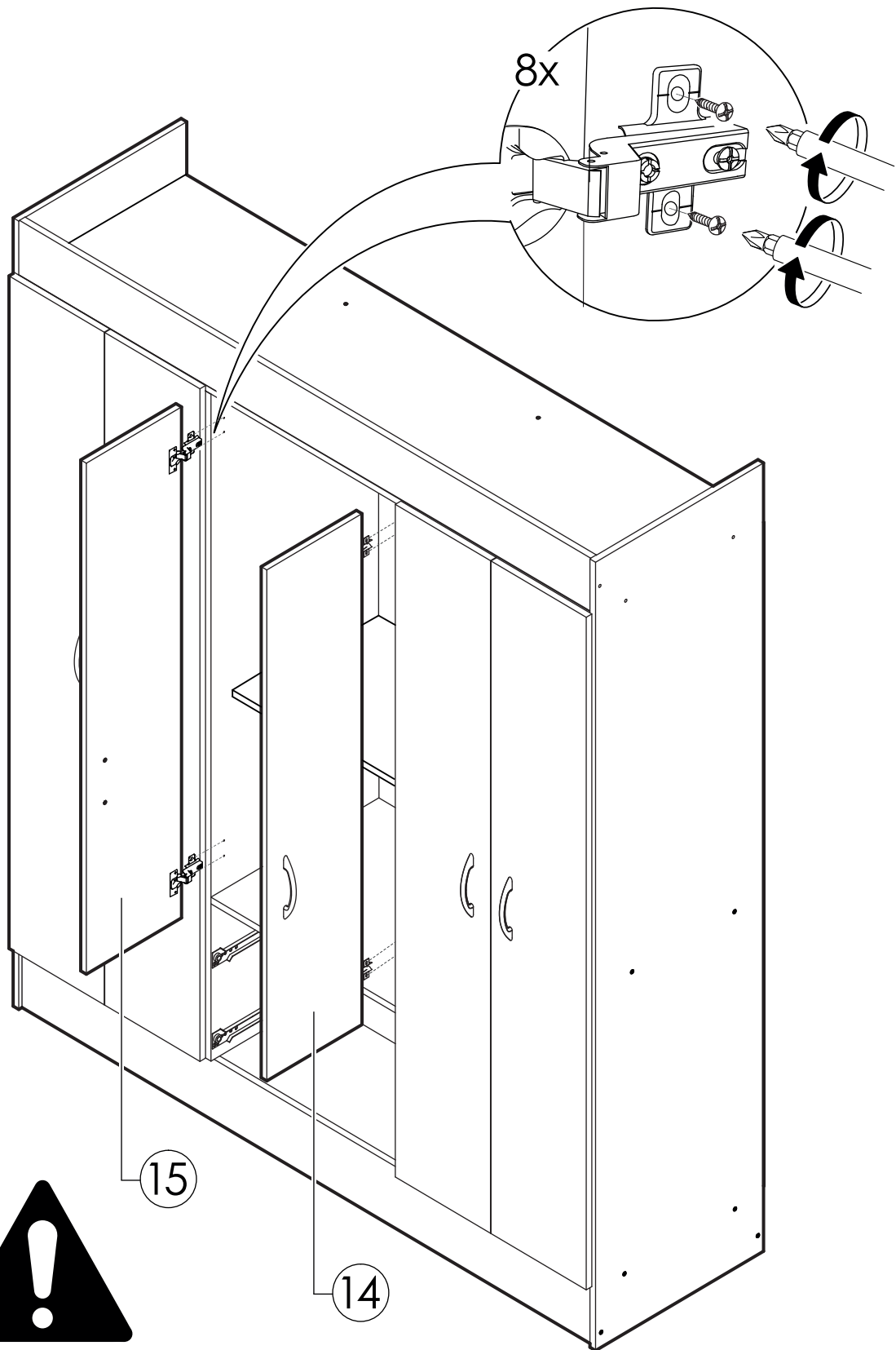

PRECAUCIÓN

PARA REGULAR LAS BISAGRAS,
CONSULTAR LA PÁGINA "REGULACIÓN DE
PUERTAS", AL FINAL DEL INSTRUCTIVO.



11

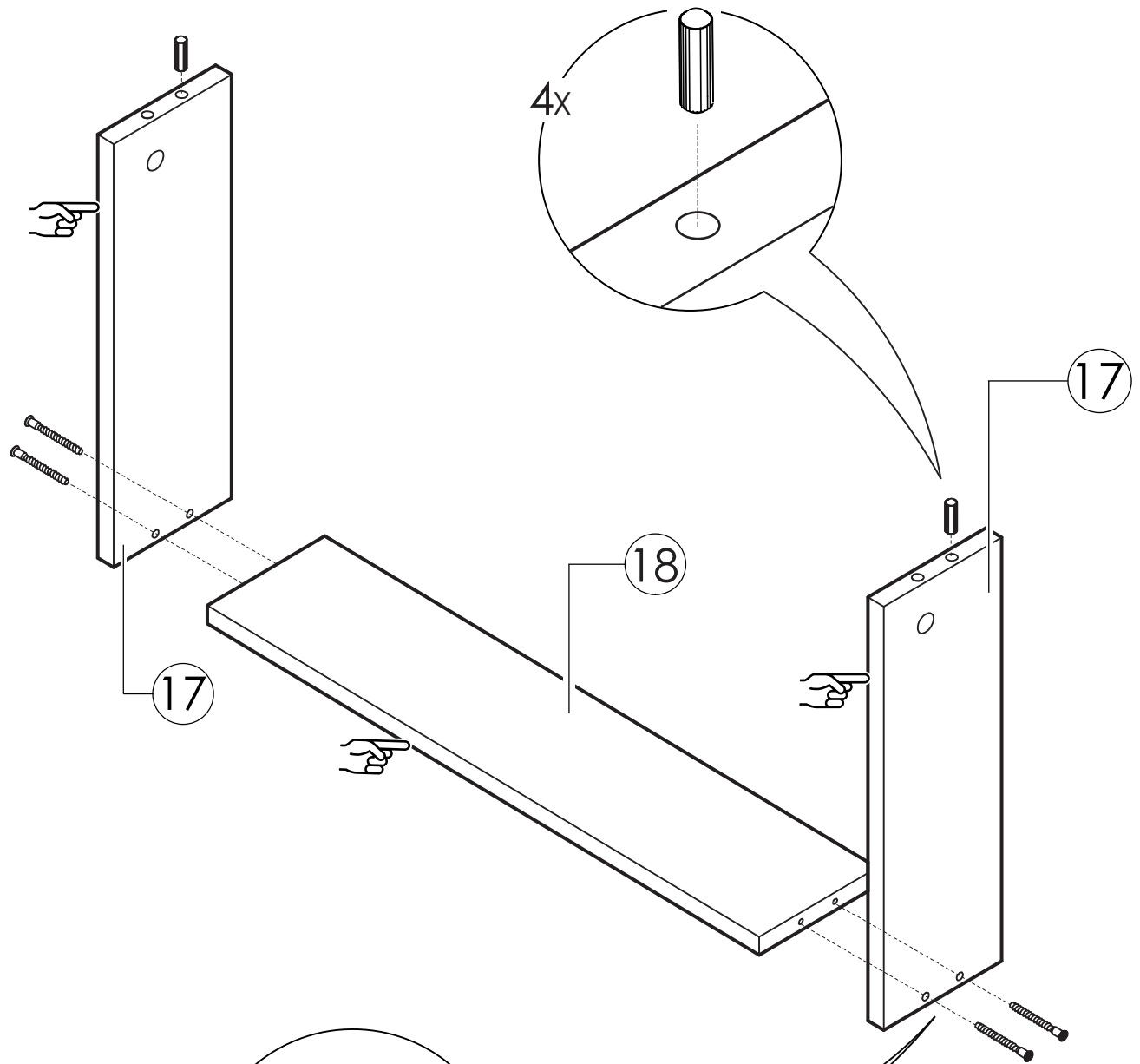

M 8x

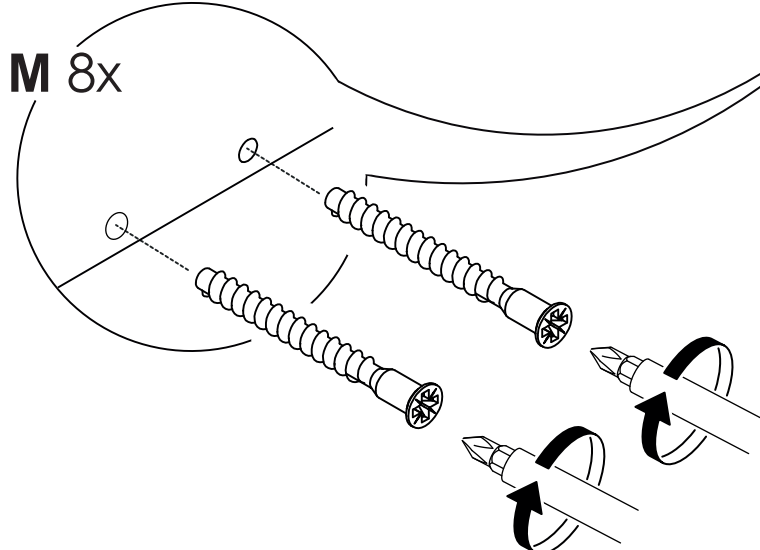

12

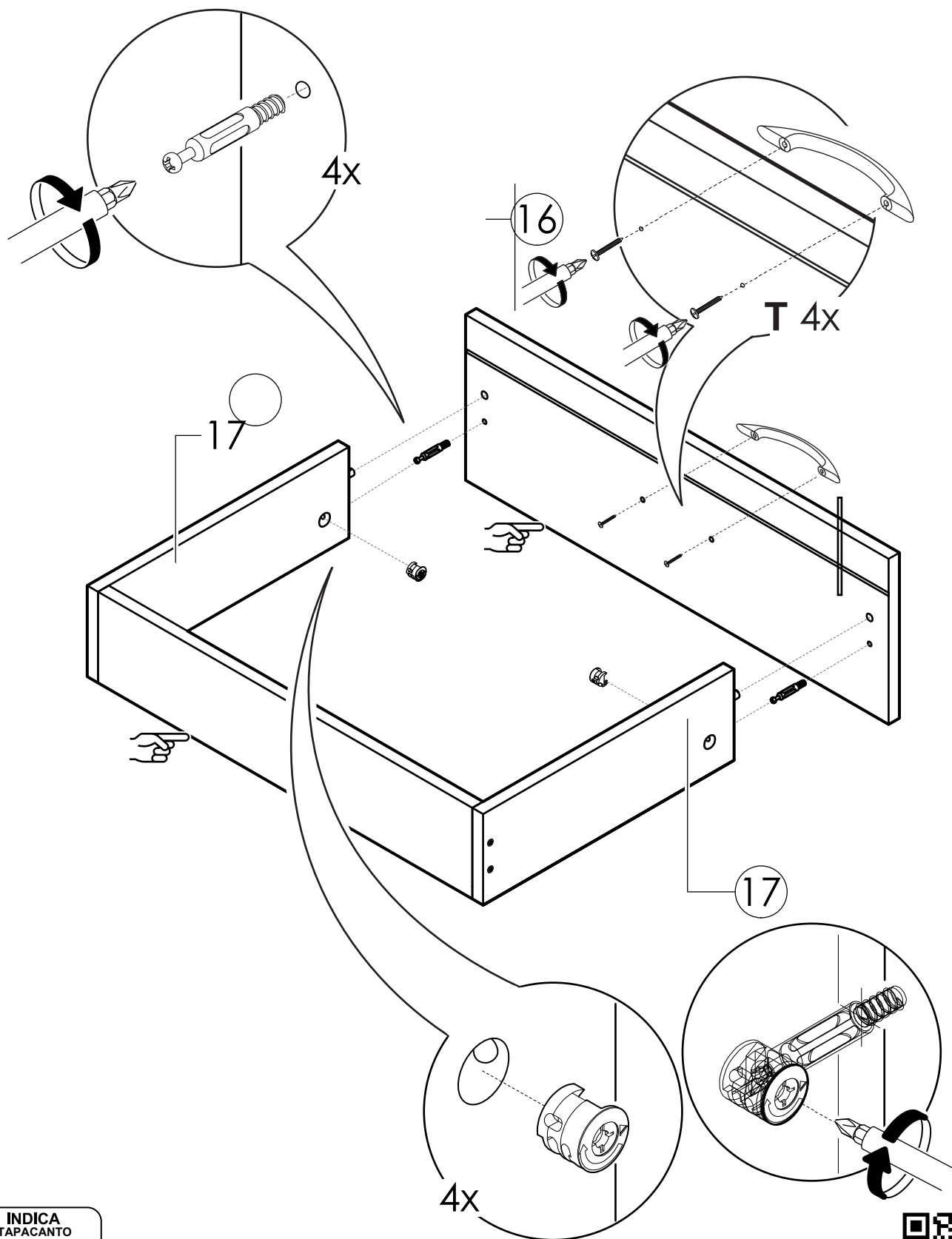

13

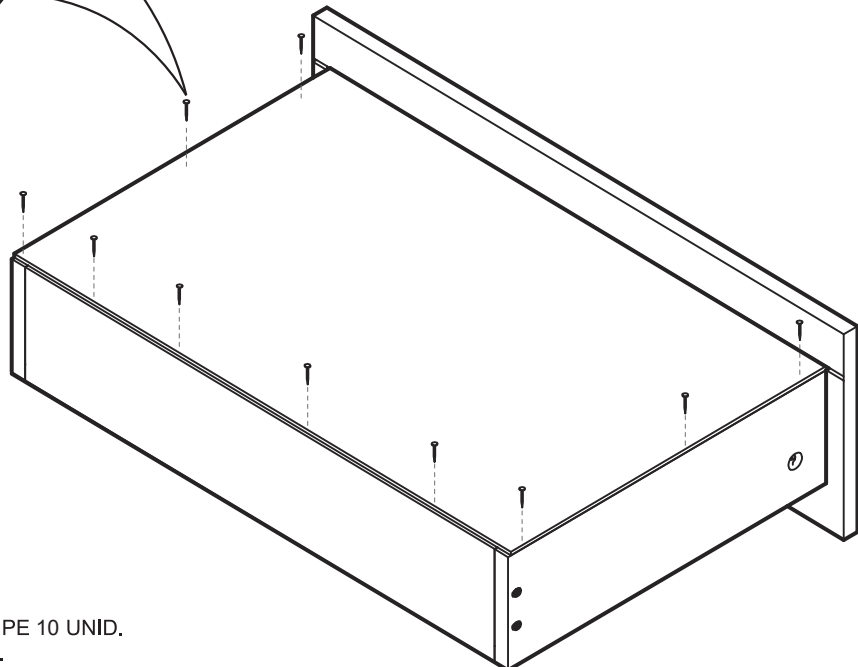
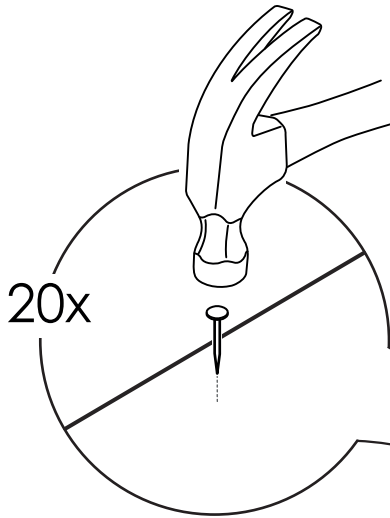
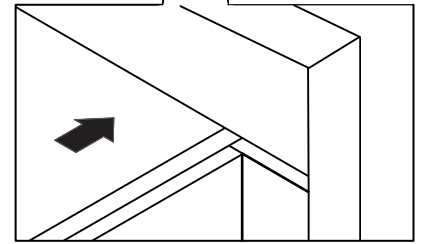
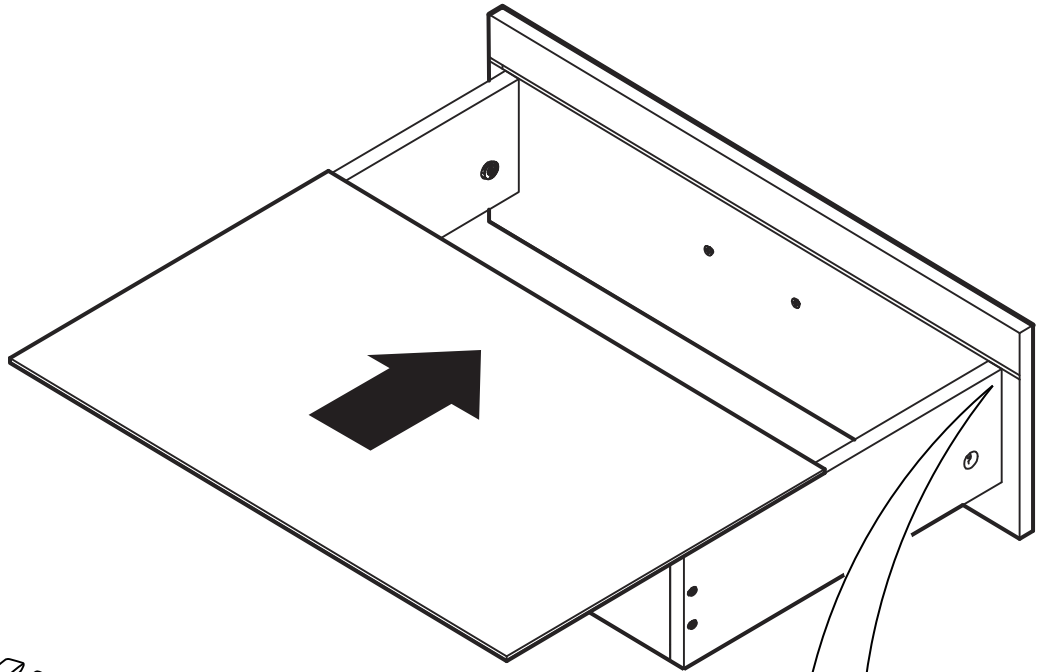

PRECAUCIÓN

DE LOS 20 CLAVOS RESTANTES, OCUPE 10 UNID.
PARA FIJAR CADA FONDO.



14



PRECAUCIÓN

CON MARTILLO Y CLAVO REALICE
ENCAMINADOS EN EL FONDO DE CAJÓN.

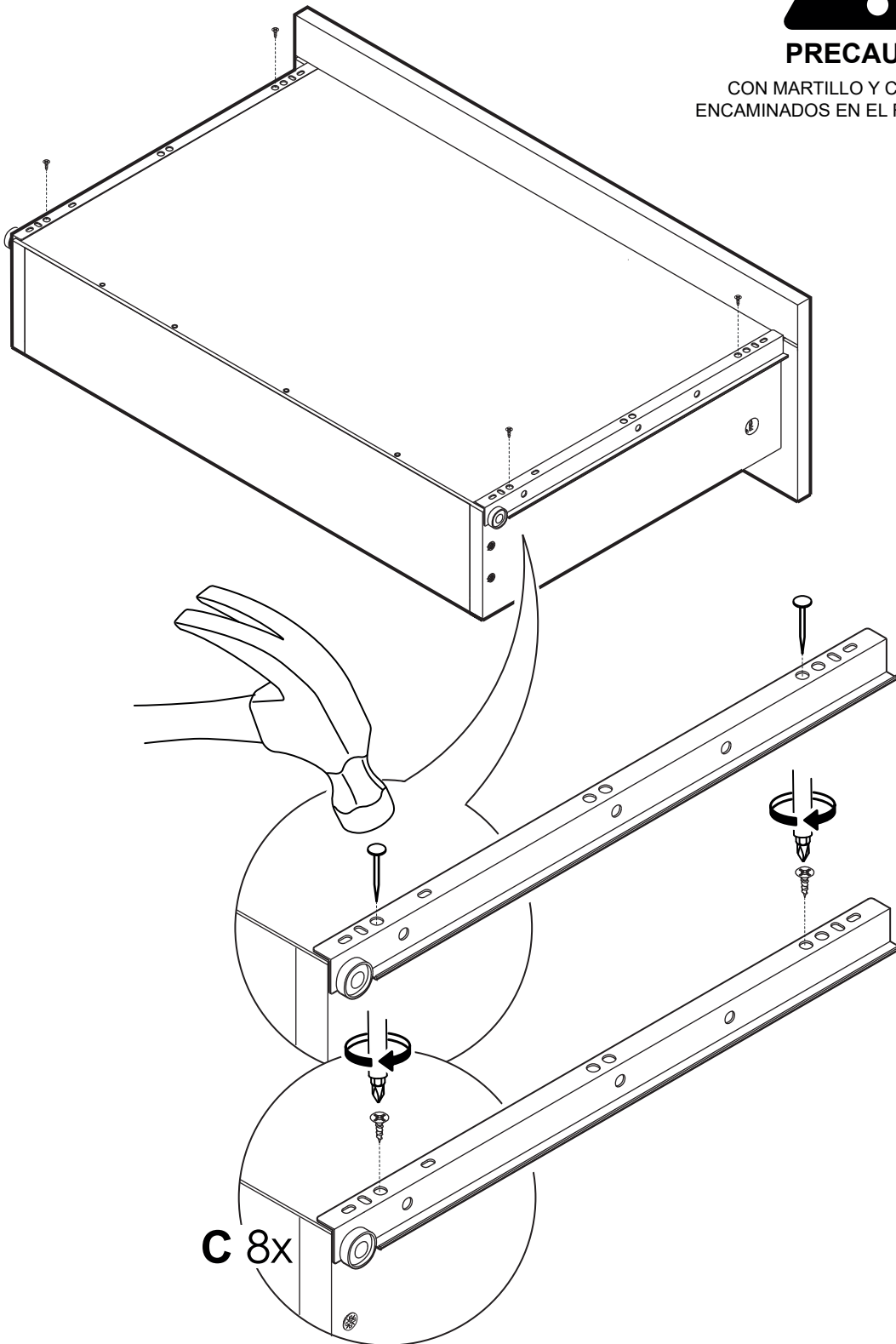

15

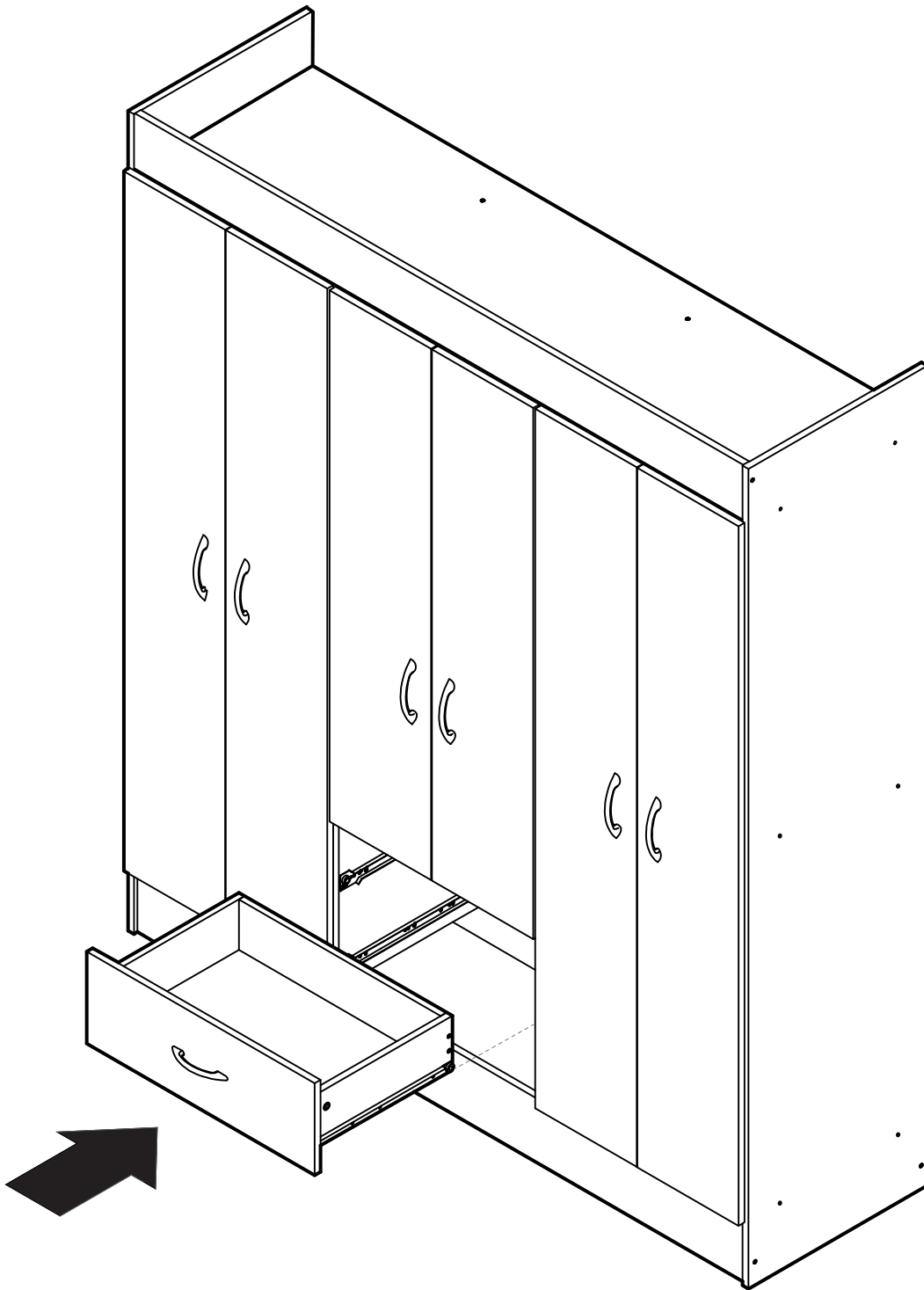

16

