

STA 0.00

STA 83.00

STA 683.45

STA 16.70

STA 683.45

17 PITCHES AT 30.0" = 510.0 (R/H ONLY)

10 PITCHES AT 31.0" = 310.0 (L/H ONLY)

9 PITCHES AT 30.0" = 270.0 (L/H ONLY)

DETAIL 'F'
TYPE II EMERGENCY EXIT CLEARANCE ENVELOPE

DETAIL 'B'
TYPICAL SEAT TO BULKHEAD CLEARANCES (SEE SHT 3)

DETAIL 'C'
TYPICAL SEAT ARRANGEMENT (SEE SHT 3)

DETAIL 'E'
TYPICAL PSU ARRANGEMENT (SEE SHT 3)

	SEAT UNSUITABLE FOR H/CAP PAX	---
	SEAT WITH IN ARM TRAY	IAT
	SEAT WITH BABY HAMMOCK	BBY HMK
	HANDICAP ARM REST	H/CAP
	SEAT WITH NO BREAK OVER	NO B/OVR
	SEAT WITH LIMITED RECLINE	LTD REC
	SEAT WITH NO RECLINE	NO REC

DRAWING NUMBER	SHT No.	No. of SHTS	ISSUE
AIC252JC1950	2	3	A

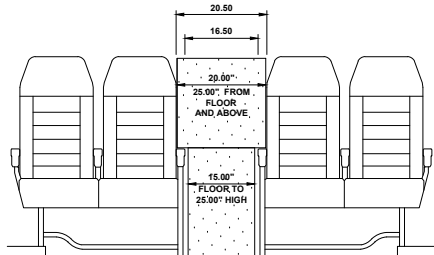

SECTION 'A-A' - WIDTH OF AISLE
CONSTANT SECTION (B/E AEROSPACE 945-12K-2 / 945-12L-2 / 945-12A-2 / 945-12E-2 SEATS)

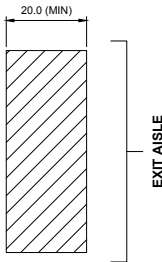

TYPICAL TYPE I & II DOOR EXIT AISLE

ASSIST SPACE IS NOT REQUIRED AS THE EXITS ARE LESS THAN 1.80 METERS OFF THE GROUND.

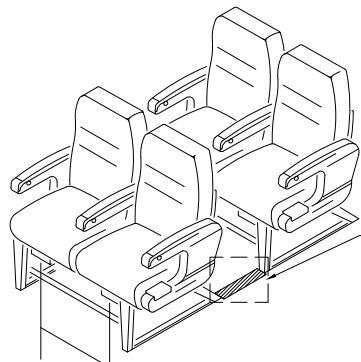

DETAIL 'C'
TYPICAL SEAT FURNISHINGS
(R/H DOUBLE SEAT SHOWN - L/H SEATS SIMILAR)

DETAIL 'D'
TYPICAL SEAT TRACK COVER INSTALLATION

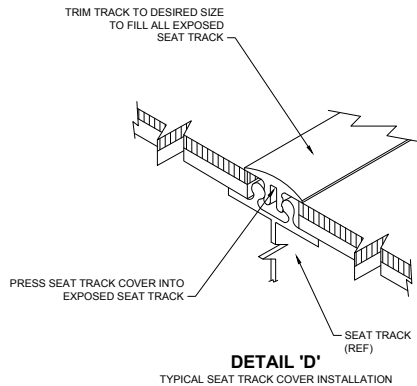

TYPE II FWD EMERGENCY EXIT

STA 83.00

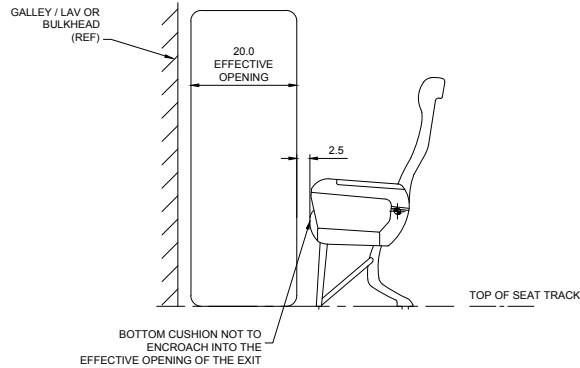

DETAIL 'F'
TYPE II EMERGENCY EXIT CLEARANCE ENVELOPE

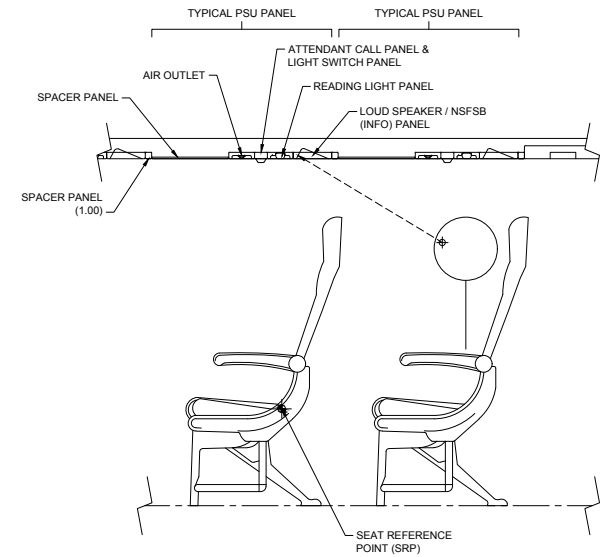

DETAIL 'E'
TYPICAL PSU ARRANGEMENT

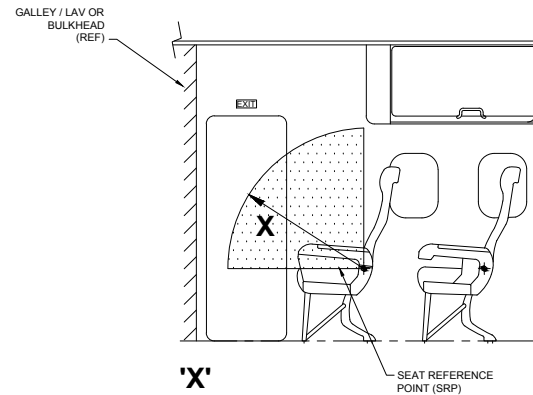

'X'
MINIMUM REQUIRED BULKHEAD CLEARANCE
889.0mm (35.00)
(MEASURED FROM SEAT REFERENCE POINT)

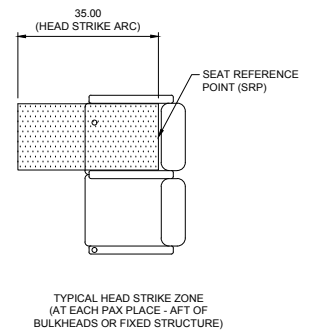

DETAIL 'B'
TYPICAL SEAT TO BULKHEAD CLEARANCES

DRAWING NUMBER	SHT No.	No. of SHTS	ISSUE
AIC252JC1950	3	3	A