

**MEGA  
CONSTRUX**

# HALO

HALO  
INFINITE

GYG60



**2 in 1\***  
EM / B



\*Instructions included for main model only. Other build(s) can be found at [megaunboxed.com](http://megaunboxed.com) / Instructions incluses pour le modèle principal uniquement.  
Les instructions pour l'(les) autre(s) modèle(s) de construction se trouvent sur le site [megaunboxed.com](http://megaunboxed.com)



Scan here for instructions

Scanner ici pour obtenir les instructions

Escanee aquí para obtener instrucciones  
Digitalize aquí para instruções  
Hier scannen und Anleitung aufrufen  
Просканируйте здесь для получения инструкций

[megaconstrux.com](http://megaconstrux.com)

Choose your Build  
Choisissez votre construction

Elige tu armado • Escolha sua montagem  
Wähle dein Modell • Выбери свою конструкцию



Most models can be built one at a time. / La plupart des modèles peuvent être construits un à la fois. / La mayoría de modelos se pueden construir de uno en uno. / A maioria dos modelos pode ser construída separadamente. / La maggior parte dei modelli possono essere realizzati uno per volta. / Die meisten Modelle können eines nach dem anderen gebaut werden. / Większości modeli nie da się budować jednocześnie z innymi. / De meeste modellen kunnen één voor één gebouwd worden. / Большинство моделей могут быть собраны по одной за раз. / De fleste modeller kan bygges enkeltvis. / De flesta modeller kan byggas en i taget. / De fleste modellene kan bygges en om gangen. / Useimmat mallit voidaan rakentaa yksi kerrallaan. / Τα περισσότερα μοντέλα μπορούν να κατασκευασθούν ένα ένα. / Modellerin çoğu ayrı ayrı inşa edilmeyi gerektirebilir. / Většinou lze nejednou sestavit pouze jeden model. / Väčšina modelov môže byť zostavená iba raz. / A modellek többségéből egyszerre csak egy építhető. /ほとんどのモデルは、一度に一つを組み立てることができます。 / 大多數型號可一次性建構



# BUILDING TOOL OUTIL DE CONSTRUCTION

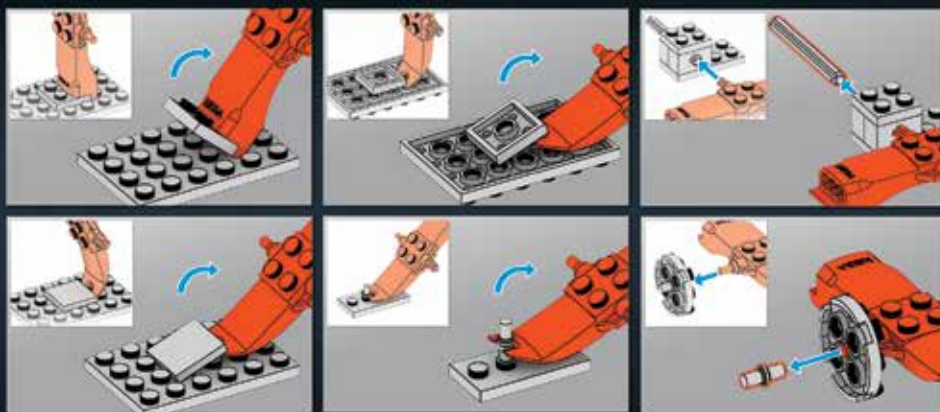

HERRAMIENTA DE CONSTRUCCIÓN / BAUWERKZEUG / FERRAMENTA DE MONTAGEM / ИНСТРУМЕНТ ДЛЯ КОНСТРУИРОВАНИЯ



1



1

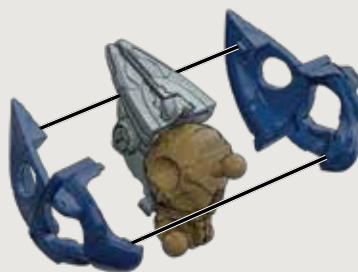

2



3



1



2

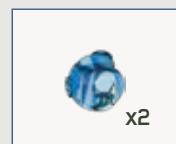

x2



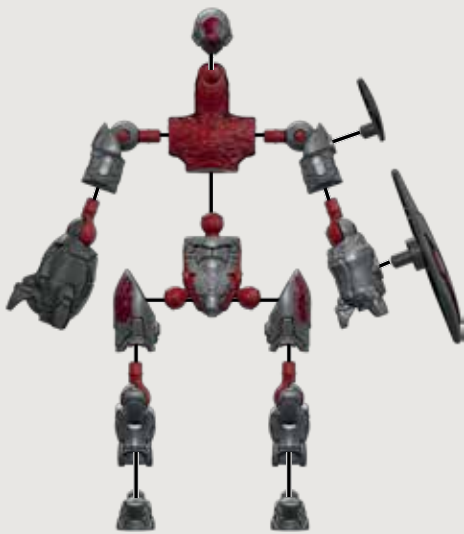

1

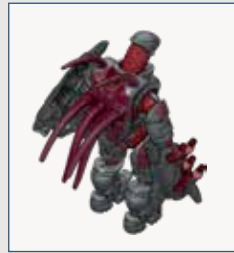

2



3

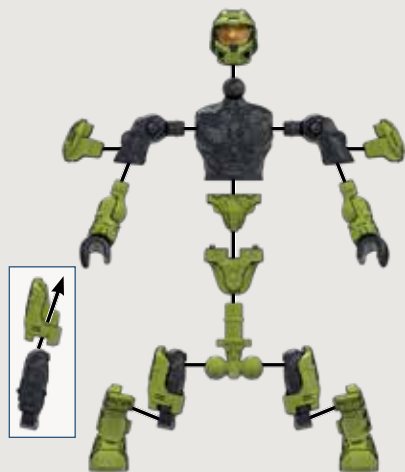

1

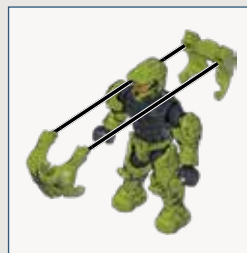

2



1

2



**2**

6X	1X	1X

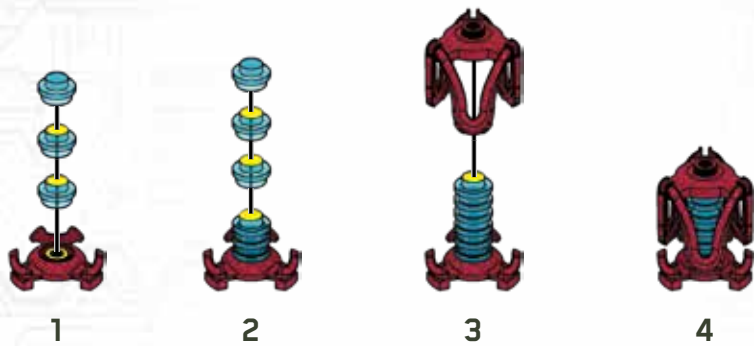

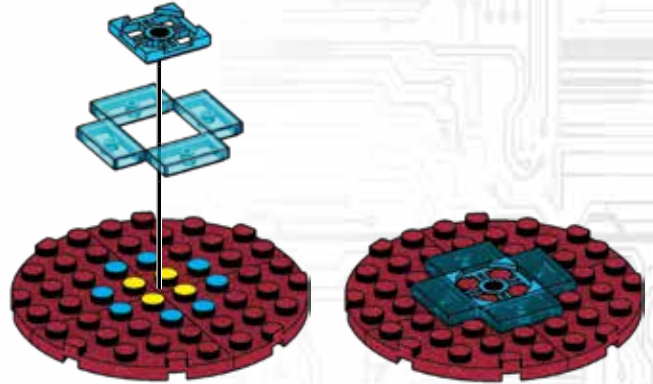
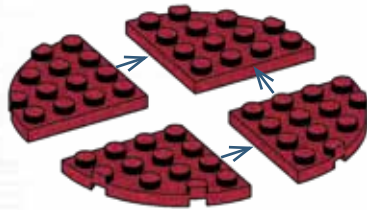
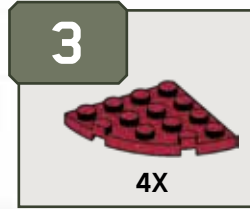

1

2

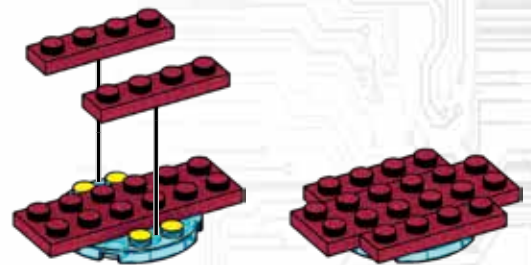
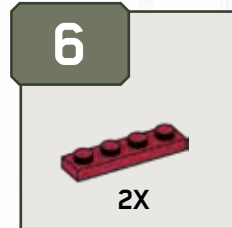
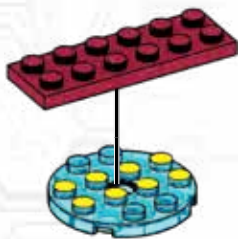
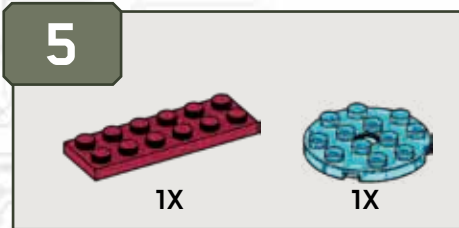

1

2

7

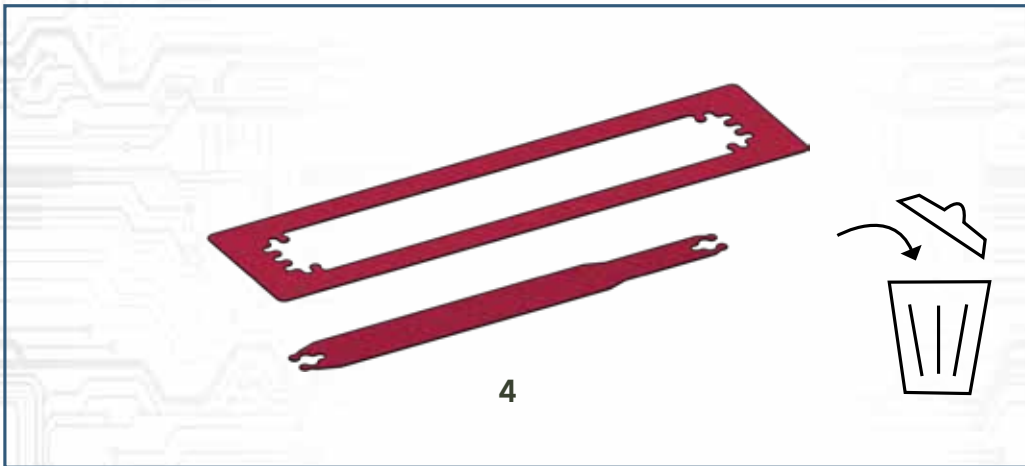
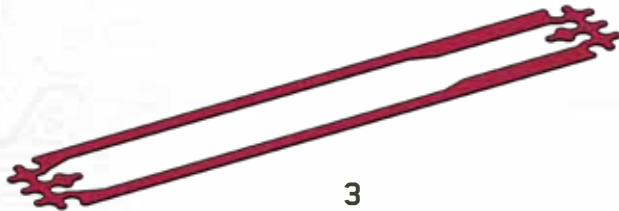
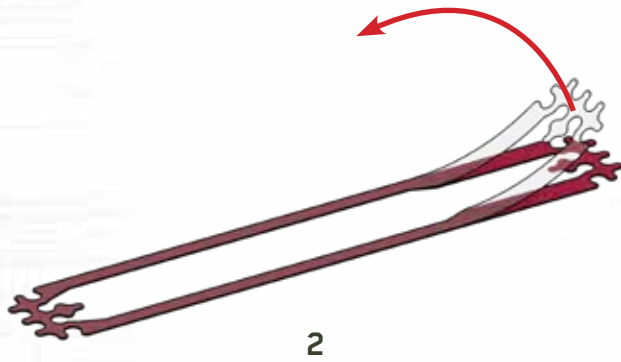
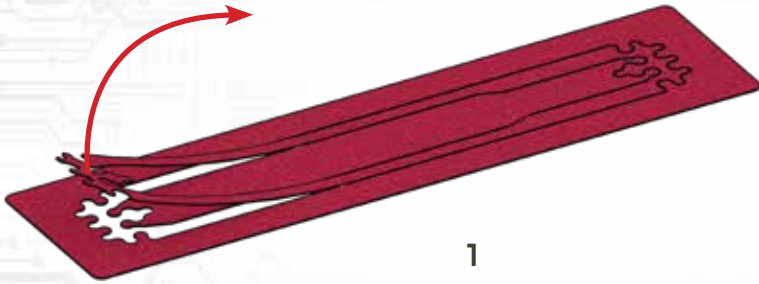
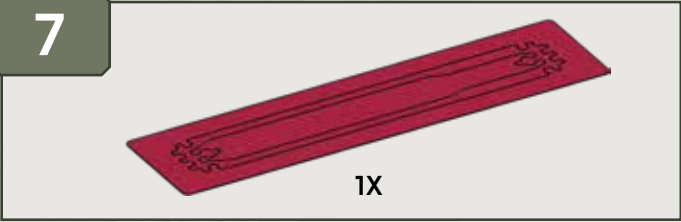

8



1X

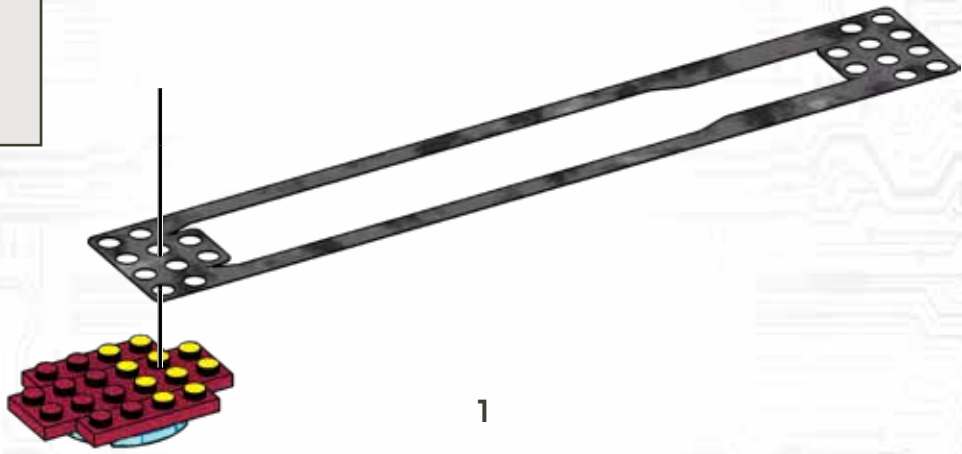

1

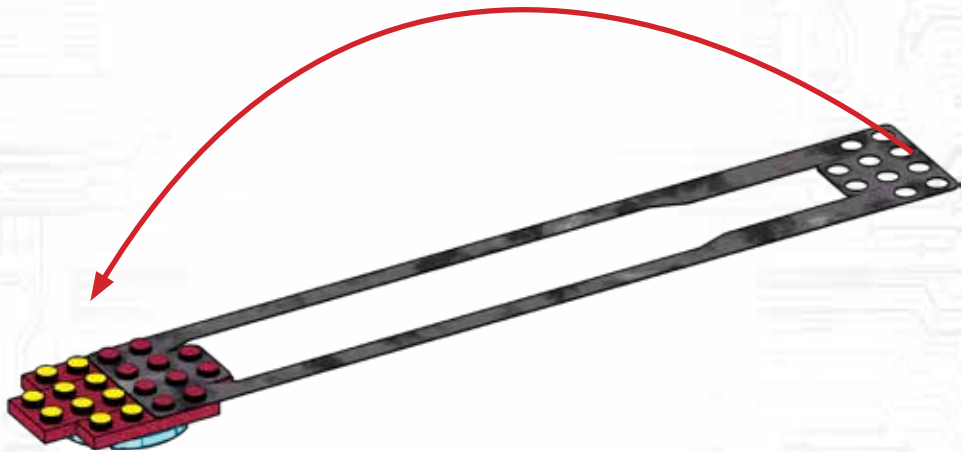

2



3



9



1X

2X

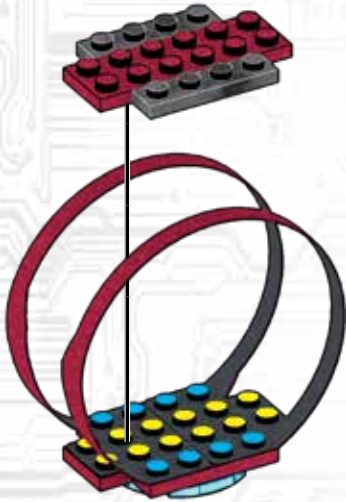

10



1X

1X



1



2

11



1X

1X



12



2X

1X



13



2X

1X



14

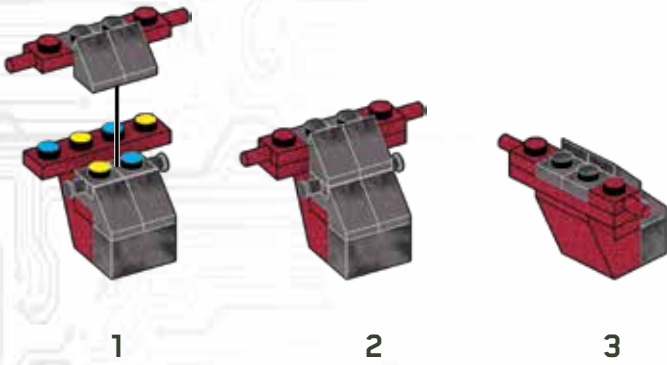

15



16

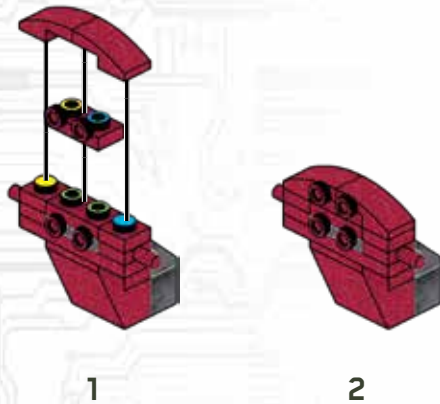

17

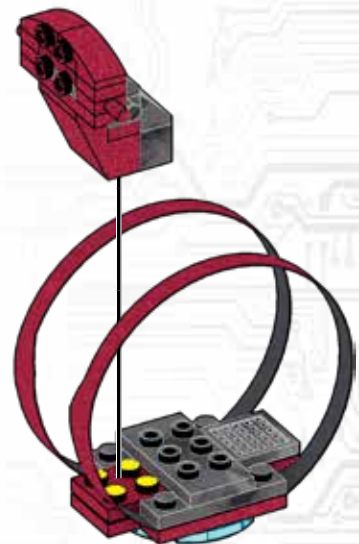

18



1X

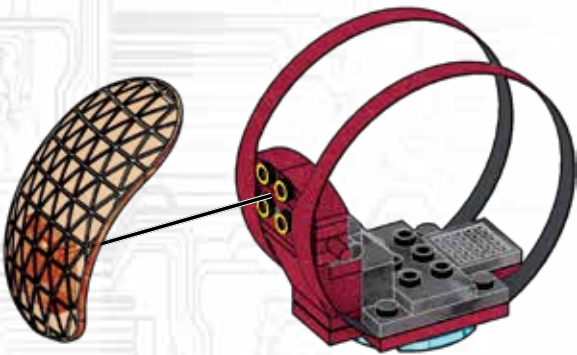

1

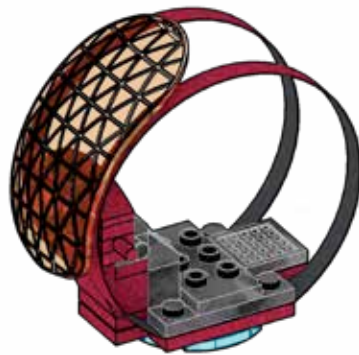

2



3

19



2X

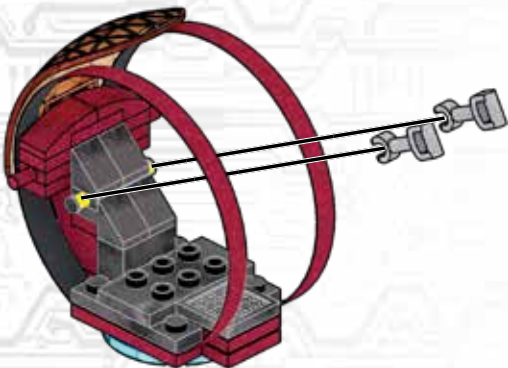

1

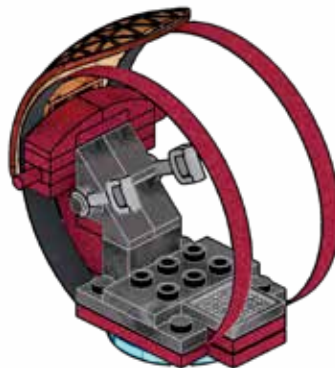

2

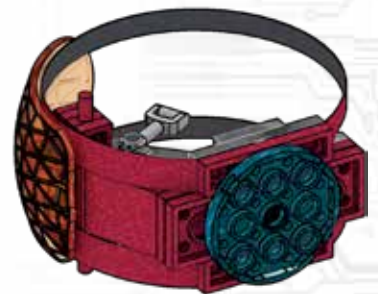

3

20



1X

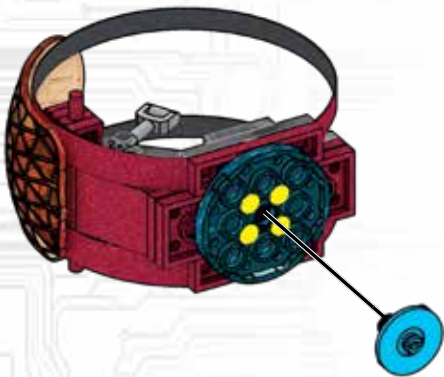

1

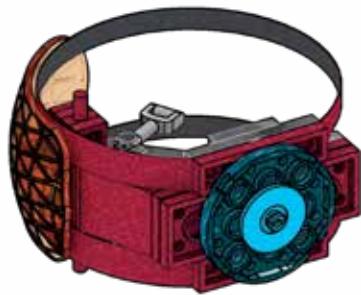

2



3

21

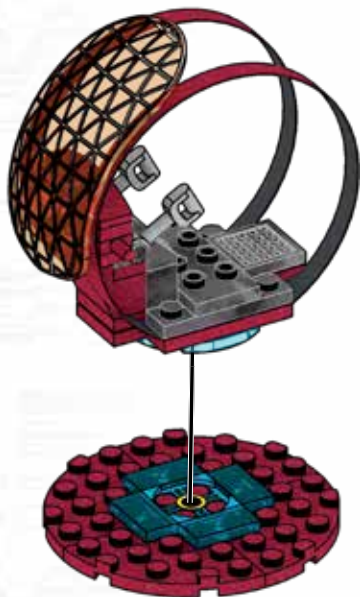

1

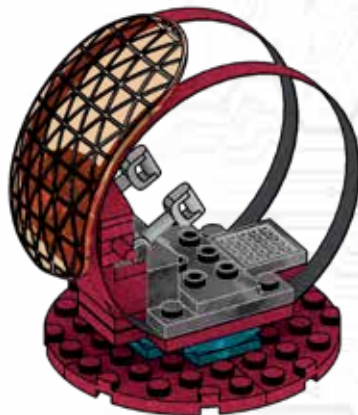

2

x2

22

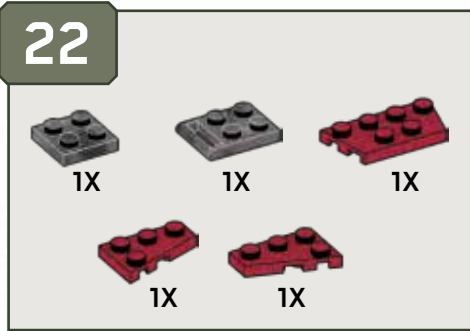

1X 1X 1X  
1X 1X



23



1X 1X



1



2



3

24



1X 1X



25



1X

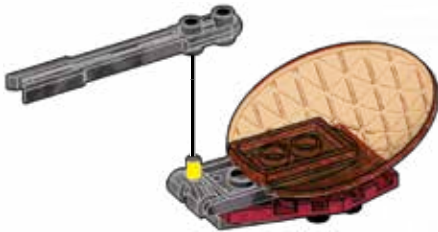

1



2

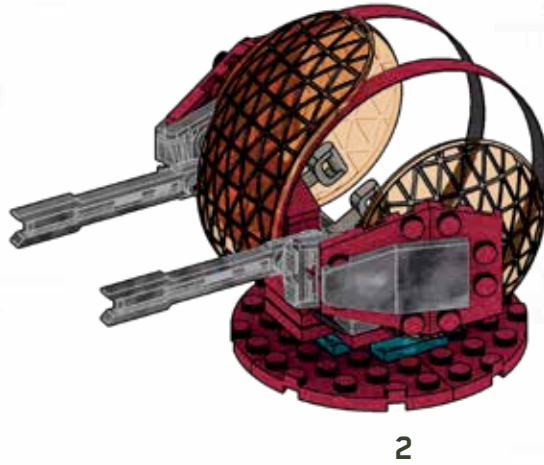
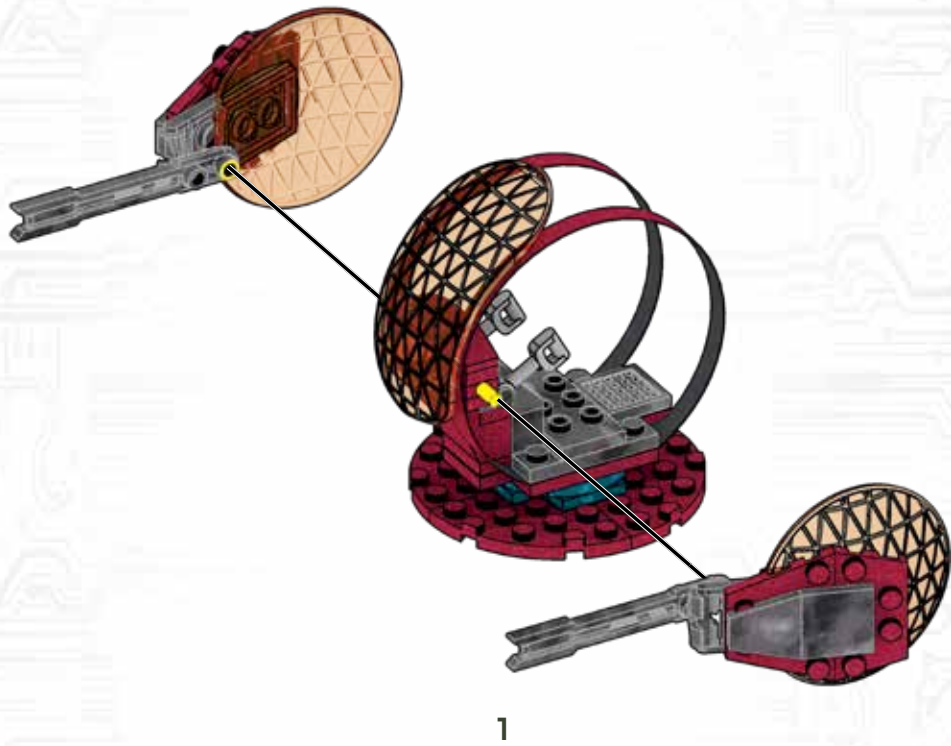

1

2

or / ou / o / oder / lub  
of / или / ή / veya / أو

27

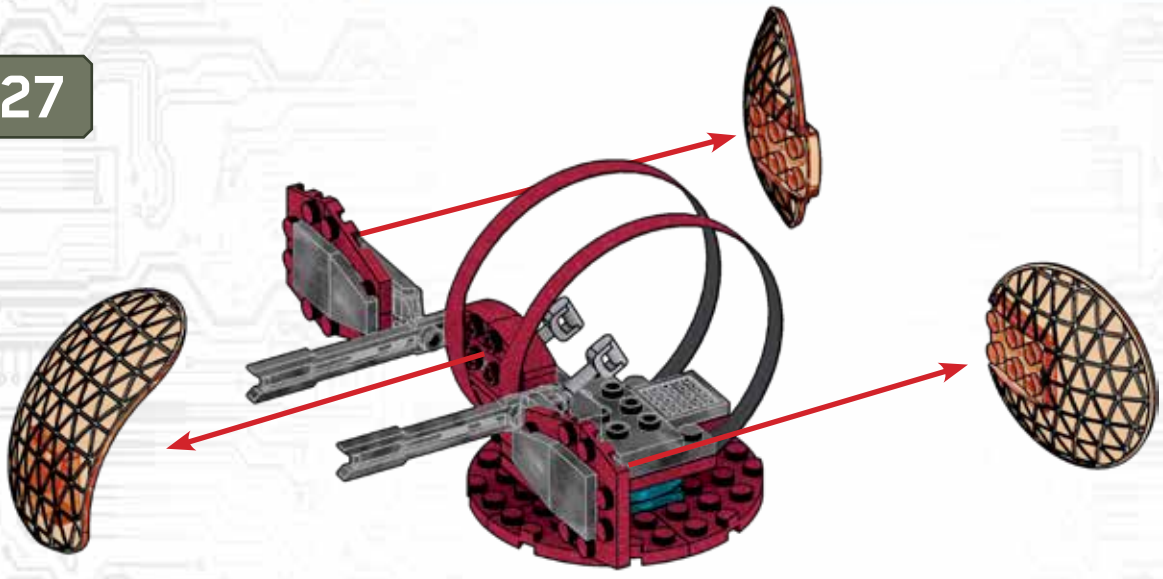

1

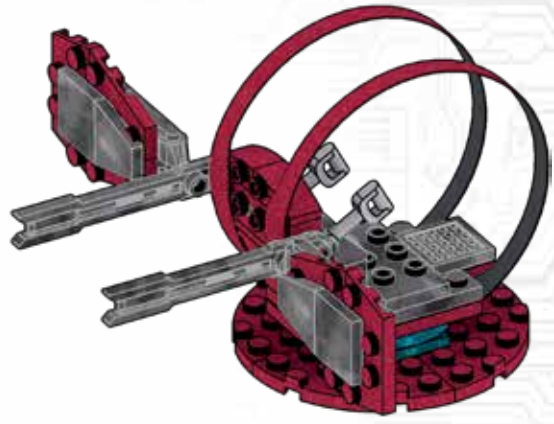

2

28

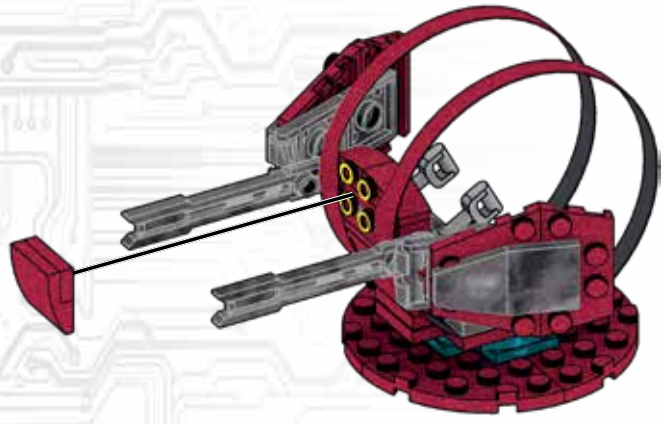
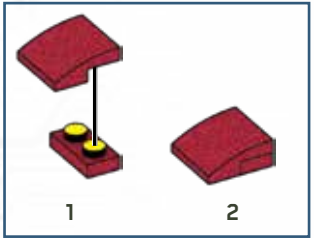

1

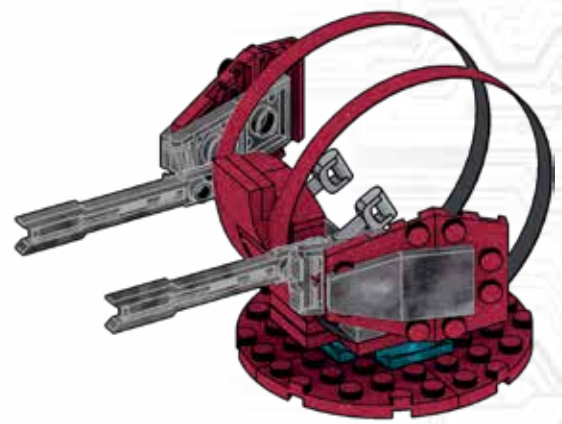

2



29



2X



1X



1X



30



1X

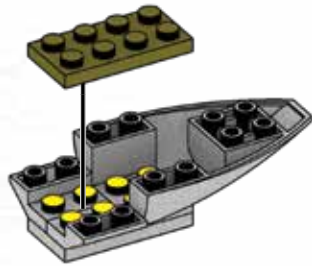

1



2

31



2X



4X



1X



32



2X





33

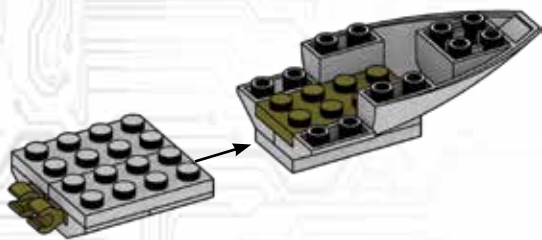

34

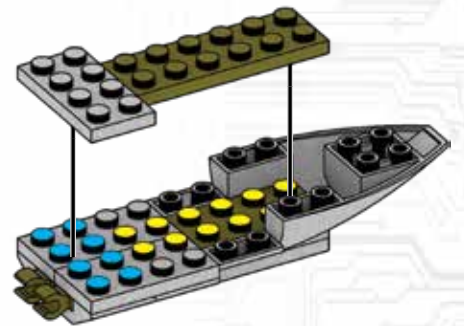
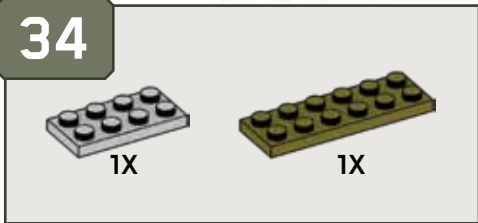

35

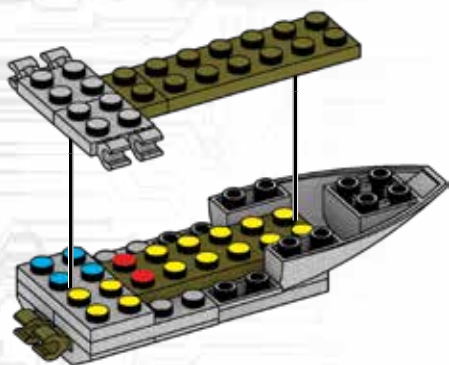
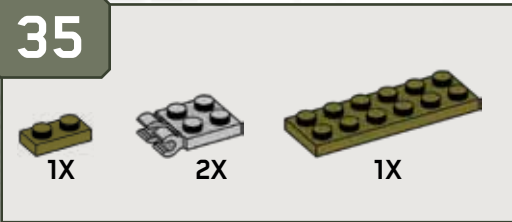

36

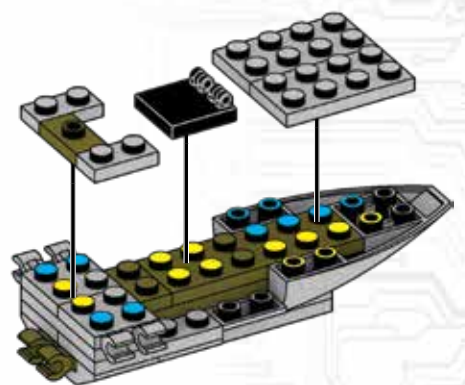
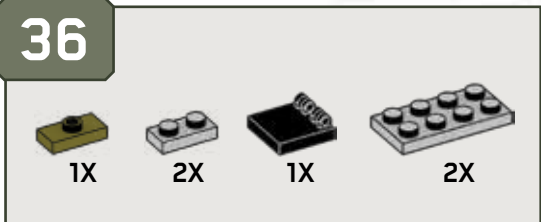

37



4X

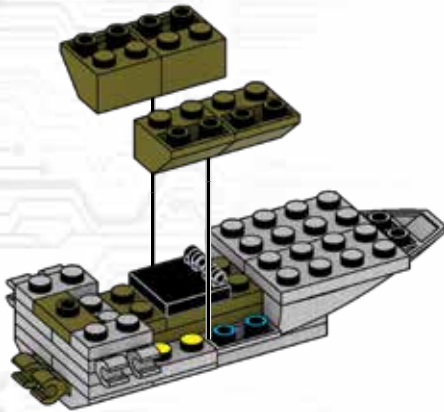

38



1X



2X

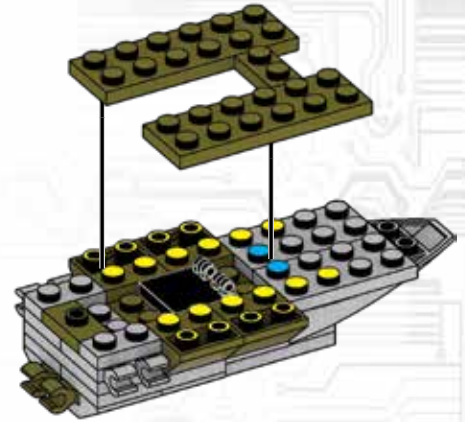

39



2X



2X

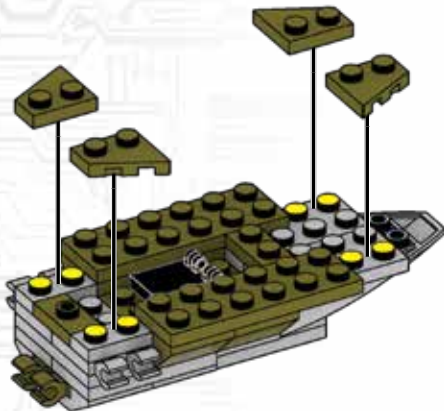

1

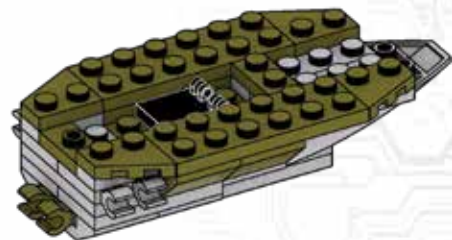

2

40

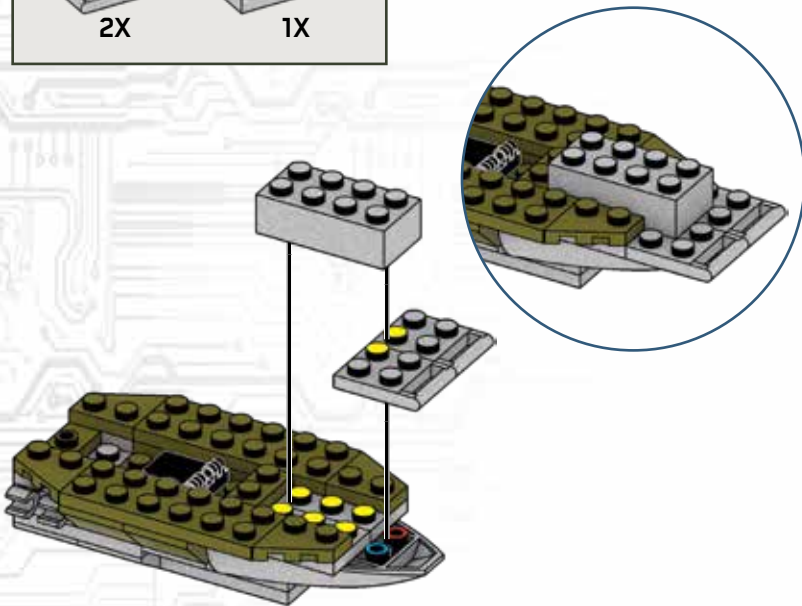
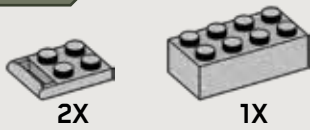

41

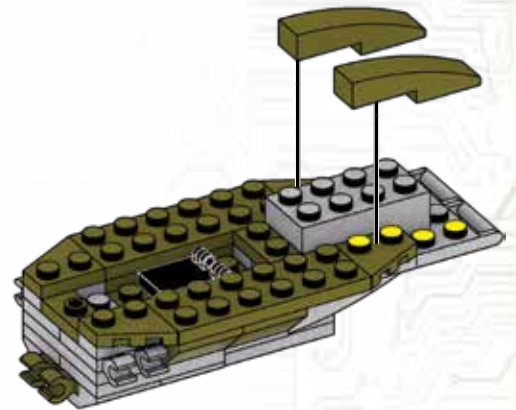

42

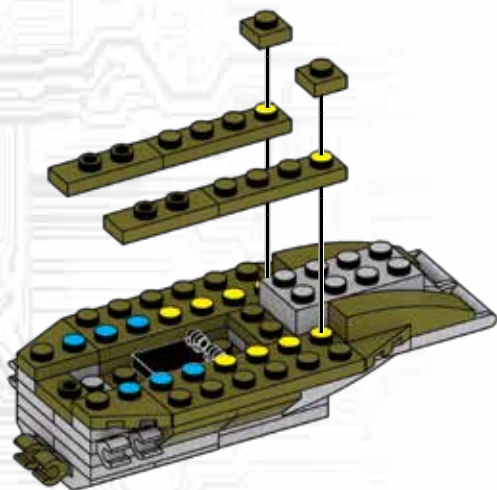

43

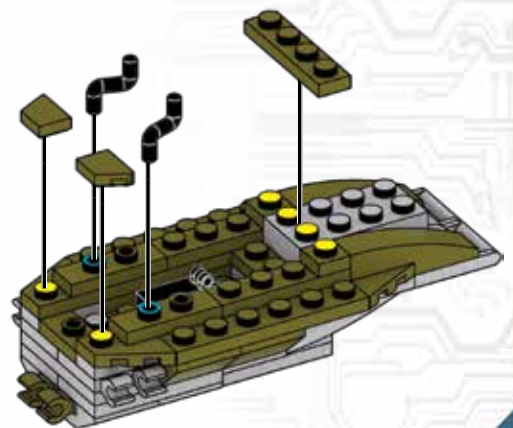

44



6X

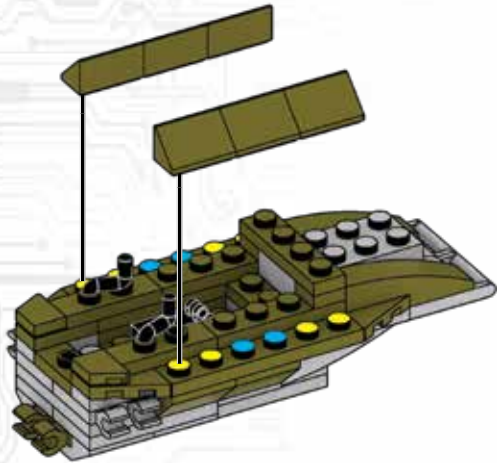

45



2X



1X

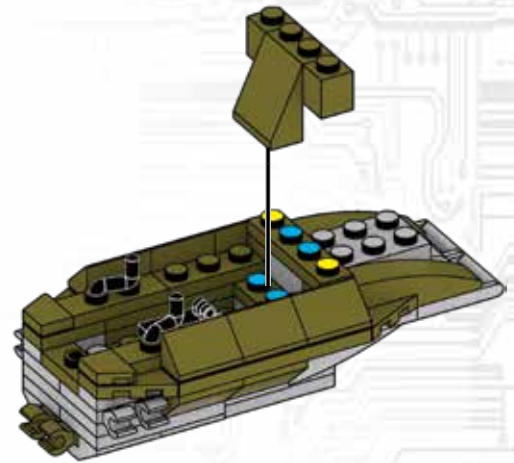

46



1X



1X



1X

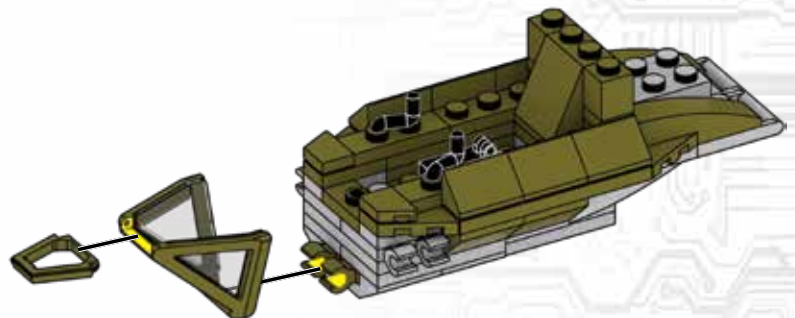

47



1X



1X



1X



1X

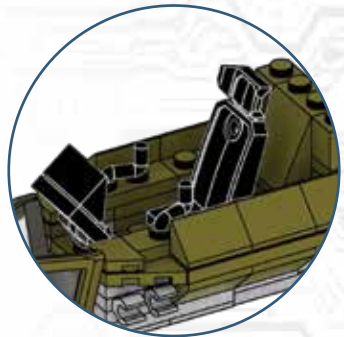
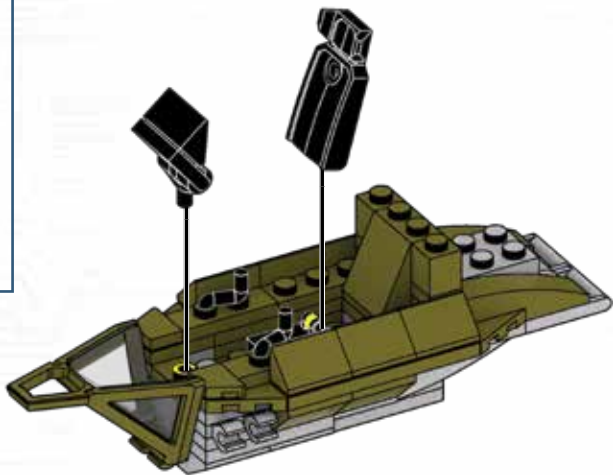
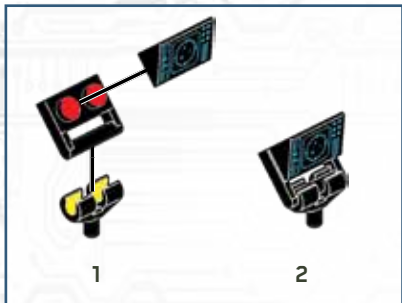

48



2X



2X

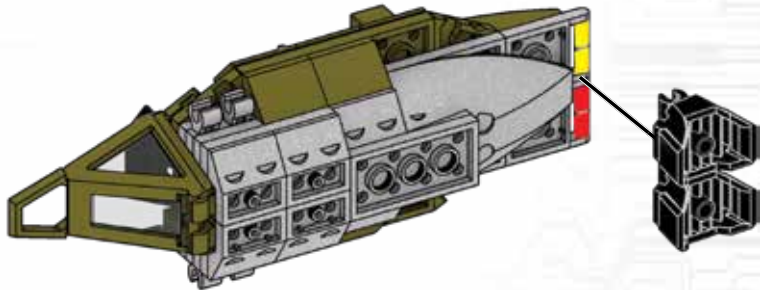
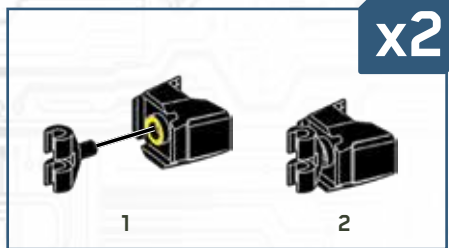

49



2X



2X



2X

x2

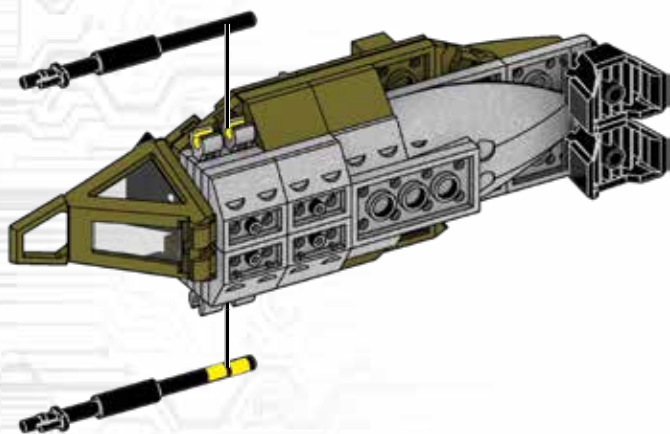
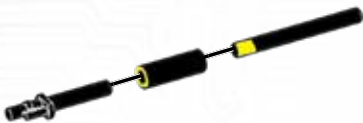

1

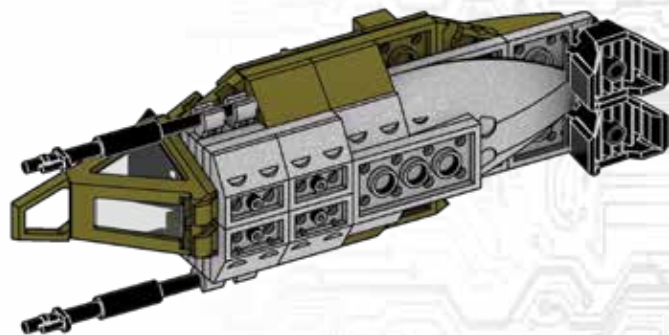

2

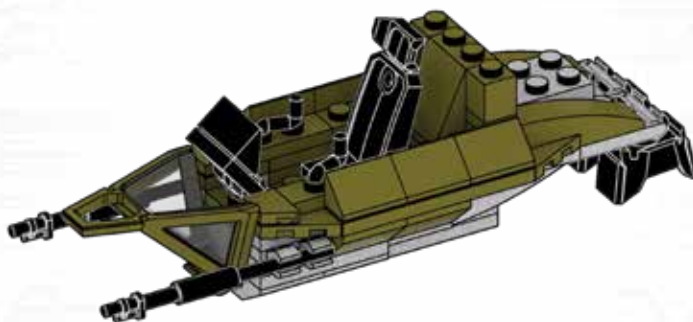

3



**50**

1X      2X

1X

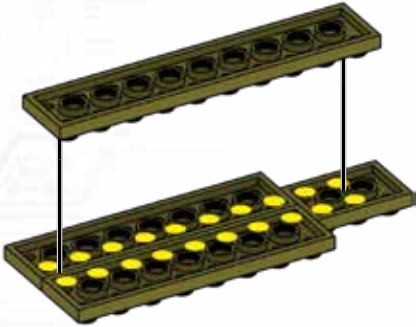

**51**

2X

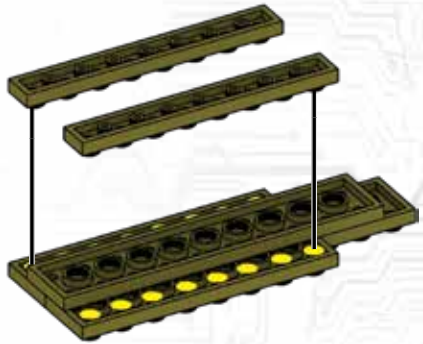

**52**

2X      1X

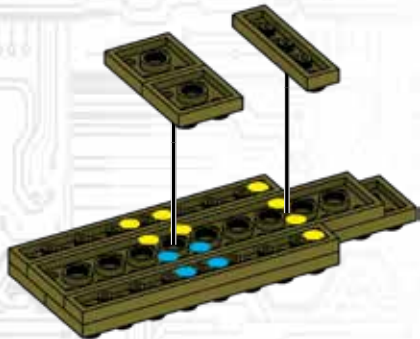

**53**

8X

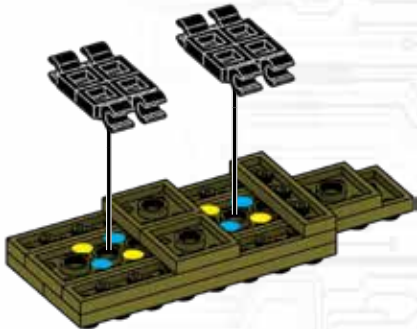

54

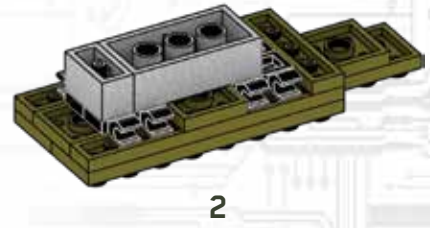
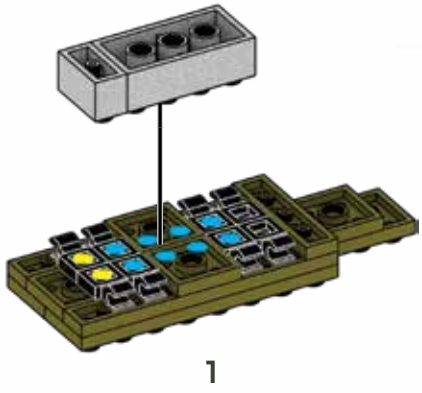
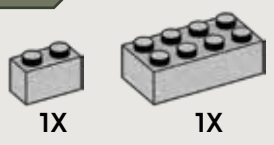

55

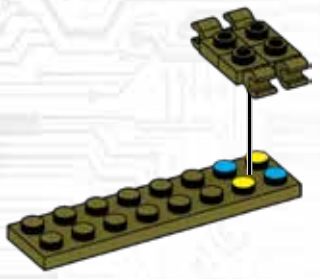
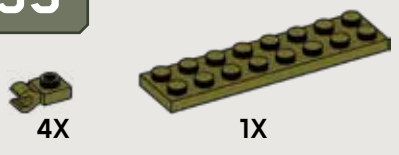

56

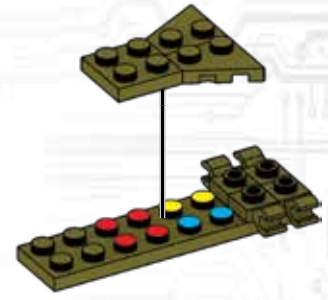

57



58

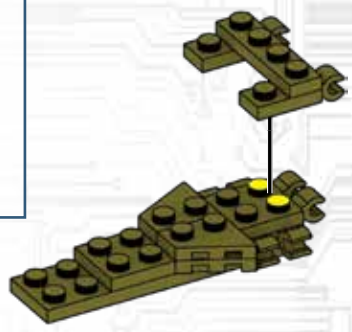
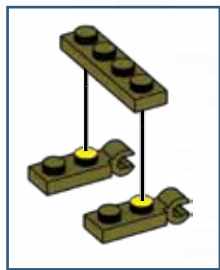



59



1X

1X

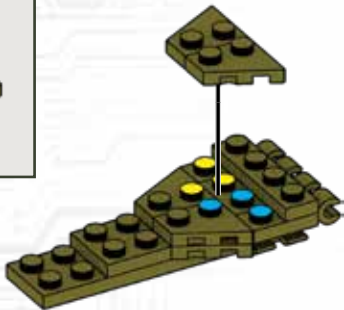

1

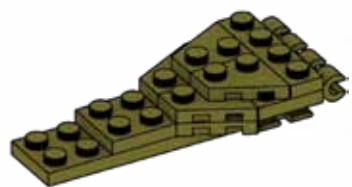

2



3

60



1X

2X

1X



Place temporary pieces. / Placer les pièces temporaires. / Colocar las piezas provisionales. / Colocar as peças temporárias. / Posizionare i pezzi provvisori. / Die vorübergehend benötigten Teile platzieren. / Umieść tymczasowe elementy. / Plaats tijdelijke delen. / Поместите временные детали. / Placér midlertidige stykker. / Placera temporära delar. / Plasser midlertidige deler. / Aseta väliaikaiset osat. / Τοποθετήστε το προσωρινό κομμάτι. / Geçici parçaları yerleştirin. / Umístěte dočasně díly. / Vložte dočasné kusy. / Helyezze el az ideiglenes darabokat. / 暫定ピースを配置してください.  
ضع القطع المؤقت.

放置临时件

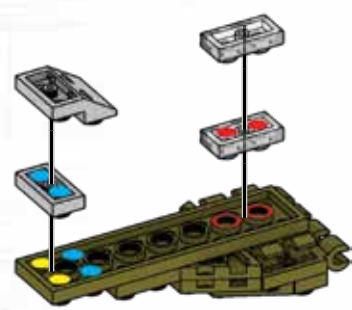

61

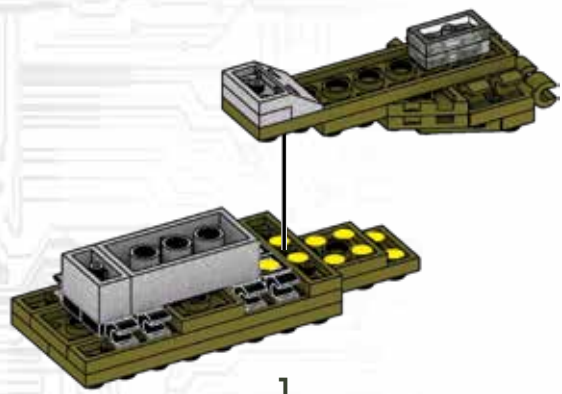

1

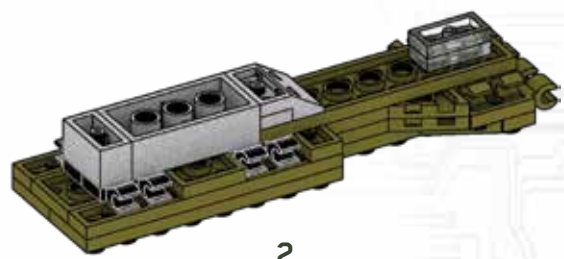

2

62



1X



1X



1X

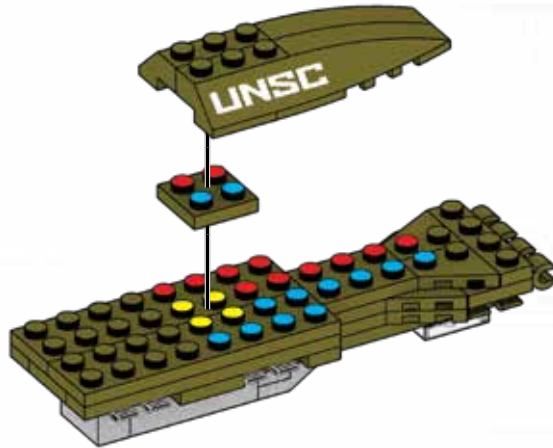

63



4X



64



4X



1X

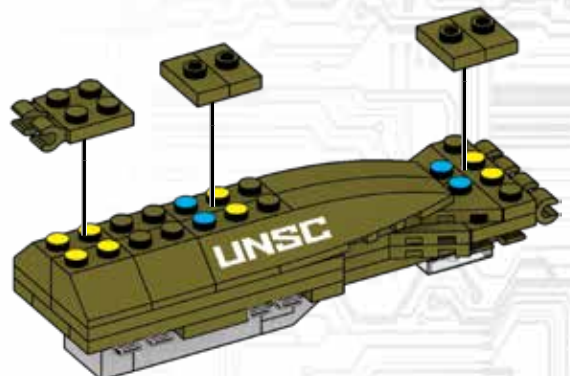

65



1X



1X



1X

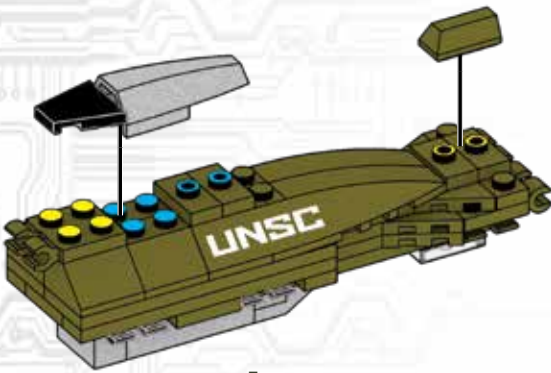

1

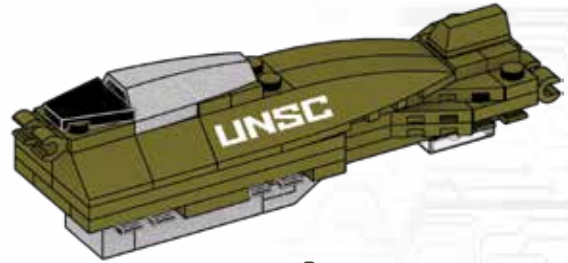

2

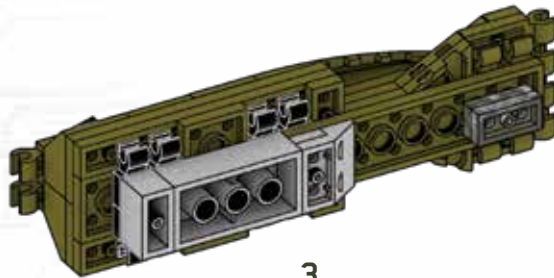

3

66



Remove temporary pieces. / Retirer les pièces temporaires. / Retirar las piezas provisionales.  
 Remover as peças temporárias. / Rimuovere i pezzi provvisori. / Die vorübergehend benötigten Teile entfernen  
 Usunać elementy tymczasowe. / Verwijder tijdelijke delen. / Удалите временные детали. / Fjern midlertidige stykker.  
 Ta bort temporära delar. / Fjern midlertidige deler. / Poista väliaikaiset osat. / Αφαιρέστε τα προσωρινά κομμάτια.  
 Geçici parçaları çıkarın. / Odstraňte dočasné diely. / Vyberte dočasné kusy. / Távolítsa el az ideiglenes darabokat.  
 暫定ピースを外してください

انزع القطع المؤقتة

移除临时件

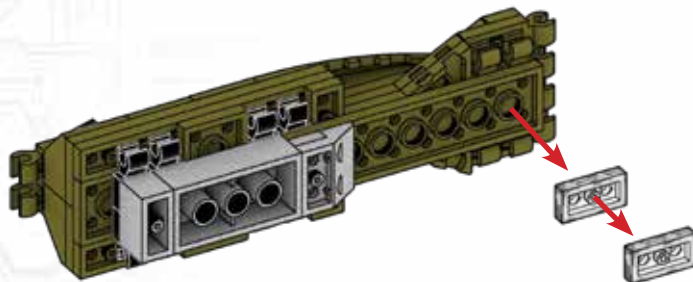

67

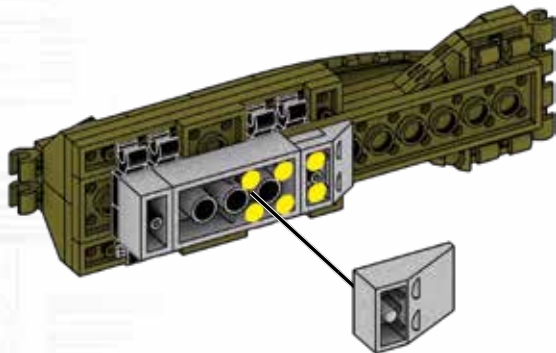

1

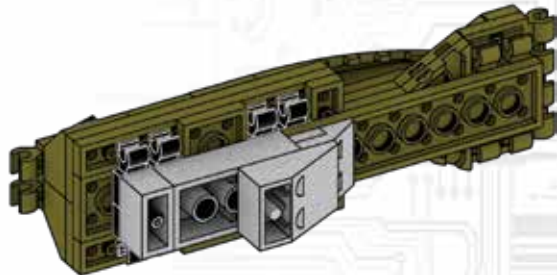

2

68



1X

1X

1X

1X

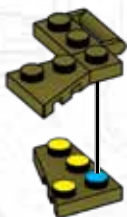

69



1X



1



2

70



1X

1X

1X

1X

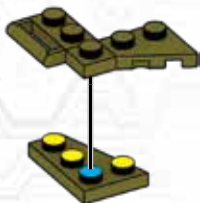

71



1X

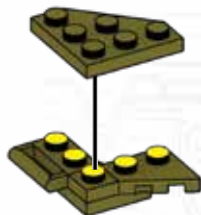

1



2

72

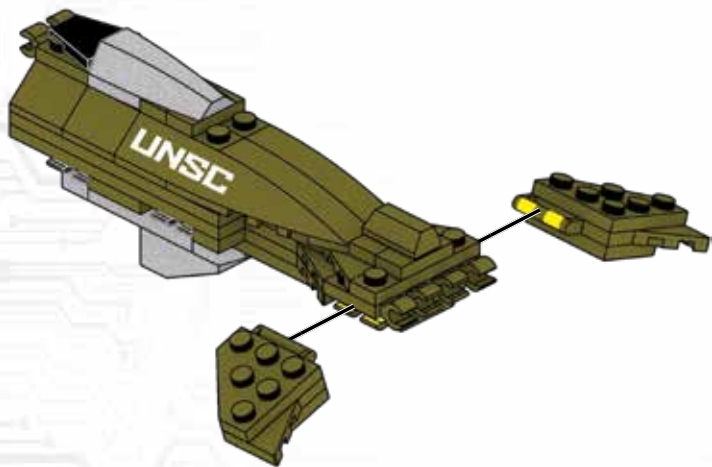

73

2X 2X 2X

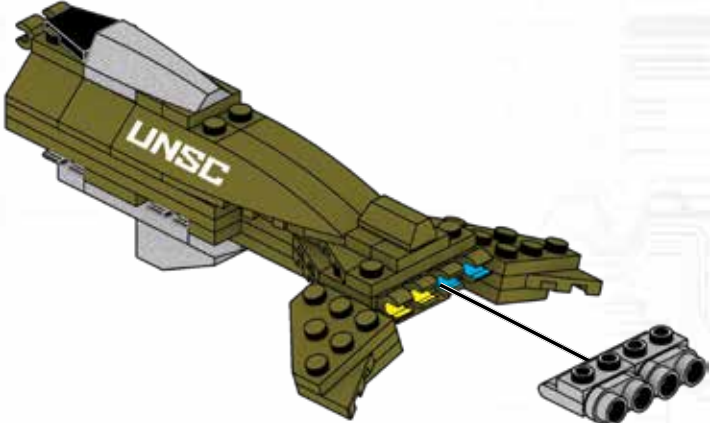
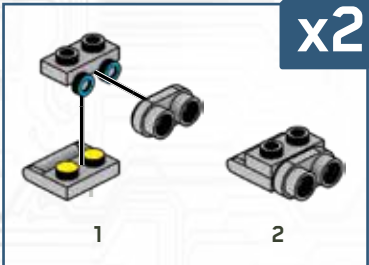

1

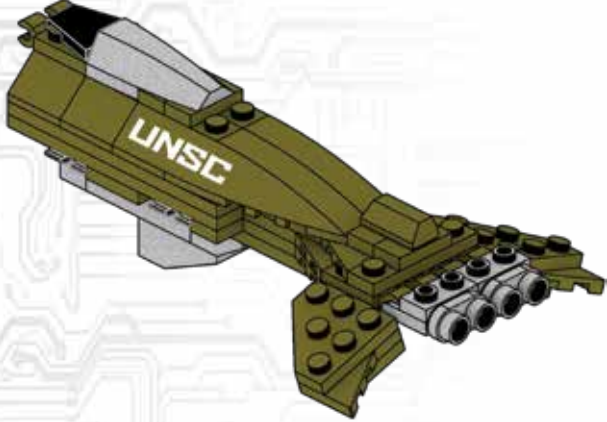

2



3

74

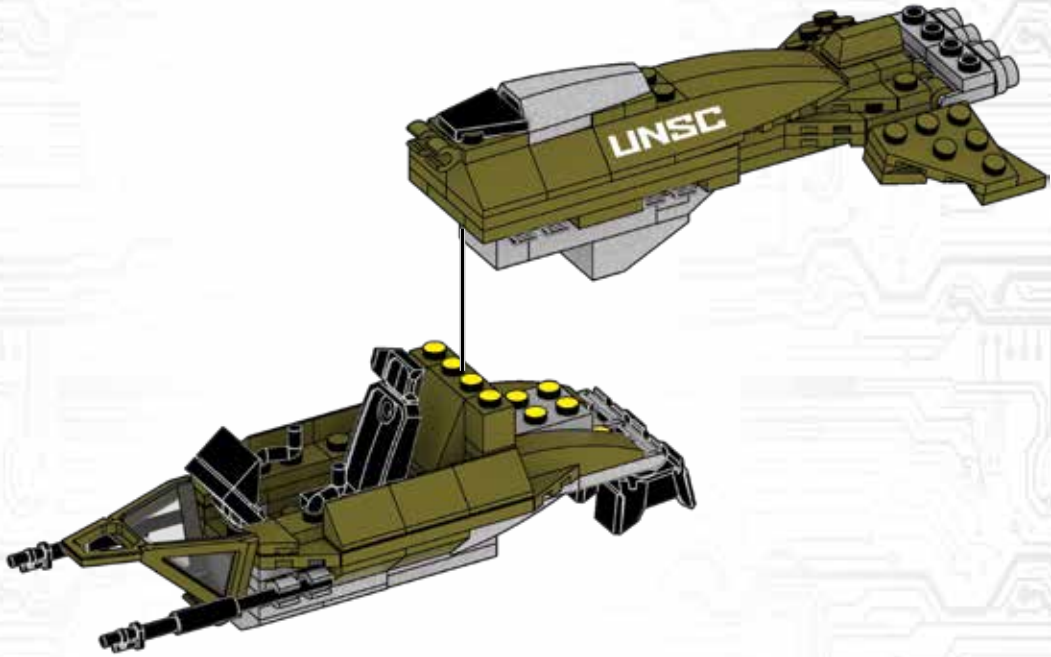

75

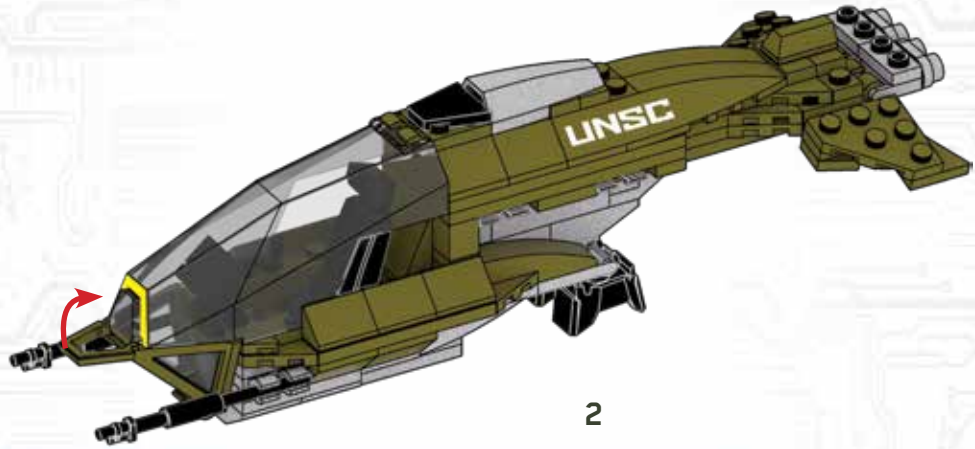
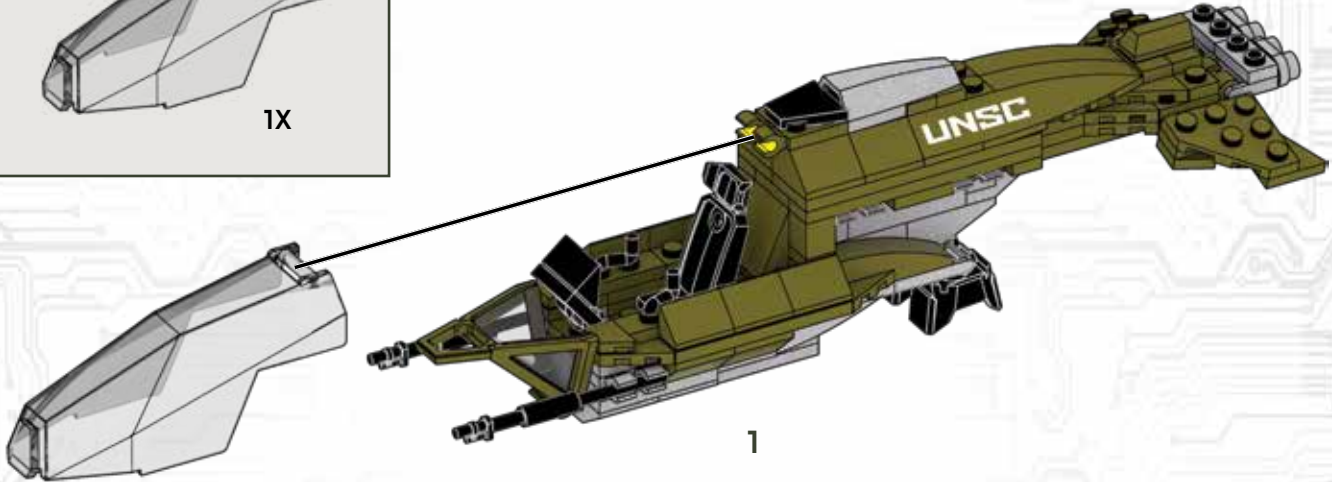
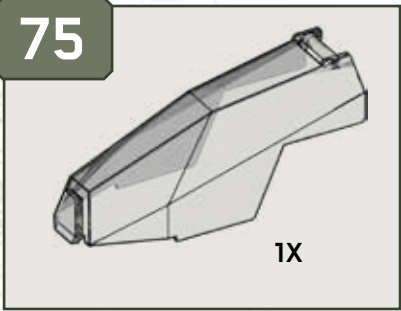

76



1X



1X

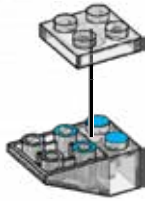

1

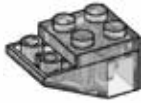

2

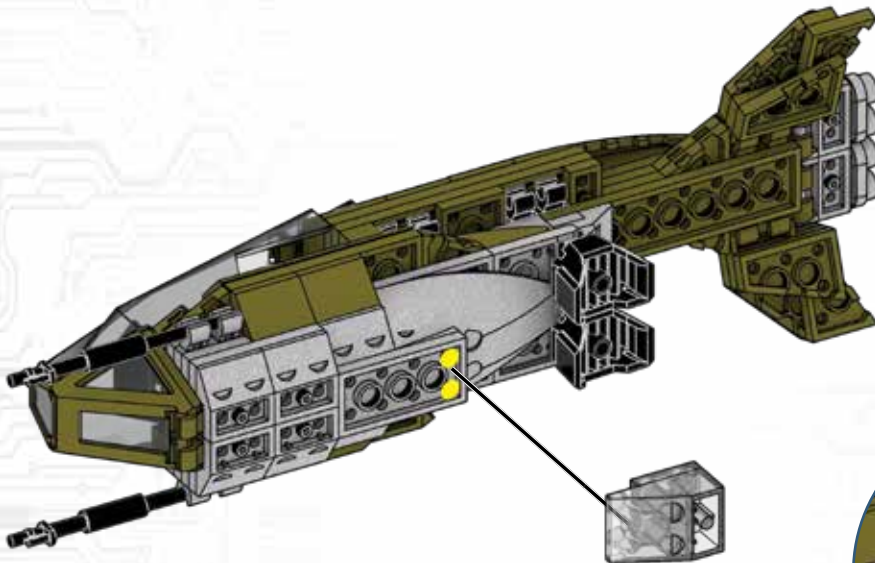

1

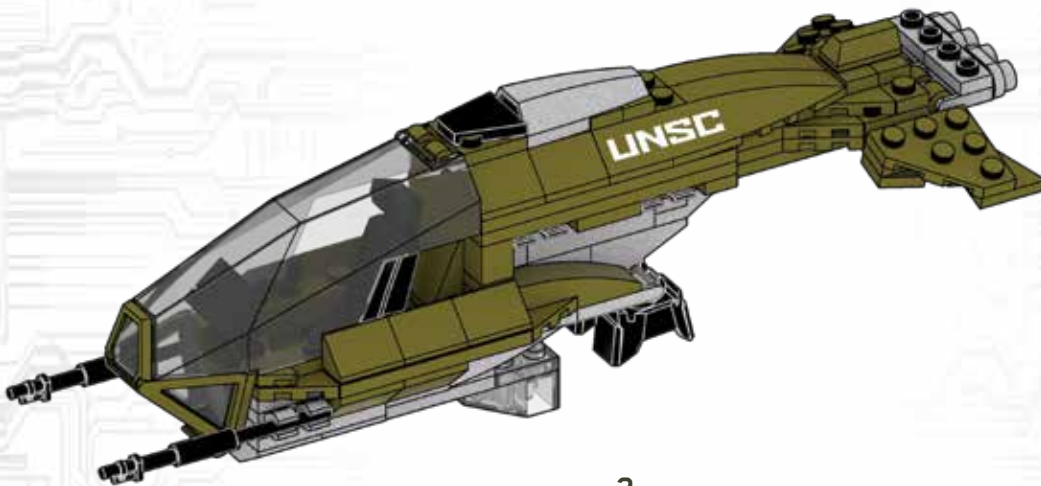
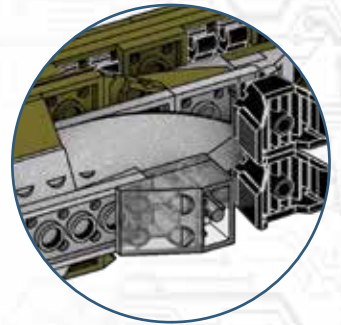

2

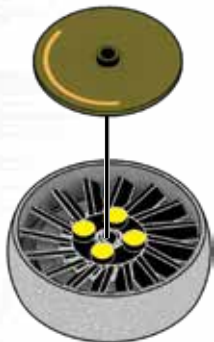
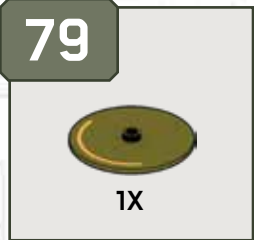
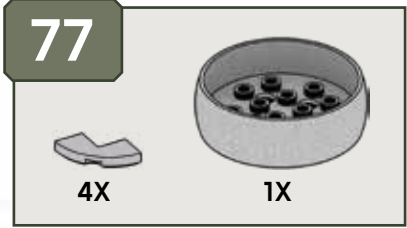

1



2



3



80



1X



1X

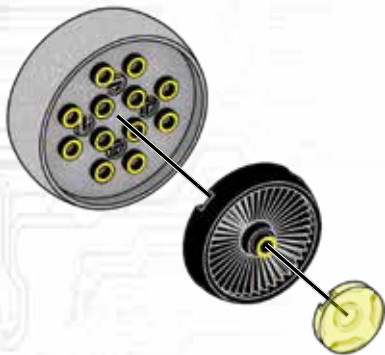

1



2

81



2X

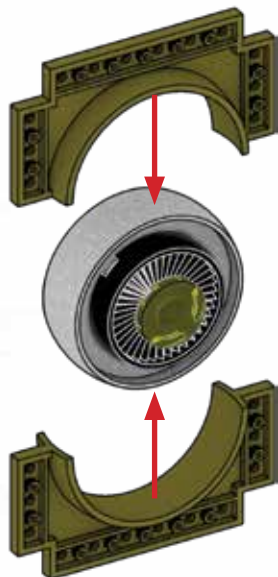

82



1X



1X

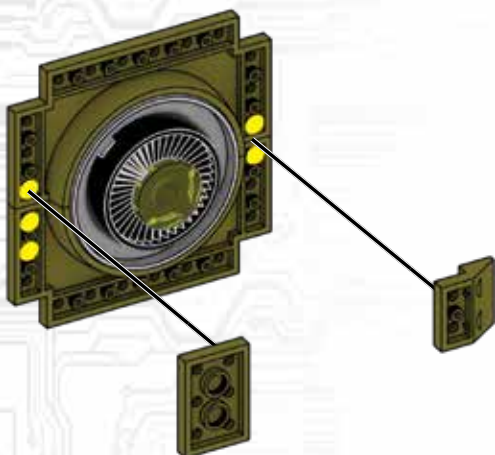

1

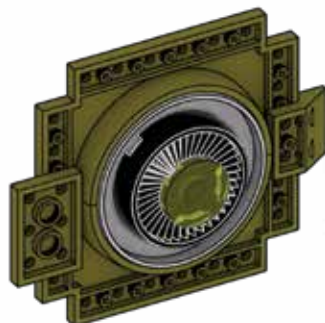

2



3

83



1X



1X

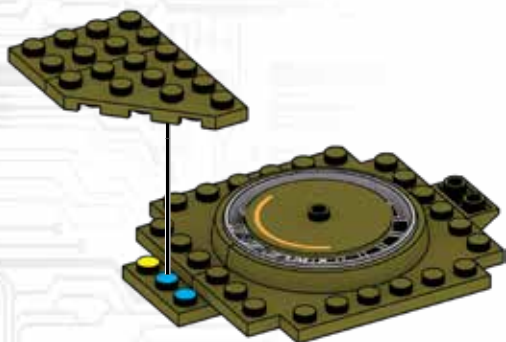

84



1X



1X

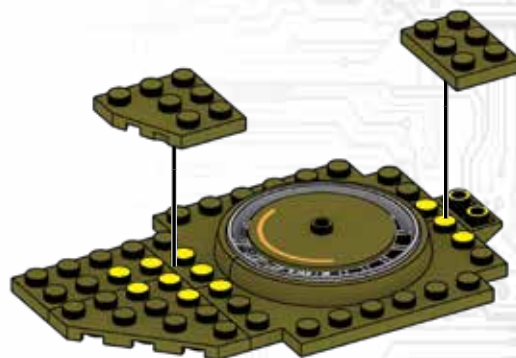

85

- 1X
- 2X

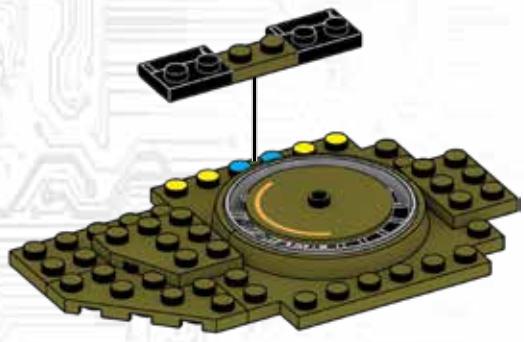

86

- 1X
- 1X



87

- 1X
- 1X
- 1X

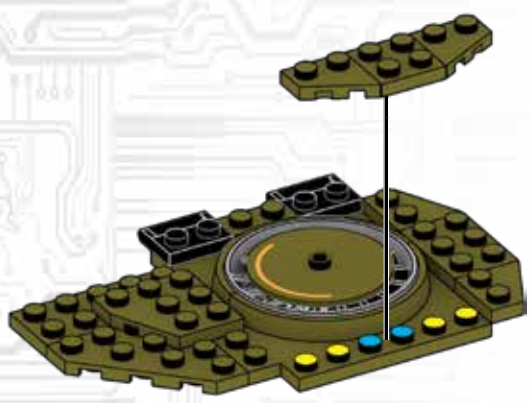

88

- 1X
- 1X
- 1X



89

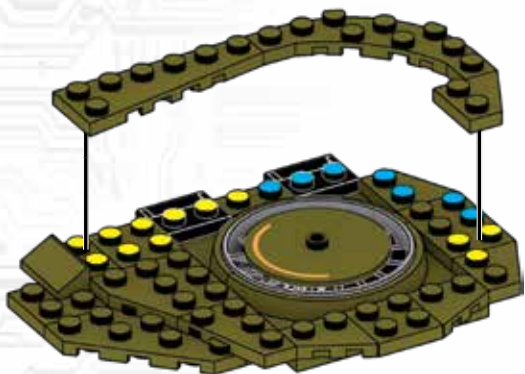
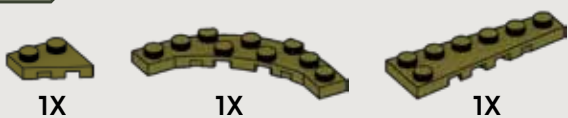

1

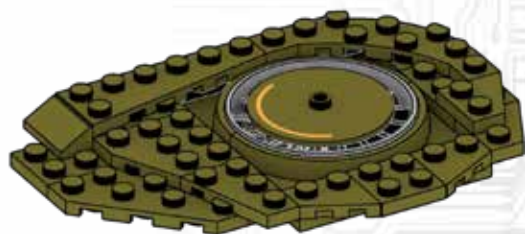

2

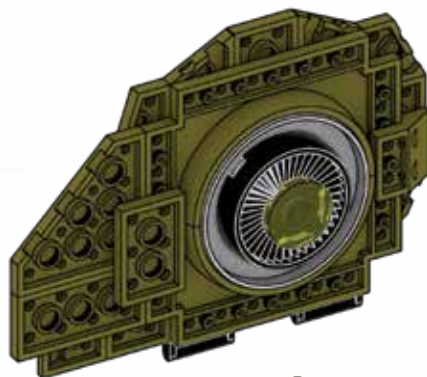

3

90

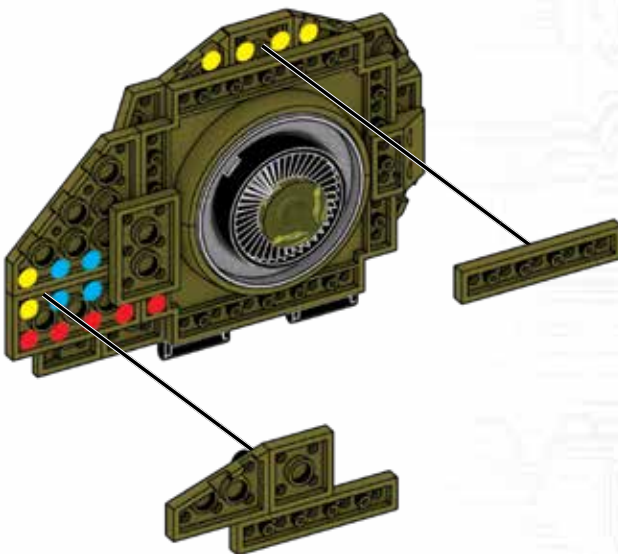
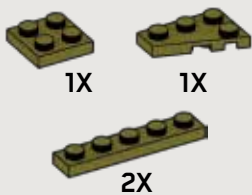

91



1X



2X

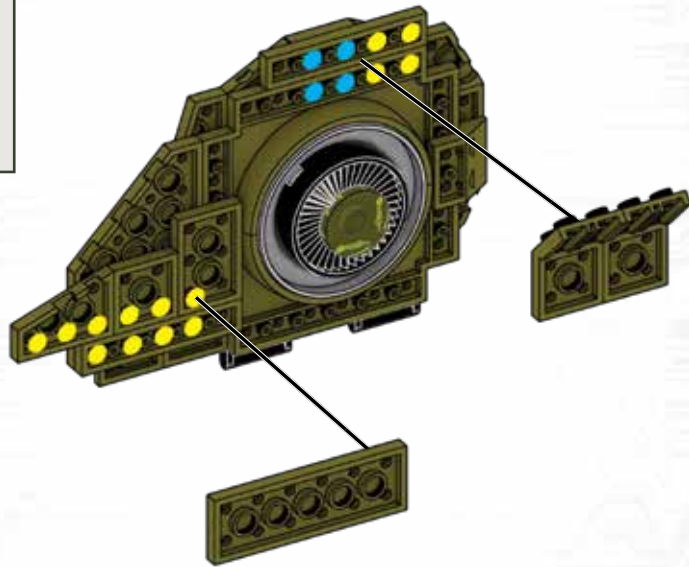

92



2X



1X

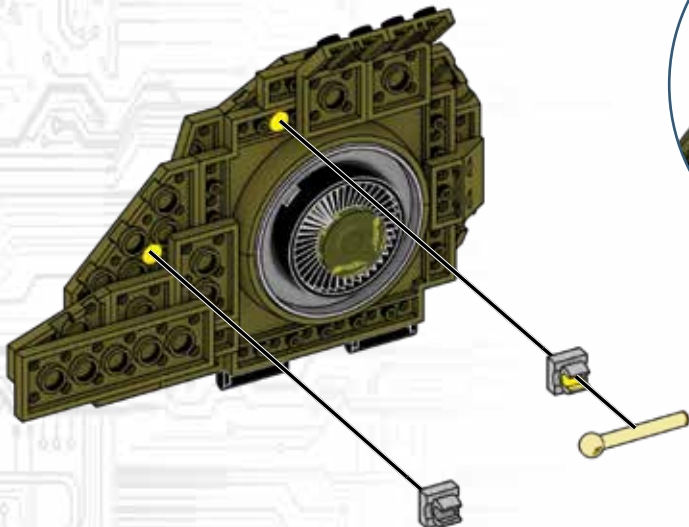

1

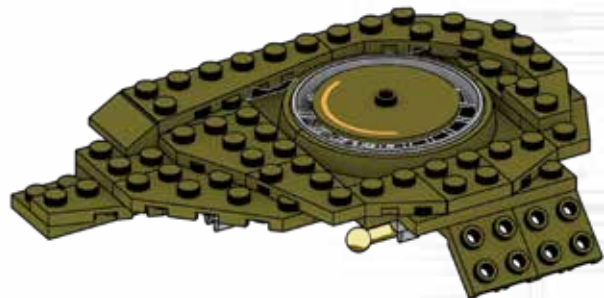
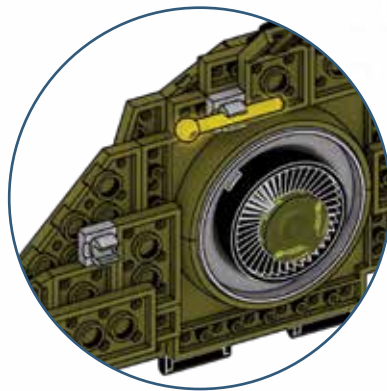

2

93



1X



1X



1X



1X

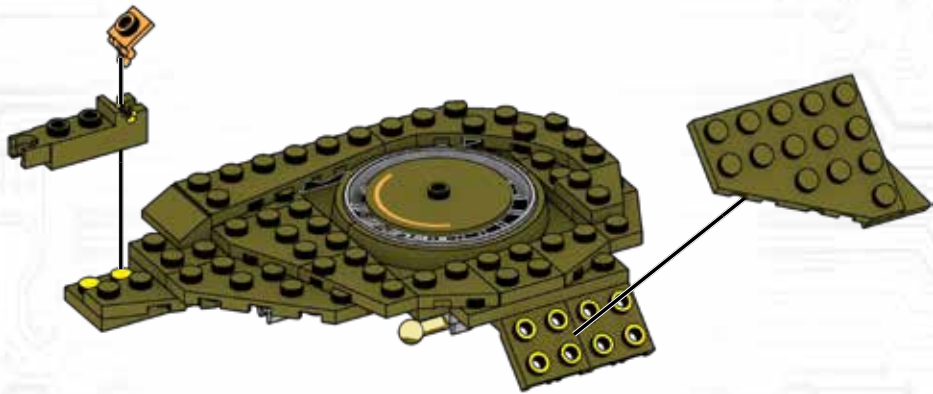
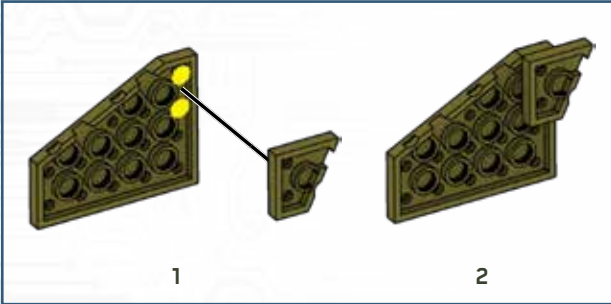

1

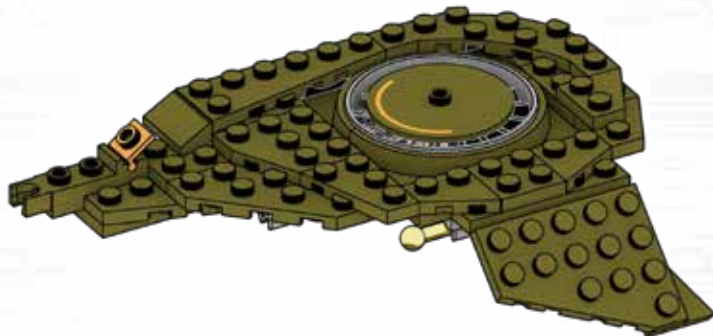

2

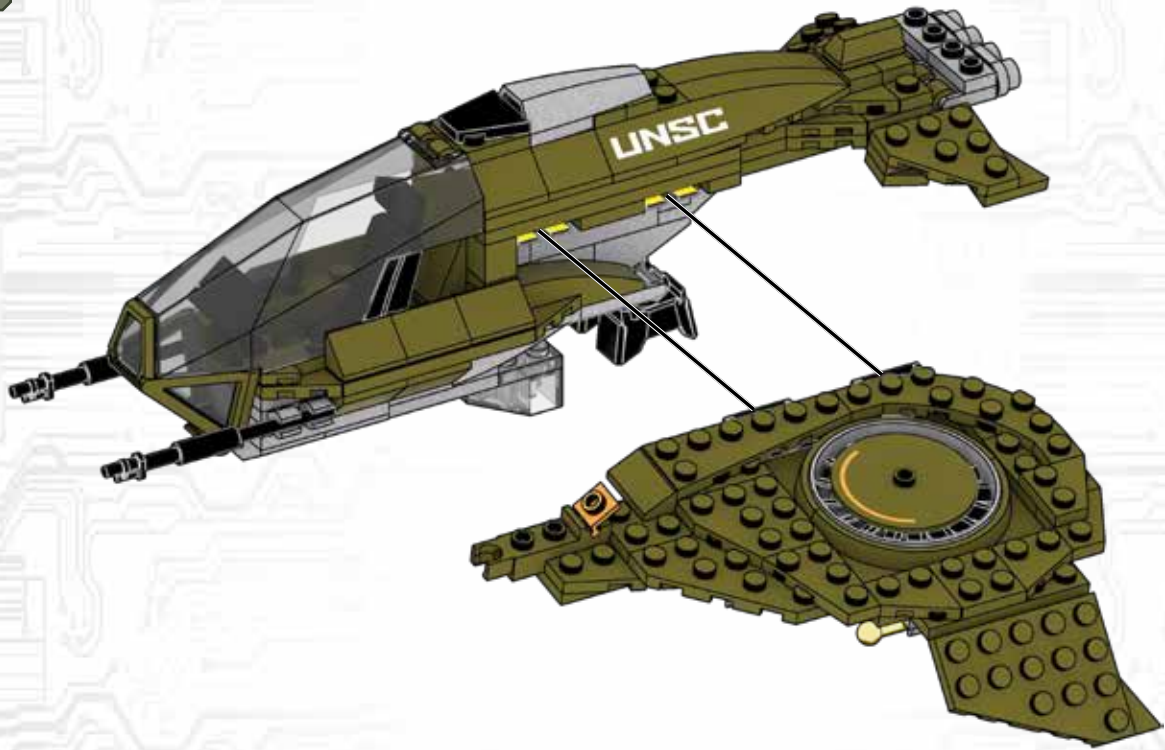

1

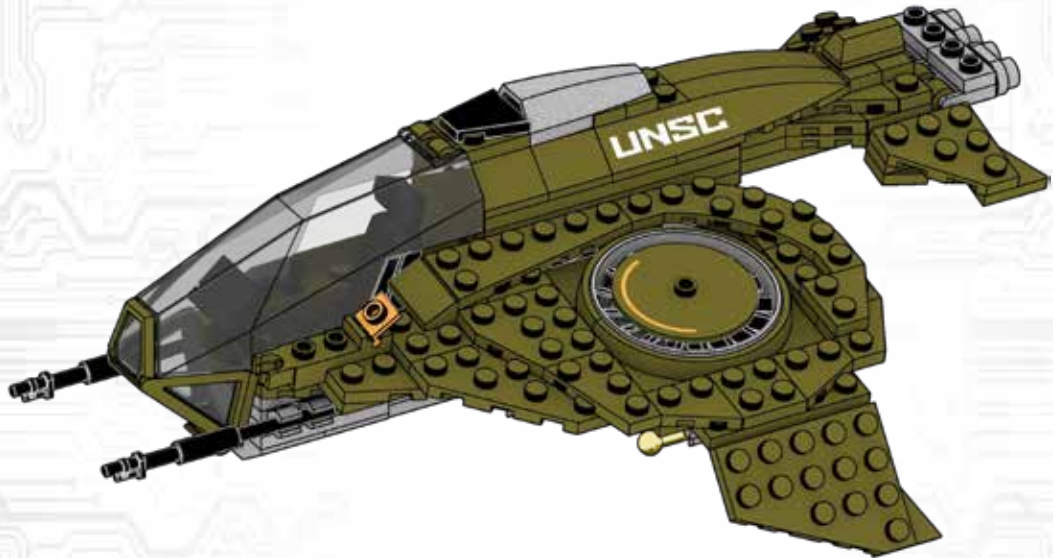

2

95



4X



1X

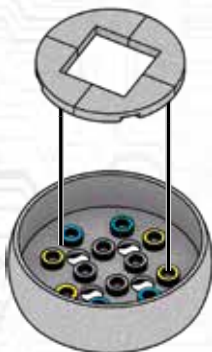

96



1X



1X



97



1X

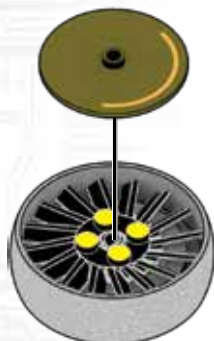

1

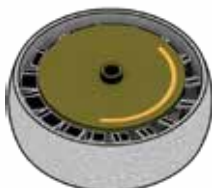

2



3



98



1X



1X

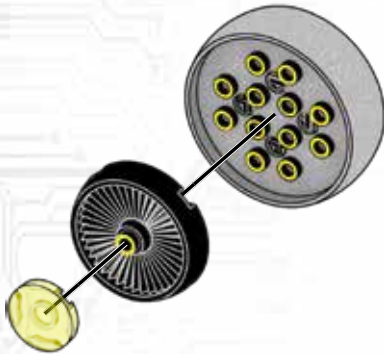

1



2

99



2X

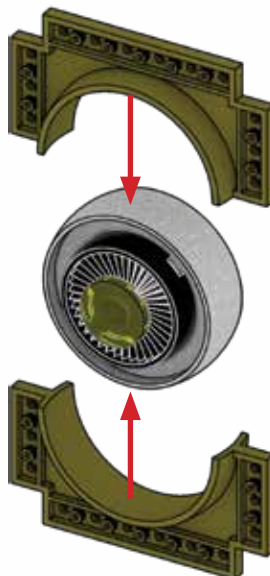

100

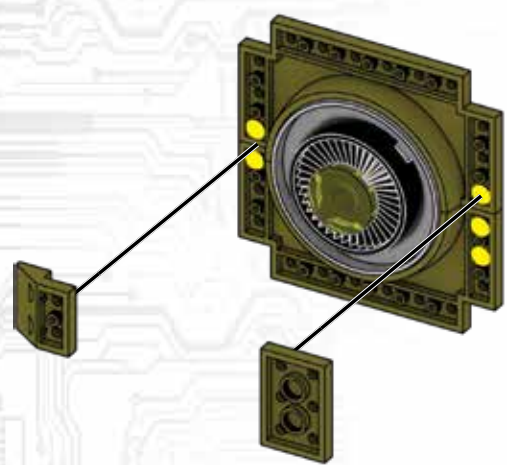

1



2



3

101

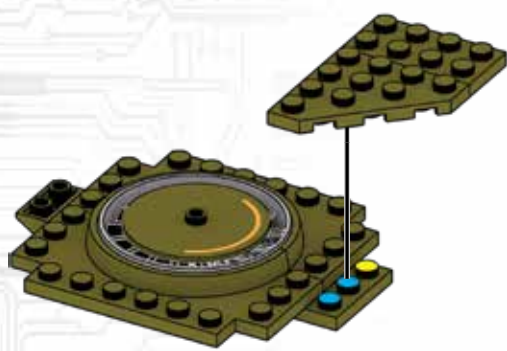

102

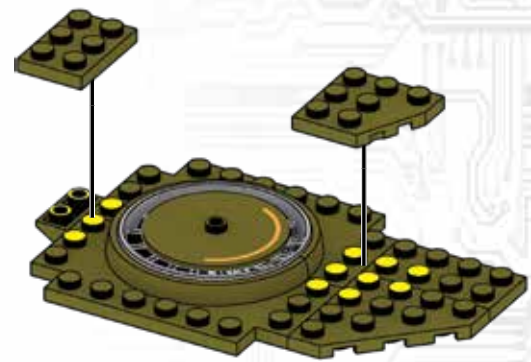

103



1X



2X

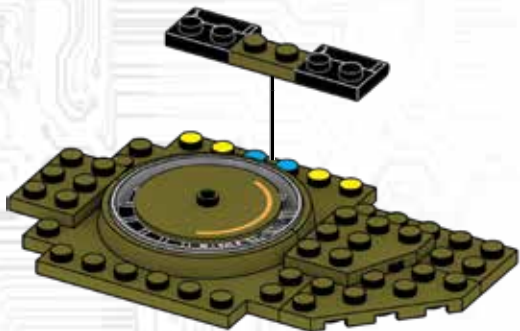

104



1X



1X



105



1X



1X



1X

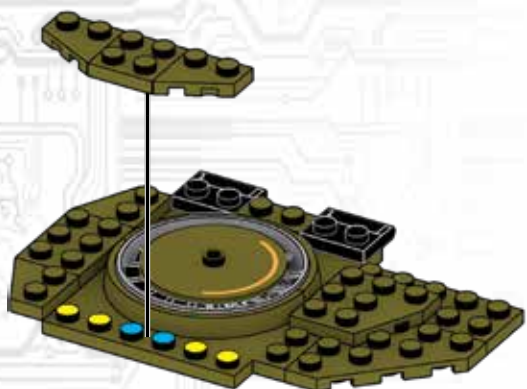

106



1X



1X



1X

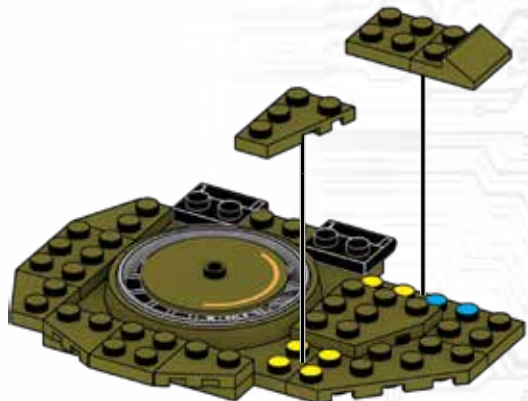

# 107

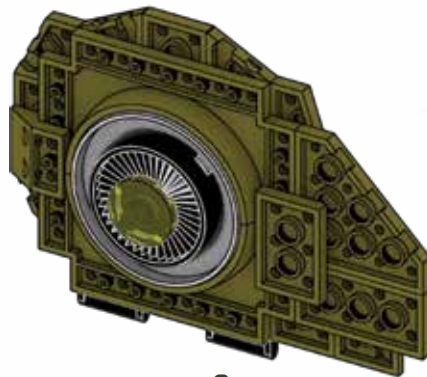
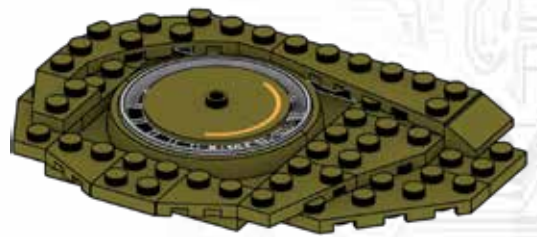
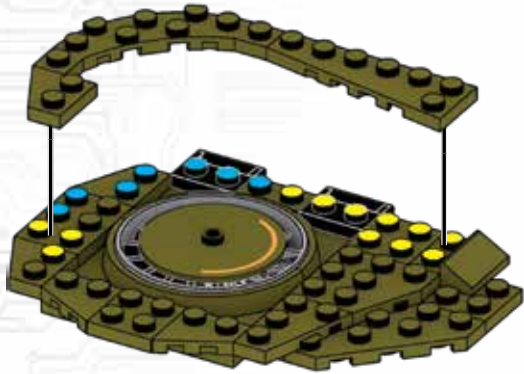

# 108

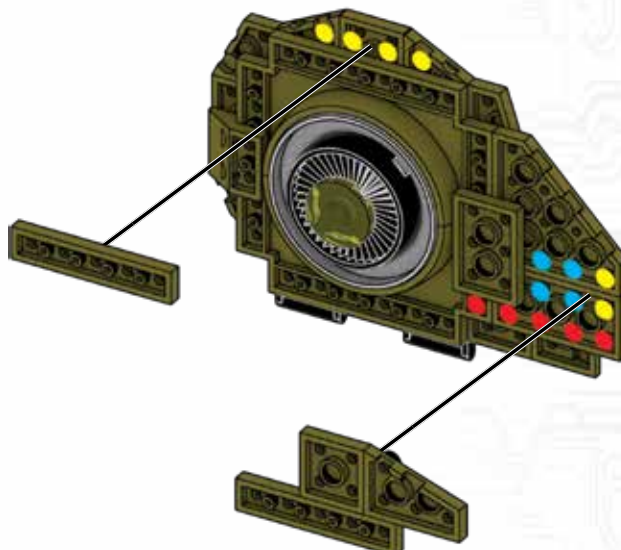
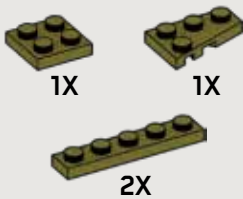

109



1X



2X

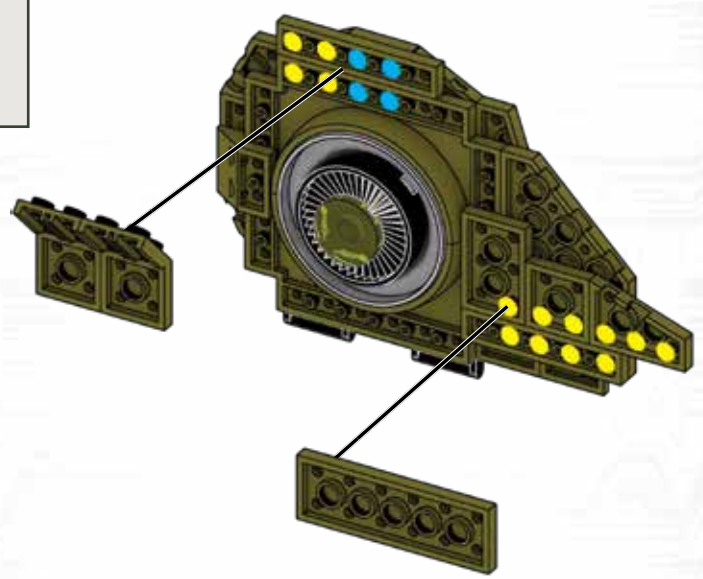

110



2X



1X

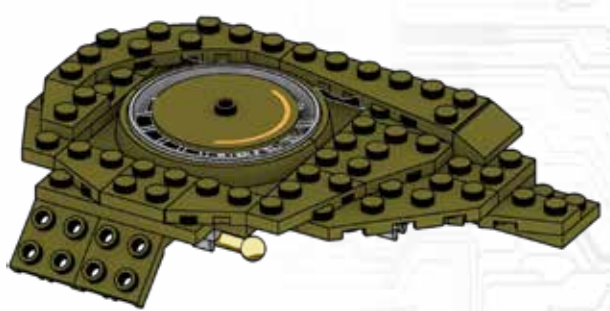
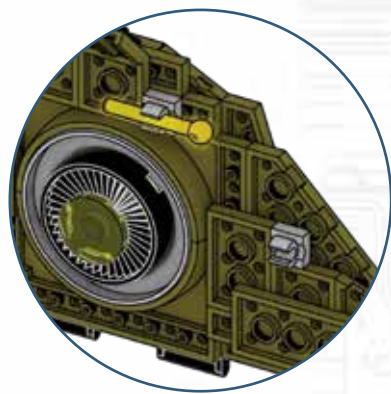
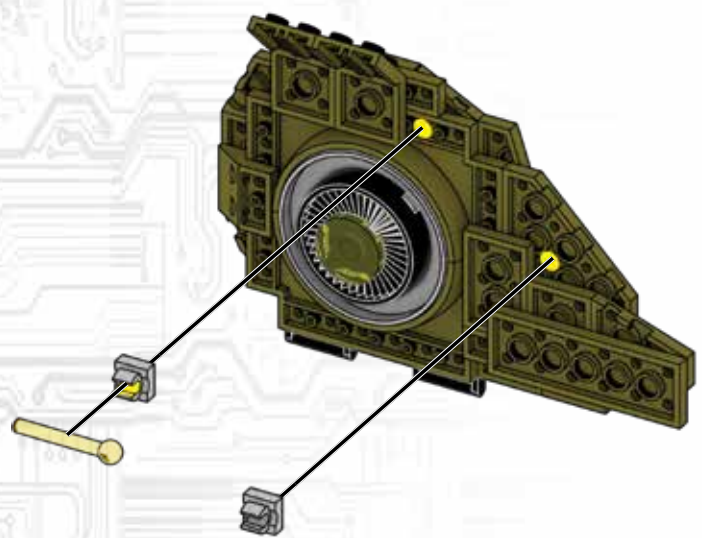

111



1X



1X

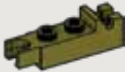

1X



1X

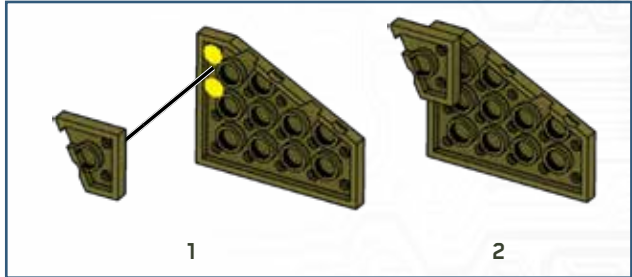

1

2

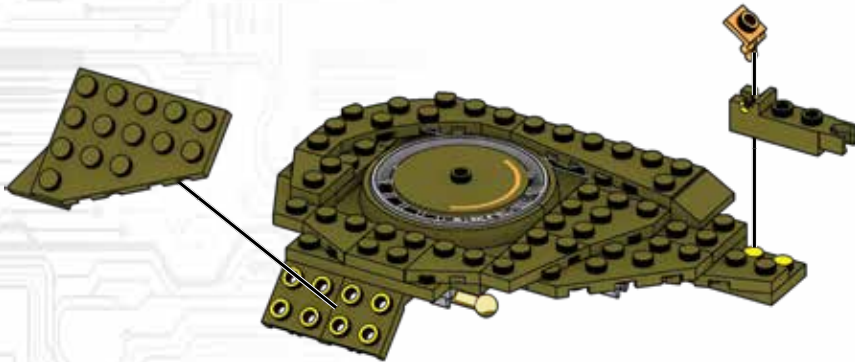

1

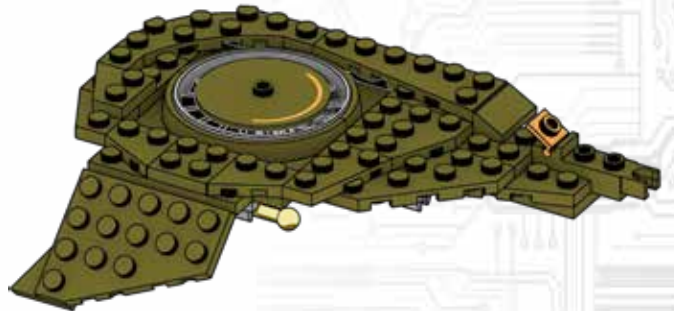

2

112



113



2X

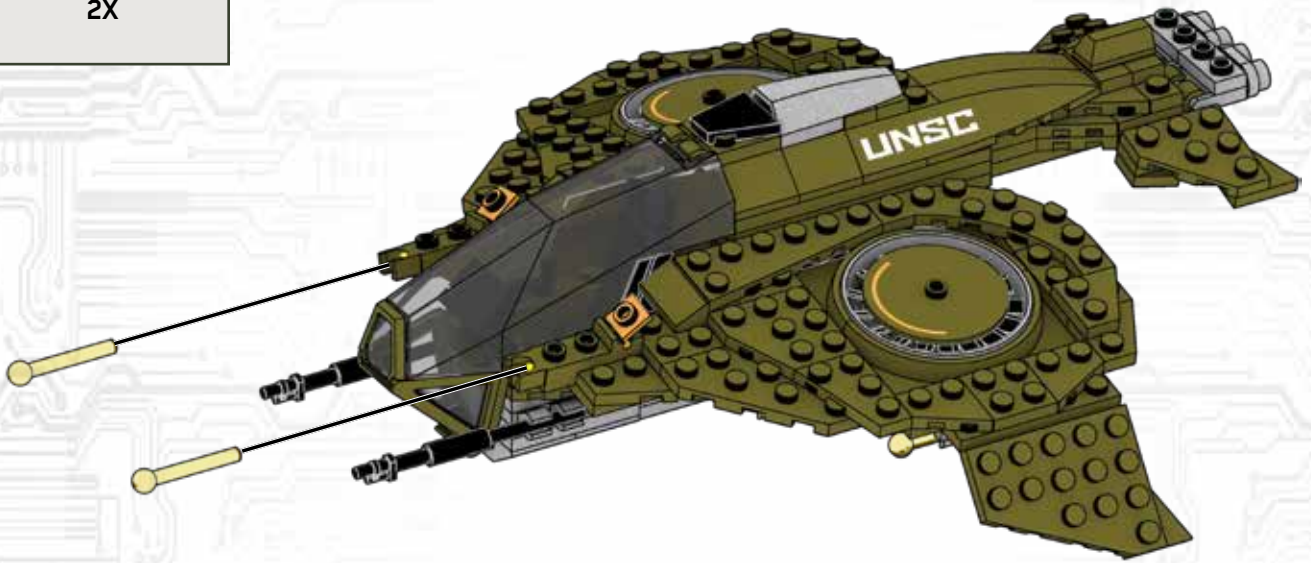

1



2

GRUNT CONSCRIPT

HUNTER

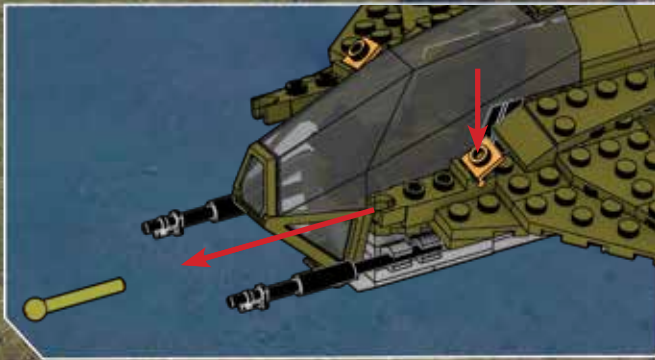

**⚠ WARNING: DO NOT AIM AT EYES OR FACE. ONLY USE PROJECTILES SUPPLIED WITH THIS TOY. DO NOT FIRE AT POINT BLANK RANGE. / ADVERTENCIA: NO APUNTAR A LOS OJOS NI A LA CARA. SI ADQUIRIÓ UN MODELO CON PROYECTIL(ES) INCLUIDO(S): UTILIZAR ÚNICAMENTE EL(LOS) PROYECTIL(ES) INCLUIDO(S) EN ESTE JUGUETE. NO DISPARAR A PERSONAS NI ANIMALES. NO DISPARAR A QUEMARROPA.**

**ATTENTION : NE PAS VISER LES YEUX OU LE VISAGE.**

**NE PAS UTILISER D'AUTRES PROJECTILES QUE CEUX FOURNIS AVEC CE JOUET.**

**NE PAS TIRER À BOUT PORTANT. / ATENÇÃO!: NÃO APONTAR PARA OS OLHOS E PARA A FACE. NÃO UTILIZAR PROJÉTEIS DIFERENTES DOS PROVIDOS E DOS INDICADOS PELO FABRICANTE DO BRINQUEDO. /**

**Avvertenza: Non mirare agli occhi o al viso. Usare solo i proiettili forniti con il giocattolo. Non sparare a distanza ravvicinata. / Achtung: Nicht auf Augen oder Gesicht zielen. Nur die zu diesem Spielzeug gehörenden Projektile verwenden. Nicht auf Menschen oder Tiere oder aus nächster Nähe zielen. / Ostrzeżenie: Nie celuj w oczy i twarz. Nie strzelaj pociskami innymi niż dostarczone z zabawką. Nie strzelaj z bliska. / Waarschuwing: niet op ogen of gezicht richten. Gebruik uitsluitend de bijgeleverde projectielen. Niet van te dichtbij afschieten. / Предупреждение: Не направляйте в глаза или лицо. Используйте только снаряды, входящие в комплект. Не стреляйте со слишком близкого расстояния. / Advarsel: Sigt ikke mod øjne eller ansigt. Brug kun de projektiler, som følger med legetøjet. Skyd ikke direkte på personer eller ting. / Varning: Sikta inte mot ögon eller ansikte. Använd endast projektiler som medföljer leksaken. Fyra inte av på mycket nära håll. / Advarsel: Du må ikke sikte mot øyne eller ansikt. Bruk bare prosjektilene som følger med leken. Ikke skyt på noe på kloss hold. / Varoitus: Älä tähtää silmiin äläkä kasvoihin. Käytä ainoastaan tämän tuotteen mukana tulleita ammuksia. Älä ammu lähietäisyydeltä. / Προσοχή: Μην στοχεύετε στα μάτια ή στο πρόσωπο. Χρησιμοποιείτε μόνο τα βλήματα που περιλαμβάνονται. Μην στοχεύετε όταν δεν έχετε ορατότητα. / Uyarı: Göze veya yüze nişan almayın. Fırlatmak için yalnızca bu oyuncakla birlikte verilen objeleri kullanın. İnsanlara ve hayvanlara nişan almayın.**

**Upozornění: Nemířte na oči nebo na obličej. Používejte pouze projektily dodávané s touto hračkou. Nestřílejte z bezprostřední blízkosti.**

**Figyelmeztetés: Tilos szemre és arcra célozni. Kizárólag a játékhoz mellékelte lövedékeket használja. A játékkal tilos közvetlen közelről löni.**

**警告: 目や顔に向けてのご使用、至近距離での発射はお控えください。このおもちゃの同梱物のみご使用ください。**

**تحذير: يجب عدم التصويب باتجاه العينين أو الوجه. يجب استخدام المقذوفات المزودة مع هذه اللعبة فقط. يجب عدم الإطلاق من مدى قريب.**

**警告: 请勿对着眼睛或脸部发射。仅使用本玩具自带的抛射物。请勿近距离射击。**



UNSC WASP ONSLAUGHT • ATTAQUE DU WASP DE L'UNSC  
EMBESTIDA DEL UNSC WASP • INVESTIDA DE WASP UNSC  
ASSALTO WASP UNSC | UNSC WASP ATTACKE | ATAK UNSC WASP | UNSC WESP AANVAL | ΗΑΤΙΣΚ UNSC WASP | UNSC ΕΠΕΛΑΣΗ | UNSC WASP SALDIRISI  
UNSC WASP TÁMADÁS | UNSC WASP-ATTACK | UNSC WASP – ANGREB



MASTER CHIEF

UNSC MARINE



SPINNING ENGINES  
RÉACTEURS ROTATIFS

MOTORES GIRATORIOS • MOTORES GIRATÓRIOS  
SICH DREHENDE ANTRIEBE • Кружащие паровозы

- 6x  AM0113AAV
- 2x  AM78600FM
- 4x  AM03328AXU
- 2x  AM03328AKM
- 4x  AM18623APG
- 2x  AM01086AXU
- 2x  AM01140AKM
- 2x  AM19328AWC
- 8x  AM74415F
- 6x  AM74415AXU
- 1x  AM74299AXU
- 1x  AM74300AXU
- 3x  AM18260F
- 2x  AM18260AWC
- 2x  AM17506F
- 2x  AM73904F
- 2x  AM19327APG
- 1x  AM78866AXU
- 1x  AM72331AKM

- 4x  AM022501AAV
- 5x  AM07590AXU
- 3x  AM09393APG
- 4x  AM09393AXU
- 2x  AM09393AKM
- 2x  AM09393W
- 2x  AM76467APG
- 1x  AM79070AKM
- 1x  AM76467AKM
- 2x  AM16649APG
- 4x  AM18740AWC
- 1x  AM18232AXU
- 12x  AM18665AXU
- 12x  AM18666AXU
- 2x  AM02215AMZ
- 2x  AM78486AKM
- 6x  AM03019AXU
- 1x  AS-GYG60-03



- 8x  AM18667APG
- 2x  AM72000APG
- 2x  AM72000AXU
- 5x  AM72000F
- 2x  AM81262F
- 1x  AM76456F
- 2x  AM76456AWC
- 1x  AM03484GD
- 1x  AM03485GD
- 1x  AM03773W
- 10x  AM03773AXU
- 2x  AM03773AWC
- 1x  AM09268F
- 2x  AM0948AWC
- 1x  AM18525AWC
- 1x  AM09013APG
- 1x  AM09013AWC

- 2x  AM76354F
- 4x  AM78601ZD
- 7x  AM18223APG
- 2x  AM18223AXU
- 2x  AM78189AXU
- 1x  AM74106AKM
- 4x  AM01154AXU
- 4x  AM10273AXU
- 1x  AM72330AKM
- 1x  AM15488AKM
- 1x  AM18562AXU
- 1x  AM17049F
- 2x  AM76663F

- 2x  AM16975AXU
- 2x  AM74298AXU
- 4x  AM16653AXU
- 2x  AM18328AXU
- 2x  AM18328APG
- 2x  AM18329APG
- 2x  AM18329AWC
- 3x  AM17073AXU
- 2x  AM17073AKM
- 3x  AM17074AXU
- 2x  AM17074AKM
- 2x  AM03772AKM
- 6x  AM03772AXU
- 1x  AM01139APG
- 1x  AM01139W

- 2x  AM76521F
- 2x  AM19323AXU
- 2x  AS-GYG60-05
- 2x  AM16640F
- 2x  AM18279AXU
- 1x  AM18282AXU
- 1x  AM18283AXU
- 5x  AM09593AXU
- 2x  AM09593AWC
- 3x  AM09593AKM
- 1x  AM08416APG

- 2x  AM74416AKM
- 1x  AM18299AWC
- 3x  AM09493AXU
- 6x  AM09493APG
- 2x  AM09033APG
- 1x  AM76367AAV
- 2x  AM78599AXU
- 4x  AM07475AXU
- 4x  AM76357ALG

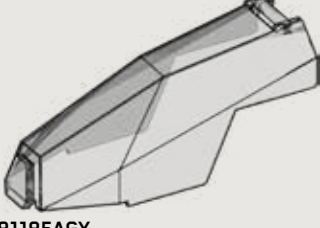
- 1x  AM81290AJD
- 2x  AM81291AJD
- 1x  AM81185AGY

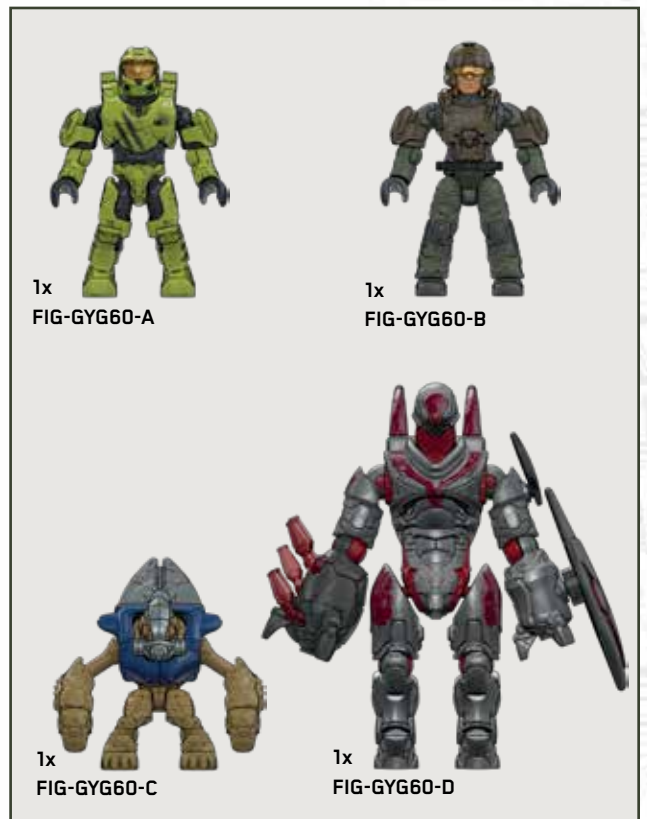
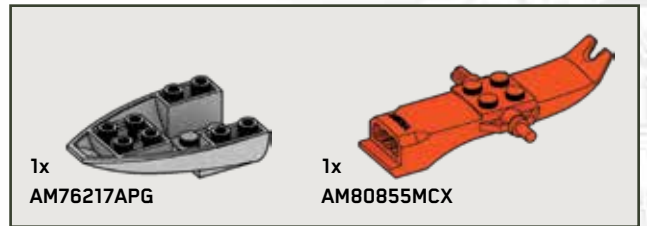
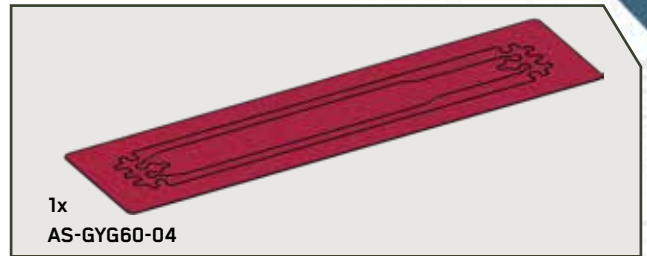
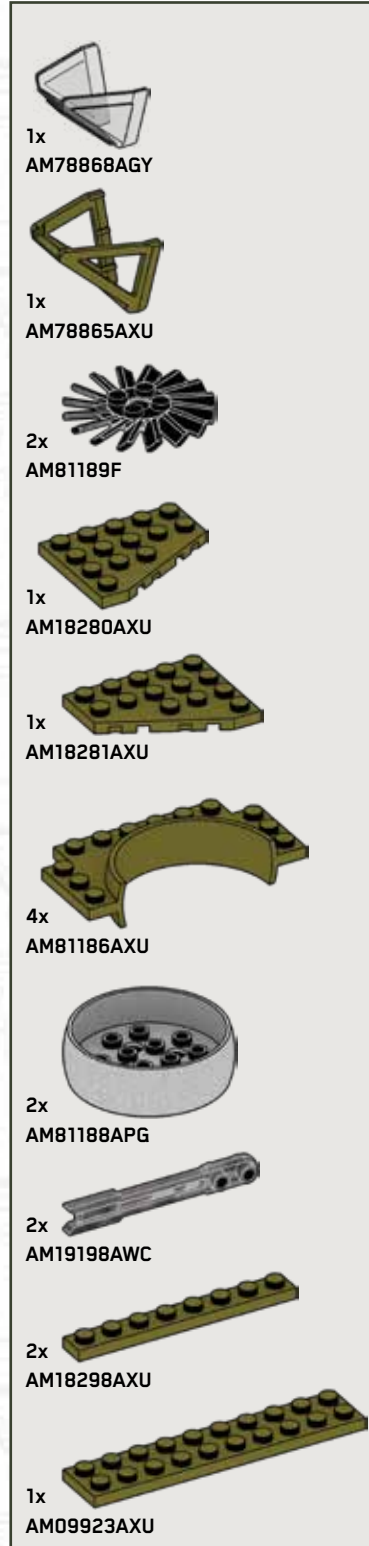
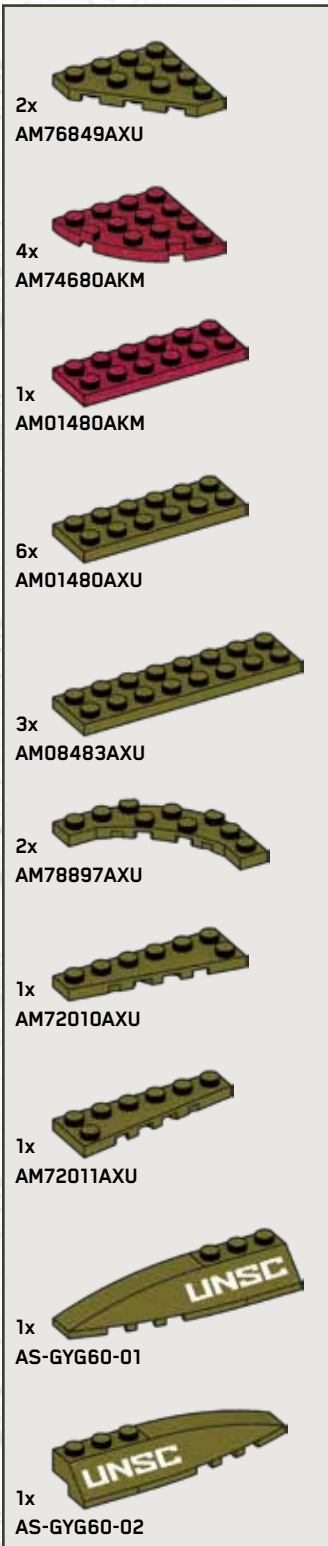

Instructions included for main model only. Other build(s) can be found at [megaunboxed.com](http://megaunboxed.com) / Instructions incluses pour le modèle principal uniquement. Les instructions pour l'(les) autre(s) modèle(s) de construction se trouvent sur le site [megaunboxed.com](http://megaunboxed.com) / Nur für das Hauptmodell ist eine Anleitung enthalten. Unter [megaunboxed.com](http://megaunboxed.com) finden Sie weitere Bauanleitungen. / Istruzioni incluse solo per il modello principale. È possibile trovare le altre costruzioni su [megaunboxed.com](http://megaunboxed.com) / Instructies alleen bij het hoofdmodel. Andere bouw mogelijkheden kunt u vinden op [megaunboxed.com](http://megaunboxed.com) / Se incluyen las instrucciones para el modelo principal solamente. Se pueden encontrar otras construcciones en [megaunboxed.com](http://megaunboxed.com) / Instruções incluídas somente para o modelo principal. Outras montagens podem ser encontradas em [megaunboxed.com](http://megaunboxed.com) / Instruktioner medföljer endast för huvudmodellen. Andra byggen finns på [megaunboxed.com](http://megaunboxed.com) / Ohjeet ovat sisällytetyjä vain päämalleihin. Muut kokoonpanot ovat löydettävissä osoitteessa [megaunboxed.com](http://megaunboxed.com) / Vejledningen følger kun med hovedmodellen. Andre byggemodeller kan findes på [megaunboxed.com](http://megaunboxed.com) / Instruksjoner kun inkludert for hovedmodell. Annen/andre versjon/-er finner du på [megaunboxed.com](http://megaunboxed.com) / Załączono instrukcje tylko do głównego modelu. Inne wersje są dostępne na [megaunboxed.com](http://megaunboxed.com) / Přibalené pokyny jsou pouze pro hlavní model. Ostatní stavby lze najít na [megaunboxed.com](http://megaunboxed.com) / Přibalené pokyny sú iba hlavný model. Ostatné stavby možno nájsť na [megaunboxed.com](http://megaunboxed.com) / A mellékelt utasítások csak a fő modellre vonatkoznak. Egyéb építőelem(ek) a [megaunboxed.com](http://megaunboxed.com) weboldalon található(k) / Инструкция относится только к основной модели. Другие конструкции можно найти на сайте [megaunboxed.com](http://megaunboxed.com) / Οι οδηγίες που περιλαμβάνονται είναι μόνο για το κύριο μοντέλο. Μπορείτε να βρείτε άλλες κατασκευές στο [megaunboxed.com](http://megaunboxed.com) / Yönergeler sadece ana modeller için dahil edilmiştir. Diğer yapı parçaları [megaunboxed.com](http://megaunboxed.com) adresinde bulunabilir / メインのモデルのみの取扱説明書が含まれています。他のは[megaunboxed.com](http://megaunboxed.com)にあります。 / التعليمات موجودة للنموذج الرئيسي فقط. يمكن العثور على بناء (أخرى) على موقع [megaconstrux.com](http://megaconstrux.com) / 拼搭指南仅包含主体部分的拼搭指导。其他部分拼搭指导可以上 [megaunboxed.com](http://megaunboxed.com) 查找



# HALO

**MORE TO COLLECT!  
ENCORE PLUS  
À COLLECTIONNER!  
MÁS PARA  
COLECCIONAR!**

**MAIS PARA  
COLECCIONAR!  
MEHR ZUM  
SAMMELN!  
СОБЕРИ БОЛЬШЕ!**



GYG57



GYG58

Set(s) sold separately and subject to availability. / Ensemble(s) vendu(s) séparément. Certains produits peuvent ne pas être commercialisés. / Se vende(n) por separado y está(n) sujeto(s) a disponibilidad. / Conjunto(s) vendido(s) em separado e sujeito(s) à disponibilidade. / Set in vendita separatamente, secondo disponibilità. / Das/Die Set(s) sind separat erhältlich. / Zestaw(y) sprzedawany(eg) oddzielnie w zależności od dostępności. / Set(s) apart verkrijgbaar en afhankelijk van beschikbaarheid. / Набор(-ы) продаются отдельно, при наличии. / Set sælges separat og så længe lager haves. / Seten säljs separat så länge lagret räcker. / Settet/settene selges separat så langt lageret rekker. / Pakkaus/pakkaukset myydään erikseen, saatavuus voi vaihdella. / Το(α) σετ πωλούνται ξεχωριστά και ανάλογα με τη διαθεσιμότητα. / Setler ayrı olarak satılır ve stoklarla sınırlıdır. / Set (sety) se prodává (prodávají) samostatně dle aktuální nabídky. / Súprava/-y sa predáva(jú) samostatne a podľa dostupnosti. / A készlet(ek) külön kapható(k), az elérhetőség változhat. / セット商品は別売りになります。在庫状況は別途ご確認をお願いします。 /

تباع المجموعة أو المجموعات على حدة وتخضع لتوافرها  
每套单独发售，按供货情况决定。



Mattel Europa B.V., Gondel 1, 1186 MJ Amstelveen, Nederland. Mattel U.K. Limited, The Porter Building, 1 Brunel Way, Slough SL1 1FQ, UK. Mattel France, Parc de la Cerisaie, 1/3/5 allée des Fleurs, 94260 Fresnes Cedex. N° Cristal 0969 36 99 99 (Numéro non surtaxé) ou www.lesjouetsmattel.fr Mattel Belgium, Trade Mart, Atomiumsquare, Bogota 202 - B 275, 1020 Brussels. Gratis nummer België: 0800 - 16 936 - Gratis nummer Luxemburg: 800 - 22 784 - Gratis nummer Nederland: 0800 - 262 88 35. Deutschland: Mattel GmbH, Solmsstraße 83, D-60486 Frankfurt am Main. Schweiz: Mattel AG, Kirchstrasse 24, CH-3097 Liebefeld. Österreich: Mattel Ges.m.b.H., Campus 21, Liebermannstraße A01 404, A- 2345 Brunn/Gebirge. Mattel Italy Srl, Via Turati 4, 20121 Milano, Italy. Servizio assistenza clienti: Customerservizi@mattel.com - Numero verde 800 11 37 11. Mattel España, S.A. Aribau 200 pl. 9, 08036 Barcelona. cservice.spain@mattel.com Tel: +34 933 06 79 00 http://www.service.mattel.com/es. Mattel East Asia Ltd., Room 503-09, North Tower, World Finance Centre, Harbour City, Tsimshatsui, HK, China. Tel: (852) 3185-6500. Diimport & Diedarkan Oleh: Mattel Continental Asia Sdn Bhd, Level 19, Tower 3, Avenue 7, No. 8, Jalan Kerinchi, Bangsar South, 59200 Kuala Lumpur, Malaysia. Mattel South Africa (PTY) LTD, Office 102 B, 30 Melrose Boulevard, Johannesburg 2196. Dystrybutor: Mattel Poland Sp. z o.o., Warsaw Trade Tower 34 p., ul. Chłodna 51, 00-867 Warszawa. Mattel Australia Pty Ltd., 658 Church St., Richmond, Victoria, 3121. Consumer Advisory Service - 1300 135 312. Mattel AEBE, Εθνάρχου Μακαρίου 1, Κτηγόριο Κ-2, ΤΚ 17561, Πολιόιο Φόληρο. Mattel Ouncuncakçılık Tic. Ltd. Şti. İçerenköy Mah., Umut Sok. No:10-12 Quick Tower Kat:2/15 34752 Ataşehir İstanbul Tel:0216 570 75 00. Импортер/Уполномоченная организация: ООО "МАТТЕЛ" Российская Федерация, 105120 Москва, 2-й Сыромятинский переулок, 1; +7 495 287 79 39. Mattel Czech Republic s.r.o., The Forum, Václavské nám. 19, 11000 Praha1. Mattel, 333 Continental Boulevard, El Segundo, CA 90245, USA. Consumer Services: 1-800-465-MEGA (6342). Mattel Canada Inc., Mississauga, Ontario L5R 3W2. Consumer Services: You may call us free at/ Composez sans frais le 1-800-524-8697. Importado y distribuido por Mattel de México, S.A. de C.V., Miguel de Cervantes Saavedra No. 193, Pisos 10 y 11, Col. Granada, Alcaldía Miguel Hidalgo, C.P. 11520, México, Ciudad de México. R.F.C. MME-920701-NB3. Tels.: 59-05-51-00 Ext. 5206 ó 01-800-463-59-89. Mattel Chile, S.A., Avenida Américo Vespucio 501-B, Quilicura, Santiago. Tel.: 1230-020-6213. Servicio al consumidor Venezuela: Tel.: 0-800-100-9123. Mattel Argentina, S.A., Av. Libertador 1000, Piso 11 - Oficinas 109 y 111, Vicente López - Prov. Buenos Aires. Tel.: 0800-666-3373. Mattel Colombia, S.A., Calle 123#-07 P5, Bogotá. Tel.: 01800-710-2069. Mattel Perú, S.A., Av. Juan de Arona # 151, Centro Empresarial Juan de Arona, Torre C, Piso 7, Oficina 704, San Isidro, Lima 27, Perú. RUC: 20425853865. Reg. Importador: 02350-12-IUE-DIGESA. Tel.: 0800-54744. E-mail Latinoamérica: servicio.clientes@mattel.com. Mattel do Brasil Ltda. - CNPJ: 54.558.002/0001-20 - Rua Verbo Divino, 1488 - 2º - Andar - 04719-904 - Chácara Santo Antônio - São Paulo - SP - Brasil. Serviço de Atendimento ao Consumidor: fone 0800 575 0780. E-mail: sac.matteldobrazil@mattel.com

Ⓟ D714,887, D781,964, D797,203, D841,101 1186 MJ, 1, NL



©2022 Microsoft Corporation. All Rights Reserved. Microsoft, Halo, the Halo logo, Xbox, the Xbox logo, and 343 Industries are trademarks of the Microsoft group of companies.

©2022 MEGA Brands &™ MEGA Brands.  
Printed in China / Imprimé en Chine AD-GYG60-01A

Mattel Canada Inc. Mississauga, Ontario L5R 3W2.  
MADE IN CHINA. FABRIQUÉ EN CHINE. FABRICADO NA CHINA. HECHO EN CHINA.  
ИЗГОТОВЛЕНО В КИТАЕ. ÇIN'DE ÜRETİLMİŞTİR. صنع في الصين

