



Barbie

Color
Reveal
Scent
Scenteur!



HHP89

TRAIN 'N WASH™ PETS ENTRAÎNEMENT DES ANIMAUX

BAÑO Y ENTRENAMIENTO DE MASCOTAS / TREINO E BANHO DE ANIMAIS DE ESTIMAÇÃO
TIERZENTRUM / НАБОР "ОБУЧЕНИЕ И УХОД ЗА ПИТОМЦАМИ™"



**Build
Construisez**
Construye | Constrói
Bauen | Стройте



Share | Partagez
Comparte | Partilha
Teilen | Делитесь

Devices not included | Appareils non inclus | Dispositivos não incluídos
Dispositivos não incluídos | Geräte nicht enthalten | Устройства не входят в комплект

**Play as you build!
Jouez en construisant !**

Juega mientras construyes!
Construção e brincadeira simultâneas!
Gleichzeitig bauen und spielen!
Строй и играй!



megaunboxed.com

**CHOOSE WHAT YOU
WANT TO BUILD FIRST!
CHOISISSEZ CE QUE VOUS
VOULEZ CONSTRUIRE EN PREMIER!**

¡ELIGE QUÉ QUIERES CONSTRUIR PRIMERO! • ESCOLHA O QUE VOCÊ QUER CONSTRUIR PRIMEIRO! KINDER
KÖNNEN AUSSUCHEN, WAS SIE ZUERST BAUEN WOLLEN! • ВЫБЕРИ, ЧТО ТЫ ХОЧЕШЬ СОБРАТЬ СНАЧАЛА!



P.4



P.24



P.34

WHAT WILL YOU REVEAL? QU'ALLEZ-VOUS DÉCOUVRIR?

¿QUÉ VAS A REVELAR? • O QUE VOCÊ VAI REVELAR?
WELCHE PUPPE KOMMT ZUM VORSCHIEIN? • КАКУЮ КУКЛУ ВЫ ОТКРОЕТЕ?

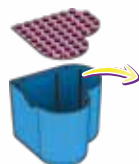



**LET'S BUILD THE
GROOMING STATION!**
**CONSTRUIÇONS LA ZONE
DE TOILETTAGE !**

¡VAMOS A CONSTRUIR UNA
ESTACIÓN DE ASEO!
VAMOS CONSTRUIR UMA ESTAÇÃO
DE LIMPEZA!
EINE PFLEGESTATION BAUEN!
ПОСТРОИМ САЛОН КРАСОТЫ
ДЛЯ ЖИВОТНЫХ!



CUSTOMIZE YOUR BARBIE® MICRO-DOLL!
PERSONNALISEZ VOTRE MICRO-POUPÉE BARBIE®!

¡PERSONALIZA TU BARBIE! • PERSONALIZE SUA BARBIE!
DIE BARBIE-FIGUREN INDIVIDUELL GESTALTEN! • СДЕЛАЙ СВОЮ ФИГУРКУ БАРБИ УНИКАЛЬНОЙ!





1



2



1



2



1

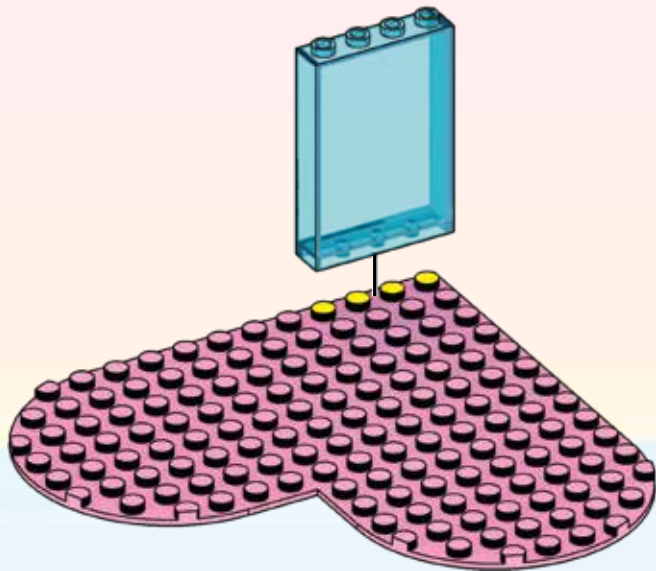
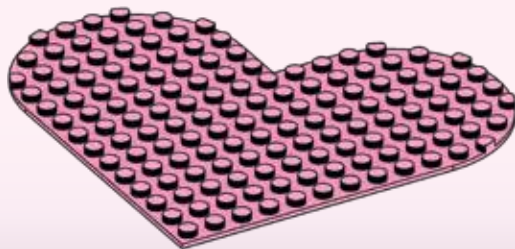
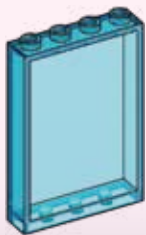

2

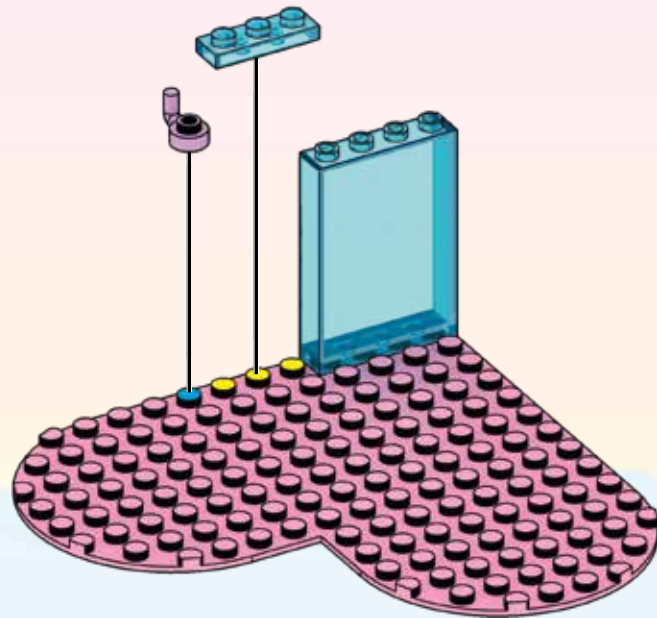

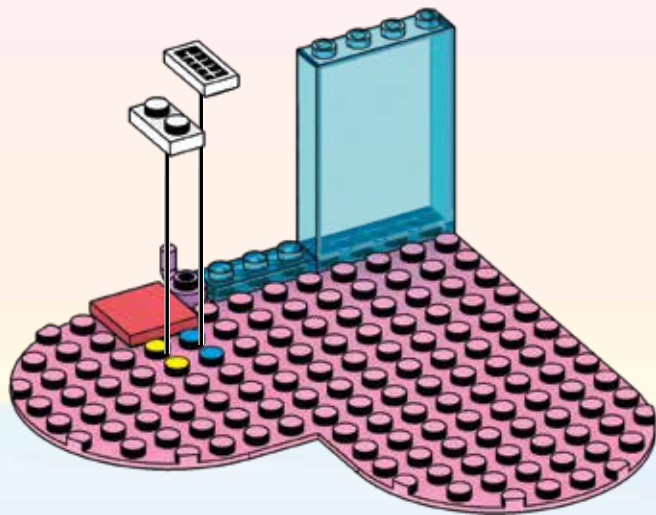
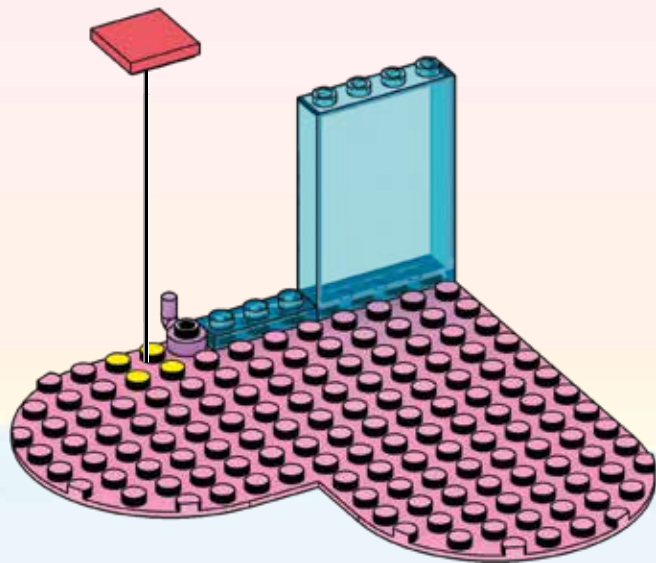
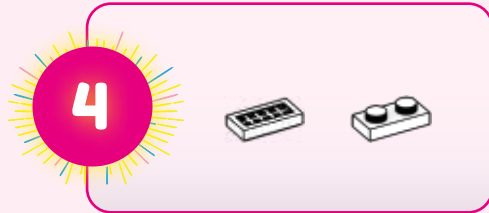
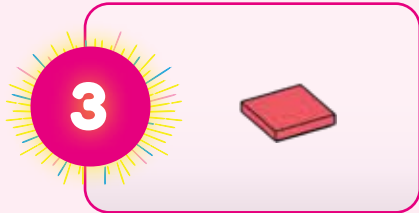

5

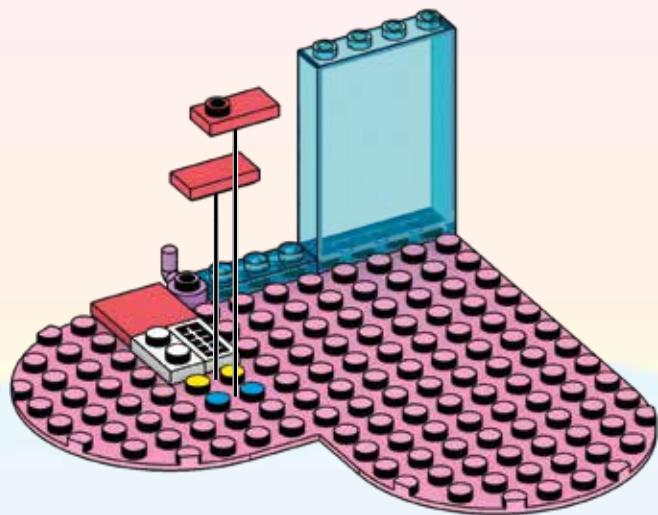

6

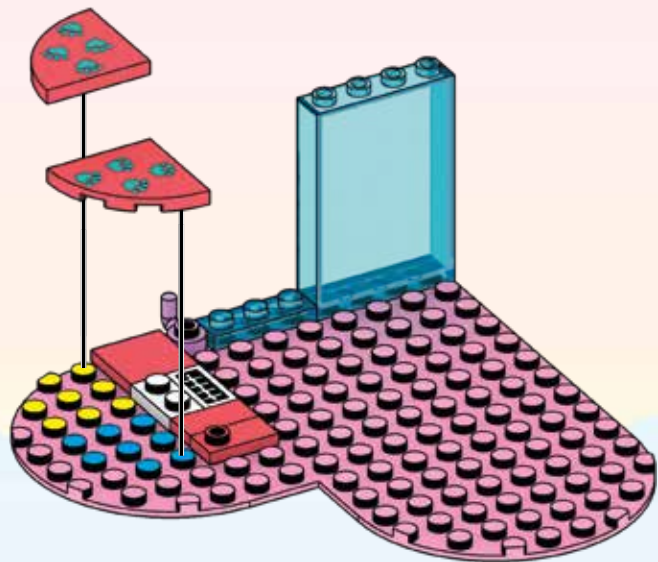

7

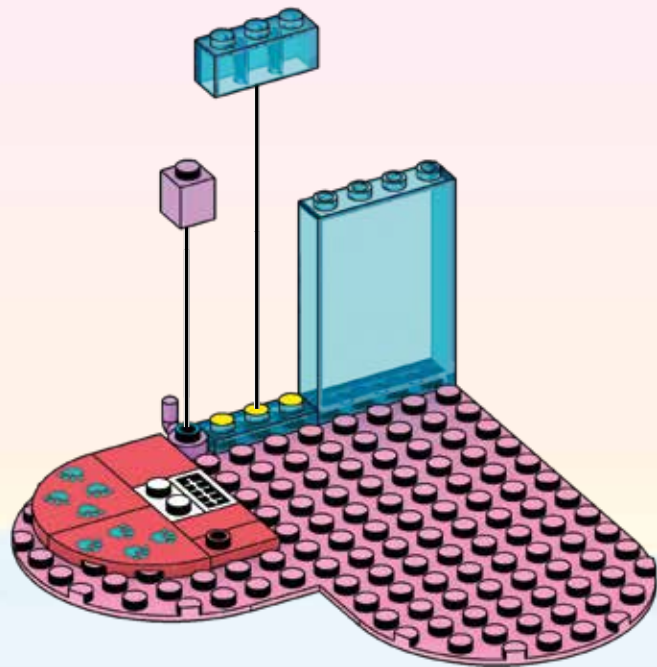

8

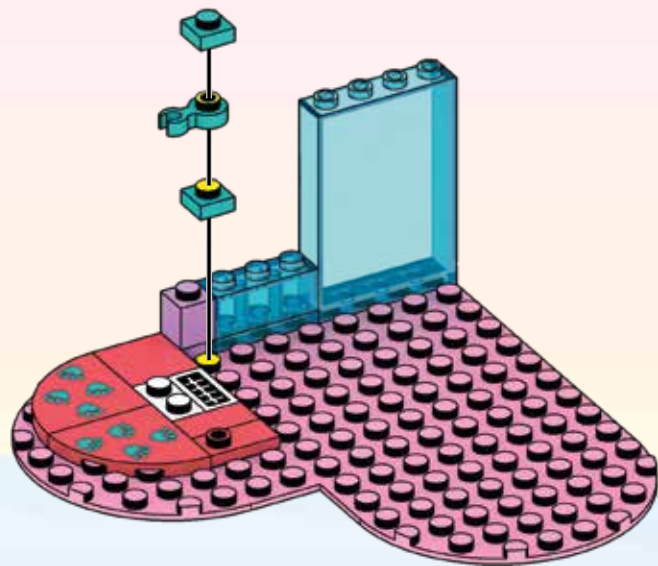

9

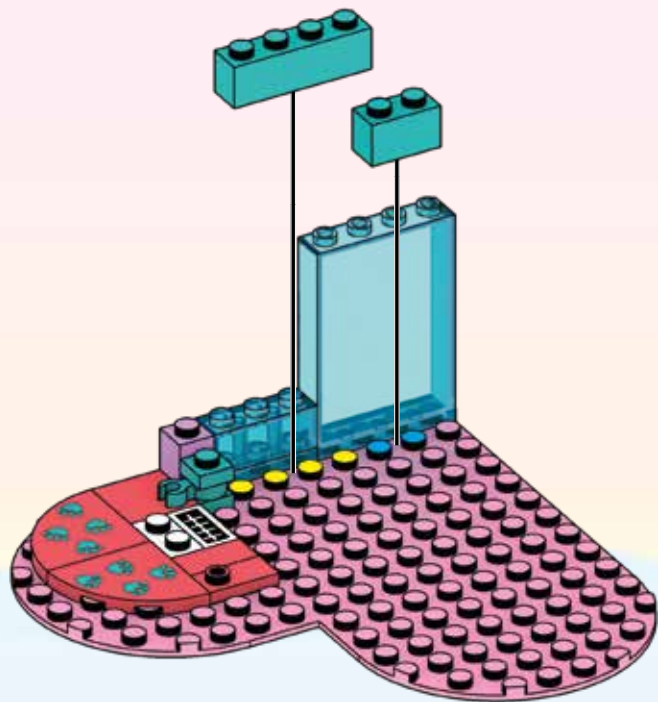
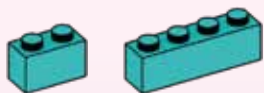

10

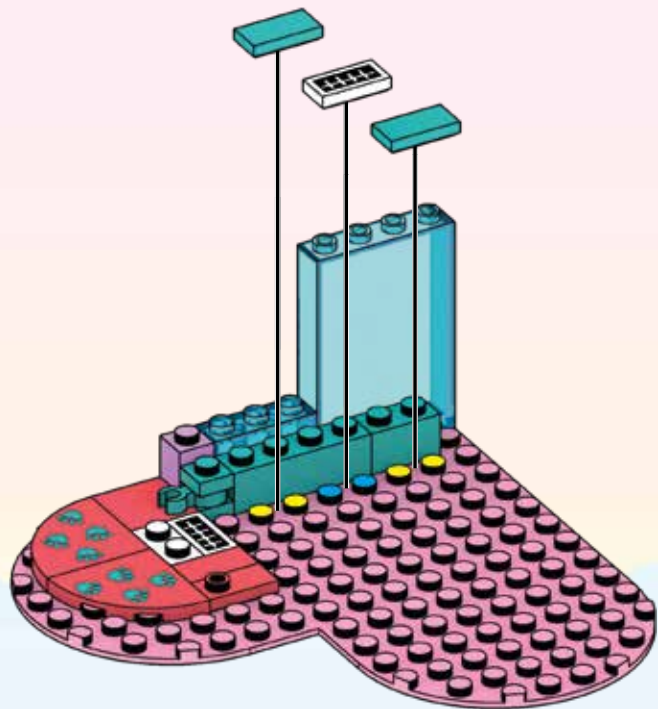

11



12

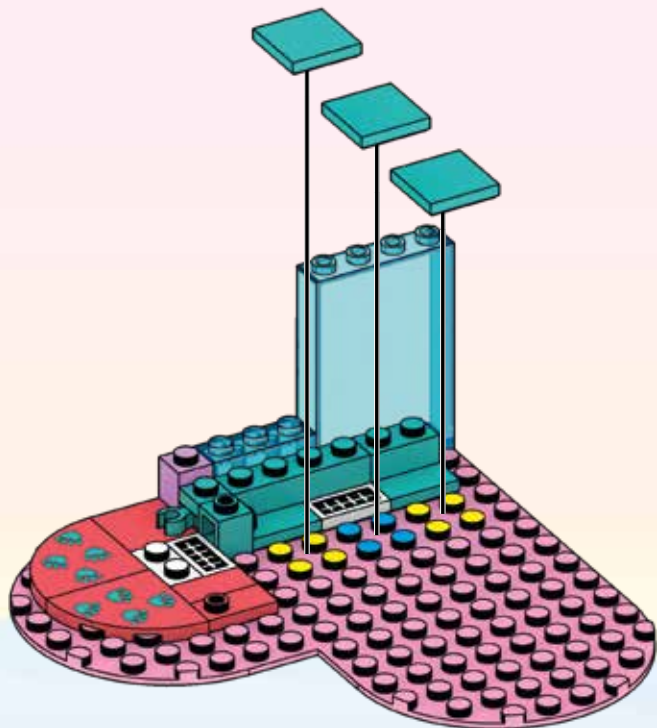
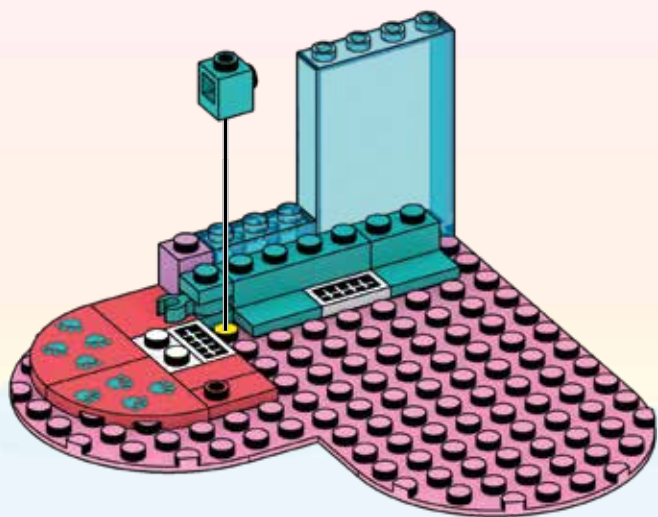
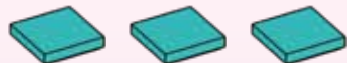

13

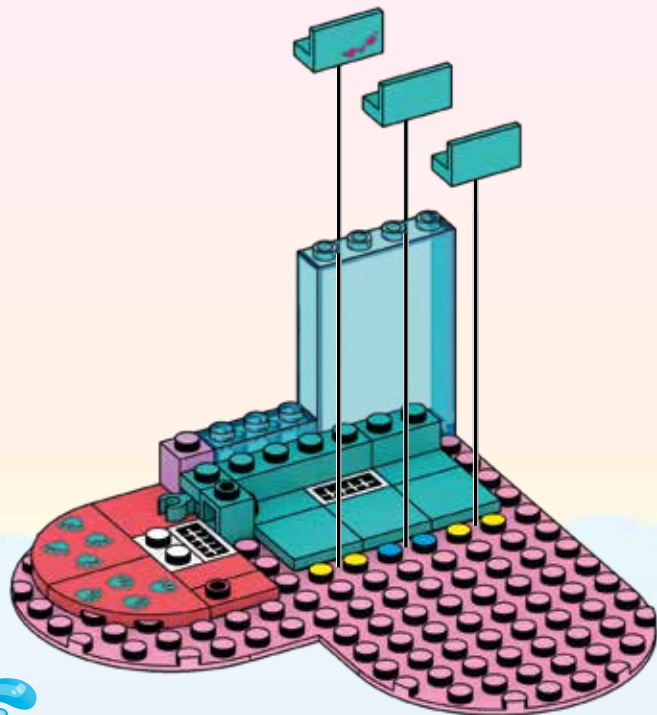

14

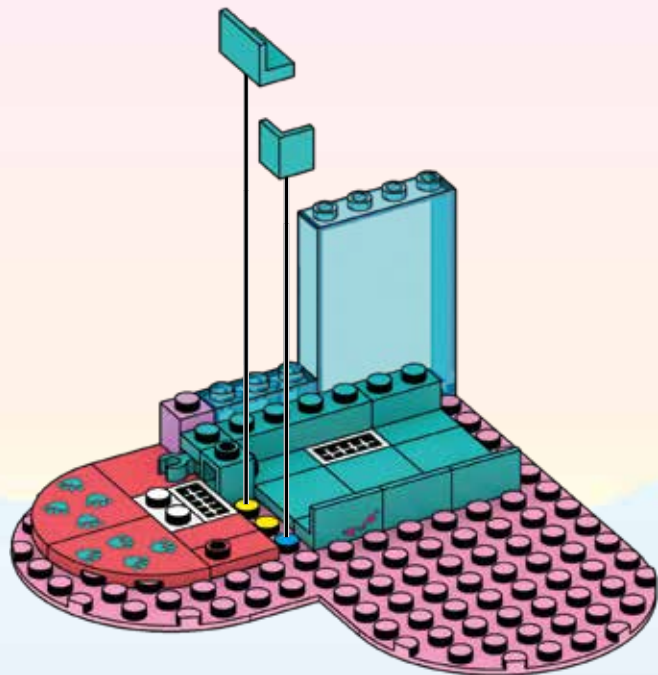

15

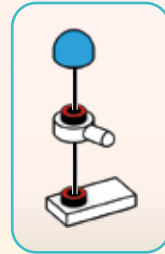
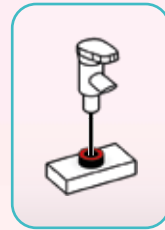
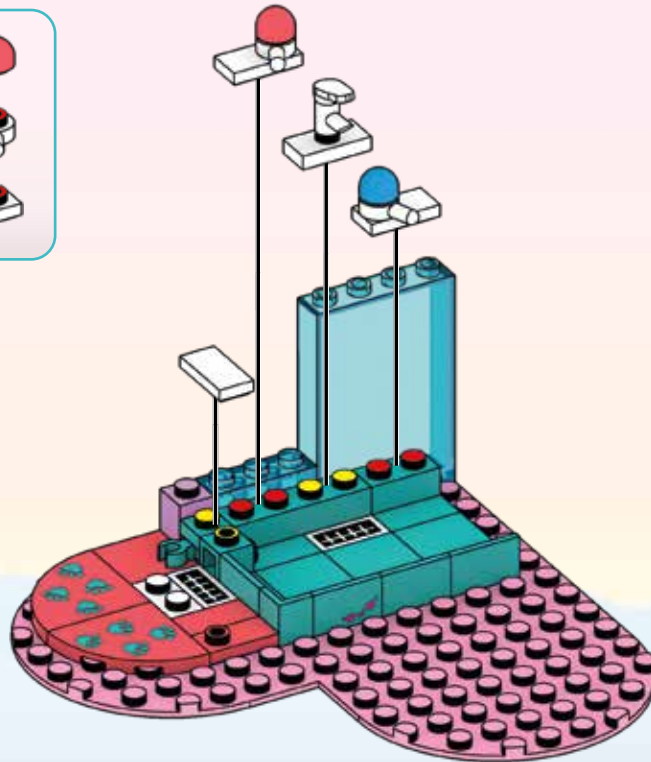
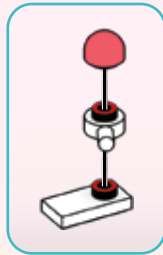

16

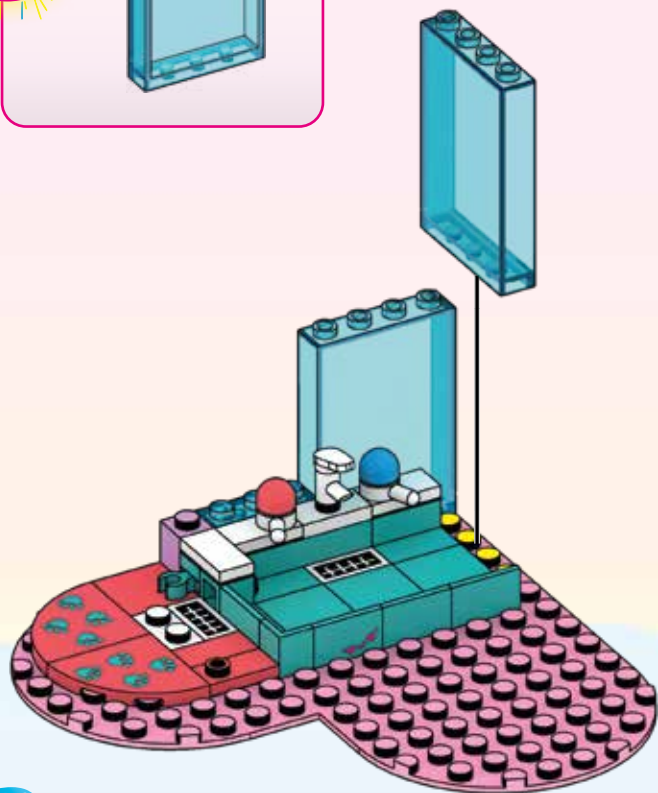
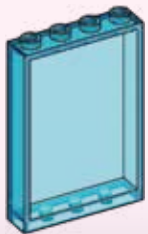

17

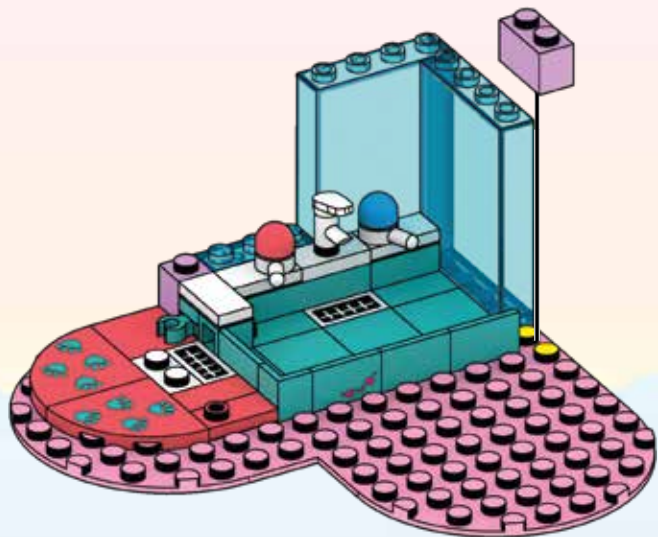

18

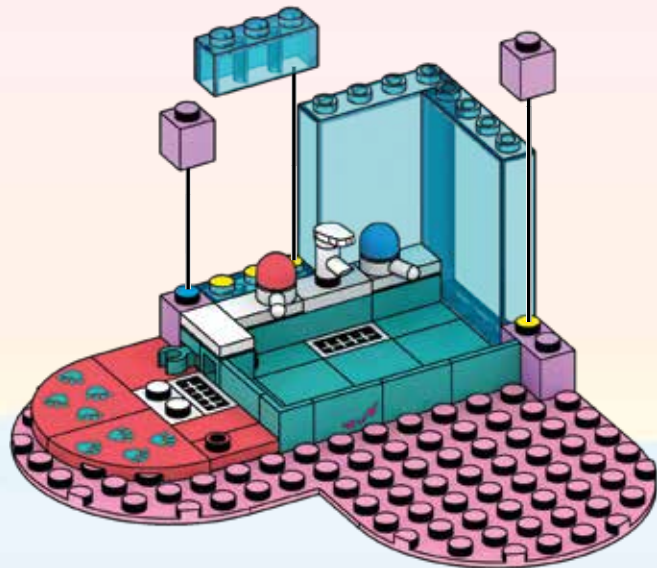

19

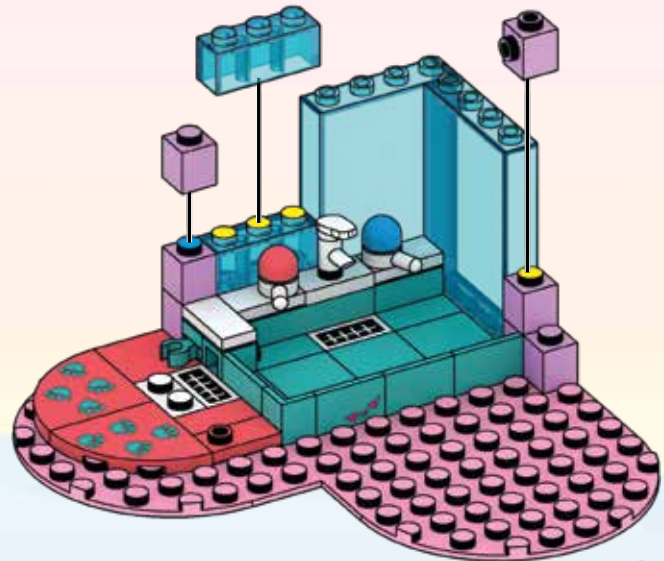

20

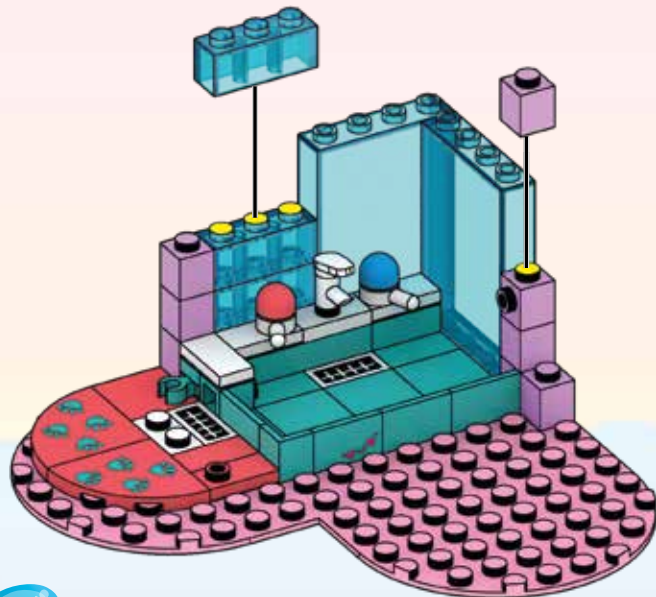

21

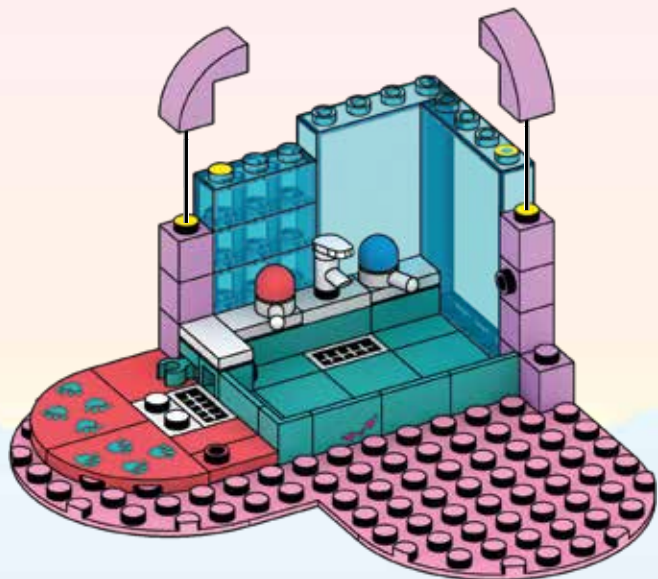

22

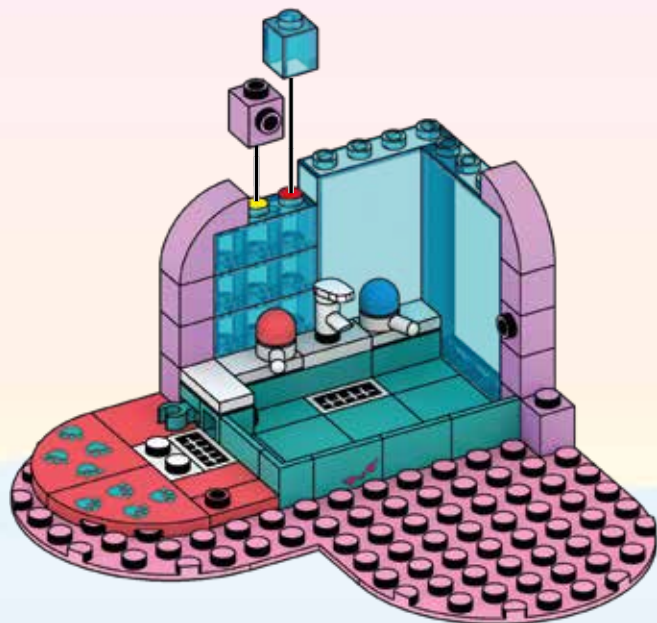

23

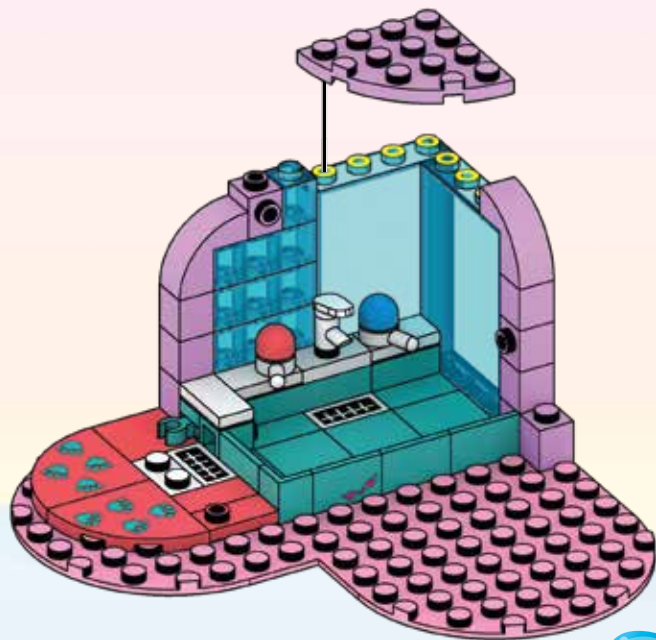

24

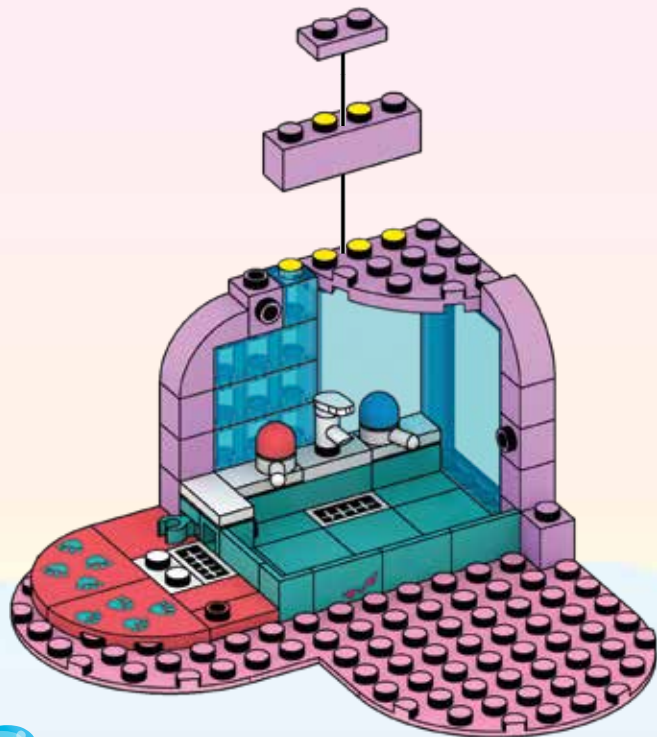
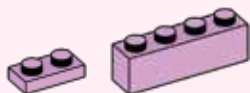

25

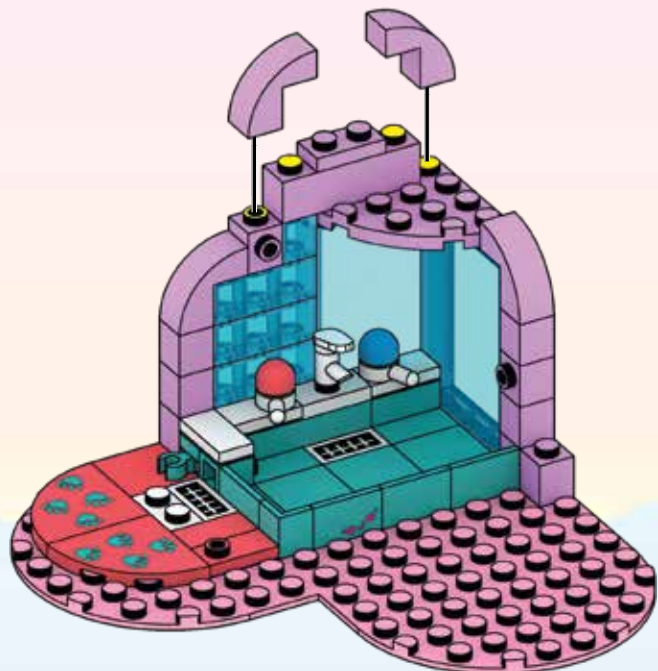

26

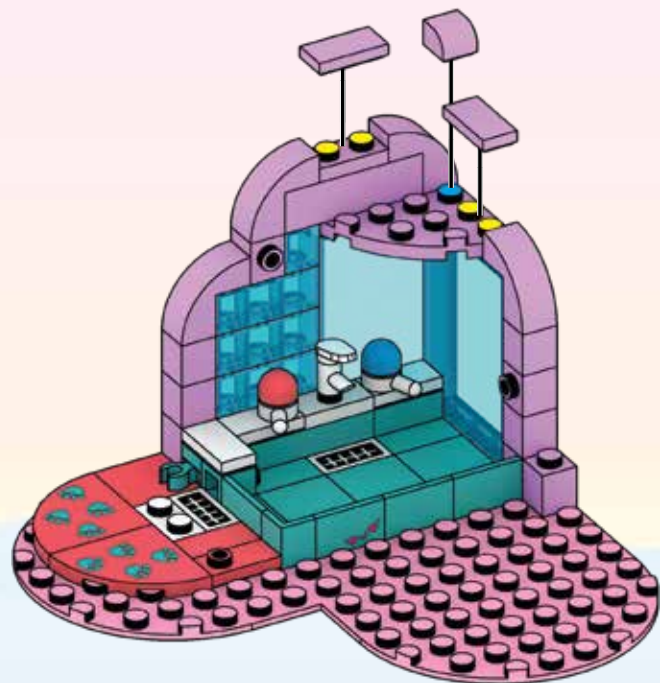

27

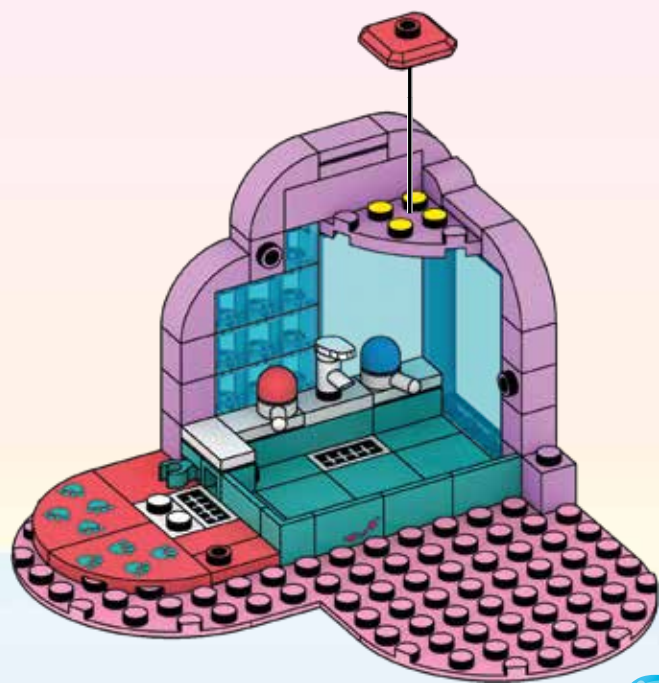

28

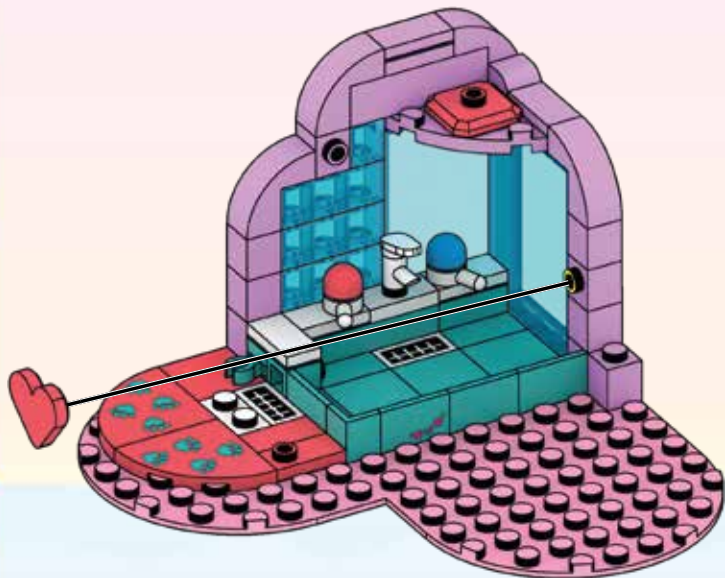

29

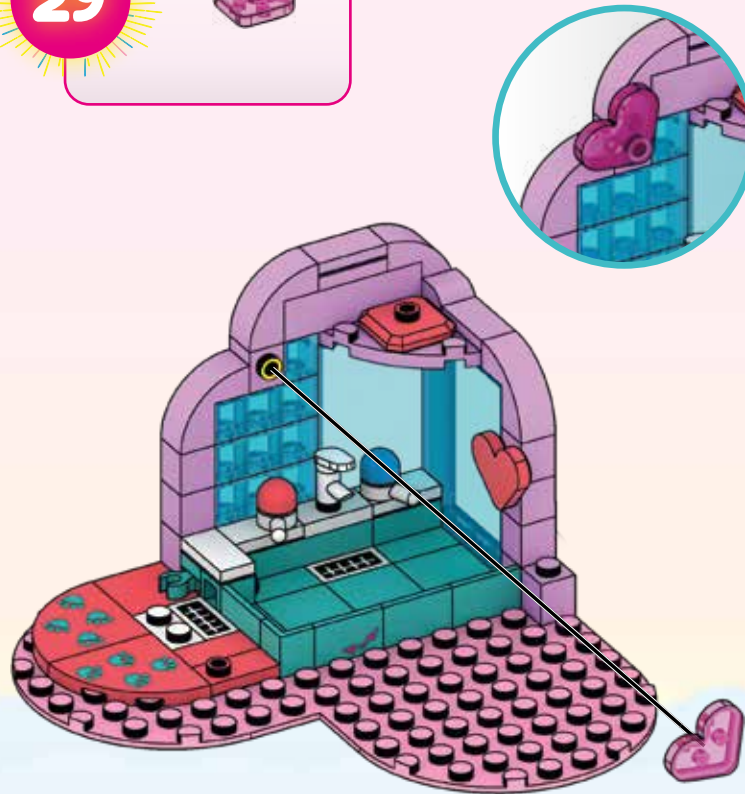

30

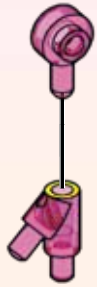

1



2



3



4

31

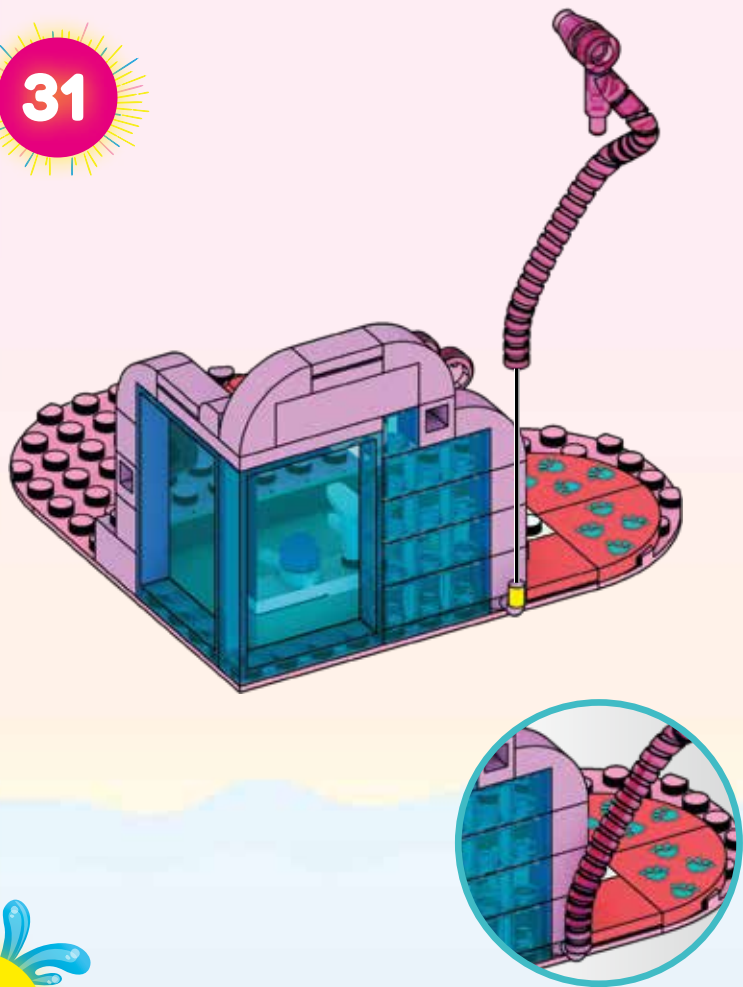

32

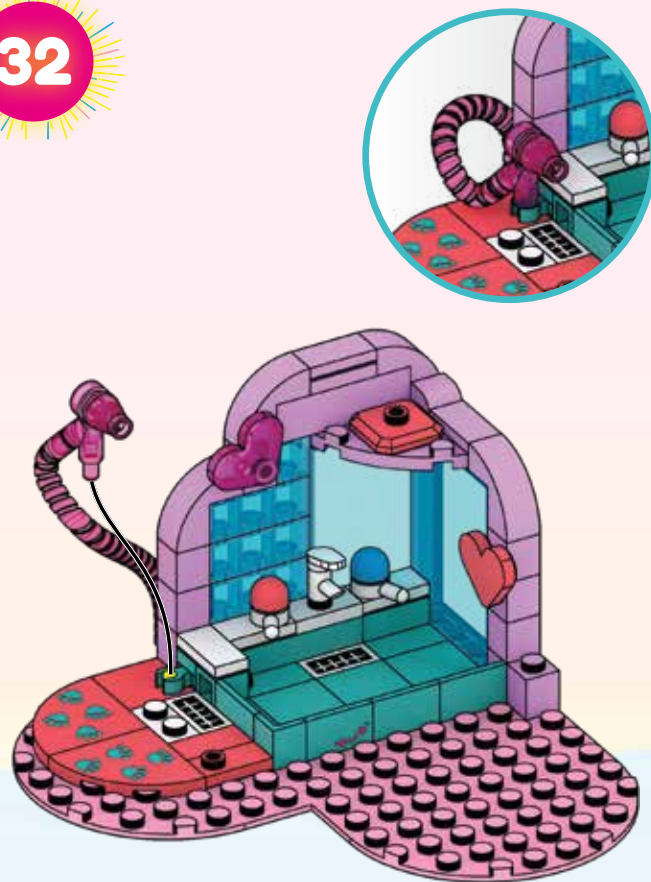

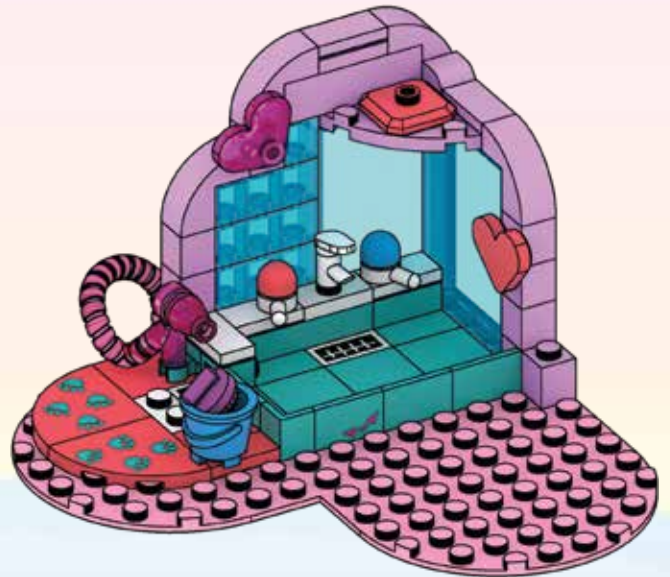
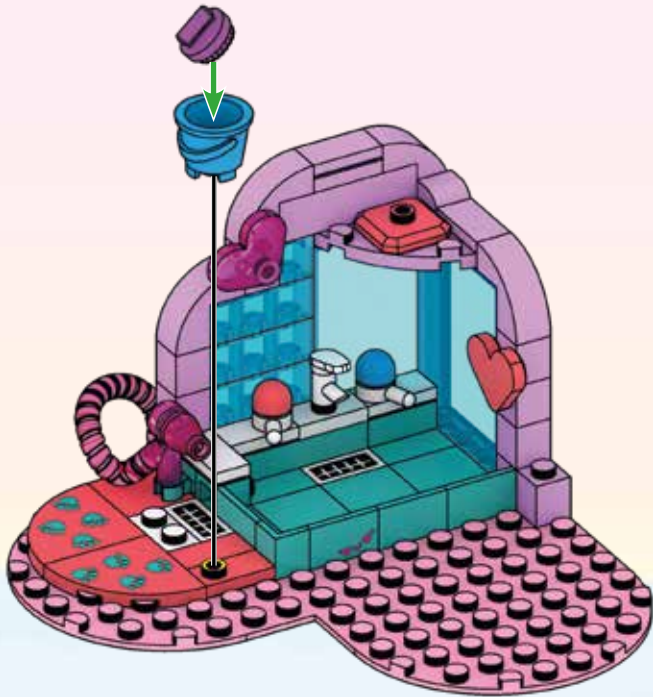



LET'S BUILD THE PLAYROOM! CONSTRUISONS LA SALLE DE JEU !

¡CONSTRUYAMOS EL CUARTO DE JUEGOS!
VAMOS CONSTRUIR O QUARTO
DE BRINCADEIRA!
EIN SPIELZIMMER BAUEN!
ПОСТРОИМ ИГРОВУЮ ПЛОЩАДКУ!



CUSTOMIZE YOUR BARBIE® MICRO-DOLL! PERSONALISEZ VOTRE MICRO-POUPEE BARBIE®!

¡PERSONALIZA TU BARBIE! • PERSONALIZE SUA BARBIE!
DIE BARBIE-FIGUREN INDIVIDUELL GESTALTEN! • СДЕЛАЙ СВОЮ ФИГУРКУ БАРБИ УНИКАЛЬНОЙ!



1



2

34

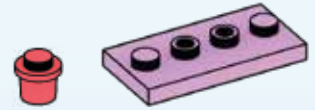

1



2



1



2

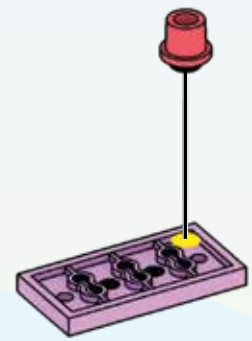

35

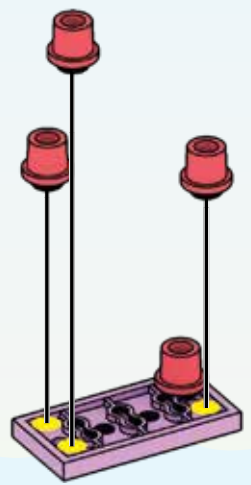

1

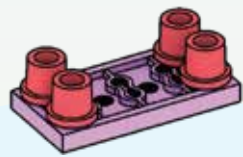

2

36

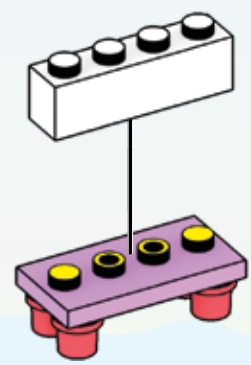
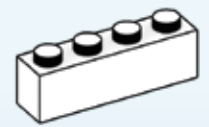

37

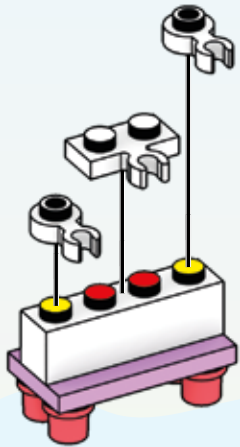

38

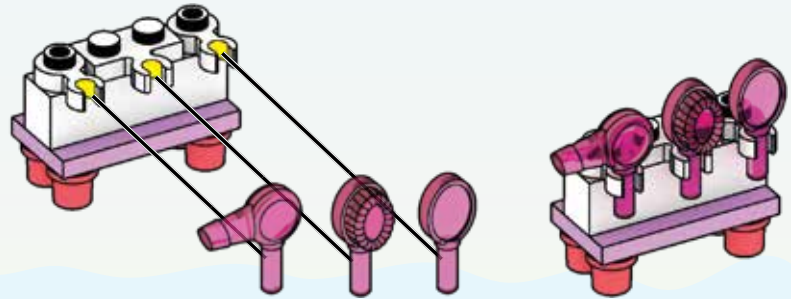

1

2

39

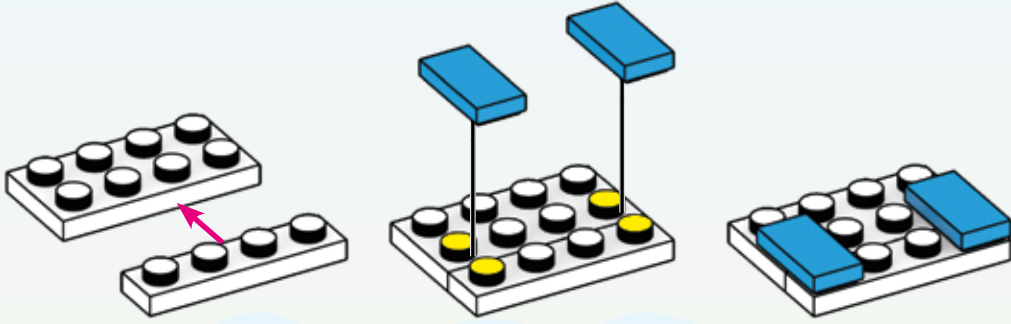
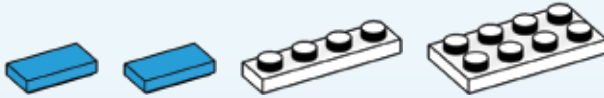

1

2

3

40

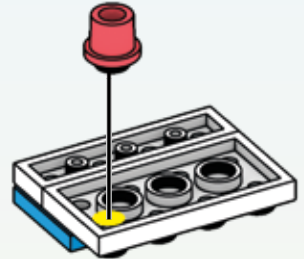

41

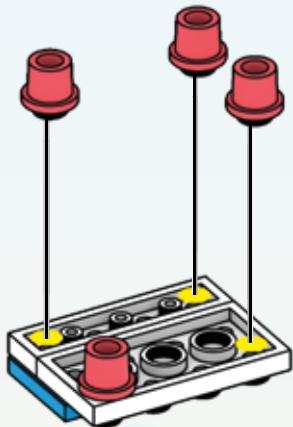

1

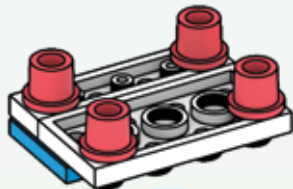

2

42

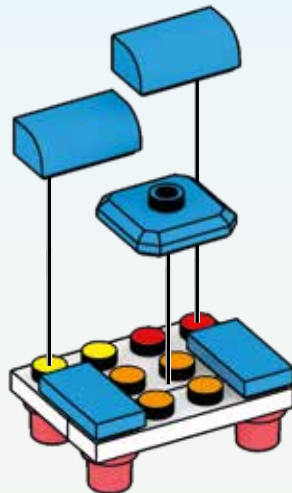

1



2

43

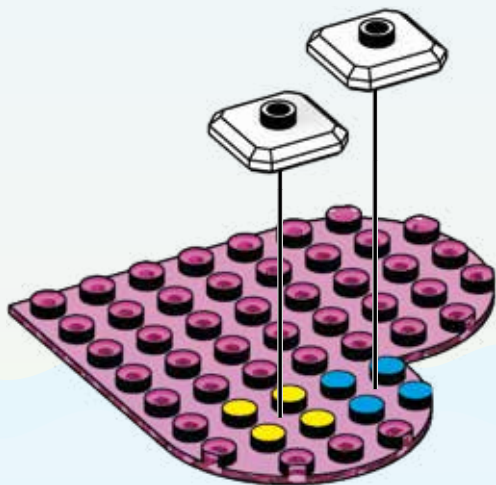

44

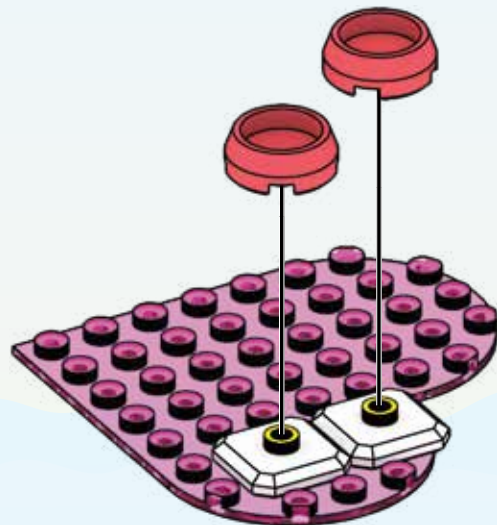

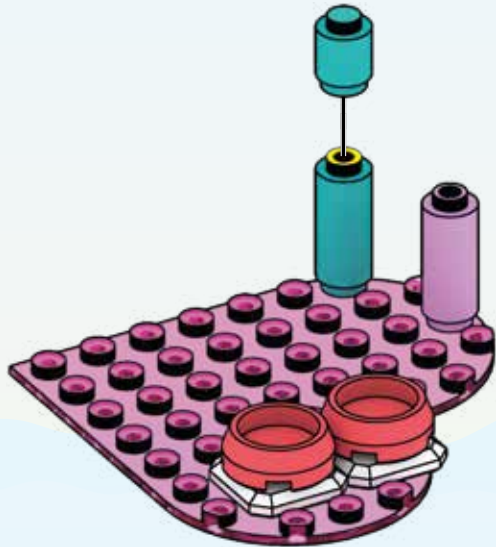
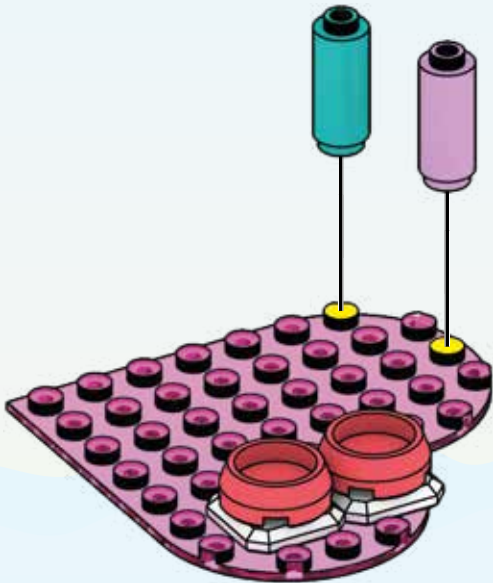

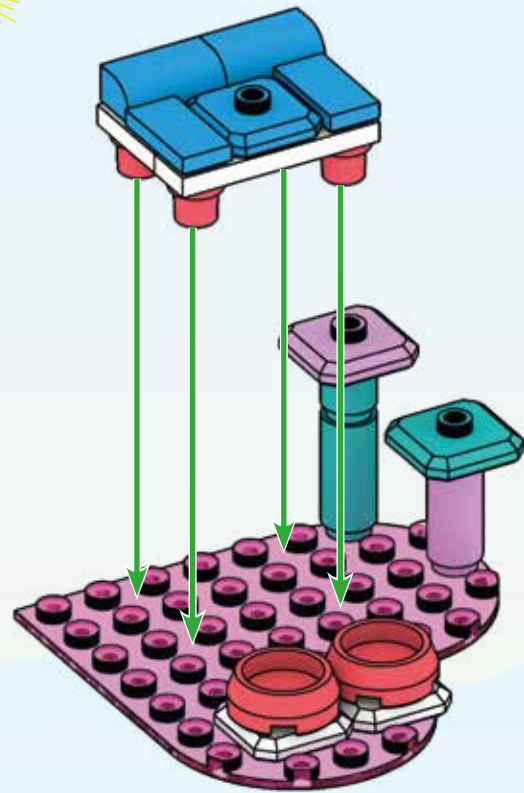
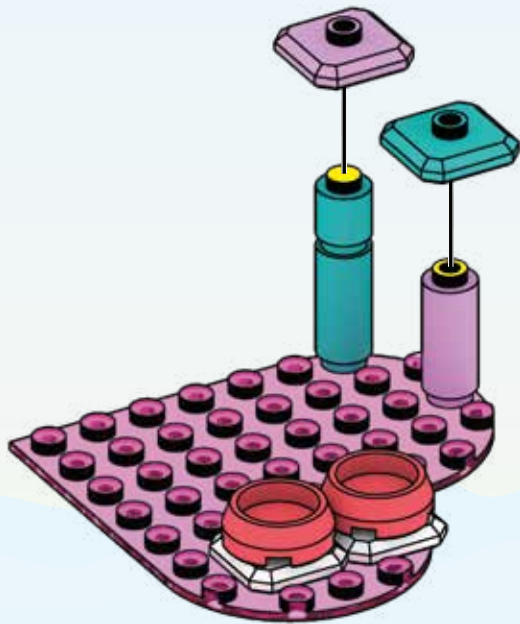
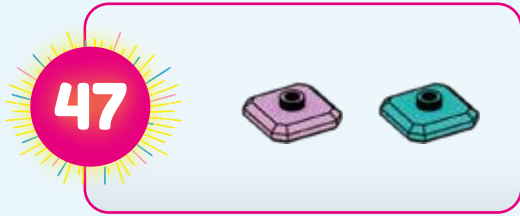

49

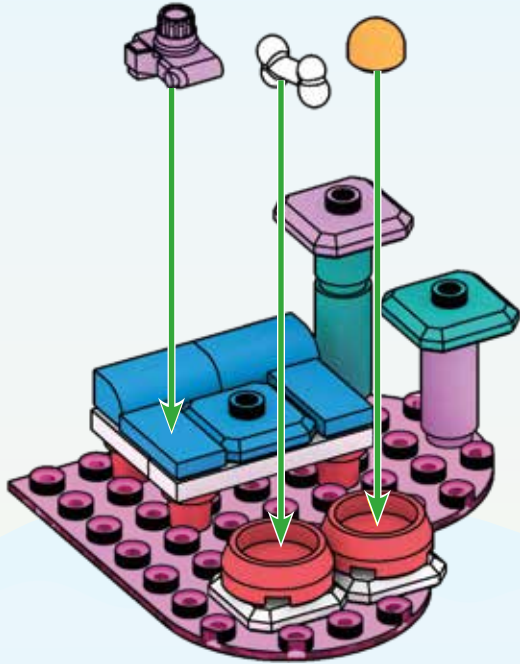
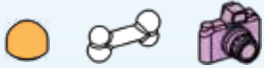

1

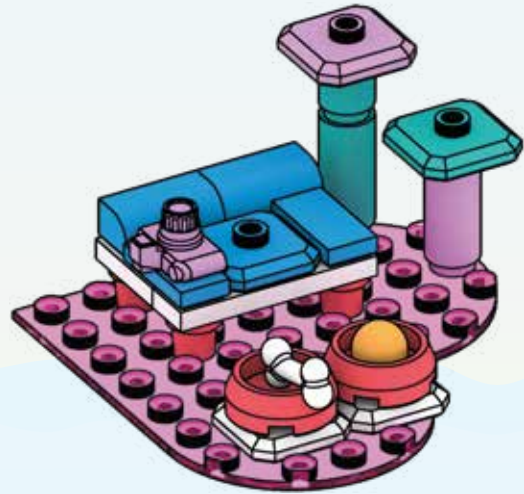

2



**LET'S BUILD THE SCOOTER &
TRAINING STATION!**
**CONSTRUISONS LE SCOOTER ET LA
STATION D'ENTRAÎNEMENT !**

**¡CONSTRUYAMOS LA MOTO Y LA ESTACIÓN DE
ENTRENAMIENTO!**

**VAMOS CONSTRUIR A ESTAÇÃO DE
TREINO E SCOOTER!**

**EINE MOTORROLLER- UND
TRAININGSSTATION BAUEN!**

**ПОСТРОИМ МОПЕД И ПЛОЩАДКУ
ДЛЯ ЖИВОТНЫХ!**



1



2



1



2



50

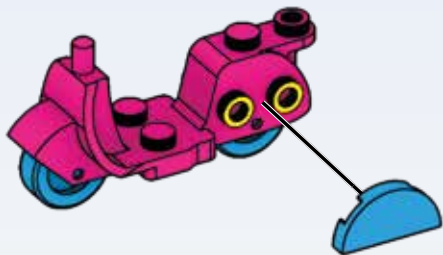

1

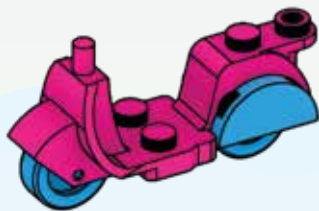

2

51

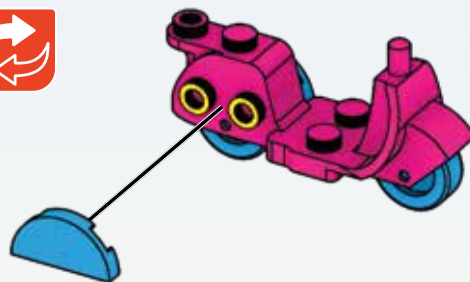

52

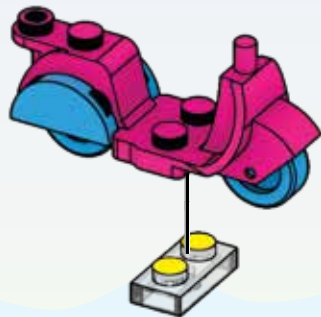

53

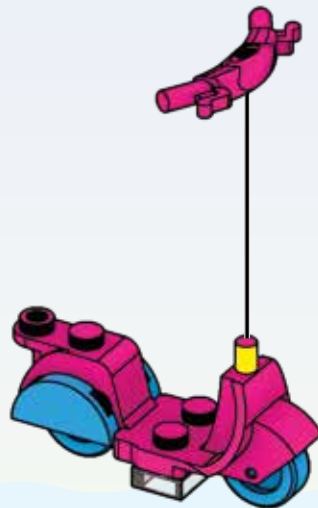

1

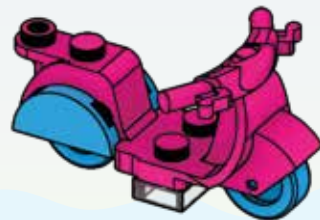

2

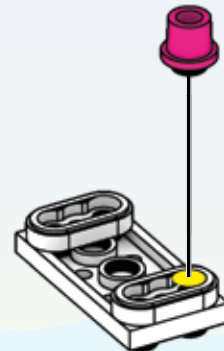
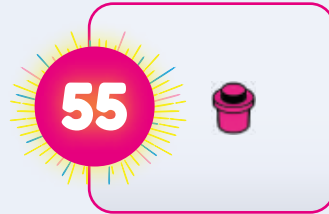
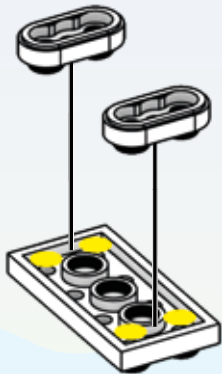
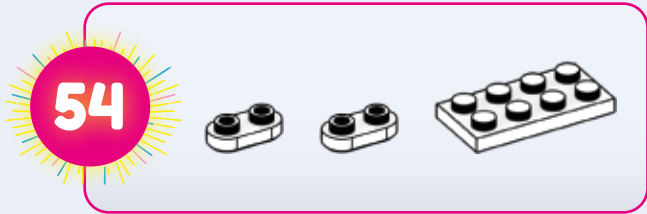

56

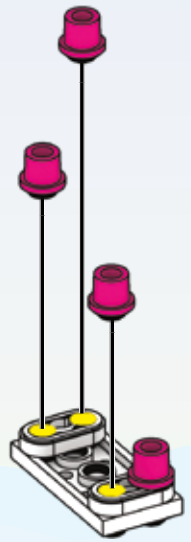

1

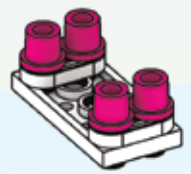

2



3

57

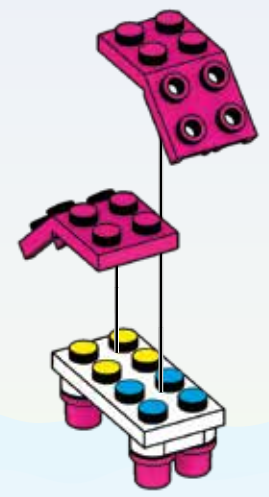
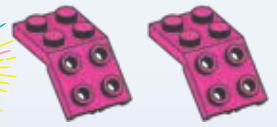

58



1



2

59

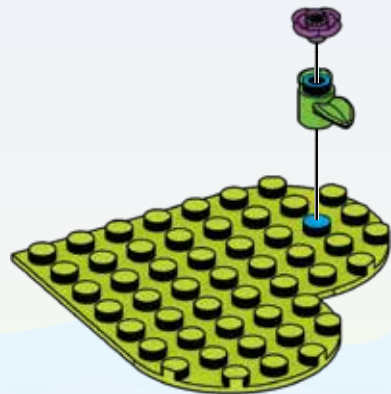
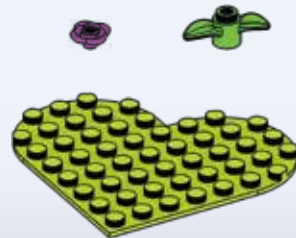

60

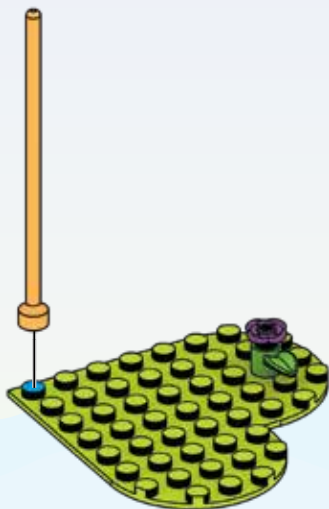

61

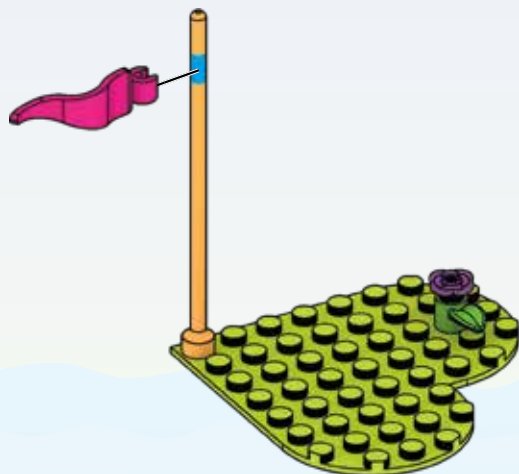

62



63

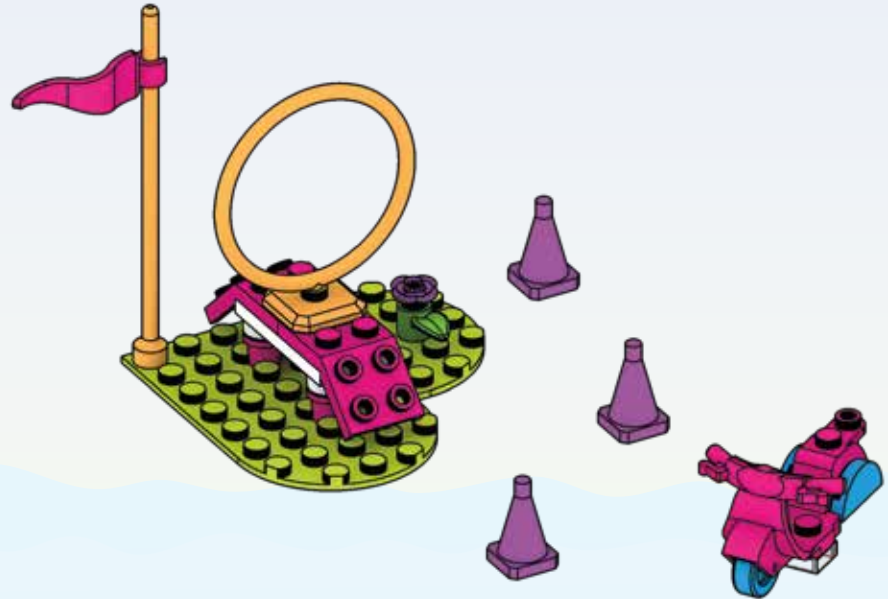

1



2

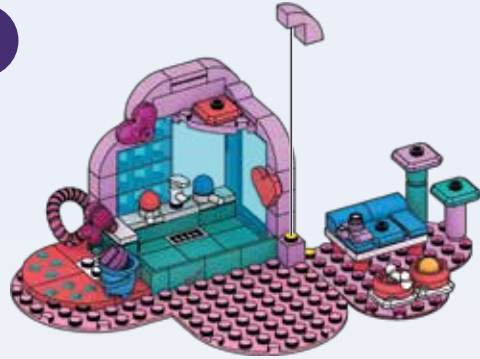

3

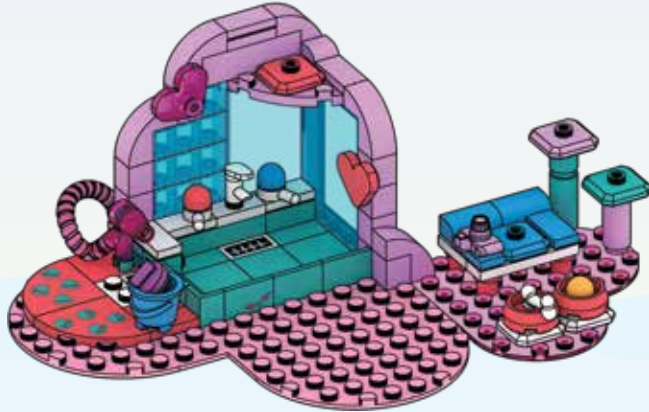

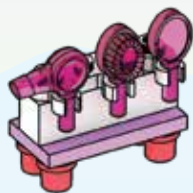
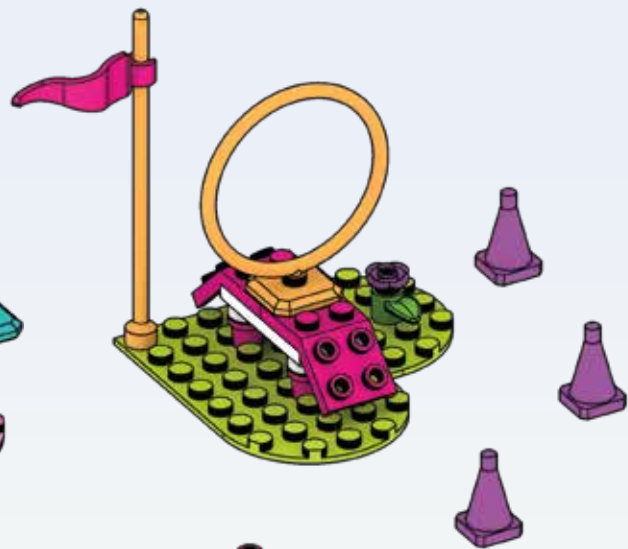
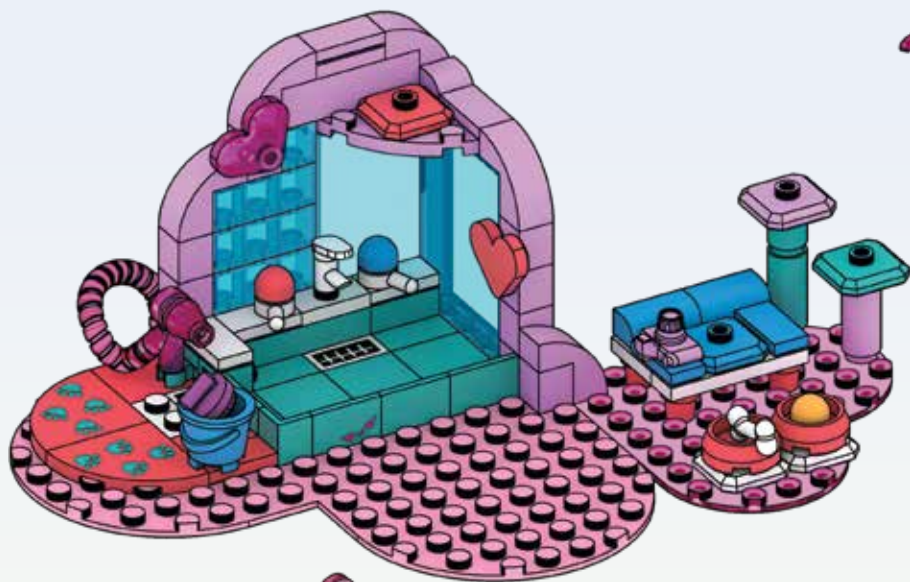

LET'S PLAY!
AMUSONS-NOUS!

¡AJUGAR! • ABRINCAR!
LASS UNS SPIELEN! • НАЧИНАЕМ ИГРУ!



1x
AM72954AEN



1x
AM0910CV



2x
AM12251E



2x
AM79288GX



1x
AM73758RQ



2x
AM03017GX



1x
AM09129ASY



1x
AM78219FM



1x
AM72973E



1x
AM01312AUZ



2x
AM022501ASY



2x
AM73758E



1x
AM09013CV



1x
AM09129CV



1x
AM78219RQ



1x
AM72931E



1x
AM79570ASY



2x
AM022501CV



1x
AM07590E



1x
AM09013ASY



1x
AM73974GX



1x
AM78219GX



1x
AM76959CV



1x
AM12251CV



1x
AM022501RQ



1x
AM09393ASY



1x
AM79278AUZ



5x
AM16682ASY



8x
AM81164RQ



1x
AM01086AXC



2x
AM01312E



2x
AM022501GX



1x
AM09393W



1x
AM72980AUZ



2x
AM72972RQ



4x
AM81164ATC



5x
AM01086ASY



2x
AM80174E



1x
AM022501E



1x
AM09393E



1x
AM72983AUZ



1x
AM73980AUZ



2x
AM03328CV



1x
AM07629CV



1x
AM72922ASY



2x
AM18756E



1x
AS-HHP89-02



1x
AM72982AUZ



1x
AM73980RQ



1x
AM17787ASY



2x
AM07629ASY



1x
AM73975AEN



1x
AM19660E



3x
AM07228CV



1x
AM73009FM



1x
AM73009ASY



2x
AM73009E



1x
AM73009GX



1x
AM73009CV



1x
AM73009RQ



1x
AM0948RQ



3x
AM0948CV



1x
AM81215AUZ



3x
AM15065AEN



1x
AM78726HT



1x
AM81094ATC



1x
AM01314AXC



4x
AM16384AXC



1x
AM04333AUZ



1x
AM16450ATC



1x
AM09593E



1x
AM01087E



1x
AM01087ASY



1x
AM01087CV

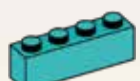

2x
AM16653ATC



2x
AM09493E



1x
AM01531ASY

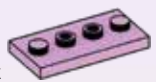

2x
AS-HHP89-01



1x
AM74680ASY



1x
AS-HHP89-05



1x
AM72844FM



2x
AM16311AXC



1x
X-HHP89-02



1x
AM81104BBG

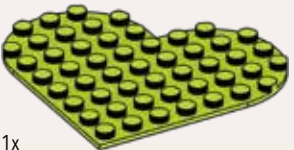

1x
AM81104AXF

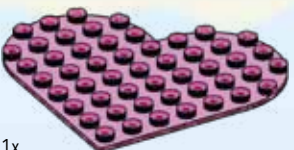

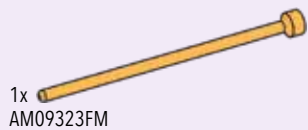

1x
AM09323FM

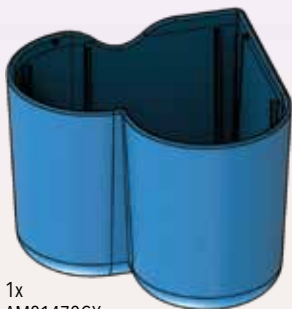

1x
AM81472GX

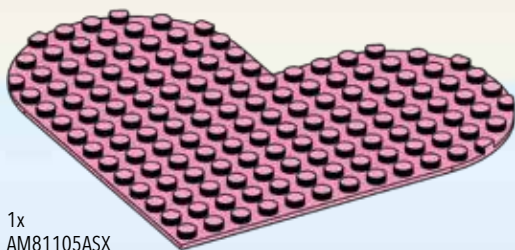

1x
AM81105ASX



1x
AS-HHP89-C



1x
AS-HHP89-H



1x
AS-HHP89-D



1x
AS-HHP89-E



1x
AS-HHP89-F



1x
AS-HHP89-G



1x
FIG-HHP89-A



1x
FIG-HHP89-B



1x
AS-HHP89-03



1x
AS-HHP89-04

Missing pieces? • Pièces manquantes?

¿Partes faltantes? • Perdeu peças?
Fehlen Teile? • Не хватает деталей?

support.megabrand.com

ATTENTION : DANGER
D'ÉTOUFFEMENT. - PRÉSENCE DE PETITS ÉLÉMENTS.
LE JOUET CONTIENT DES PETITES BALLE. NE
CONVIENT PAS AUX ENFANTS DE MOINS DE 3 ANS.

ATENÇÃO! NÃO INDICADO / NÃO
RECOMENDÁVEL PARA CRIANÇAS MENORES DE 3
(TRÊS) ANOS POR CONTER PARTE(S) PEQUENA(S) /
BOLA(S) PEQUENA(S) QUE PODE(M) SER ENGOLIDA(S)
OU ASPIRADA(S) PODENDO PROVOCAR ASFIXIA.

تحذير:
ليست مناسبة للأطفال دون سن 36 شهراً - قطع صغيرة.
كرات صغيرة. خطر الاختناق.

警告!
本产品内含小零件和小
球，可能产生窒息危险，
不适合3岁以下儿童使用。

⚠ WARNING : CHOKING HAZARD. - Small parts. Toy
contains small balls. Not for children under 3 years.
ADVERTENCIA: PELIGRO DE ATRAGANTAMIENTO. Juguete
no recomendado para menores de 3 años, porque contiene
piezas pequeñas / bolitas que podrían provocar asfixia en
caso de ser ingeridas o inhaladas por el/la niño/a.



AVVERTENZA: Piccole parti. Piccole palle. Rischio di soffocamento.
ACHTUNG: Kleine Teile. Kleine Kugeln. Erstickungsgefahr.
OSTRZEŽENIE: Male kuleczki. Niebezpieczeństwo zadławienia.
WAARSCHUWING: Kleine onderdelen. Kleine balletjes. Verstikkingsgevaar.
ПРЕДУПРЕЖДЕНИЕ: Мелкие детали. Маленькие шарики. Опасность
проглатывания. / ADVARSEL: Små dele. Små bolde/kugler. Kvælningfare.
VARNING: Smådelar. Små bollar. Kvävningsrisk.
ADVARSEL: Små deler. Små kuler. Kvelningsfare.
VAROITUS: Pieniä osia. Pieniä palloja. Tukehtumisvaara
ΠΡΟΣΟΧΗ: Μικρά κομμάτια. Μικρές μπάλετσες. Κίνδυνος Πνιγμού.
UYARI: Küçük parçalar. Küçük toplar. Yutma tehlikesi.
UPOZORNENÍ: Malé díly. Malé míčky. Nebezpečí udušení.
UPOZORNENIE: Malé casti. Malé guľôčky. Nebezpečenstvo zadusenia.
FIGYELMEZTETÉS: Kis alkatrészek. Kis labdák. Fulladásveszély.

警告:
のどにつまる危険 小さな部品が含まれています
小さな玉が含まれています。
3歳以下の子供には与えないで下さい。

Mattel Europa B.V., Gondel 1, 1186 MJ Amstelveen, Nederland. Mattel U.K. Limited, The Porter Building, 1 Brunel Way, Slough SL1 1FQ, UK. Mattel France, Parc de la Cerisaie, 1/3/5 allée des Fleurs, 94260 Fresnes Cedex. N° Cristal 0969 36 99 99 (Numéro non surtaxé) ou www.lesjouetsmattel.fr Mattel Belgium, Trade Mart, Atomiumsquare, Bogota 202 - B 275, 1020 Brussels. Gratis nummer België: 0800 - 16 936 - Gratis nummer Luxemburg: 800 - 22 784 - Gratis nummer Nederland: 0800 - 262 88 35. Deutschland : Mattel GmbH, Solmsstraße 4, D-60486 Frankfurt am Main. Schweiz: Mattel AG, Kirchstrasse 24, CH-3097 Liebefeld. Österreich: Mattel Ges.m.b.H., Campus 21, Liebermannstraße A01 404, A- 2345 Brunn/Gebirge. Mattel Italy Srl, Via Bracco, 6-MAC 6, 20159 Milano, Italy. Servizio assistenza clienti: Customersrv.italia@mattel.com - Numero verde 800 11 37 11. Mattel España, S.A., Arribau 200, 08036 Barcelona. cservice.spain@mattel.com Tel: 900 102 390 http://www.service.mattel.com/es. Mattel East Asia Ltd., Room 503-09, North Tower, World Finance Centre, Harbour City, Tsimshatsui, HK, China. Tel: (852) 3185-6500. Diimport & Diedarkan Oleh: Mattel Continental Asia Sdn Bhd. Level 19, Tower 3, Avenue 7, No. 8 Jalan Kerinchi, Bangsar South, 59200 Kuala Lumpur, Malaysia. Mattel South Africa (PTY) LTD, Office 102 I3, 30 Melrose Boulevard, Johannesburg 2196. Dystrybutor: Mattel Poland Sp. z o.o., Warsaw Trade Tower 34 p. ul. Chłodna 51, 00-867 Warszawa. Mattel Australia Pty. Ltd., 658 Church St., Richmond, Victoria, 3121. Consumer Advisory Service - 1300 135 312. Mattel AEBE, Εθνάρχου Μακαρίου 1, Κτήριο Κ-2, ΤΚ 17561, Παλιό Φάληρο. Mattel Oyuñcaçkçılık Tic. Ltd. Şti. İçerenköy Mah. Erkut Sok. A Blok No:12 Üner Plaza Kat:9-10 34752 Ataşehir İstanbul. Tel: 0216 570 75 00. Импортёр/Уполномоченная организация: ООО "МАТТЕЛ" Российская Федерация, 105120 Москва, 2-й Сыромятинский переулoк, 1; +7 495 287 79 39. Mattel Czech Republic s.r.o., The Forum, Václavské nám. 19, 11000 Praha 1. Mattel, 333 Continental Boulevard, El Segundo, CA 90245, USA. Consumer Services: 1-800-465-MEGA (6342). Mattel Canada Inc., Mississauga, Ontario L5R3W2. Consumer Services: You may call us free at/ Composez sans frais le 1-800-524-8697. Importador y distribuido por Mattel de México, S.A. de C.V., Miguel de Cervantes Saavedra No. 193, Pisos 10 y 11, Col. Granada, Alcaldía Miguel Hidalgo, C.P. 11520, México, Ciudad de México. R.F.C. MME-920701-NB3. Tels.: 59-05-51-00 Ext. 5206 ó 01-800-463-59-89. Mattel Chile, S.A., Avenida Américo Vespucio 501-B, Quilicura, Santiago. Tel.: 1230-020-6213. Servicio al consumidor Venezuela: Tel.: 0-800-100-9123. Mattel Argentina, S.A., Av. Libertador 1000, Piso 11 - Oficinas 109 y 111, Vicente López - Prov. Buenos Aires. Tel.: 0800-666-3373. Mattel Colombia, S.A., Calle 123#7-07 P5, Bogotá. Tel.: 01800-710-2069. Mattel Perú, S.A., Av. Juan de Arona # 151, Centro Empresarial Juan de Arona, Torre C, Piso 7, Oficina 704, San Isidro, Lima 27, Perú. RUC: 20425853865. Reg. Importador: 02350-12-JUE-DIGESA. Tel.: 0800-54744. E-mail Latinoamérica: servicio.clientes@mattel.com. Mattel do Brasil Ltda. CNPJ : 54.558.002/0001-20 - Rua Verbo Divino, 1488 - 2º. Andar - 04719-904 - Chácara Santo Antônio - São Paulo - SP - Brasil. Serviço de Atendimento ao Consumidor: fone 0800 575 0780. E-mail: sac.matteldobrazil@mattel.com



HKF90



HHP89



HPF48



HPF49



HPF50

Set(s) sold separately and subject to availability. / Ensemble(s) vendu(s) séparément. Certains produits peuvent ne pas être commercialisés. / Se vende(n) por separado y está(n) sujeto(s) a disponibilidad. / Conjunto(s) vendido(s) em separado e sujeito(s) a disponibilidade. / Set in vendita separatamente, secondo disponibilità. / Das/Die Set(s) sind separat erhältlich. / Zestaw(ów) sprzedawany(e) oddzielnie w zależności od dostępności. / Set(s) apart verkrijgbaar en afhankelijk van beschikbaarheid. / Набор(-ы) продаются отдельно, при наличии. / Sæt sælges separat og så længe lager haves. / Seten säljs separat så länge lagret räcker. / Settet/settene selges separat så langt lageret rekker. / Pakkaus/pakkaukset myydään erikseen, saatavuus voi vaihdella. / Το(α) σετ πωλούνται ξεχωριστά και ανάλογα με τη διαθεσιμότητα. / Setler ayrı olarak satılır ve stoklarla sınırlıdır. / Set (sety) se prodává (prodávají) samostatně dle aktuální nabídky. / Súprava/-y sa predáva(jú) samostatne a podľa dostupnosti. / A készlet(ek) külön kapható(k), az elérhetőség változhat. / セット商品は別売りになります。在庫状況は別途ご確認お願いします。 / تباع المجموعة أو المجموعات على حدة وتخضع لتوافرها.

每套单独发售，按供货情况决定。

Color change will last longer if you do not expose this toy to intense heat or direct sunlight for prolonged periods of time.

Le changement de couleur peut tenir plus longtemps si vous n'exposez pas ce jouet à une chaleur intense ou à la lumière directe du soleil pendant de longues durées.

El cambio de color durará más tiempo si no expone este juguete al calor intenso o a la luz solar directa durante períodos de tiempo largos.

A mudança de cor durará mais se você não expor este brinquedo ao calor intenso ou à luz solar direta por períodos prolongados.

L'effetto cambia colore durerà più a lungo se questo giocattolo non viene esposto al calore intenso o alla luce diretta del sole per periodi di tempo prolungati.

Die Farbveränderung ist nachhaltiger, wenn das Spielzeug nicht über einen längeren Zeitraum hinweg starker Hitze oder direkter Sonneneinstrahlung ausgesetzt wird.

Zmiana koloru będzie trwała, jeśli zabawka nie będzie długookresowo narażana na wysoką temperaturę lub bezpośrednio działanie promieni słonecznych.

De verandering van kleur gaat langer mee als je dit speelgoed niet voor langere tijd aan intense hitte of direct zonlicht blootstelt.

Цвет будет дольше оставаться без изменений, если вы не будете подвергать эту игрушку продолжительному и сильному воздействию тепла или прямого солнечного света.

Farveændringen vil vare længere, hvis du ikke udsætter legetøjet for intens varme eller direkte sollys i længere perioder.

Färgändringen varar längre om du inte utsätter leksaken för stark värme eller direkt solljus under längre tidsperioder.

Färgändringen vil vare lenger hvis du ikke utsetter denne leken for sterk varme eller direkte sollys over lengre tid.

Värimuutos kestää pidempään, jos et altista tätä lelua voimakkaalle kuumuudelle tai suoralle auringonvalolle pitkiä aikoja.

Η αλλαγή χρώματος θα διαρκέσει περισσότερο εάν δεν εκθέτετε αυτό το παιχνίδι σε έντονη ζέση ή άμεσο ηλιακό φως για παρατεταμένες χρονικές περιόδους.

Bu oyuncuğu uzun süre yoğun ısıya veya doğrudan güneş ışığına bırakmadığınız sürece, renk değişimi uzun sürecek.

Změna barvy vydrží déle, pokud tato hračka nebude delší dobu vystavena intenzivnímu teplu nebo přímému slunečnímu záření.

Zmena farby vydrží dlhšie, ak túto hračku nebudete dlhší čas vystavovať intenzívnemu teplu alebo priamemu slnečnému žiareniu.

A színváltozás tovább tart, ha nem teszi ki ezt a játékot hosszú ideig erős hő vagy közvetlen napfény hatásának.

色変化は本玩具を長時間にわたり猛烈な暑さや直射日光にさらさなければより長く持続します。

تغيير لون بدون طويلاً في حال تجنب تعرض هذه اللعبة لدرجات الحرارة العالية أو ضوء الشمس المباشر لفترات زمنية طويلة.

如果玩具能避免长时间暴露于高温或阳光直射下，变色的有效时间会更长。

To avoid burns do not use water that is too hot, above 43°C (110°F). Water toys sometimes get messy. Protect play surfaces before use. Drain, rinse, clean and dry all items thoroughly before storing. Dissolvable paint may stain fabrics and other surfaces. Avoid contact with carpet, clothing, wall and furniture. If staining occurs, raise with soap (not included) and warm water.

Pour éviter tout risque de brûlure, n'utilisez pas d'eau trop chaude (plus de 43 °C). Les jouets d'eau peuvent éclauber. Protégez les surfaces de jeu avant toute utilisation. Égouttez, rincez, lavez et séchez tous les éléments minutieusement avant de les ranger. La peinture soluble peut tacher certains tissus et autres surfaces. Évitez tout contact avec la moquette, les vêtements, les murs et les meubles. En cas de tache, rincez au savon (non inclus) et à l'eau tiède.

Para evitar quemaduras, no utilizar agua demasiado caliente (por encima de 43 °C). Los juguetes que requieren agua pueden ensuciar la superficie de juego. Se debe proteger antes de empezar a jugar. Es necesario limpiar, aclarar y secar todas las piezas antes de guardar el juguete. La pintura disolvente puede manchar o adherirse a algunos tejidos y otras superficies. Se recomienda evitar el contacto con alfombras, moqueta, ropa, paredes y muebles. Si se producen manchas, lavar con jabón (no incluido) y agua templada.

Para evitar queimaduras, não utilizar água demasiado quente, acima dos 43 °C. Os brinquedos que requerem a utilização de água podem sujar a área de brincadeira. Proteger a área de brincadeira antes de brincar. Lavar, enxaguar, limpar e secar bem todos os acessórios antes de guardar. A tinta dissolúvel pode manchar os tecidos e outras superfícies. Evitar o contacto com tapetes, roupa, paredes e mobília. Se provocar manchas, enxaguar com sabão (não incluído) e água morna.

Per prevenire le ustioni, non usare acqua troppo calda, oltre 43°C. I giochi ad acqua possono creare disordine. Proteggere le superfici di gioco prima dell'utilizzo. Svuotare, risciacquare, pulire e asciugare accuratamente tutte le componenti prima di riporle. La vernice solubile può macchiare tessuti e altre superfici. Evitare il contatto con tappeti, abiti, pareti e mobili. In caso di macchie, risciacquare con sapone (non incluso) e acqua calda.

Um Verbrennungen zu vermeiden, kein Wasser benutzen, das zu heiß ist (über 43°C). Wasserspielzeuge können spritzen! Die Spielfläche vor dem Spielen abdecken. Nicht auf Oberflächen spielen, die durch Wasser Schaden nehmen können. Alle Spielteile vor dem Weglegen gründlich säubern und trocknen. Die lösliche Farbe kann auf einigen Stoffen und anderen Oberflächen Flecken hinterlassen. Nicht mit Teppich, Kleidung, Wänden oder Möbeln in Berührung bringen. Etwaige Flecken mit warmem Wasser und Seife (nicht enthalten) auswaschen.

Aby uniknąć oparzeń, nie używaj zbyt gorącej wody (o temperaturze powyżej 43°C). Zabawki, którymi można bawić się przy użyciu wody, mogą powodować nieporządek. Przed rozpoczęciem zabawy zabezpiecz przeznaczoną do niej powierzchnię. Opróżnij z wody, oplucz, oczyść i wysusz wszystkie części zabawki przed ich schowaniem. Rozpuszczalna farba może plamić tkaniny i inne powierzchnie. Unikaj kontaktu z dywanami, odzieżą, ścianami i meblami. W przypadku wystąpienia zabrudzeń spłucz je ciepłą wodą z mydłem (nie znajduje się w zestawie).

Gebruik, om brandwonden te voorkomen, geen water warmer dan 43°C. Bij het spelen met water kan er nogal eens wat nat worden. Dek voor het spelen het speelgedeelte goed af. Voor het opbergen alle onderdelen leeg laten lopen, schoonspoelen en goed afdrogen. Oplosbare verf kan vlekken veroorzaken op stoffen en andere oppervlakken. Vermijd contact met tapijt, kleding, wanden en meubels. Als ergens vlekken in komen, speel je deze af met zeep (niet meegeleverd) en warm water.

Во избежание ожогов не используйте слишком горячую воду, температура которой превышает 43°C. Игрушки, предназначенные для игр с водой, иногда становятся причиной беспорядка. Перед началом игры подготовьте все необходимое для защиты поверхностей игровой зоны. Перед тем как убрать изделия на хранение, ополосните, почистите и протрите их насухо. Растворимая краска может оставить пятна на тканях и других поверхностях. Избегайте контакта с коврами, одеждой, стенами и мебелью. Если пятна появились, отстирайте их в теплой воде при помощи мыла (не входит в комплект).

Undgå forbrændinger ved ikke at bruge vand, der er over 43 °C. Når man leger med vandlegetøj, kan legeområdet blive vådt. Beskyt legeområdet inden brug af legetøjet. Tøm, skyl, rengør og tør alle dele grundigt, inden de lægges væk. Oploselig farve kan efterlade pletter på stof og andre overflader. Undgå kontakt med tæpper, tøj, vægge og møbler. Skyl efter med varmt sæbevand (medfølger ikke), hvis der kommer pletter.

Undvik brännskador, använd inte vatten som är varmare än 43°C. Vattenleksaker kan orsaka spill. Skydda underlaget före lek. Töm, skölj, tvätta och torka alla delar innan du lägger undan dem för förvaring. Vattenlöslig färg kan ge fläckar på tyger och andra material. Undvik kontakt med mattor, tyger, väggar och möbler. Om fläckar uppstår, skölj med tvål (ingår inte) och varmt vatten.

For å unngå forbrenninger må du ikke bruke vann som er varmere enn 43 °C. Vannleker kan medføre mye søl. Beskytt lekeflatene før bruk. Tøm, skyll, rengjør og tørk alle delene grundig før oppbevaring. Den oppløselige malingen kan lage flekker på stoff og andre overflater. Unngå kontakt med tepper, klær, vegger og møbler. Hvis det blir flekker, skyller du med såpe (medfølger ikke) og varmt vann.

Vältä palovammoja – älä käytä liian kuumaa vettä (yli 43 °C). Vesileikeistä saattaa syntyä sotkua. Suojaa leikkipaikka ennen leikin aloitusta. Tyhjennä, huuho, puhdista ja kuivaa kaikki osat hyvin ennen kuin panet ne säilöön. Maali voi tahrata kankaita ja muita materiaaleja. Varo, ettei sitä joudu matolle, vaatteille, seinille eikä huonekaluille. Poista tarvittaessa tahrat saippualla ja lämpimällä vedellä.

Για να αποφύγετε εγκαύματα μη χρησιμοποιείτε πολύ ζεστό νερό άνω των 43°C. Κάποιες φορές τα παιχνίδια με νερό προκαλούν ακαταστασία. Προστατέψτε την επιφάνεια του παιχνιδιού πριν από τη χρήση. Καθαρίστε και στεγνώστε καλά όλα τα αντικείμενα πριν την αποθήκευσή τους. Η διαλυτή μπογιά μπορεί να λερώσει υφάσματα και άλλες επιφάνειες. Αποφύγετε την επαφή με χαλιά, ρούχα, τοίχους και έπιπλα. Αν γίνει λεκές, καθαρίστε τον με ζεστό νερό και σαπούνι (δεν περιλαμβάνεται).

Yanma riskini önlemek için ürünü 43°C'den yüksek sıcaklıkta su ile kullanmayın. Suyu oynanan oyuncaklar etrafı ıslatabilir. Oyuncakçı kullanmadan önce oyun alanını ıslanmaya karşı koruyun. Oyun setini kaldırmadan önce tüm parçaların suyunu süzün, parçaları durulayın, temizleyin ve kurutun. Çözünür boyalar, kumaşları ve diğer yüzeyleri lekeleyebilir. Ürünü halı, giysi, duvar ve mobilyalara temas ettirmeyin. Lekelenen yüzeyi sabun (ürüne dahil değildir) ve ılık suyla temizleyin.

Nepoužívejte příliš horkou vodu (o teplotě vyšší než 43 °C), abyste předešli opaření. Hračky na vodu mohou způsobit nepořádek. Před použitím zakryjte povrchy, kde si budete hrát. Před uložením všechny předměty opláchněte, vyčistěte, nechte je okapat a důkladně vyschnout. Rozpustná barva může zanechat skvrny na tkaninách a jiných površích. Zabraňte kontaktu s koberci, oděvy, stěnami a nábytkem. Skvrny od barvy odstraníte opláchnutím teplou vodou s mýdlem (není součástí balení).

Nepoužívajte príliš horúcu vodu s teplotou nad 43°C (110°F), aby sa predišlo popáleniu. Hračky do vody občas spôsobia neporiadok. Pred použitím zabezpečte hraciu plochu pred poškodením. Pred uložením všetky diely dôkladne vyprázdňte, opláchnite, očistite a vysušte. Rozpustná farba môže zašpiniť textilie a iné povrchy. Zamedzte kontaktu s kobercom, odevom, stenami a nábytkom. V prípade znečistenia opláchnite mydlom (nie je súčasťou balenia) a teplou vodou.

Az égési sérülések elkerülése érdekében a víz ne legyen nagyon forró, hőmérséklete ne haladjon meg a 43°C fokot. A vízi játékokkal játszós gyerekek kisebb-nagyobb rendetlenséget okozhatnak. Használát előtt gondoskodjon a játszótér felület védelméről. Tárolás előtt ürítse ki, öblítse le, tisztítsa meg és hagyja teljesen megszáradni a játék minden részét. A feloldódó festék elszínezheti a szöveteket és más felületeket. Lehetőleg ne érjen hozzá szőnyeghez, ruházathoz, falhoz és bútorokhoz. Ha foltot hagyva, öblítse le szappannal (nem tartozék) és meleg vízzel.

やけどしないように、43度以上の熱すぎないお湯をご使用ください。水を使用したおもちゃは周囲を汚す可能性があります。周囲をぬらさないように注意し、使用後は水道水で洗いたオルでふいて乾かしてください。色素が周囲を汚す可能性があります。カーペット、衣服、壁や家具などにつかないようにしてください。汚れがついたらすぐに洗剤をとしかしたぬるま湯でふいてください。

يجب عدم استخدام الماء الساخن جداً الذي تتجاوز حرارته 43 درجة مئوية (110 فهرنهايت) لتفادي حدوث أية حروق. أحياناً، قد تسبب الألعاب المائية بعض الفوضى. يجب تأمين ساحات اللعب قبل الاستخدام. يجب تصفية كافة قطع الألعاب وتجنيفها وشطفاها وتنظيفها قبل تخزينها. تترك ألوان الطلاء بفعلاً على الأنسجة وغيرها من الأسطح. يجب تجنب ملامسة السجاد والملابس والجدار والأثاث. في حال حدوث البقع يجب الغسل بالماء الدافئ والصابون (غير متضمن).

防止水温太高导致烫伤，请不要使用温度大于43摄氏度（110华氏度）的水。在水中玩耍的玩具通常较容易弄脏。请在玩耍前好好保护玩具表层。在存储玩具之前请将玩具中的水彻底排开，进行清洗以及烘干。可溶解的涂层可能会弄脏纺织物品或者其他物体的表面。防止与地毯，衣物，墙壁以及家具接触。如果发生弄脏的情况，请用肥皂（产品不包含）以及温水进行清洗。

DISCOVER, DELIGHT AND DREAM WITH MEGA™ BARBIE® COLOR REVEAL! UN MONDE DE DÉCOUVERTES, DE PLAISIRS ET DE RÊVES VOUS ATTEND AVEC BARBIE® COLOR REVEAL



¡DESCUBRE, DISFRUTA Y SUEÑA CON BARBIE® COLOR REVEAL DE MEGA™!
DÉSCUBRA, SONHE E DELICIE-SE COM A BARBIE® COLOR REVEAL DA MEGA™
ENTDECKEN, FREUEN UND TRÄUMEN MIT MEGA BARBIE COLOR REVEAL!
ОТКРЫВАЙТЕ НОВЫЙ МИР, РАДУЙТЕСЬ И МЕЧТАЙТЕ С НАБОРОМ
MEGA™ BARBIE® COLOR REVEAL!

©2022 MEGA Brands &™ MEGA Brands.
Printed in China / Imprimé en Chine

AD-HHP89-01



UK
CA

1186 MJ, 1, NL

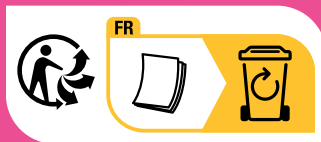

Mattel Canada Inc. Mississauga, Ontario L5R 3W2.
MADE IN CHINA. FABRIQUÉ EN CHINE. FABRICADO NA / HECHO EN CHINA.
ИЗГОТОВЛЕНО В КИТАЕ. ÇIN'DE ÜRETİLMİŞTİR. صنع في الصين

BARBIE® and associated trademarks and trade dress are owned by, and used under license from Mattel. ©2022 Mattel.

