



HALO

CHOOSE YOUR WARTHOG REBUILD
CHOISISSEZ VOTRE WARTHOG
ELIGE TU WARTHOG - ESCOLHE A TEU WARTHOG
WARTHOG NACK BELIEBEN GESTALTEN
ВЫБЕРИТЕ СВОЕГО ВЕРПЯ



*Instructions included for main model only. Other build(s) can be found at megaunboxed.com / Instructions incluses pour le modèle principal uniquement. Les instructions pour l'(les) autre(s) modèle(s) de construction se trouvent sur le site megaunboxed.com



HHC38

Red Team Warthog Rescue

Red Team et la Mission de Sauvetage du Warthog

Warthog de rescate del Equipo Rojo / Warthog de resgate da Equipe Vermelha

Red Team Warthog Fahrzeug / Набор "Спасательная миссия красной команды на Вепре"

HALO
UNIVERSE



**Build
Construisez**

Construye | Constrói
Bauen | Стройте



Share | Partagez

Comparte | Partilha | Teilen | Делитесь

Devices not included | Appareils non inclus | Dispositivos no incluído
Dispositivos não incluídos | Geräte nicht enthalten | Устройства не входят в комплект

**Get the rebuild steps!
Accédez aux instructions
de reconstruction !**

¡Consigue los pasos de reconstrucción!
Obtém os passos de reconstrução!
Jetzt die zweite Baumöglichkeit
entdecken!
Получите дополнительные
инструкции по
сборке игрушки!



megaunboxed.com



Most models can be built one at a time. / La plupart des modèles peuvent être construits un à la fois. / La mayoría de modelos se pueden construir de uno en uno. / A maioria dos modelos pode ser construída separadamente. / La maggior parte dei modelli possono essere realizzati uno per volta. / Die meisten Modelle können eines nach dem anderen gebaut werden. / Większości modeli nie da się budować jednocześnie z innymi. / De meeste modellen kunnen één voor één gebouwd worden. / Большинство моделей могут быть собраны по одной за раз. / De fleste modeller kan bygges enkeltvis. / De flesta modeller kan byggas en i taget. / De fleste modellene kan bygges en om gangen. / Useimmat mallit voidaan rakentaa yksi kerrallaan. / Τα περισσότερα μοντέλα μπορούν να κατασκευασθούν ένα ένα. / Modellerin çoğu ayrı ayrı inşa edilmeyi gerektirebilir. / Většinou lze najednou sestavit pouze jeden model. / Väčšina modelov môže byť zostavená iba raz. A modellek többségéből egyszerre csak egy építhető. /ほとんどのモデルは、一度に一つを組み立てることができます。 / يمكن تركيب التصميم الواحد تلو الآخر.

大多數型號可一次性建構



1

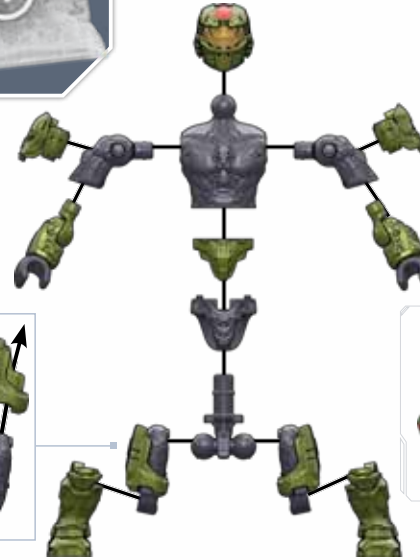

1

2



*Nur für das Hauptmodell ist eine Anleitung enthalten. Unter megaunboxed.com finden Sie weitere Bauanleitungen. / Istruzioni incluse solo per il modello principale. È possibile trovare le altre costruzioni su megaunboxed.com / Instructies alleen bij het hoofdmodel. Andere bouw mogelijkheden kunt u vinden op megaunboxed.com / Se incluyen las instrucciones para el modelo principal solamente. Se pueden encontrar otras construcciones en megaunboxed.com / Instruções incluídas somente para o modelo principal. Outras montagens podem ser encontradas em megaunboxed.com / Instruktioner medföljer endast för huvudmodellen. Andra byggen finns på megaunboxed.com / Ohjeet ovat sisällytetytjää vain päämalliinhin. Muut kokoonpanot ovat löydettävissä osoitteessa megaunboxed.com / Vejledning følger kun med hovedmodellen. Andre byggemodeller kan findes på megaunboxed.com / Instruksjoner kun inkludert for hovedmodell. Annen/andre versjon/-er finner du på megaunboxed.com / Załączono instrukcje tylko do głównego modelu. Inne wersje są dostępne na megaunboxed.com / Příbalené pokyny jsou pouze pro hlavní model. Ostatní stavby lze najít na megaunboxed.com / Pribalené pokyny sú iba hlavný model. Ostatné stavby možno nájsť na megaunboxed.com / A mellékelt utasítások csak a fő modellre vonatkoznak. Egyéb építõelem(ek) a megaunboxed.com weboldalon található(k) / Инструкция относится только к основной модели. Другие конструкции можно найти на сайте megaunboxed.com / Οι οδηγίες που περιλαμβάνονται είναι μόνο για το κύριο μοντέλο. Μπορείτε να βρείτε άλλες κατασκευές στο megaunboxed.com / Yönergeler sadece ana modeller için dahil edilmiştir. Diğer yapı parçaları megaunboxed.com adresinde bulunabilir megaunboxed.com / التعليمات موجودة للنموذج الرئيسي فقط. يمكن العثور على بناء (أنيبة) أخرى على موقع megaunboxed.com

BUILDING TOOL OUTIL DE CONSTRUCTION

HERRAMIENTA DE CONSTRUCCION
BAUWERKZEUG
FERRAMENTA DE MONTAJEM
ИНСТРУМЕНТ ДЛЯ КОНСТРУИРОВАНИЯ

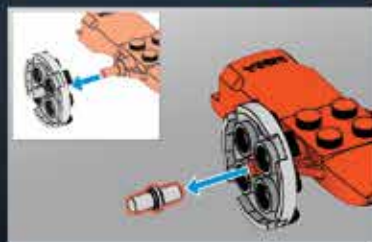
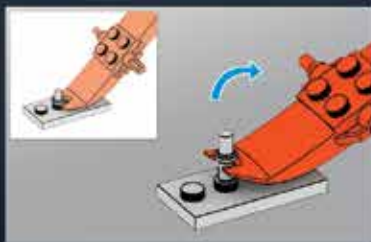
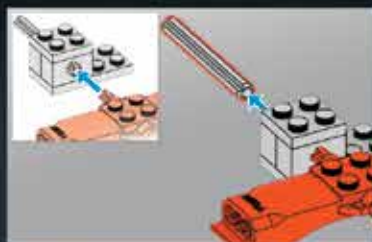
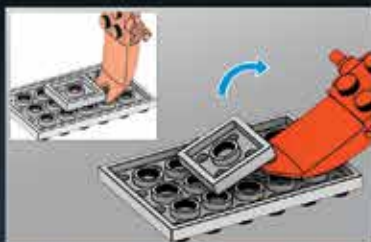

2

2x 1x2 Technic Technic
1x 1x8 Technic Technic
1x 1x4 Technic Technic
1x 1x8 Technic Technic

3

1x 1x2 Technic Technic
1x 1x4 Technic Technic
1x 1x4 Technic Technic
1x 1x4 Technic Technic
1x 1x4 Technic Technic

1 2 3

4



1X



4X

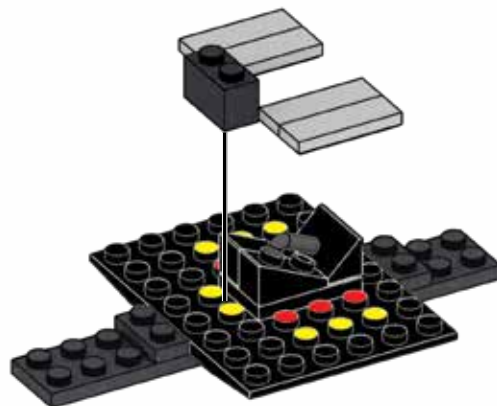

5



2X



Place temporary pieces.
Placer les pièces temporaires.
Colocar las piezas provisionales.
Colocar as peças provisórias.
Posizionare i pezzi provvisori.
Die vorübergehend benötigten Teile platzieren.
Umieścić tymczasowe elementy.
Plaats tijdelijke delen.
Поместите временные детали.
Placér midlertidige stykker.
Placera temporära delar.
Plasser midlertidige deler.
Aseta väliaikaiset osat.
Τοποθετήστε το προσωρινό κομμάτι.
Geçici parçaları yerleştirin.
Umístěte dočasné díly.
Vložte dočasné kusy.
Helyezze el az ideiglenes darabokat.
暫定ピースを配置してください

ضع القطع المؤقت

放置临时件

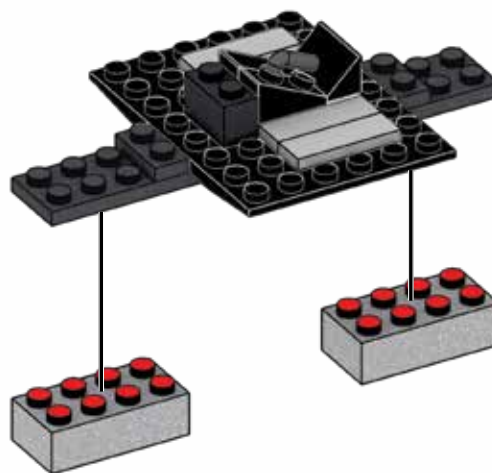

1



2

6



4X



8X



4X



2X



4X

x2



1



2

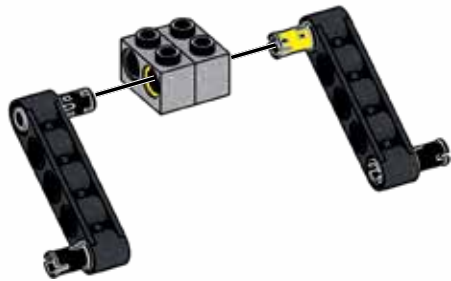

1



2



3

x2

7



4X



8



4X



1X



1X



1X

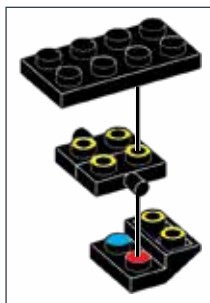

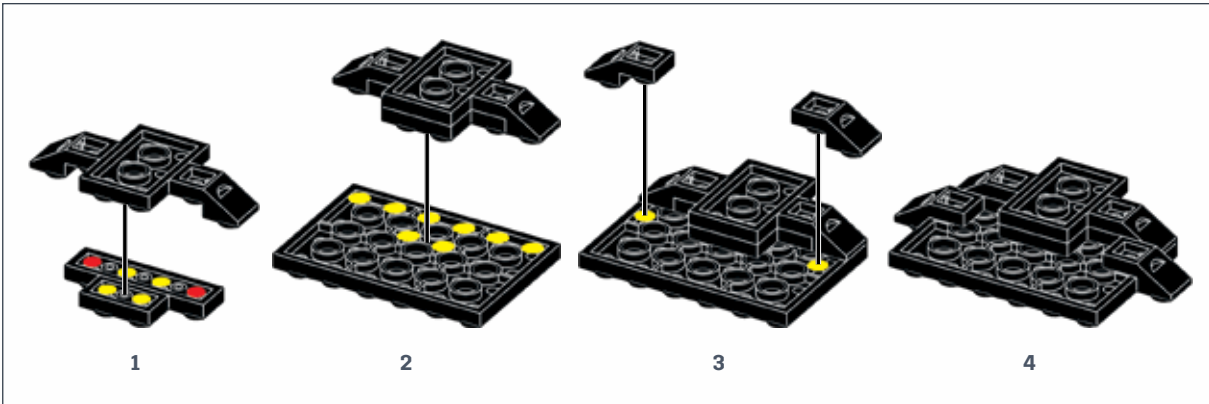
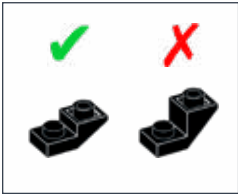

10



3X



2X



1X



1X

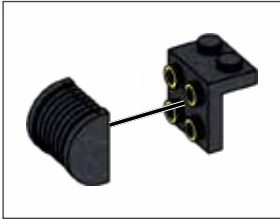

11

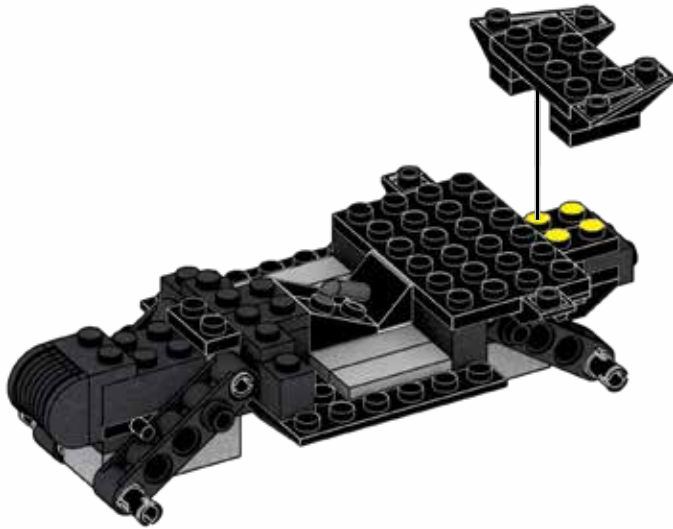
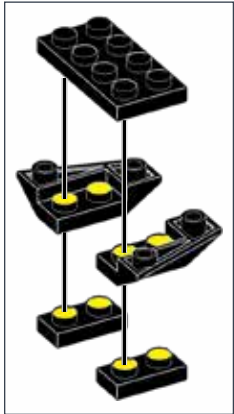

1

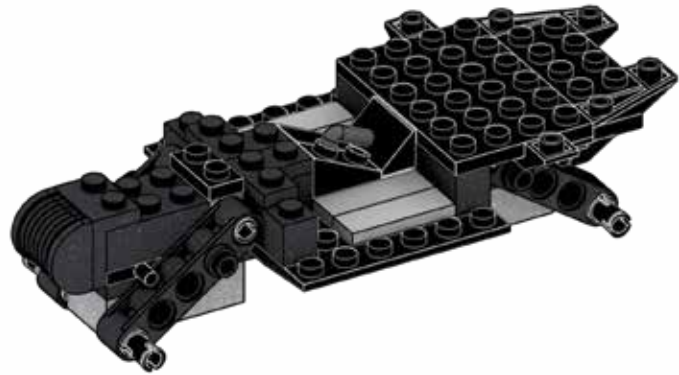

2

12



2X



2X



1X



1X



1X

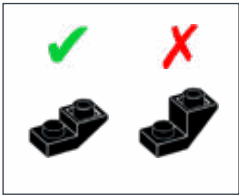
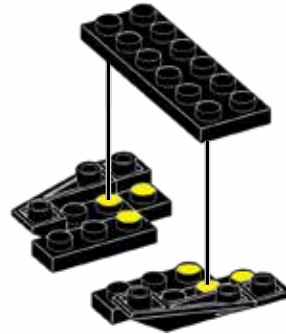

13



2X



2X



2X

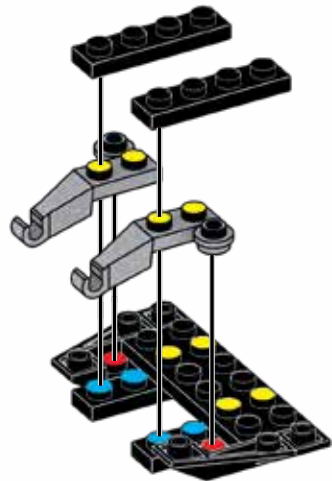

14



1X



1X



15



4X



2X



2X



2X



2X

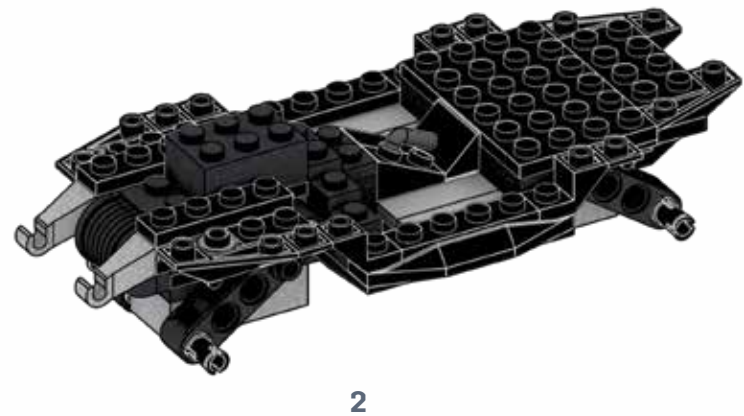
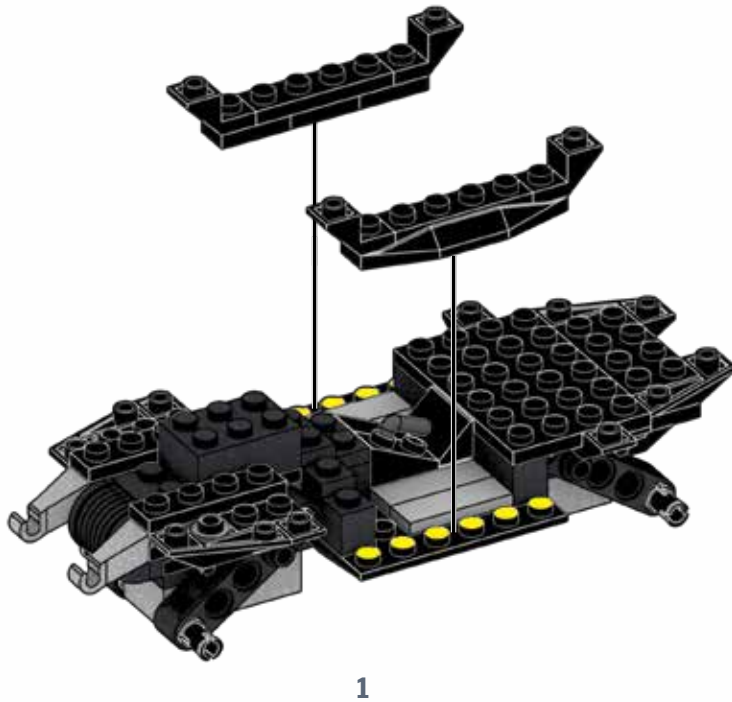
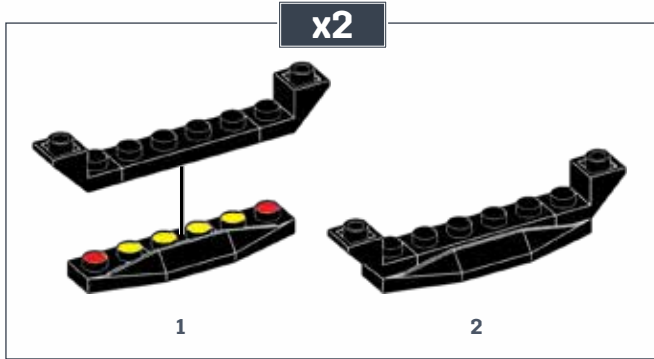
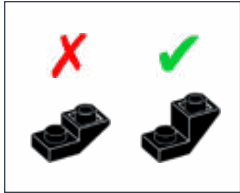



16



4X

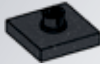

1X



1X



2X



1

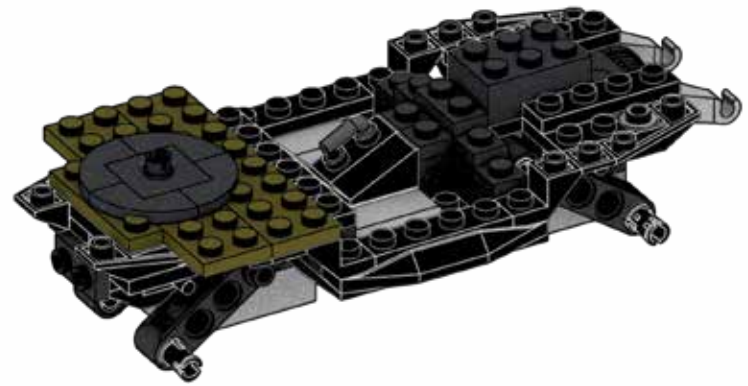

2

17

- 
2X
- 
2X
- 
1X
- 
1X
- 
2X

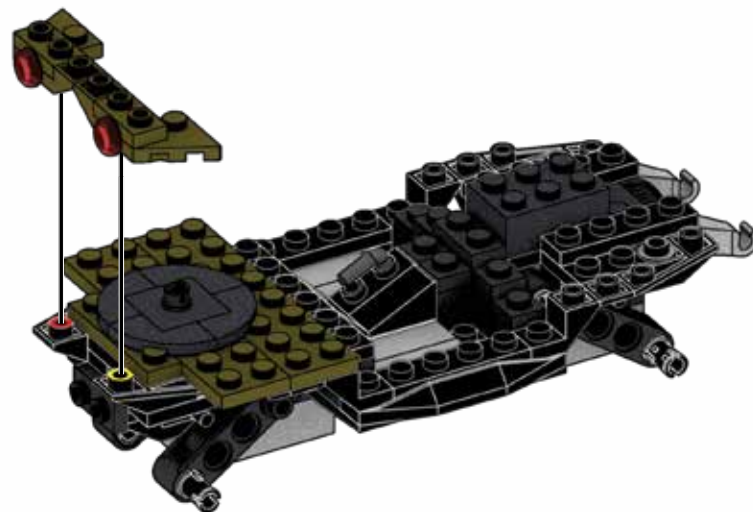
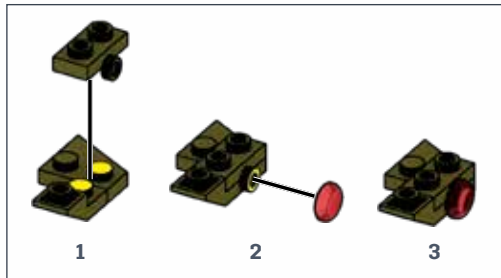
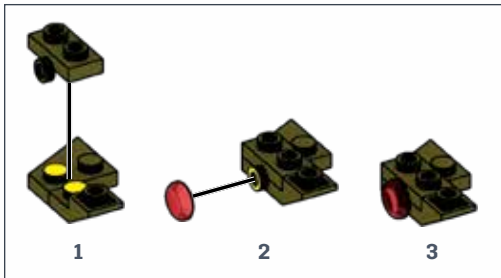

18

- 
1X
- 
1X
- 
1X
- 
1X
- 
1X



19



1X



1X



1X

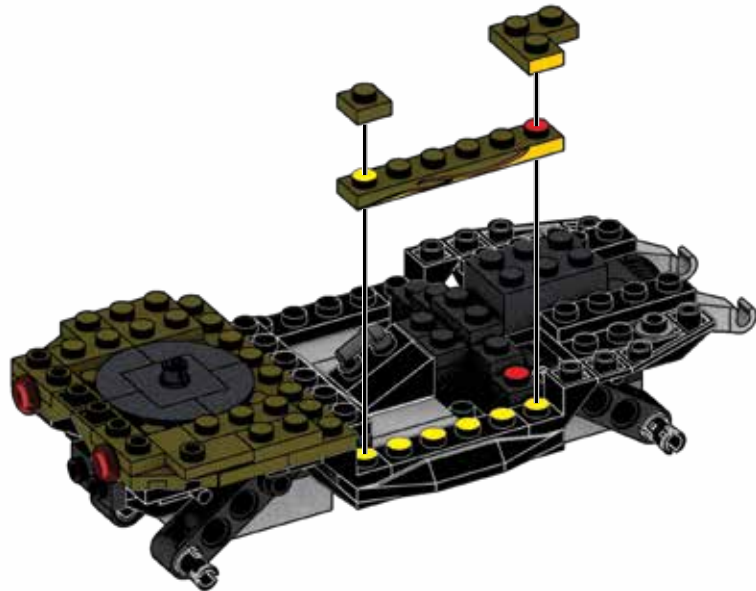

20



1X



1X



1X



1X

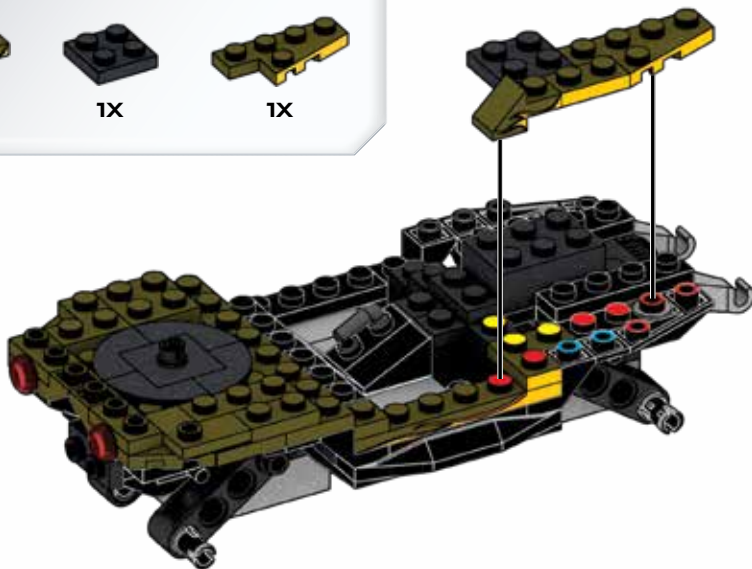

1



2

21

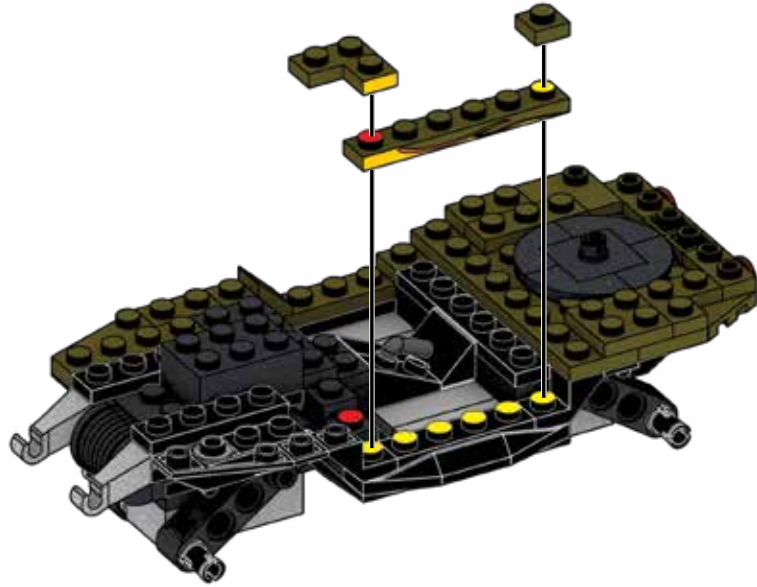

22

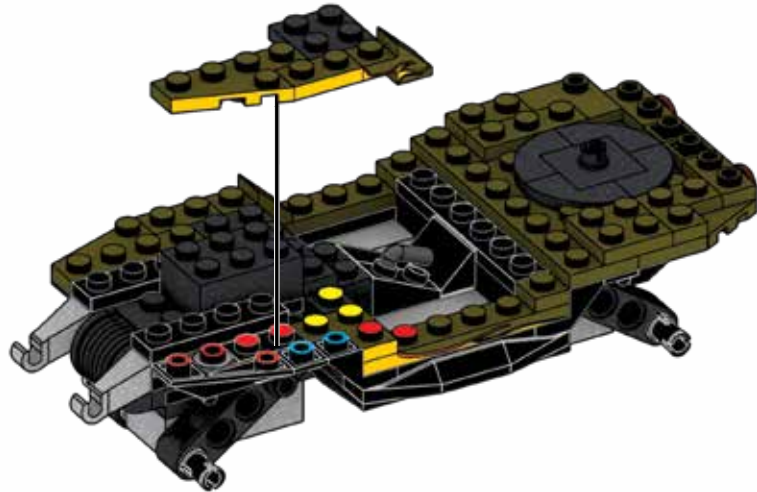

23



1X

2X

2X

1X

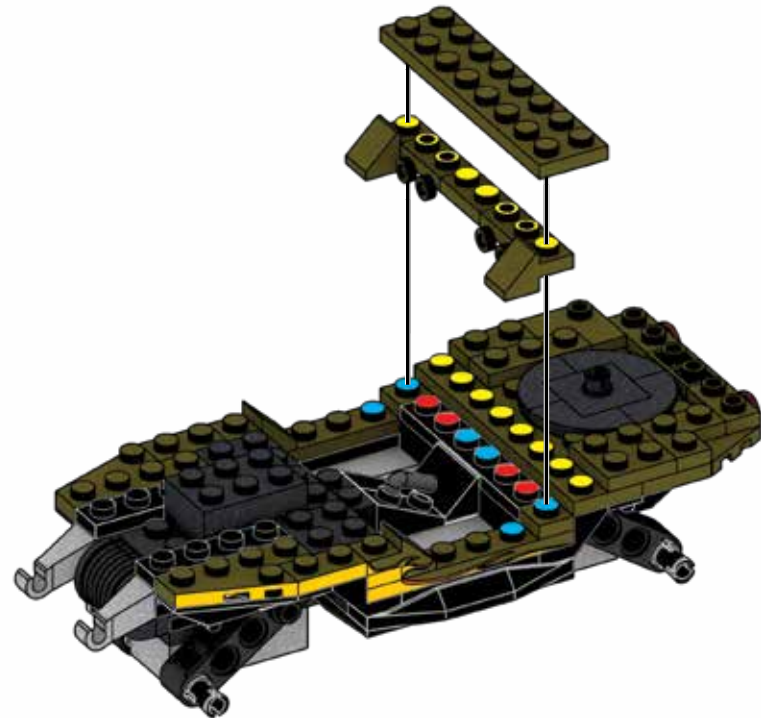

24

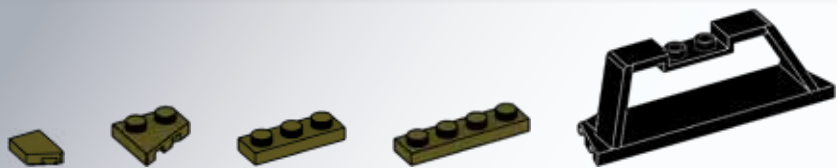

1X

1X

1X

2X

1X



25

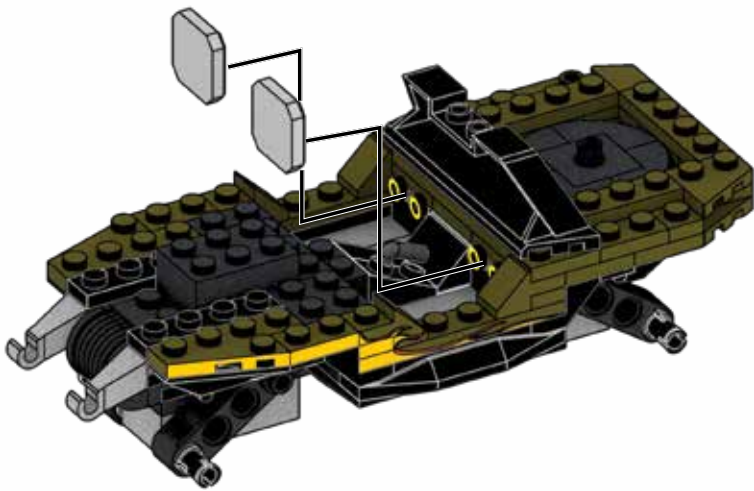

26

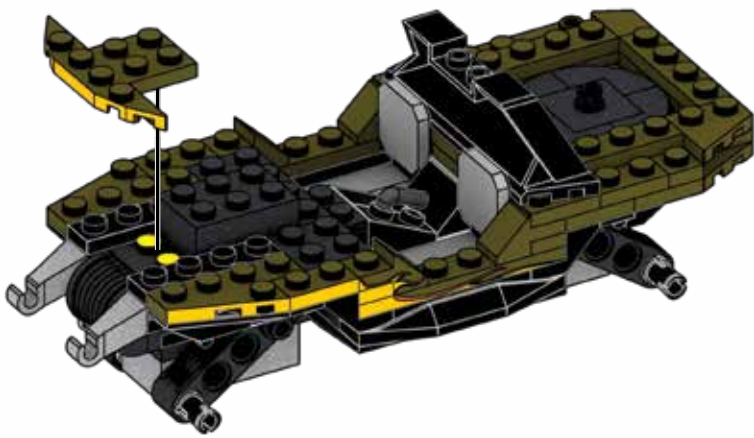

27



2X



2X



2X

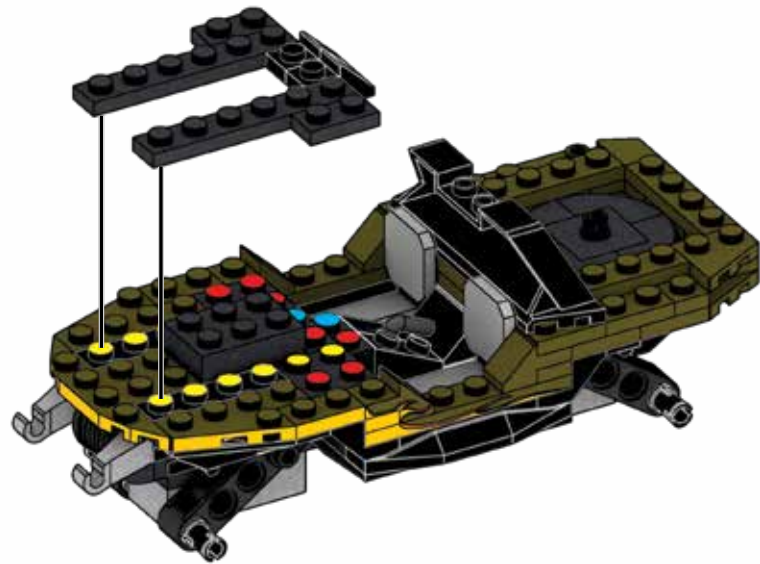

28



1X



2X



1X



1X



1X

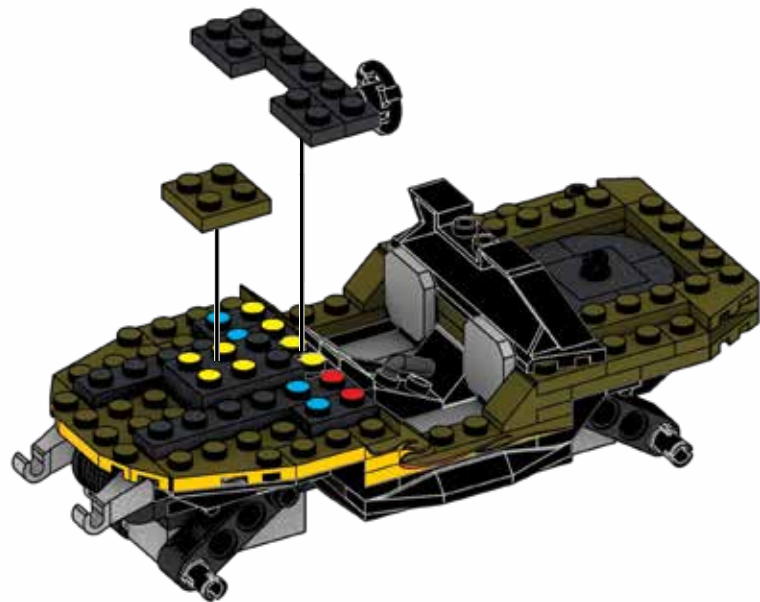
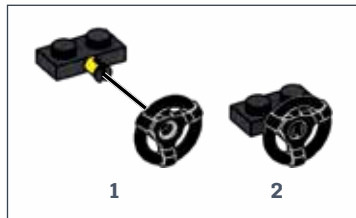



29



1X



1X



1X



1X

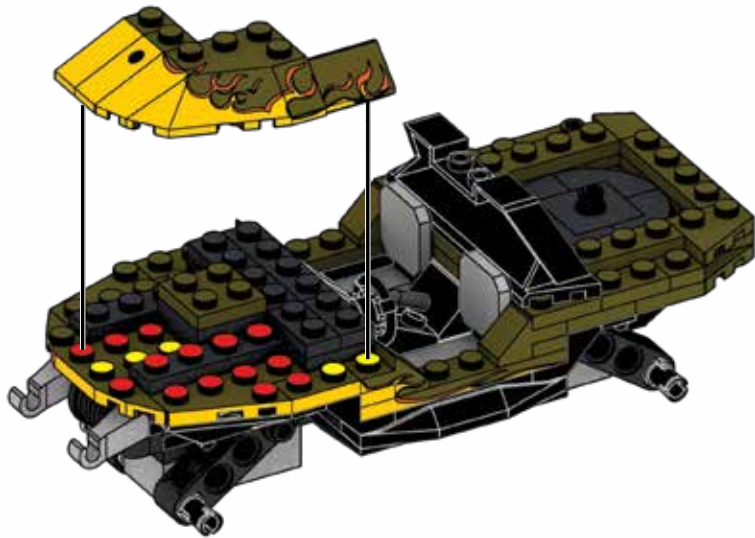

1

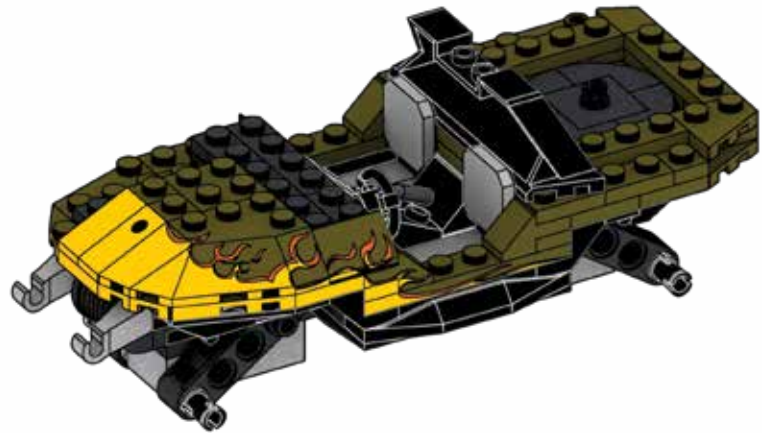

2



1X



1X



1X



31

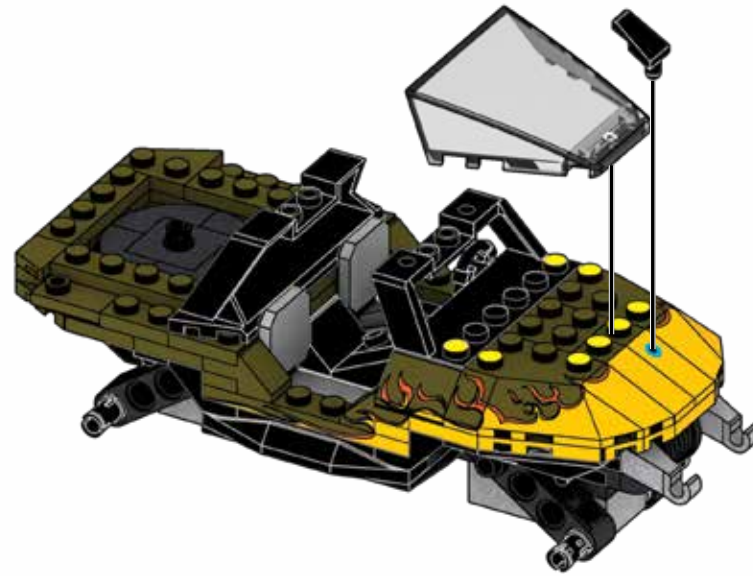
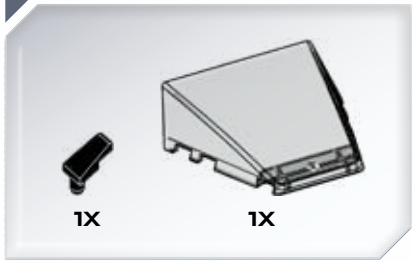

32

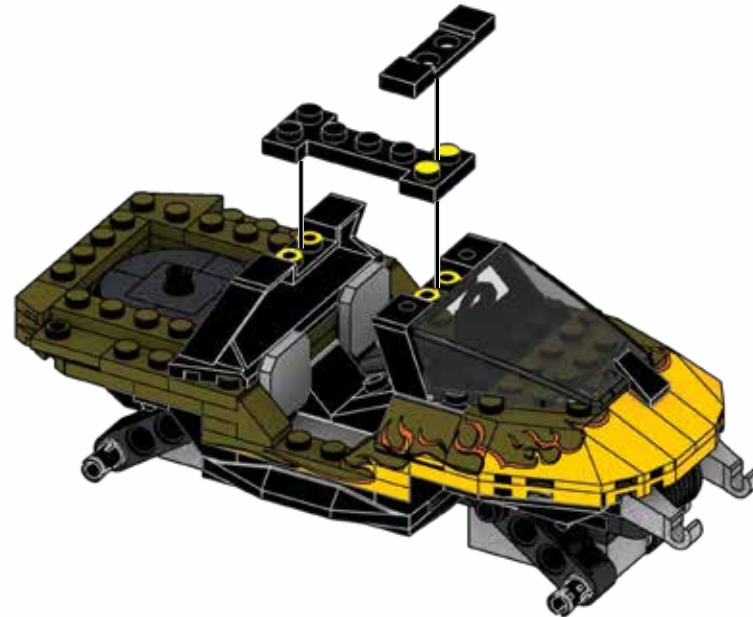
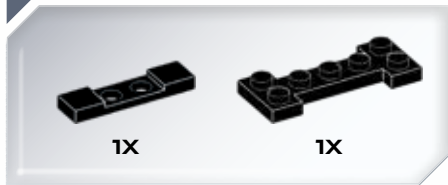

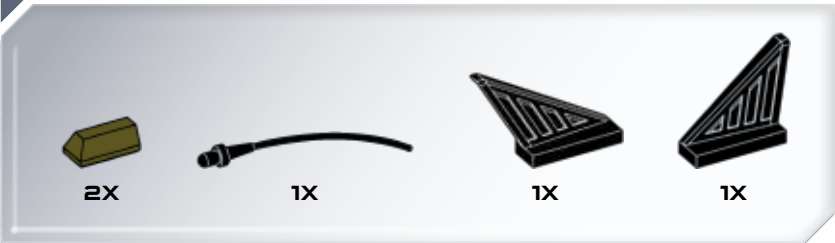

1



2

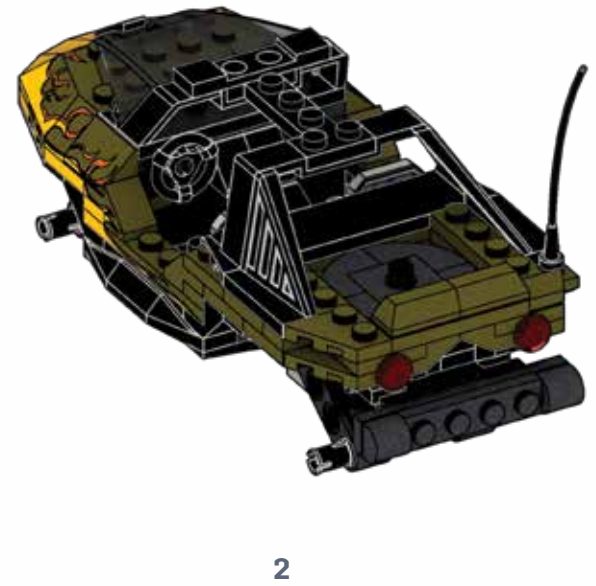
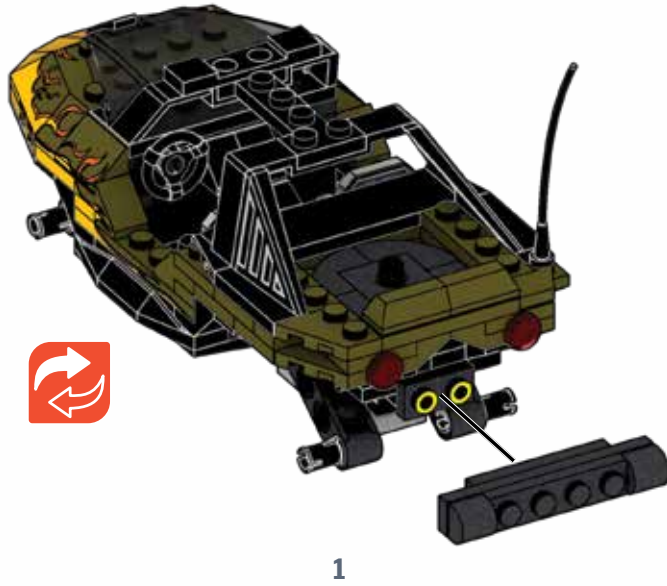
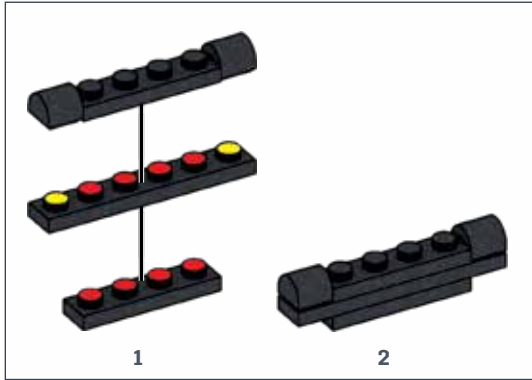

35



36

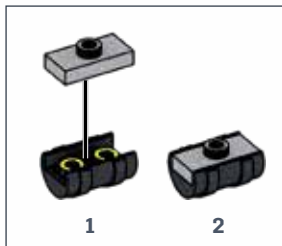
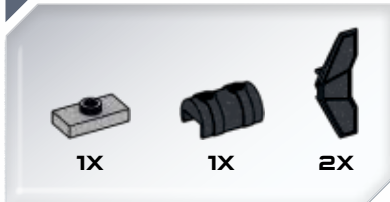

37

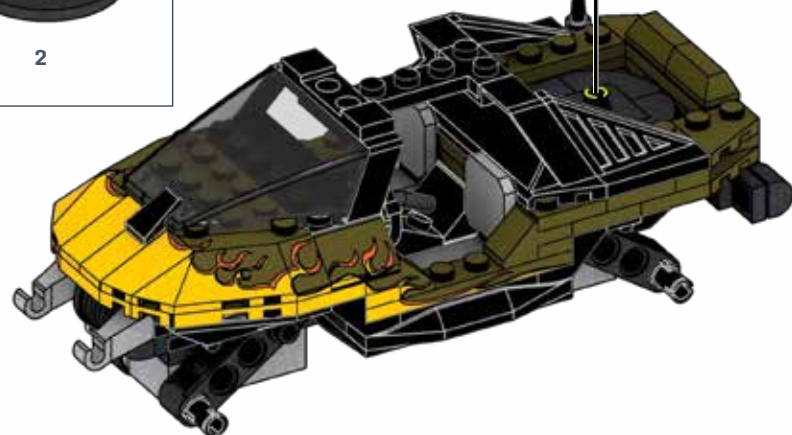
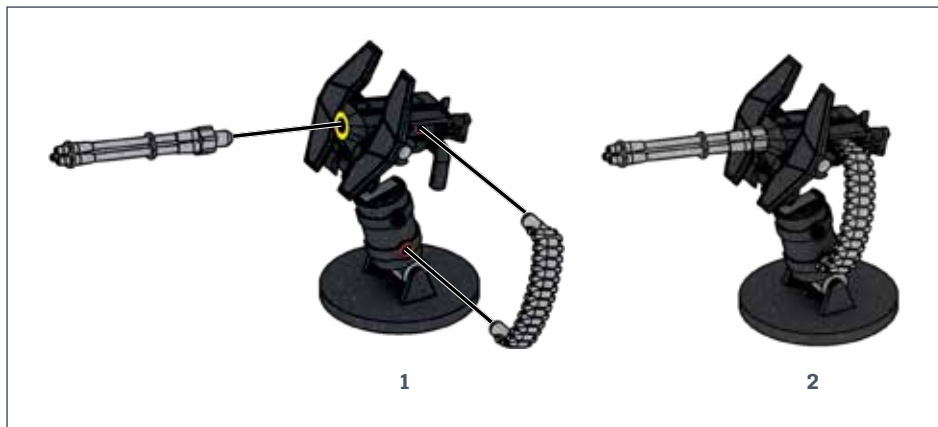



Remove temporary pieces.
 Retirer les pièces temporaires.
 Retirar las piezas provisionales.
 Remover as peças temporárias.
 Rimuovere i pezzi provvisori.
 Die vorübergehend benötigten Teile entfernen.
 Usunač elementy tymczasowe.
 Verwijder tijdelijke delen.
 Удалите временные детали.
 Fjern midlertidige stykker.
 Ta bort temporära delar.
 Fjern midlertidige deler.
 Poista väliaikaiset osat.
 Αφαιρέστε τα προσωρινά κομμάτια.
 Geçici parçaları çıkarın.
 Odstraňte dočasné diely.
 Vyberte dočasné kusy.
 Távolítsa el az ideiglenes darabokat.
 暫定ピースを外してください

انزع القطع المؤقتة

移除临时件



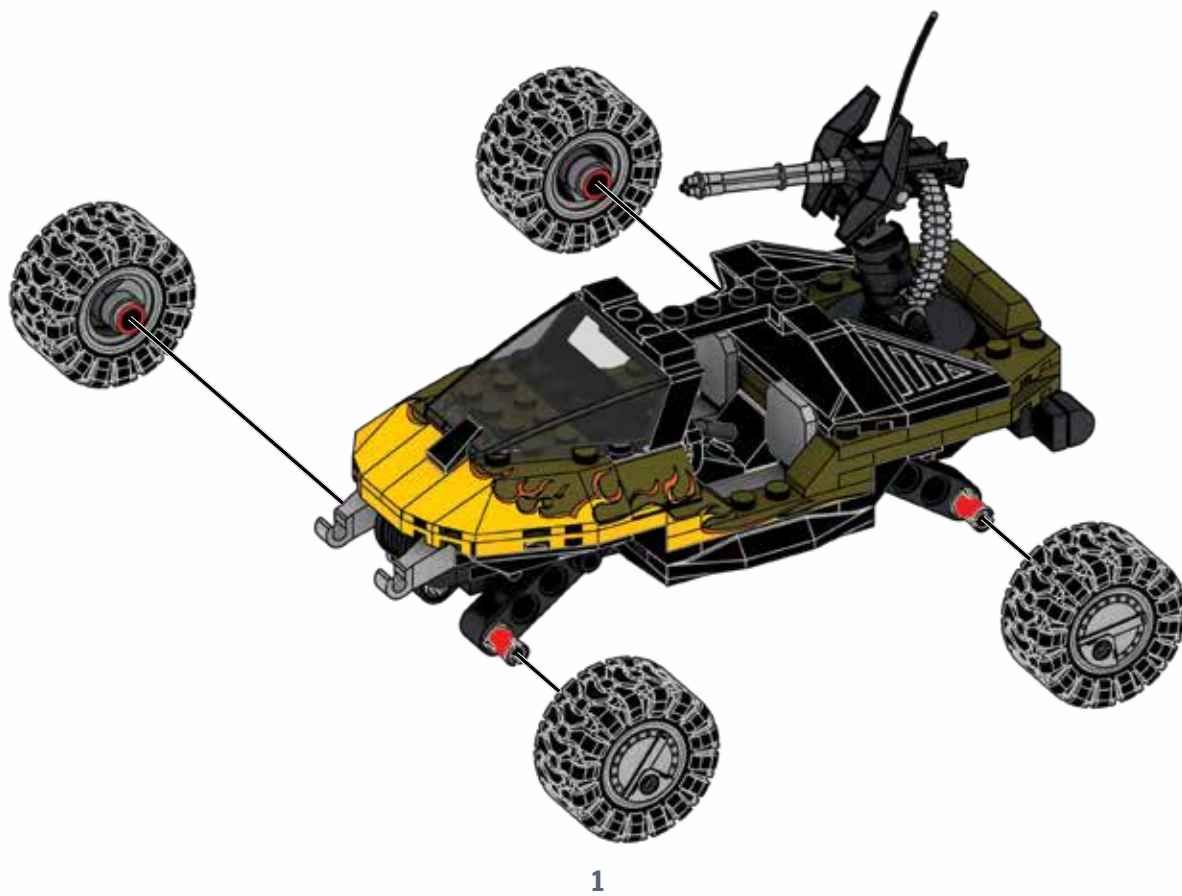
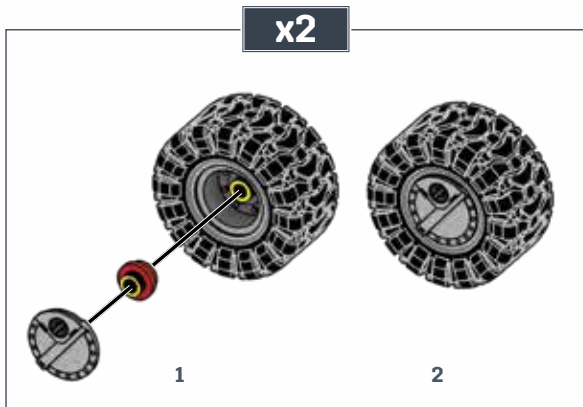
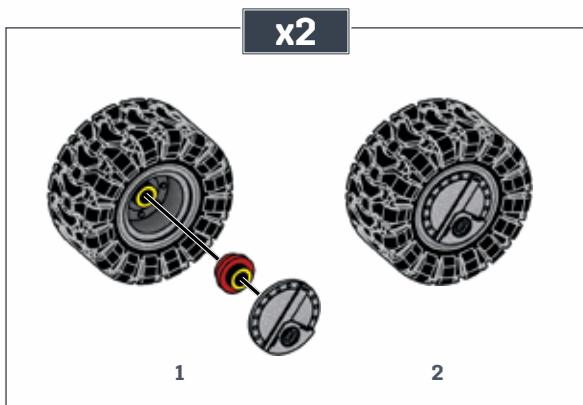



2

40



1



2

41



1



2



3

42

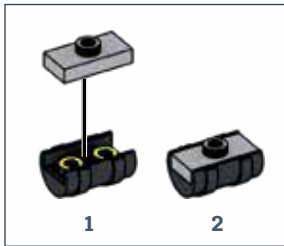

1



2

43



1

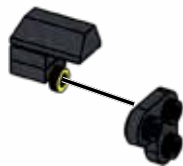

2

44

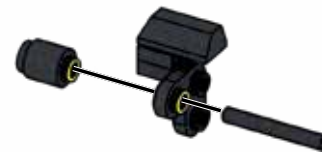

1



2

45



46

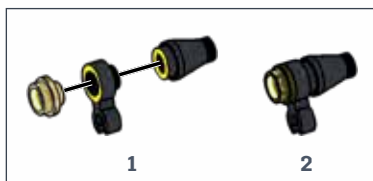

1



2



47



5X



1X



1X

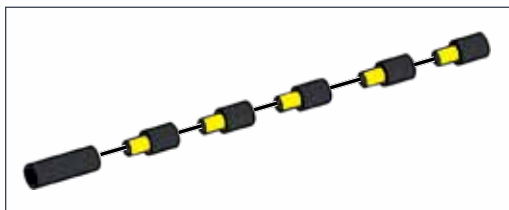

48



1X



1X



1X



1X



1

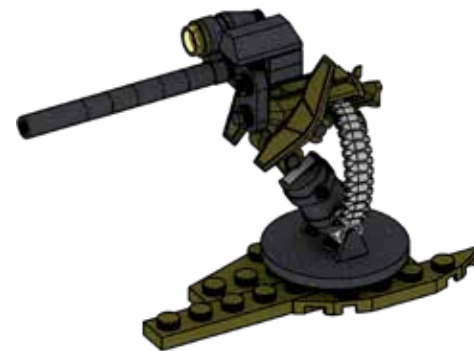

2

49

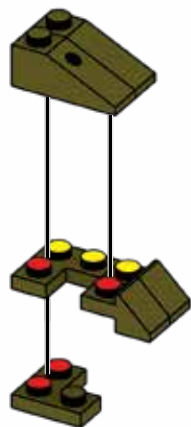
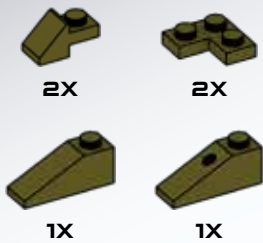

50

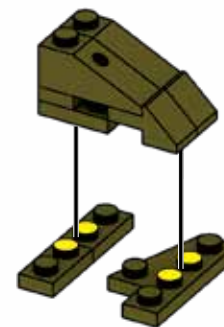

51

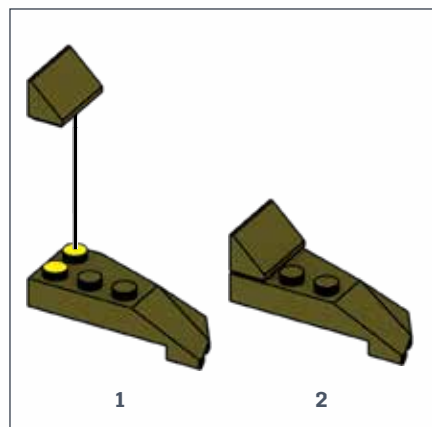
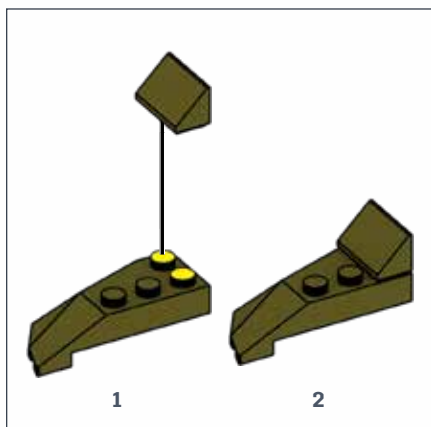

52

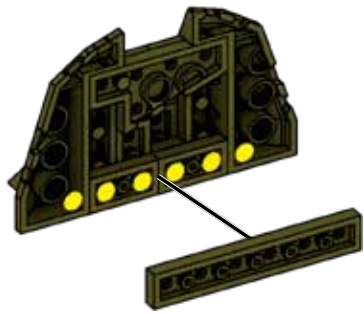
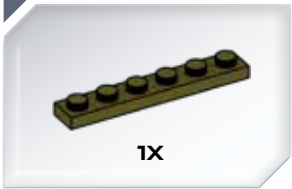

1



2



3



SPARTAN DOUGLAS-042



SPARTAN JEROME-092



SERINA



SPARTAN ALICE-130

Red Team Warthog Rescue / Red Team et la Mission de Sauvetage du Warthog

Red Team Warthog Fahrzeug / Warthog Missione di Soccorso Squadra Rossa / Rood Team Wrattenzwijnredding / Warthog de rescate del Equipo Rojo
 Warthog de resgate da Equipe Vermelha / Red Team Warthog-redningsaktion / Guziec – Misja ratunkowa Drużyny Czerwonych / Červený tím Warthog Rescue
 Piros csapat – Warthog mentőküldetés / Набор “Спасательная миссия красной команды на Вепре” / Κόκκινη Ομάδα -Όχημα Διάσωσης
 Kırmızı Takım Warthog Kurtarma Görevi / ذاقنإلإا ءمم قنكئرم Red Team Warthog Rescue

2X AM75332X
 1X AM01113ZD
 2X AM18560APG
 4X AM18560AMC
 5X AM74397MM
 4X AM19158MM
 2X AM03328AXU
 1X AM03328MM
 1X AM77574MM
 2X AM16980MM
 1X AM74300AXU
 1X AM18240F
 1X AM12251MM
 2X AM17003APG

3X AM17003MM
 1X AM19392BDG
 1X AM17506MM
 8X AM72534F
 1X AM81215MM
 1X AM80144MM
 1X AM81383F
 4X AM78863APG
 2X AM18287MM
 1X AM18260APG
 1X AM18260JZ
 6X AM72002F
 2X AM72002AXU
 4X AM17522F

1X AS-HHC38-05
 1X AS-HHC38-06
 4X AM18740AXU
 2X AM18740F
 2X AM18232AXU
 1X AM18232MM
 2X AM07590APG
 6X AM09393F
 7X AM09393MM
 2X AS-HHC38-10
 4X AM09393AXU
 2X AM15480F
 2X AM15481F
 2X AM09835F

2X AM78926AXU
 1X AM18221MM
 4X AM79563F
 2X AM76467AXU
 1X AM18014MM
 2X AM18666AXU
 1X AM18665AXU
 1X AM03019F
 2X AM03019AXU
 1X AS-HHC38-02
 1X AS-HHC38-04
 1X AM04430F
 1X AM04429F

1X AM09106MM
 5X AM09013MM
 4X AM79878APG
 2X AM18255MM
 4X AM18667MM
 1X AM16972MM
 1X AM74428AXU
 3X AM15484AXU
 2X AM15484MM
 1X AS-HHC38-11
 1X AS-HHC38-12

2X AM18543BLG
 1X AM73009APG
 2X AM81262MM
 2X AM03773AXU
 2X AM03773MM
 1X AM18223F
 1X AM17019MM
 1X AM09023APG
 1X AM79355MM
 2X AM18256MM
 4X AM80966BLG

2X AM01314F
 2X AM01314AXU
 1X AM16978AXU
 2X AM18254APG
 1X AM16636AXU
 2X AM16636MM
 1X AM01323AXU
 1X AS-HHC38-15
 1X AS-HHC38-16
 1X AM18231AXU
 2X AM16964APG

2X AM18224F
 2X AM18225F
 2X AM03772F
 2X AM03873MM
 3X AM09593AXU
 5X AM09593F
 3X AM09593MM
 1X AM17020F
 1X AS-HHC38-13
 1X AS-HHC38-14
 1X AM09487AXU
 1X AM09488AXU
 2X AM09033APG

1X AM18253MM
 1X AM18253AXU
 2X AM09493F
 1X AM18158APG
 2X X-HHC38-01F
 1X AM17148F
 1X AS-HHC38-07
 1X AS-HHC38-08
 3X AM09292MM
 2X AM09292AXU
 3X AM76357F
 1X AS-HHC38-09
 1X AM18233AXU

2X AS-HHC38-18
 2X AS-HHC38-19
 2X AM81466MM
 1X AM18238F
 1X AM18239F
 1X AS-HHC38-03
 1X AM18227AXU
 1X AS-HHC38-01
 1X AM18226AXU
 1X AM80965MM

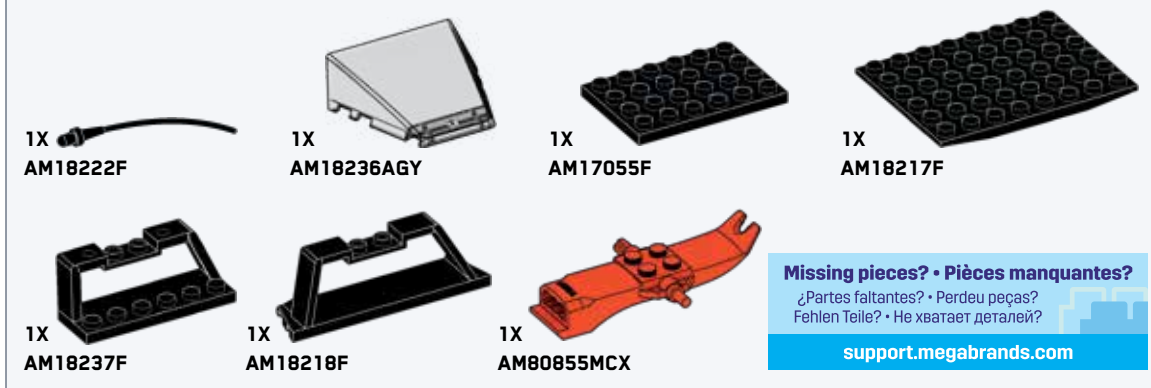
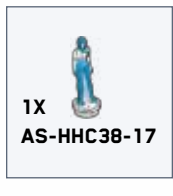
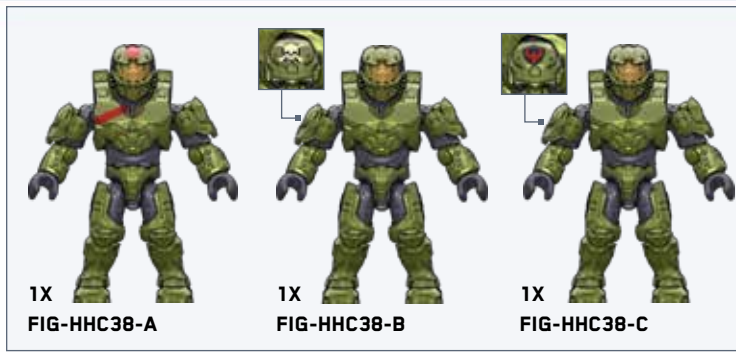

Missing pieces? • Pièces manquantes?
 ¿Partes faltantes? • Perdeu peças?
 Fehlern Teile? • Не хватает деталей?
support.megabrand.com

*HHC30 / HHC31 / HHC32 / HHC33 / HHC34 / HHC36 / HDH92 / HDP62 / HHC44 / Set(s) sold separately and subject to availability. / Ensemble(s) vendu(s) séparément. Certains produits peuvent ne pas être commercialisés. / Se vende(n) por separado y está(n) sujeto(s) a disponibilidad. / Conjunto(s) vendido(s) em separado e sujeito(s) à disponibilidade. / Set in vendita separatamente, secondo disponibilità. / Das/Die Set(s) sind separat erhältlich. / Zestaw(ły) sprzedawany(e) oddzielnie w zależności od dostępności. / Set(s) apart verkrijgbaar en afhankelijk van beschikbaarheid. / Набор(-ы) продаются отдельно, при наличии. / Sæt sælges separat og så længe lager haves. / Seten säljs separat så länge lagret räcker. / Settet/settene selges separat så langt lageret rekker. / Pakkaus/pakkaukset myydään erikseen, saatavuus voi vaihdella. / Το(α) σετ πωλούνται ξεχωριστά και ανάλογα με τη διαθεσιμότητα. / Setler ayrı olarak satılır ve stoklarla sınırlıdır. / Set (sety) se prodává (prodávají) samostatně dle aktuální nabídky. / Súprava/-y sa predáva(jú) samostatne a podľa dostupnosti. / A készlet(ek) külön kapható(k), az elérhetőség változhat. / セット商品は別売りになります。在庫状況は別途ご確認お願いします。 / تباع المجموعة أو المجموعات على حدة وتخضع لتوافرها.

每套单独发售，按供货情况决定。

Mattel Europa B.V., Gonderl 1, 1186 MJ Amstelveen, Nederland. Mattel U.K. Limited, The Porter Building, Slough SL1 1FQ, UK. Mattel France, Parc de la Cerisaie, 1/3/5 allée des Fleurs, 94260 Fresnes Cedex. N° Cristal 0969 36 99 99 (Numéro non surtaxé) ou www.lesjouetsmattel.fr Mattel Belgium, Trade Mart, Atomiumsquare, Bogota 202 - B 275, 1020 Brussels. Gratis nummer België: 0800 - 16 936 - Gratis nummer Luxemburg: 800 - 22 784 - Gratis nummer Nederland: 0800 - 262 88 35. Deutschland: Mattel GmbH, Solmsstraße 4, D-60486 Frankfurt am Main. Schweiz: Mattel AG, Kirchstrasse 24, CH-3097 Liebefeld. Österreich: Mattel Ges.m.b.H., Campus 21, Liebermannstraße A01 404, A- 2345 Brunn/Gebrige. Mattel Italy Srl, Via Bracco, 6-MAC 6, 20159 Milano, Italy. Servizio assistenza clienti: Customersrvitalia@mattel.com - Numero verde 800 11 37 11. Mattel España, S.A., Aribau 200. 08036 Barcelona. c.service.spain@mattel.com Tel: 900 102 390 http://www.service.mattel.com/es. Mattel East Asia Ltd., Room 503-09, North Tower, World Finance Centre, Harbour City, Tsimshatsui, HK, China. Tel: (852) 3185-6500. Diimport & Diedarkan Oleh: Mattel Continental Asia Sdn Bhd. Level 19, Tower 3, Avenue 7, No. 8 Jalan Kerinci, Bangsar South, 59200 Kuala Lumpur, Malaysia. Mattel South Africa (PTY) LTD, Office 102 I3, 30 Melrose Boulevard, Johannesburg 2196. Dystrybutor: Mattel Poland Sp. z o.o., Warsaw Trade Tower 34 p., ul. Chłodna 51, 00-867 Warszawa. Mattel Australia Pty. Ltd., 658 Church St., Richmond, Victoria, 3121. Consumer Advisory Service - 1300 135 312. Mattel AEBE, Εθνόρου Μοκάρου 1, Κτήριο Κ-2, ΤΚ 17561, Πλατιά Ούλγπο. Mattel Oyuncakçılık Tic. Ltd. Şti. İçerenköy Mah., Erkut Sok. A Blok No:12 Üner Plaza Kat:9-10 34752 Ataşehir İstanbul. Tel: 0216 570 75 00. Импортёр/Уполномоченная организация: ООО "МАТТЕЛ" Российская Федерация, 105120 Москва, 2-й Сыромятинский переулок, 1; +7 495 287 79 39. Mattel Czech Republic s.r.o., The Forum, Václavské nám. 19, 11000 Praha1. Mattel, 333 Continental Boulevard, El Segundo, CA 90245, USA. Mattel Canada Inc., Mississauga, Ontario L5R 3W2. Consumer Services: You may call us free at/ Composez sans frais le 1-800-524-8697. Importado y distribuido por Mattel de México, S.A. de C.V., Miguel de Cervantes Saavedra No. 193, Pisos 10 y 11, Col. Granada, Alcañidia Miguel Hidalgo, C.P. 11520, México, Ciudad de México. R.F.C. MME-920701-NB3. Tels: 59-05-51-00-Ext. 5206 ó 01-800-463-59-89. Mattel Chile, S.A., Avenida Américo Vespucio 501-B, Quilicura, Santiago. Tel: 1230-020-6213. Servicio al consumidor Venezuela: Tel: 0-800-100-9123. Mattel Argentina, S.A., Av. Libertador 1000, Piso 11 - Oficinas 109 y 111, Vicente López - Prov. Buenos Aires. Tel: 0800-666-3373. Mattel Colombia, S.A., Calle 12347-07 P5, Bogotá. Tel: 01-800-710-2069. Mattel Perú, S.A., Av. Juan de Arona # 151, Centro Empresarial Juan de Arona, Torre C, Piso 7, Oficina 704, San Isidro, Lima 27, Perú. RUC: 20425853865. Reg. Importador: 02350-12-JUE-DIGESA. Tel: 0800-54744. E-mail Latinoamérica: servicio.clientes@mattel.com. Mattel do Brasil Ltda. - CNPJ: 54.558.002/0001-20 - Rua Verbo Divino, 1488 - 2º - Andar - 04719-904 - Chácara Santo Antônio - São Paulo - SP - Brasil. Serviço de Atendimento ao Consumidor: fone 0800 575 0780. E-mail: sac.matteldobrazil@mattel.com

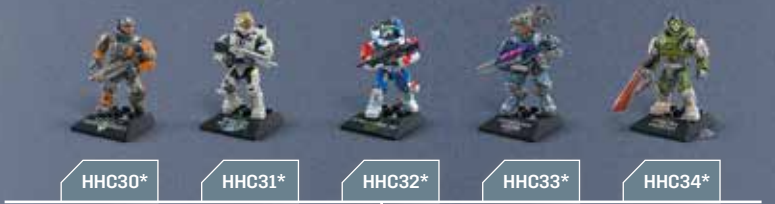

BUILD A BIGGER UNIVERSE

CONSTRUISEZ UN MONDE TOUJOURS PLUS GRAND



CONSTRUYE UN UNIVERSO MÁS GRANDE • CONSTRUA UM UNIVERSO MAIOR
BAUE EIN GRÖßERES UNIVERSUM • ПОСТРОЙТЕ БОЛЬШУЮ ВСЕЛЕННУЮ

Mattel Canada Inc. Mississauga, Ontario L5R 3W2.
MADE IN CHINA. FABRIQUÉ EN CHINE. FABRICADO NA / HECHO EN CHINA.
ИЗГОТОВЛЕНО В КИТАЕ. ÇIN'DE ÜRETİLMİŞTİR. صنع في الصين

© 2021 MEGA Brands &™ MEGA Brands.
Printed in China / Imprimé en Chine

AD-HHC38-01



© 2021 Microsoft Corporation. All Rights Reserved. Microsoft, Halo, the Halo logo, Xbox, the Xbox logo, and 343 Industries are trademarks of the Microsoft group of companies.



1186 MJ, 1, NL

© D714,887, D781,964, D797,203

