

MEGA

POKÉMON

BUILD YOUR PIXEL ART

CONSTRUIS TON ART PIXEL

**CONSTRUYE TU ARTE DE PÍXEL
CRIE SUA ARTE EM PÍXEL**



**BULBASUR
BULBIZARRE
BISASAM**

HTH75



BUILD YOUR PIXEL ART

Officially licensed Pokémon Pixel Art lets you build lasting memories with some of your favorite Pokémon.

CONSTRUIS TON ART PIXEL

Le Pokémon Pixel Art sous licence officielle vous permet de construire des souvenirs inoubliables avec certains de vos Pokémon préférés.

CONSTRUYE TU ARTE DE PÍXEL

Pokémon Pixel Art, oficialmente certificada, les permite crear recuerdos perdurables con algunos de sus Pokémon favoritos.

CRIE SUA ARTE EM PIXAEL

A linha Pokémon Pixel Art oficialmente licenciada te deixa criar memórias duradouras com alguns de seus Pokémons favoritos.

PIXELBILDER ERSTELLEN

Mit offiziell lizenziertes Pokémon Pixelkunst bleibende Erinnerungen an Lieblings-Pokémons gestalten.

СОБЕРИ СВОЮ ПИКСЕЛЬНУЮ ФИГУРКУ

С лицензионной версией Pokémon Pixel Art вы сможете создать незабываемые моменты с вашим любимым Pokémon.



Set(s) sold separately and subject to availability. / Ensemble(s) vendu(s) séparément. Certains produits peuvent ne pas être commercialisés. / Se vende(n) por separado y está(n) sujeto(s) a disponibilidad. / Conjunto(s) vendido(s) em separado e sujeito(s) à disponibilidade. / Set in vendita separatamente, secondo disponibilità. / Das/Die Set(s) sind separat erhältlich. / Zestaw(y) sprzedawany(e) oddzielnie w zależności od dostępności. / Set(s) apart verkrijgbaar en afhankelijk van beschikbaarheid. / Набор(ы) продаются отдельно, при наличии. / Sæt sælges separat og så længe lager haves. / Seten säljs separat så länge lagret räcker. / Settet/settene selges separat så langt lagret rekker. / Pakkaus/pakkaukset myydään erikseen, saatavuus voi vaihdella. / Το(α) σετ πωλούνται ξεχωριστά και ανάλογα με τη διαθεσιμότητα. / Setler ayrı olarak satılır ve stoklarla sınırlıdır. / Set (sety) se prodává (prodávají) samostatně dle aktuální nabídky. / Súprrava/-y sa predáva (jú) samostatne a podľa dostupnosti. / A készlet(ek) külön kapható(k), az elérhetőség változhat. / セット商品は別売りになります。在庫状況は別途ご確認お願いします。 / تباع المجموعة أو المجموعات على حدة وتوضع لتوافرها. / 每套单独发售，按供货情况决定。

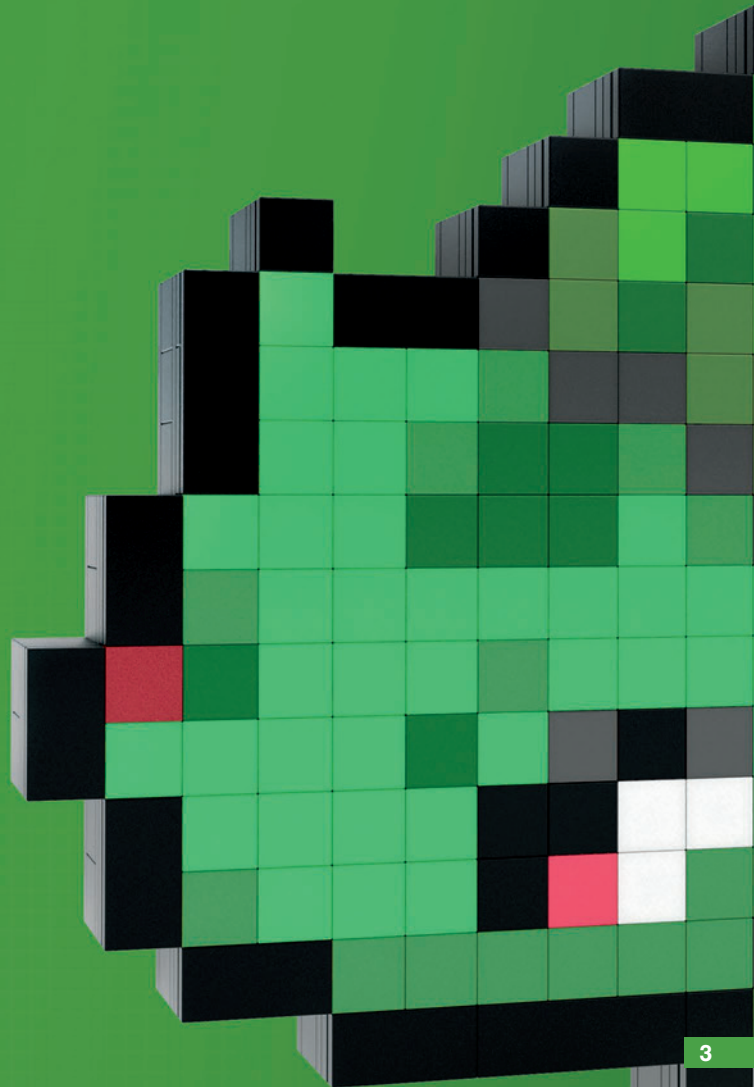
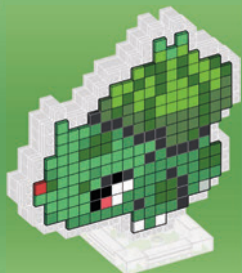
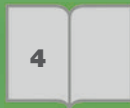
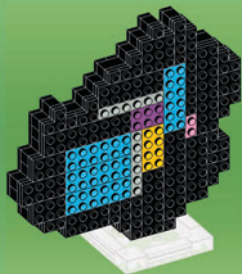



**GET INSTRUCTIONS ONLINE
INSTRUCTIONS DISPONIBLES
EN LIGNE**

CONSULTA LAS INSTRUCCIONES EN LÍNEA
OBTEN INSTRUÇÕES ONLINE
ANWEISUNGEN ONLINE ERHÄLTICH
ИНСТРУКЦИИ ДОСТУПНЫ ОНЛАЙН

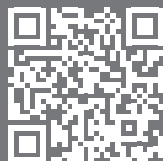

megaunboxed.com

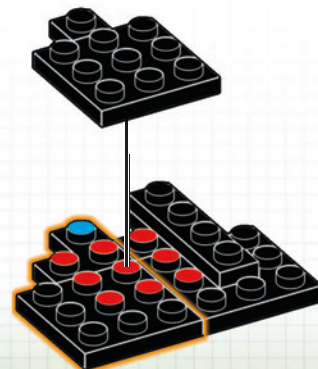
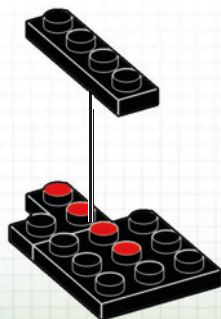
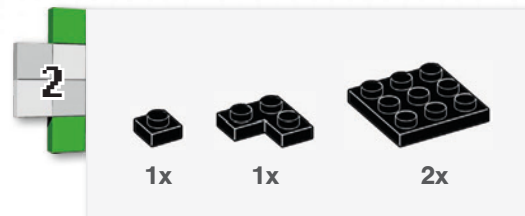
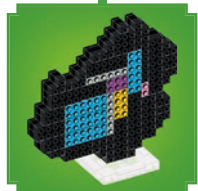

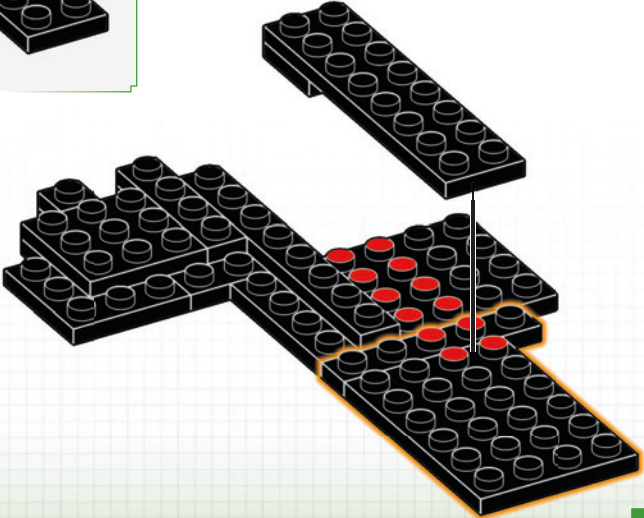
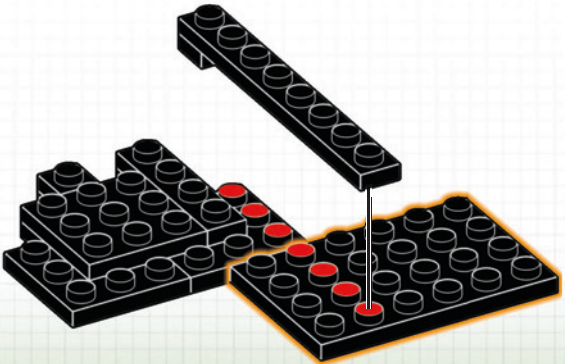
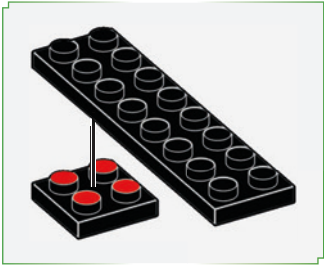
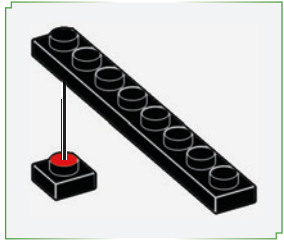
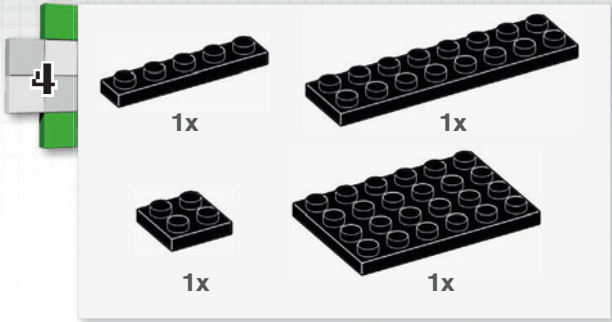
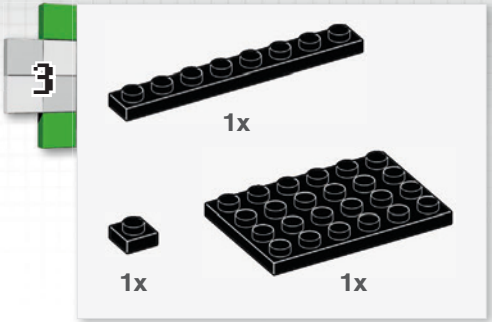

5



2x



3x



2x



1



2

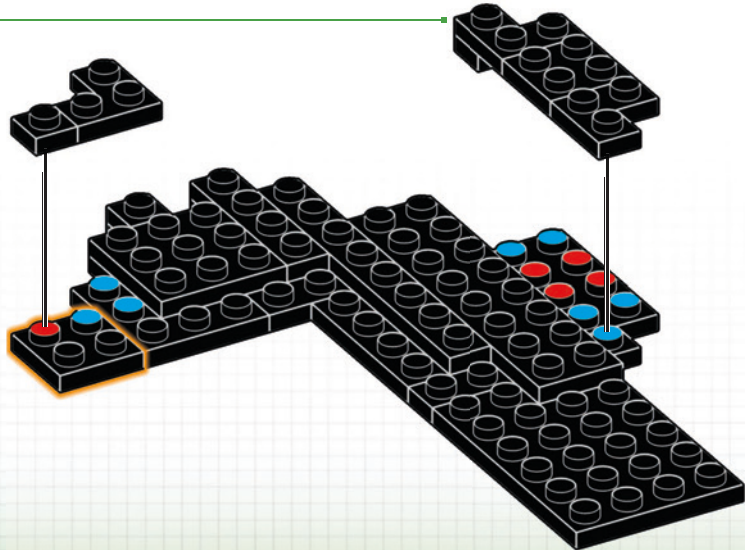

6



1x



1x



1x

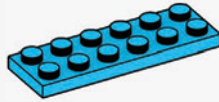

1x

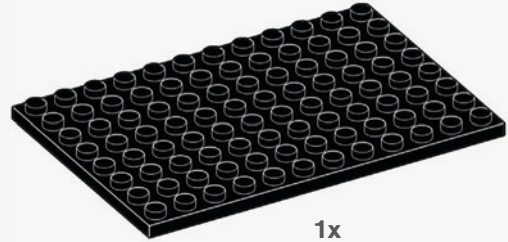

1x

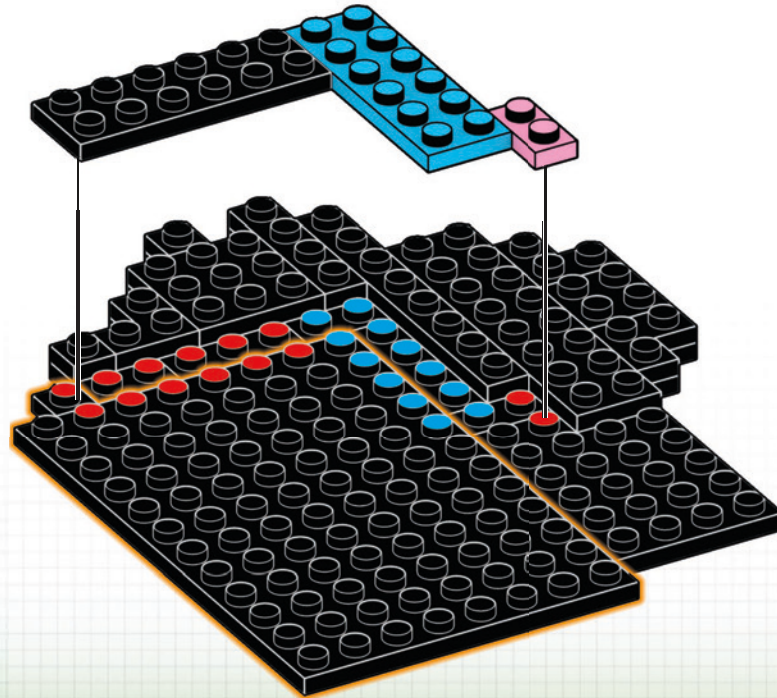

7



2x



2x



1x



1x

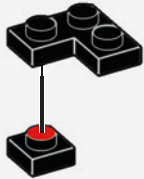

1



2

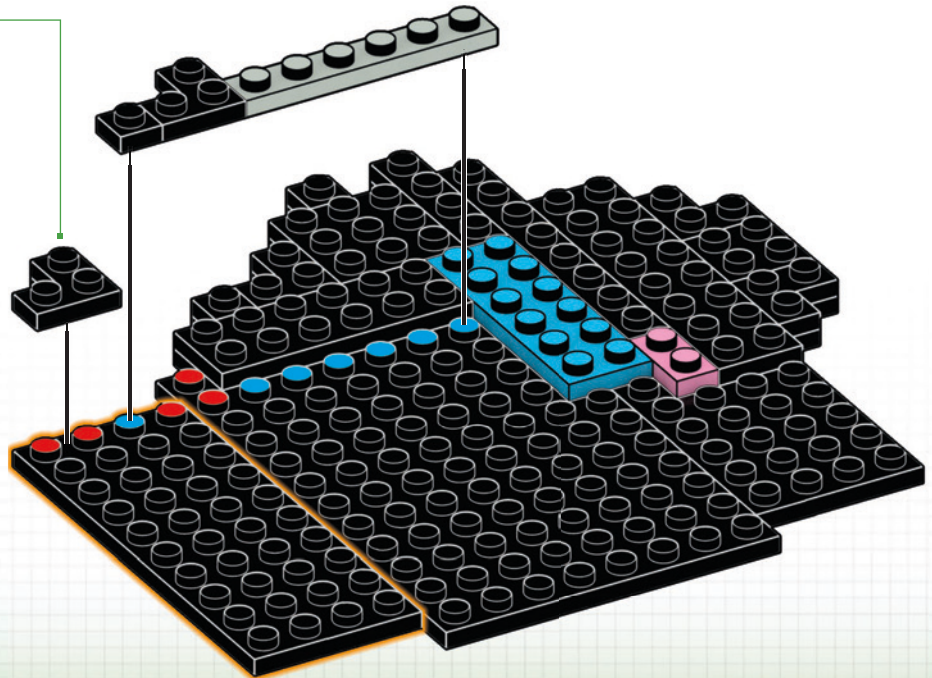

8



1x



1x



1x



1x

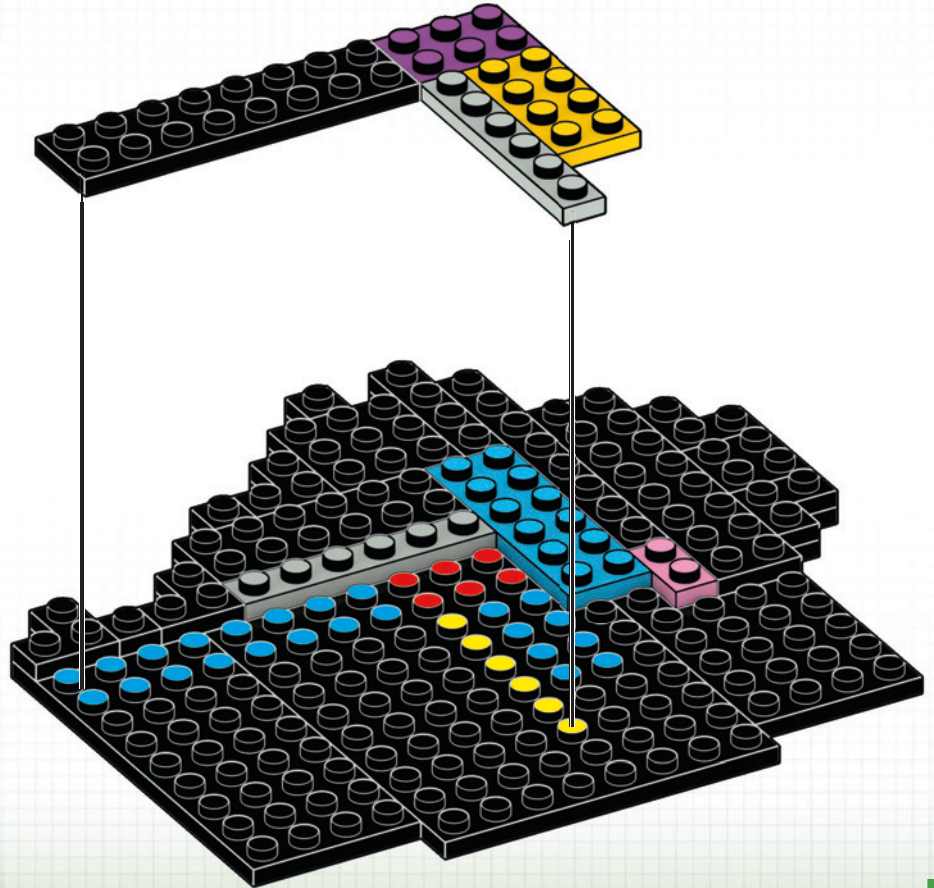

9

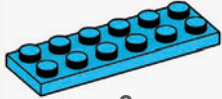

3x

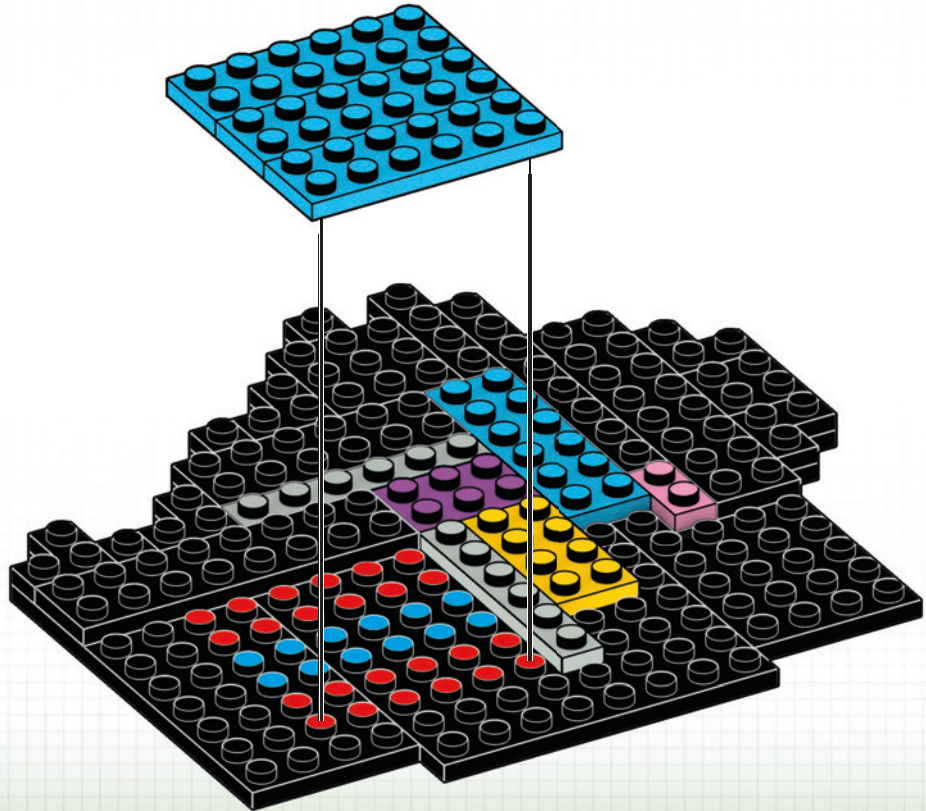

10



1x



2x



1x



1x

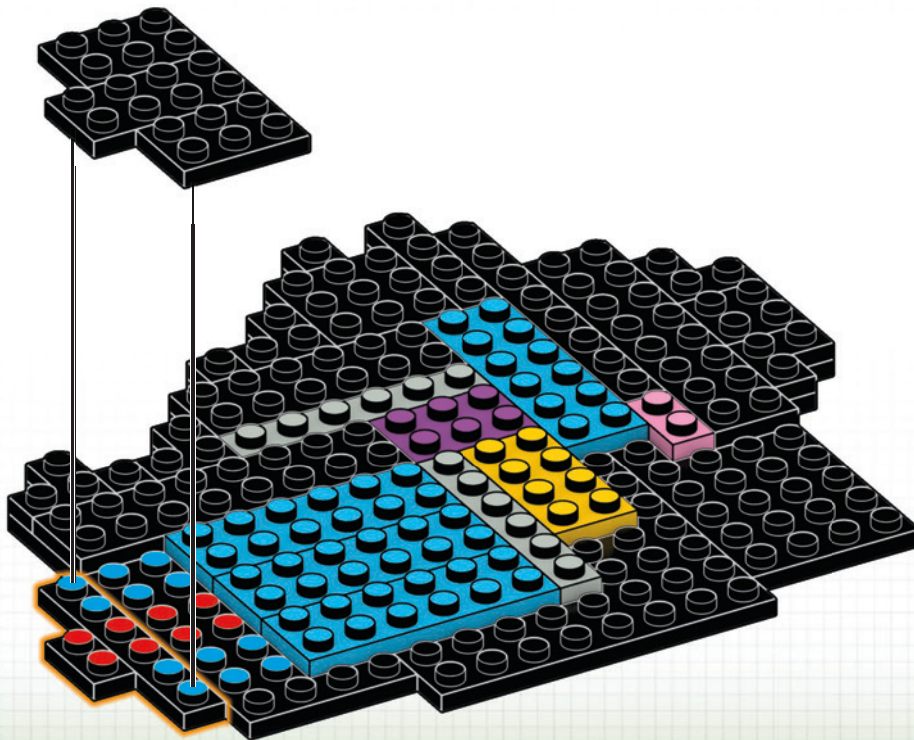

11



1x



2x



2x



1x

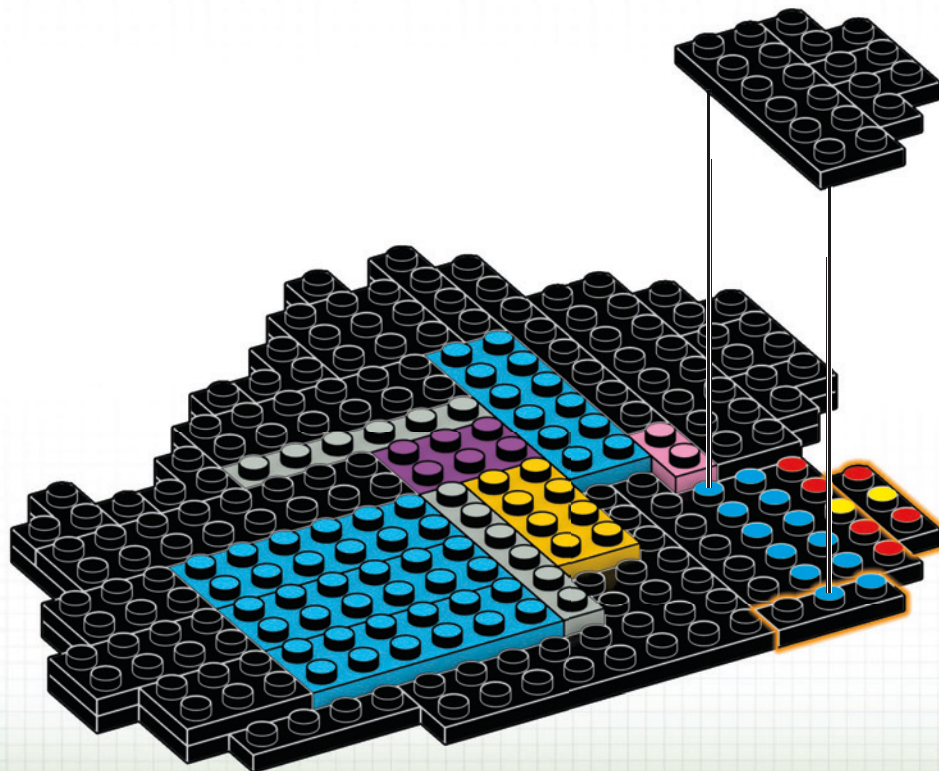

12



1x



1x



1x



1x

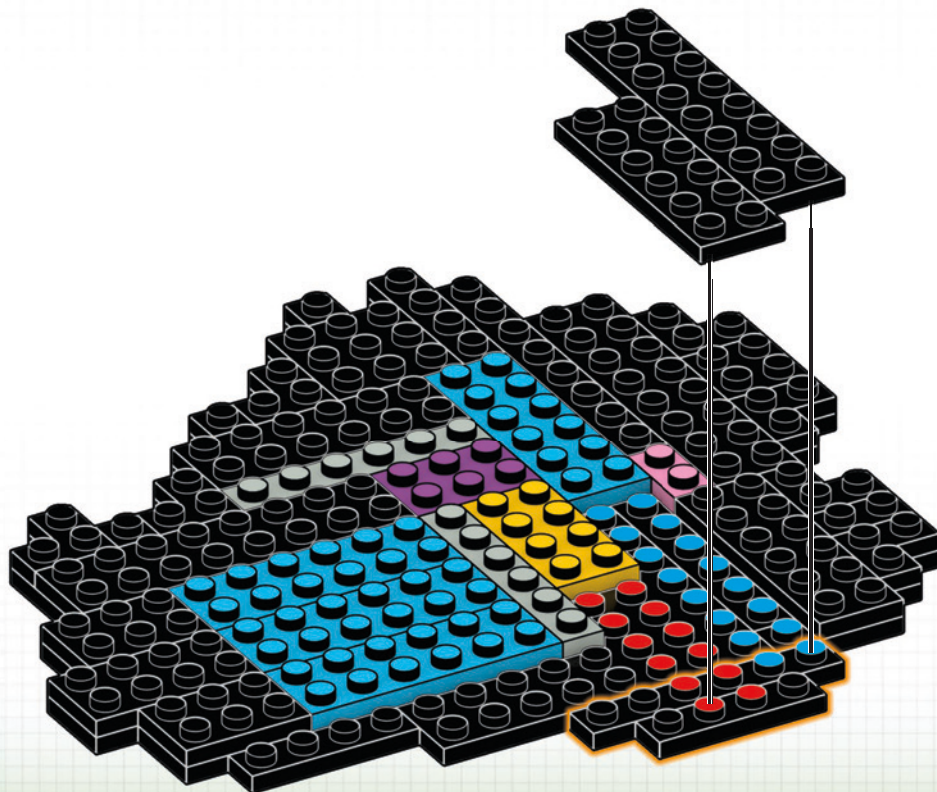

13



1x



3x



1x



1x



1x

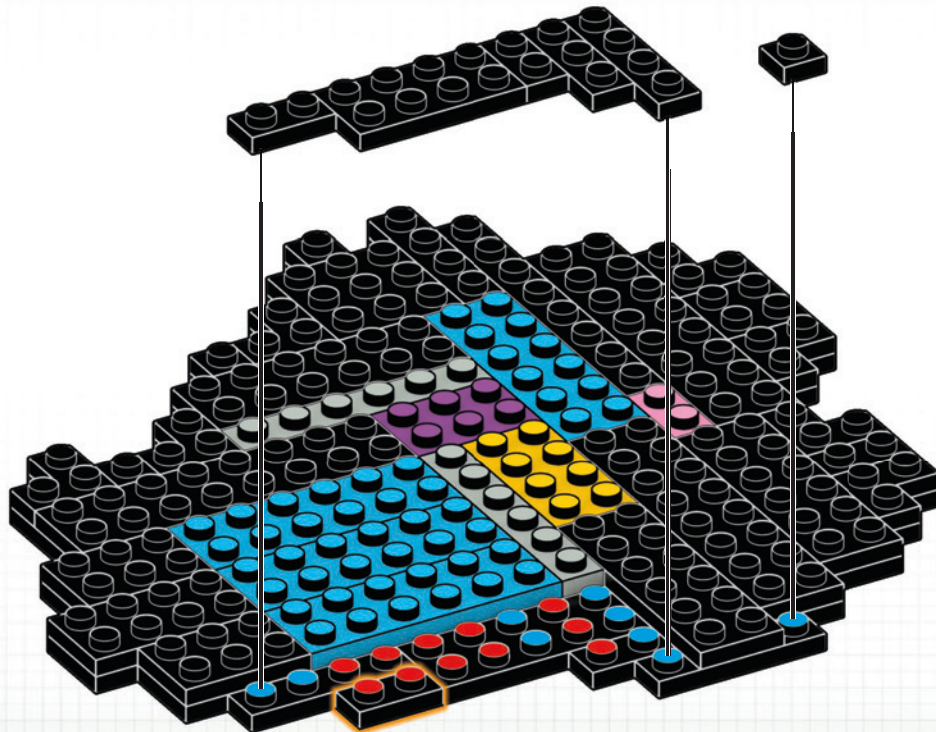

1

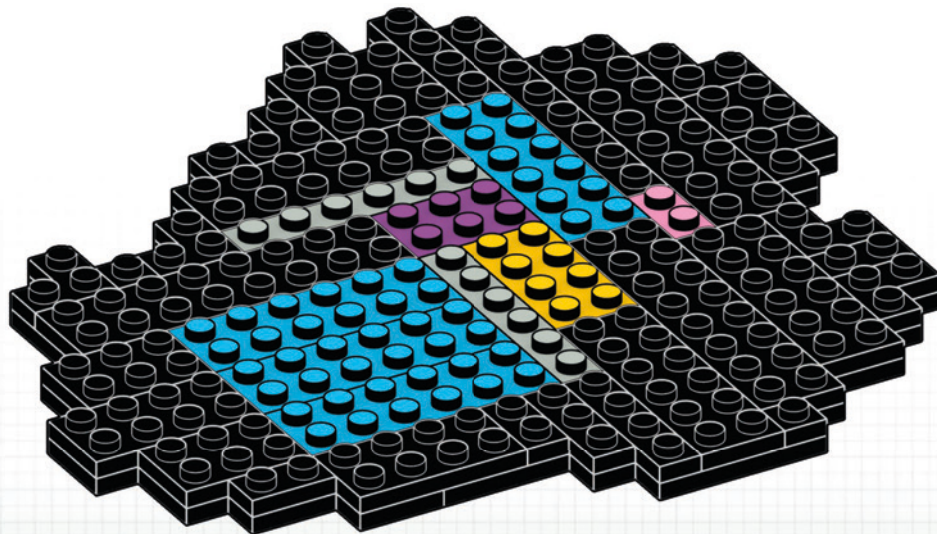

2

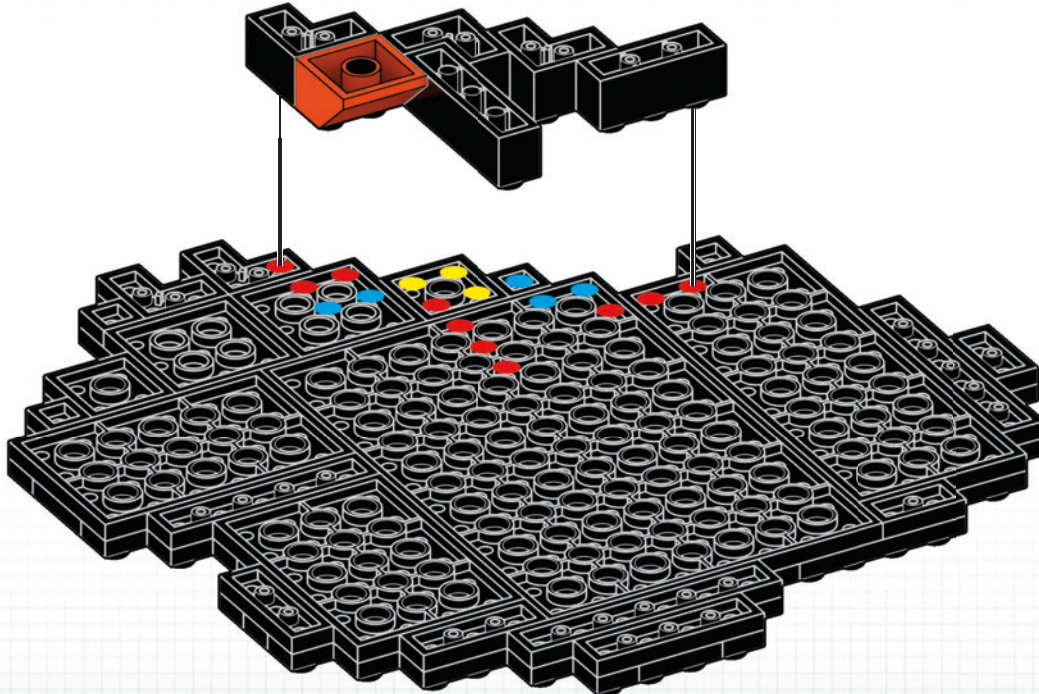
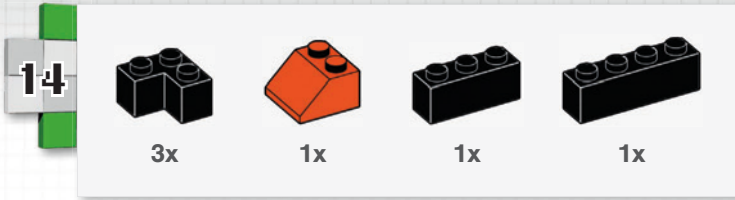

15



1x



5x

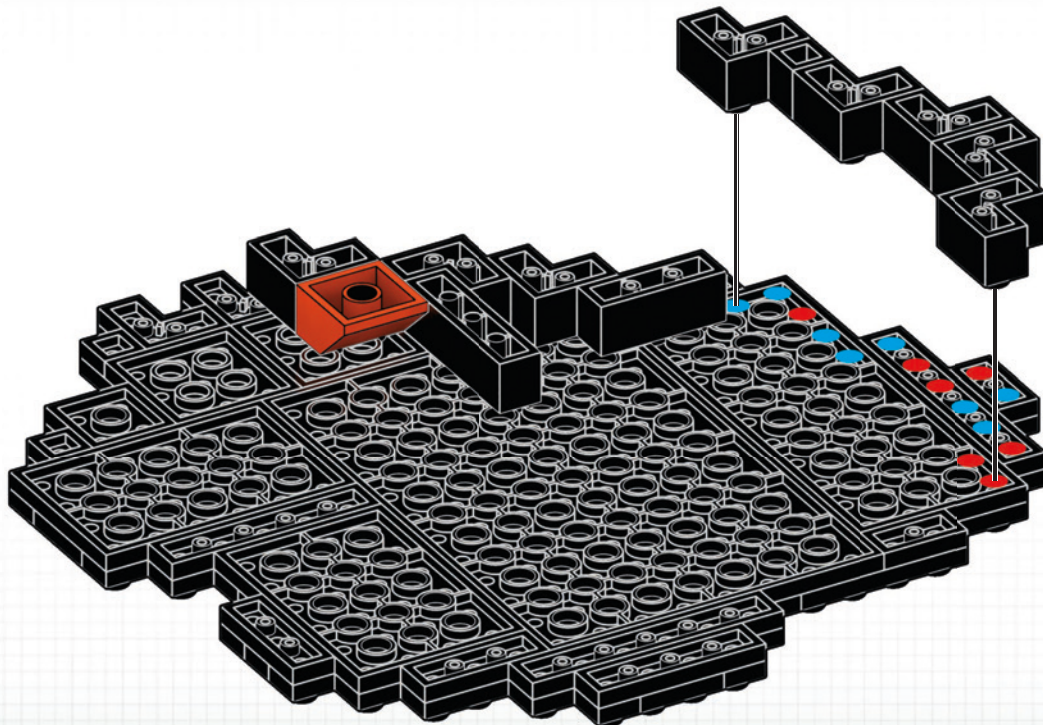

16



2x



1x



1x



1x



1x



1x

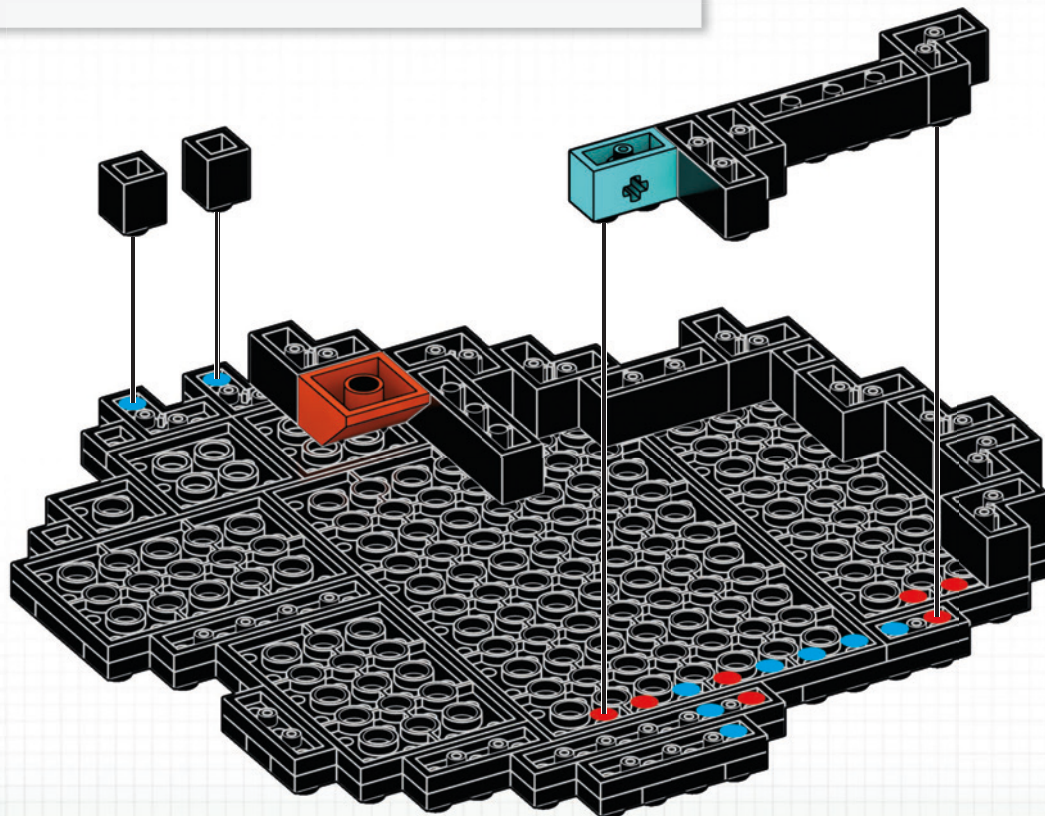

17



1x



1x



1x

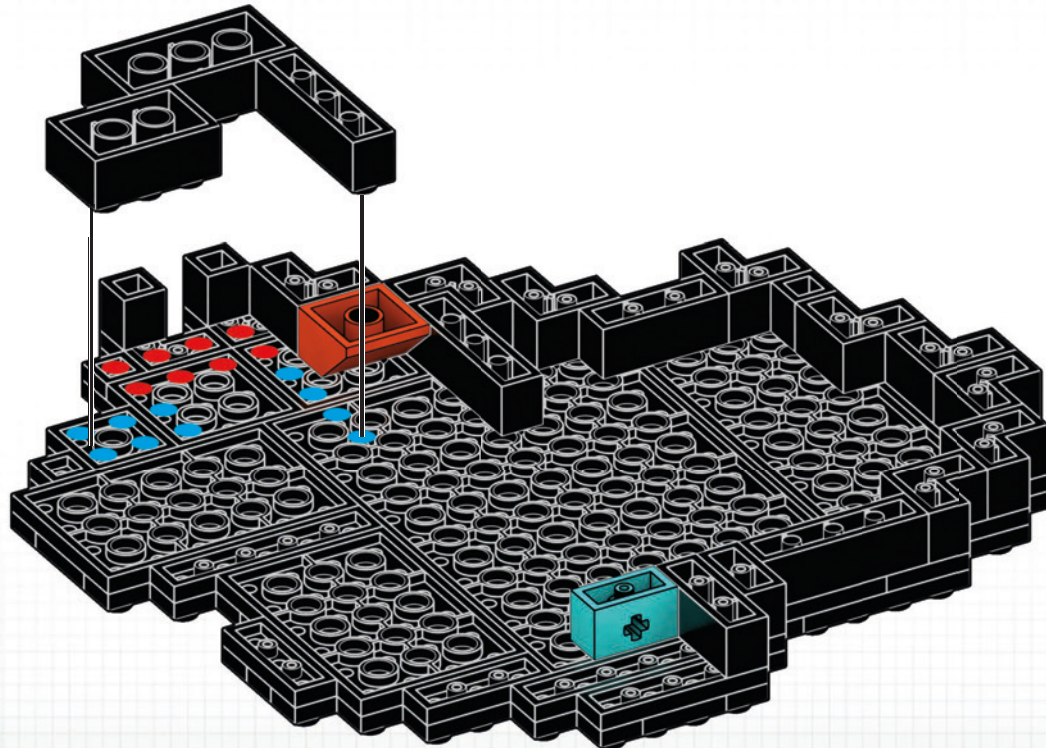

18



1x



3x



1x



1x

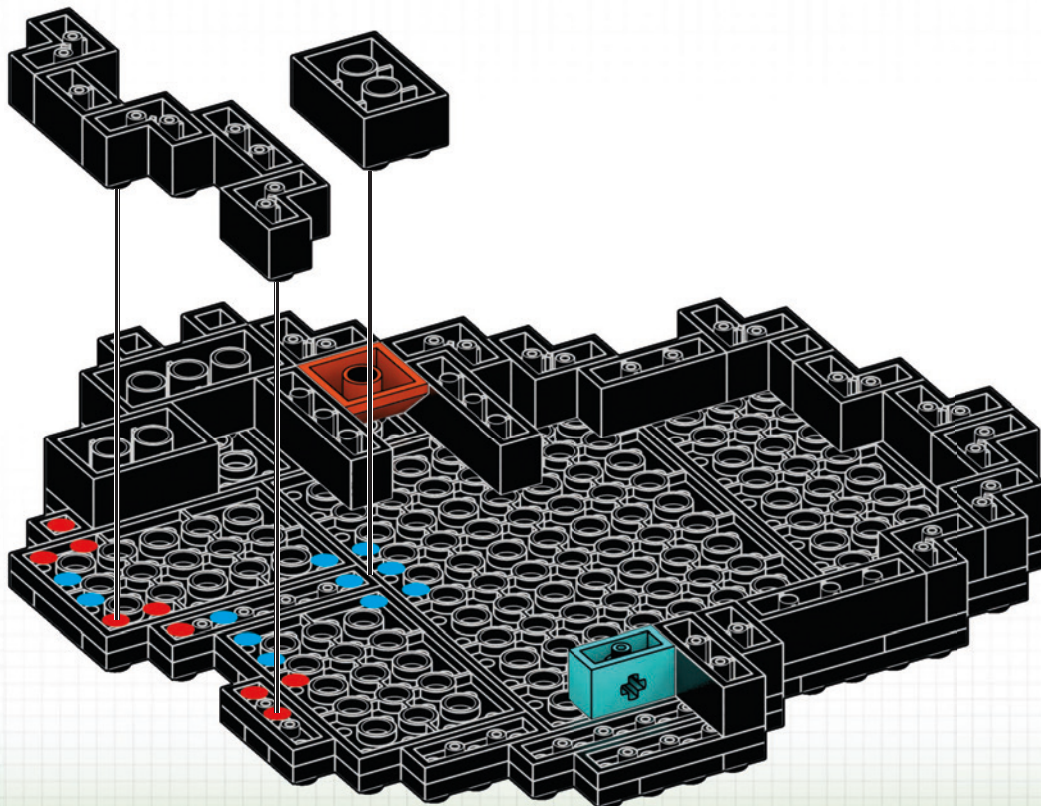

19



2x



1x



1x



2x

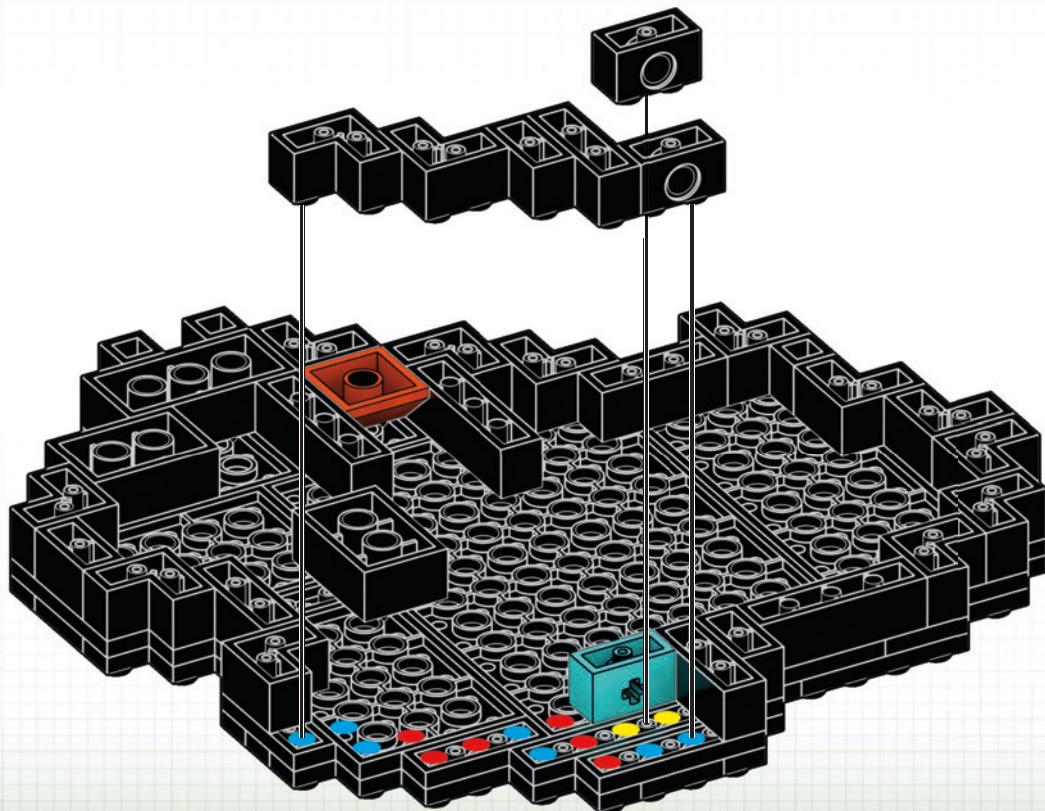

20



1x



3x

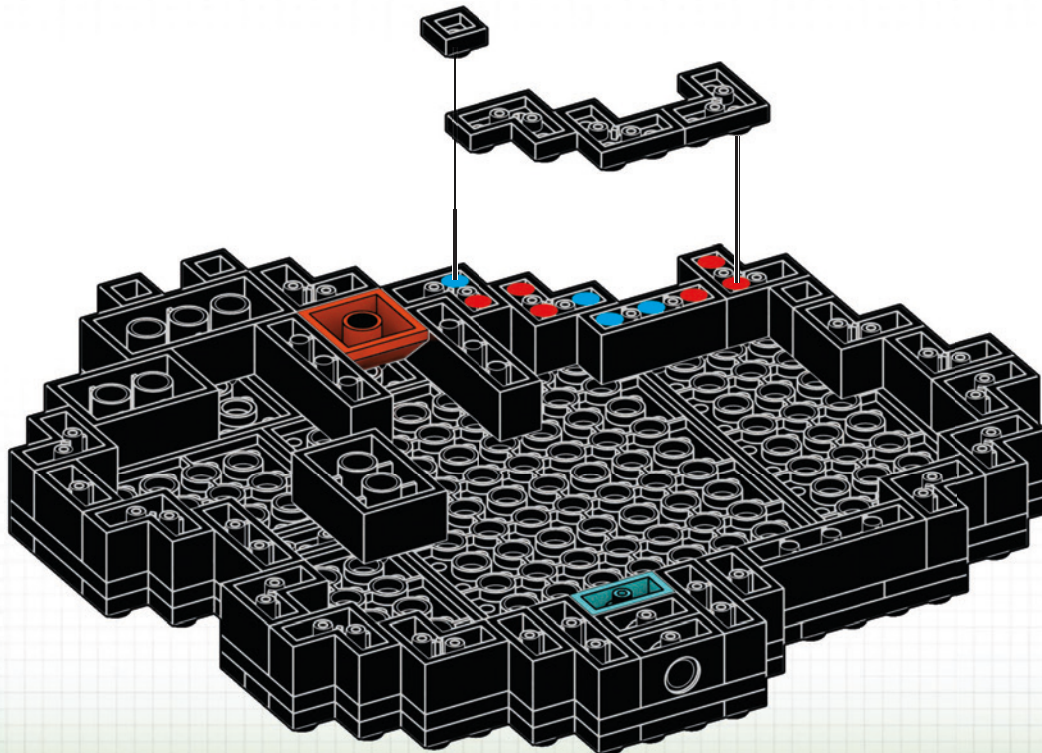

21



2x



1x

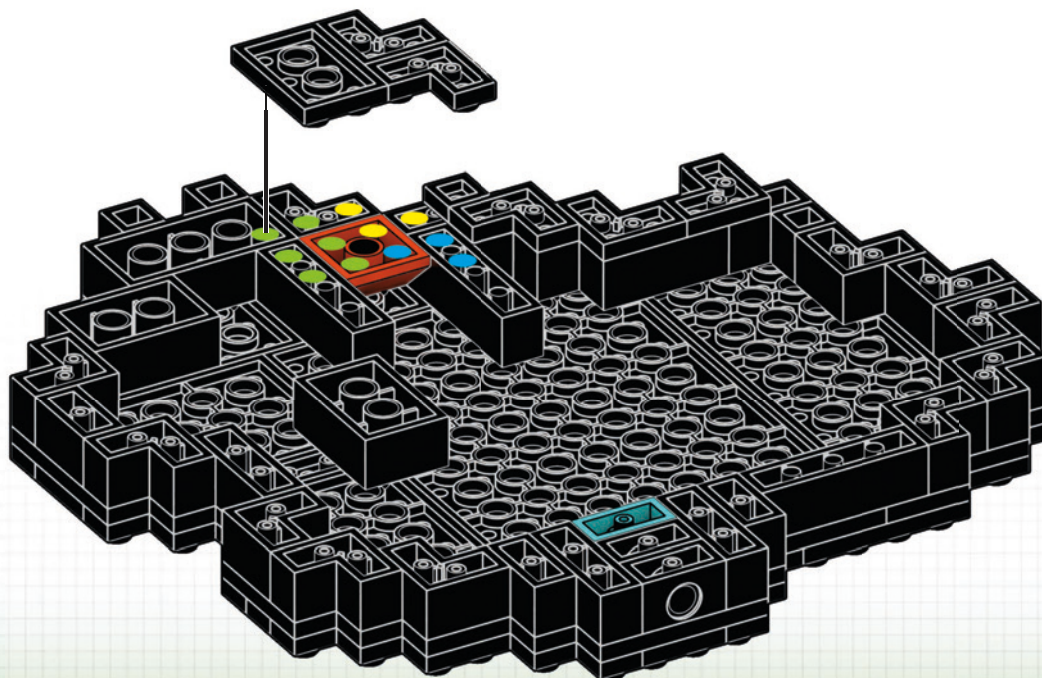

22



1x



1x



2x



1x

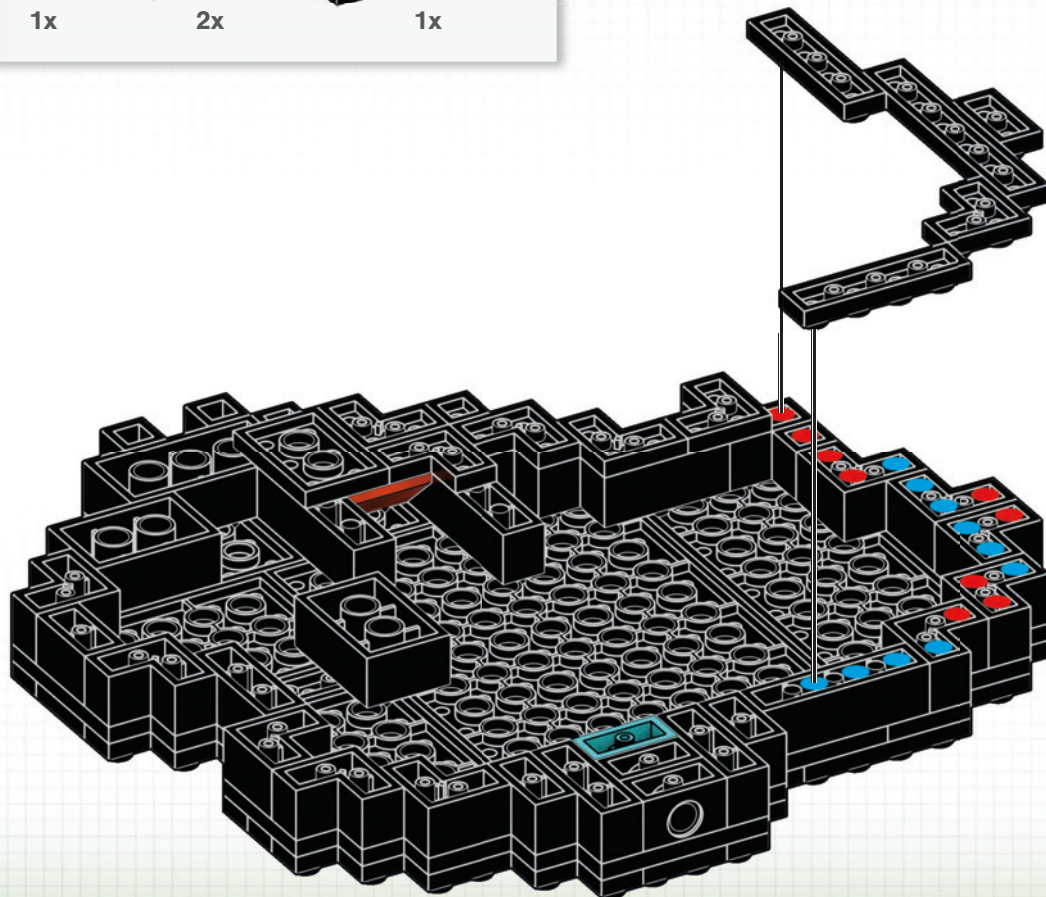

23



1x



2x



1x



1x



1x

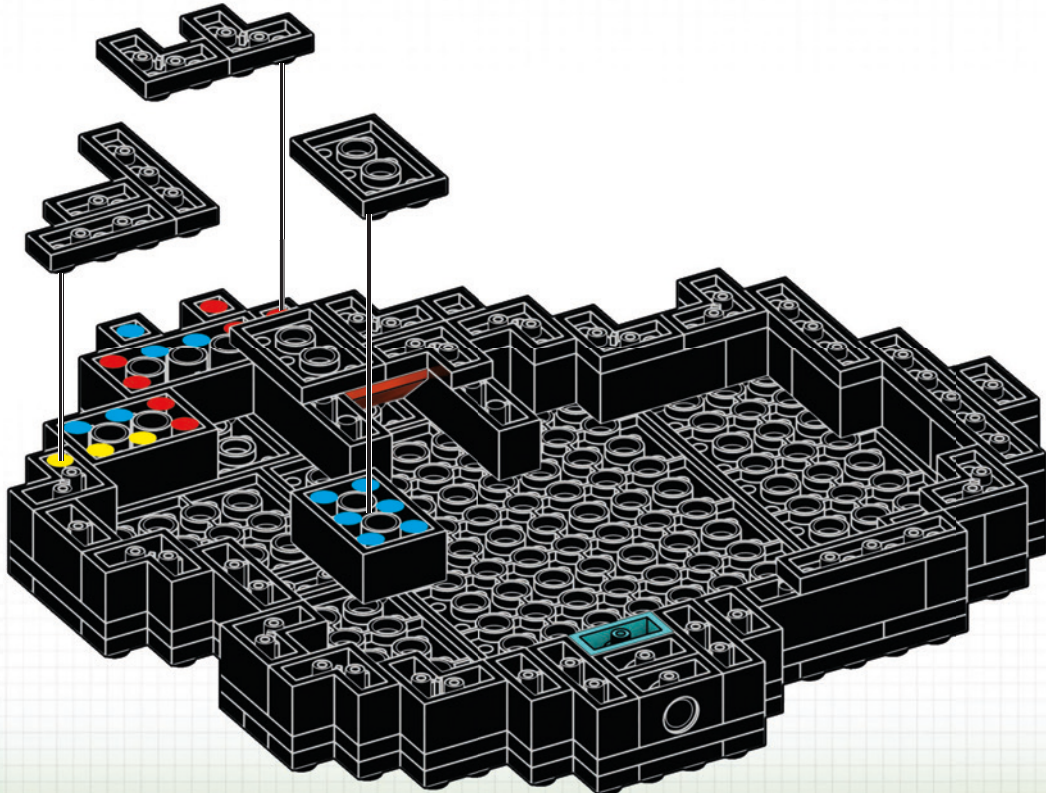

24



2x

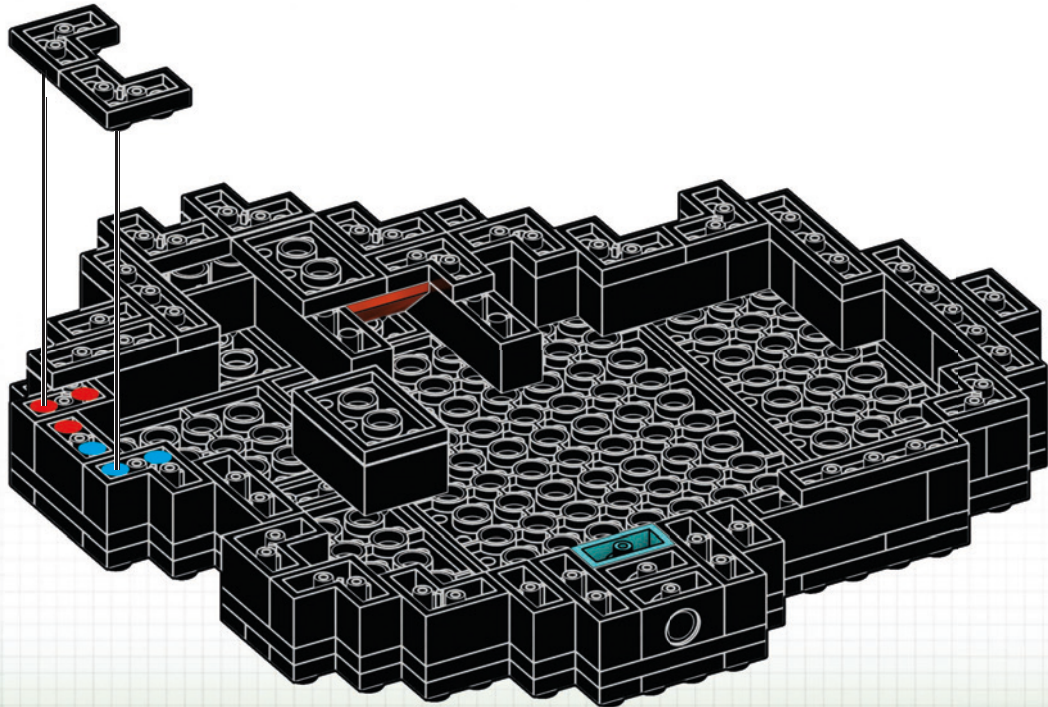

25



4x

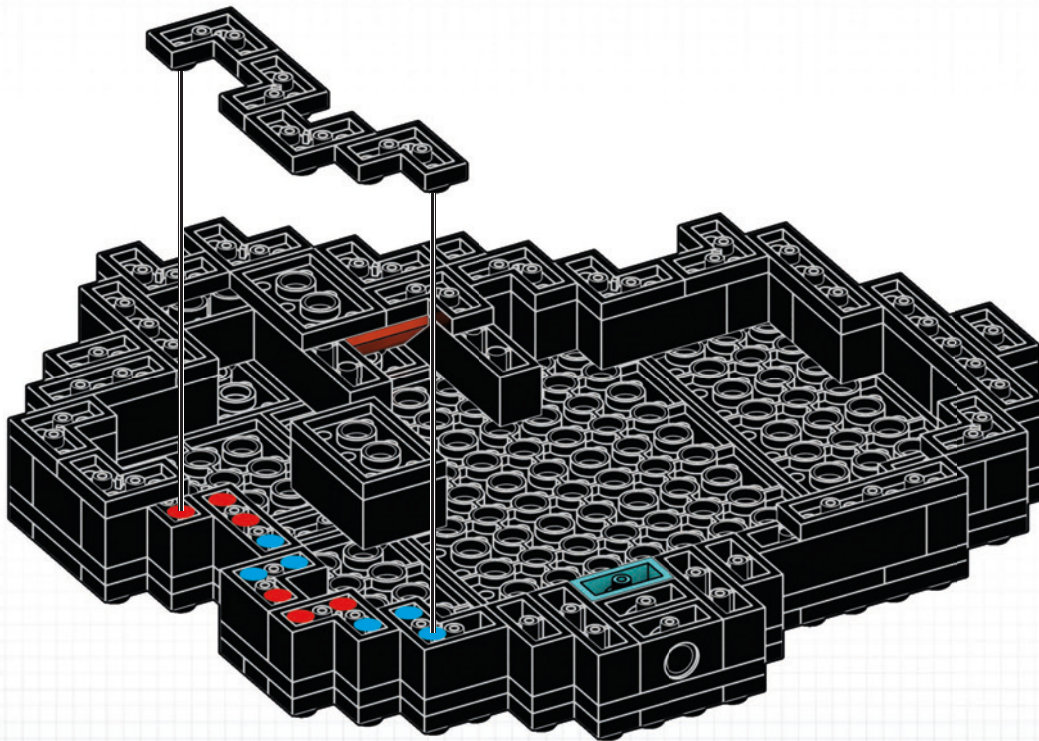

26



1x



1x



1x

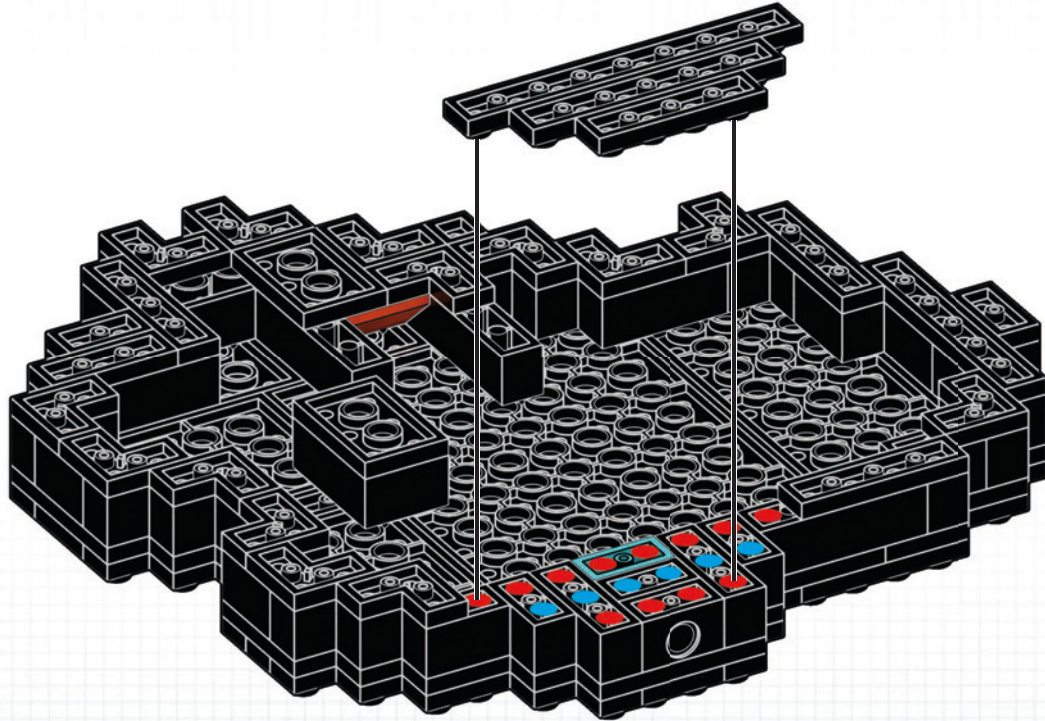

1

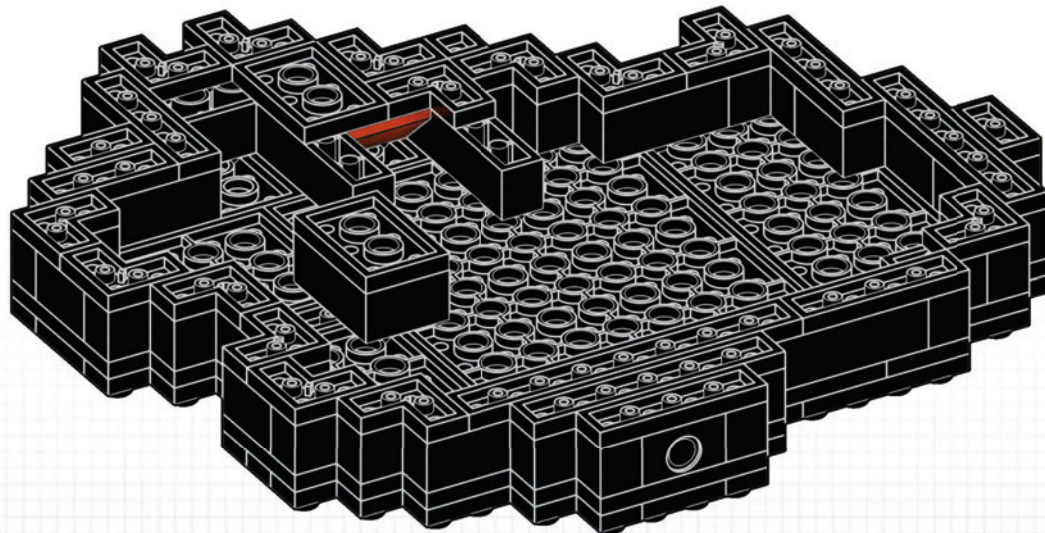

2



Building Tool Outil de construction

Herramienta de construcción
Bauwerkzeug
Ferramenta de montagem
Инструмент для конструирования

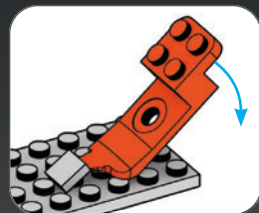

BUILD THE SWATCH TOOL. CONSTRUISEZ L'OUTIL ÉCHANTILLON.

CREA LA HERRAMIENTA DE MUESTRA.
CONSTRÓI A FERRAMENTA DE AMOSTRAS.
DAS MUSTERWERKZEUG ZUSAMMENBAUEN.
СОБЕРИТЕ ИНСТРУМЕНТ С ОБРАЗЦАМИ.

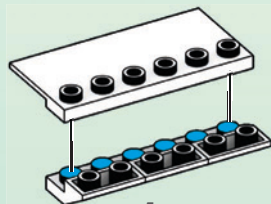

1

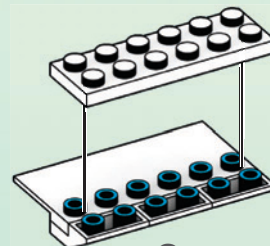

2

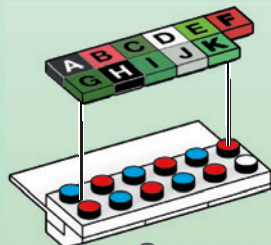

3



4



**USE THE SWATCH AS REFERENCE TO PLACE THE PIECES.
UTILISEZ L'ÉCHANTILLON COMME RÉFÉRENCE POUR PLACER LES PIÈCES.**

UTILIZA LA HERRAMIENTA DE MUESTRA COMOREFERENCIA PARA COLOCAR LAS PIEZAS.

COLOCA AS PEÇAS UTILIZANDO AS AMOSTRAS COMO REFERÊNCIA.

DAS MUSTER ALS REFERENZ ZUR ANORDNUNG DER TEILE VERWENDEN.

ИСПОЛЬЗУЙТЕ ИНСТРУМЕНТ С ОБРАЗЦАМИ, ЧТОБЫ ПОНИМАТЬ, КАК РАЗМЕЩАТЬ ДЕТАЛИ.



AFTER COMPLETING A LINE, USE THE TOOL TO STRAIGHTEN THE PIECES.
APRÈS AVOIR COMPLÉTÉ UNE LIGNE, UTILISEZ L'OUTIL POUR REDRESSER LES PIÈCES.
TRAS COMPLETAR UNA LÍNEA, UTILIZA LA HERRAMIENTA PARA ENDEREZAR LAS PIEZAS.
DEPOIS DE CONCLUÍRES UMA LINHA, UTILIZA A FERRAMENTA PARA ENDEREITAR AS PEÇAS.
NACH VOLLENDUNG EINER ZEILE DAS WERKZEUG ZUM GERADERICHTEN DER TEILE VERWENDEN.
КОГДА СОБЕРЕТЕ ЛИНИЮ, ИСПОЛЬЗУЙТЕ ИНСТРУМЕНТ ДЛЯ ВЫРАВНИВАНИЯ ДЕТАЛЕЙ.

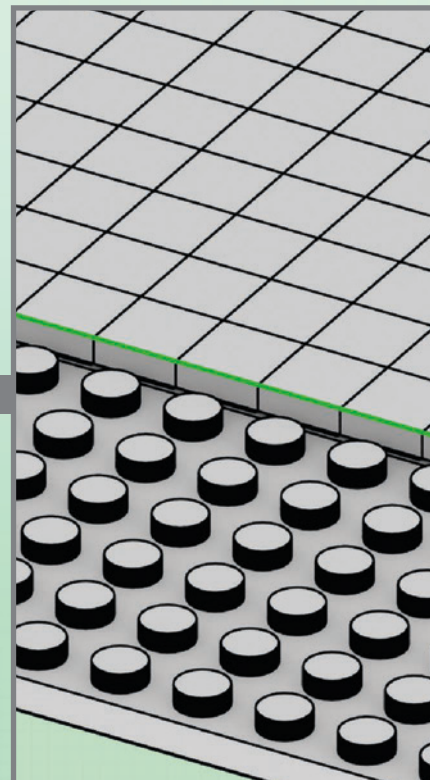
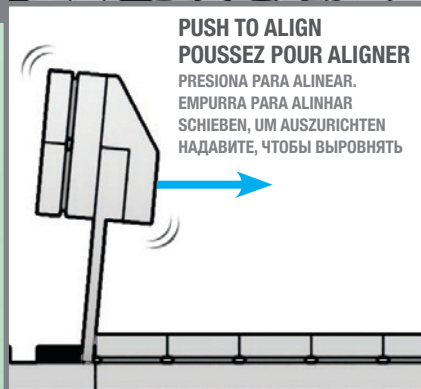
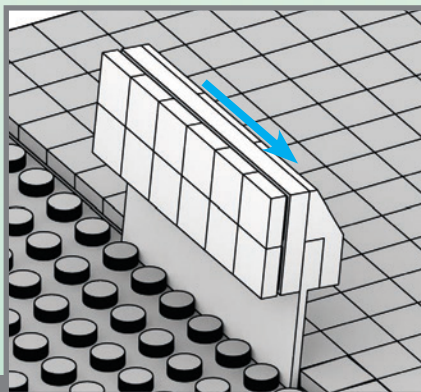
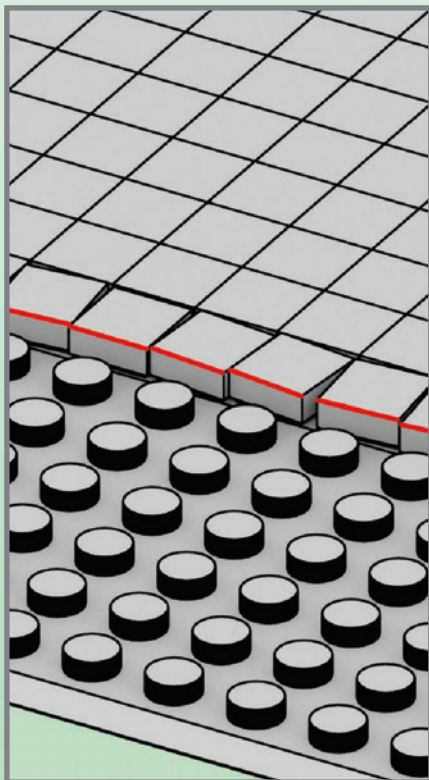

USING THE LETTERS AS YOUR GUIDE, EMPTY THE BAGS INTO THE CORRESPONDING SECTIONS OF THE TRAY.
EN UTILISANT LES LETTRES COMME GUIDE, VIDEZ LES SACS DANS LES SECTIONS CORRESPONDANTES DU PLATEAU.

UTILIZA LAS LETRAS COMO GUÍA Y VACÍA LAS BOLSAS EN LAS SECCIONES CORRESPONDIENTES DE LA BANDEJA.

UTILIZANDO AS LETRAS COMO ORIENTAÇÃO, ESVAZIA OS SACOS NAS SEÇÕES CORRESPONDENTES DO TABULEIRO.

DIE BEUTEL ANHAND DER BUCHSTABEN IN DIE ENTSPRECHENDEN ABSCHNITTE DES TABLETS ENTLEREEN.

ВЫСЫПЬТЕ СОДЕРЖИМОЕ ПАКЕТИКОВ В СООТВЕТСТВУЮЩИЕ ОТДЕЛЕНИЯ ПОДСТАВКИ ПО БУКВАМ.

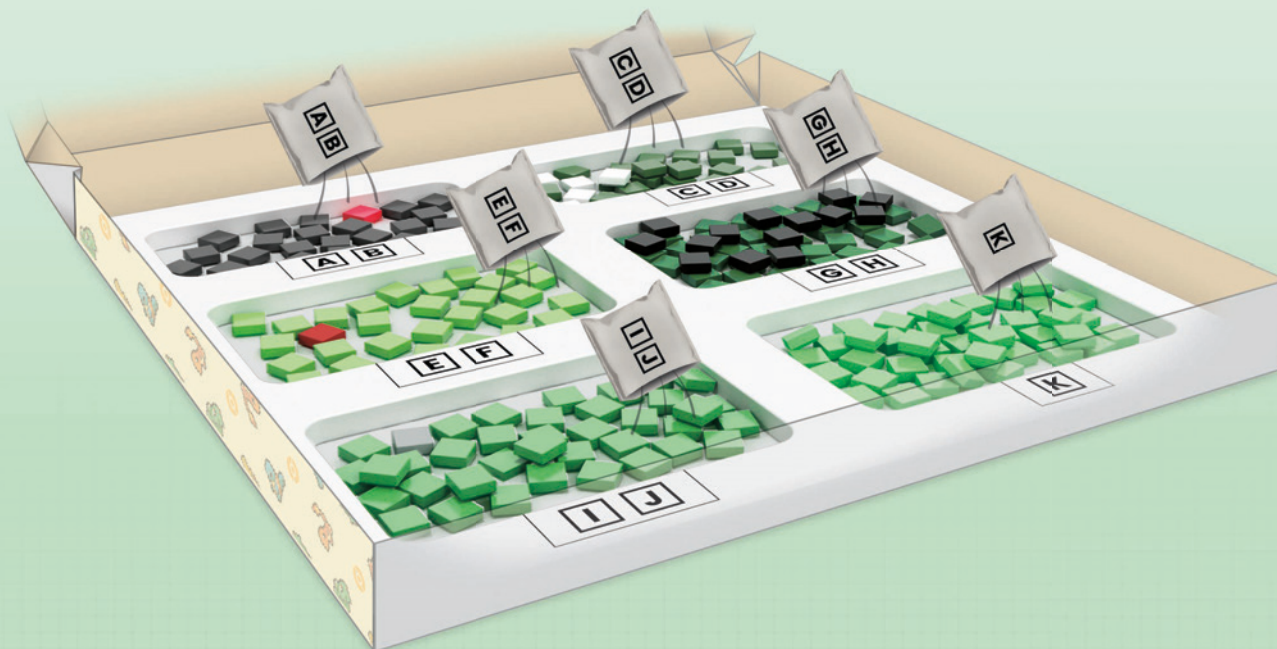



**FOLLOW THE GRID TO
PLACE THE PIECES.
SUIVEZ LA GRILLE POUR
PLACER LES PIÈCES.**

SIGUE LA CUADRÍCULA PARA
COLOCAR LAS PIEZAS.

COLOCA AS PEÇAS DE ACORDO
COM A GRELHA.

DIE TABELLE ZUR ANORDNUNG
DER TEILE BEFOLGEN.

ОРИЕНТИРУЙТЕСЬ НА СЕТКУ,
РАЗМЕЩАЯ ДЕТАЛИ.

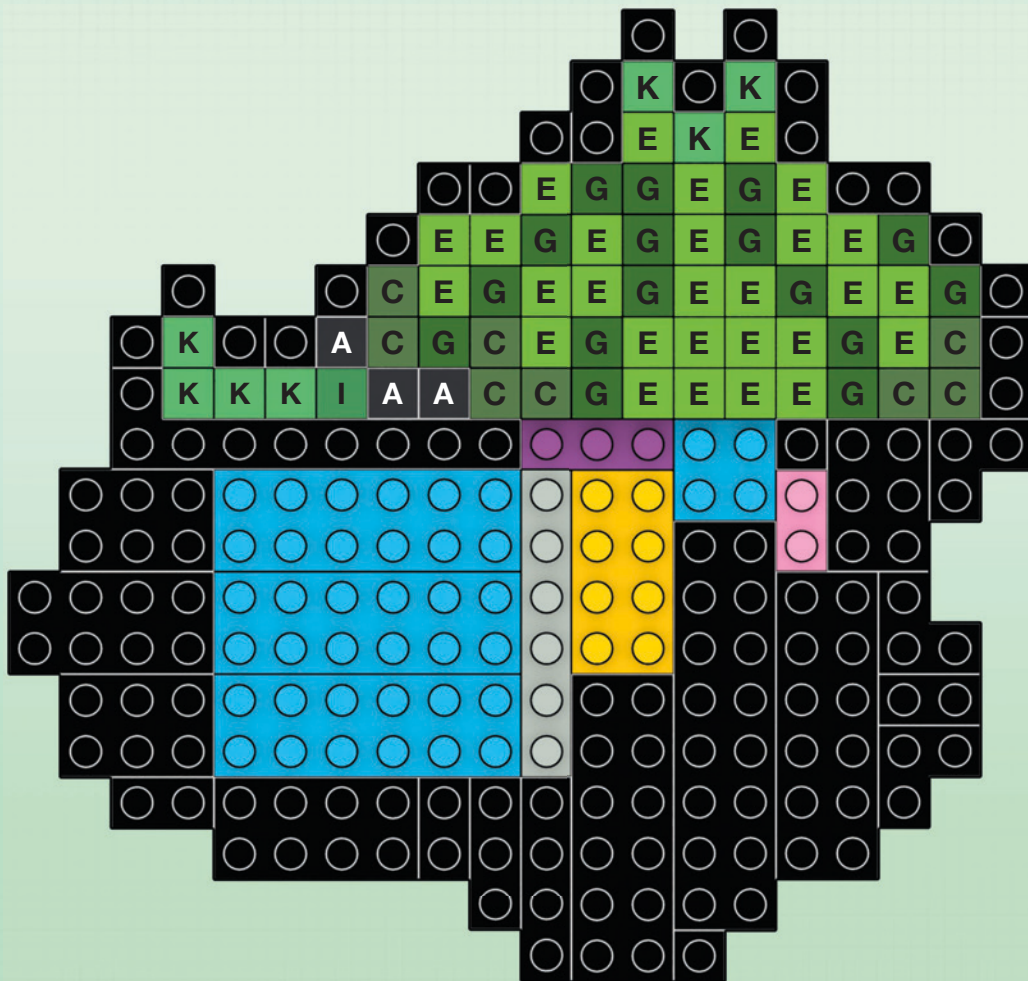

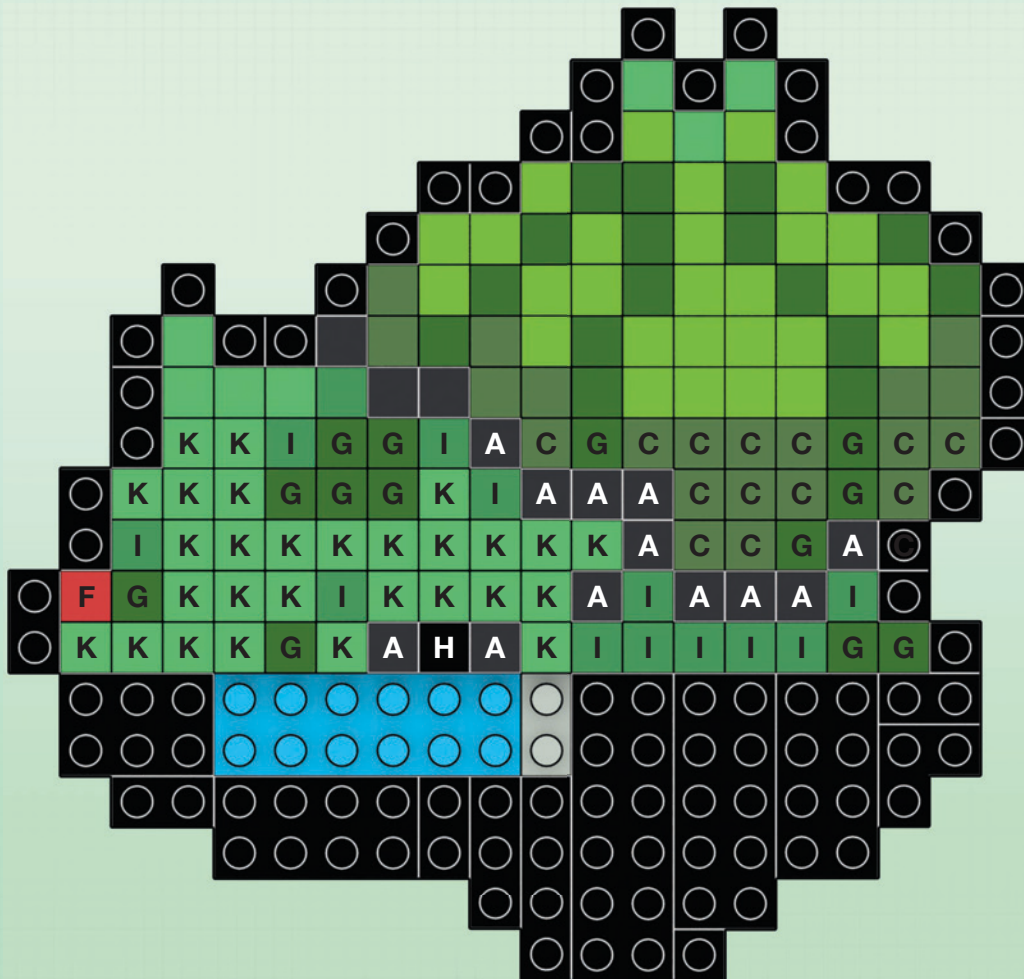

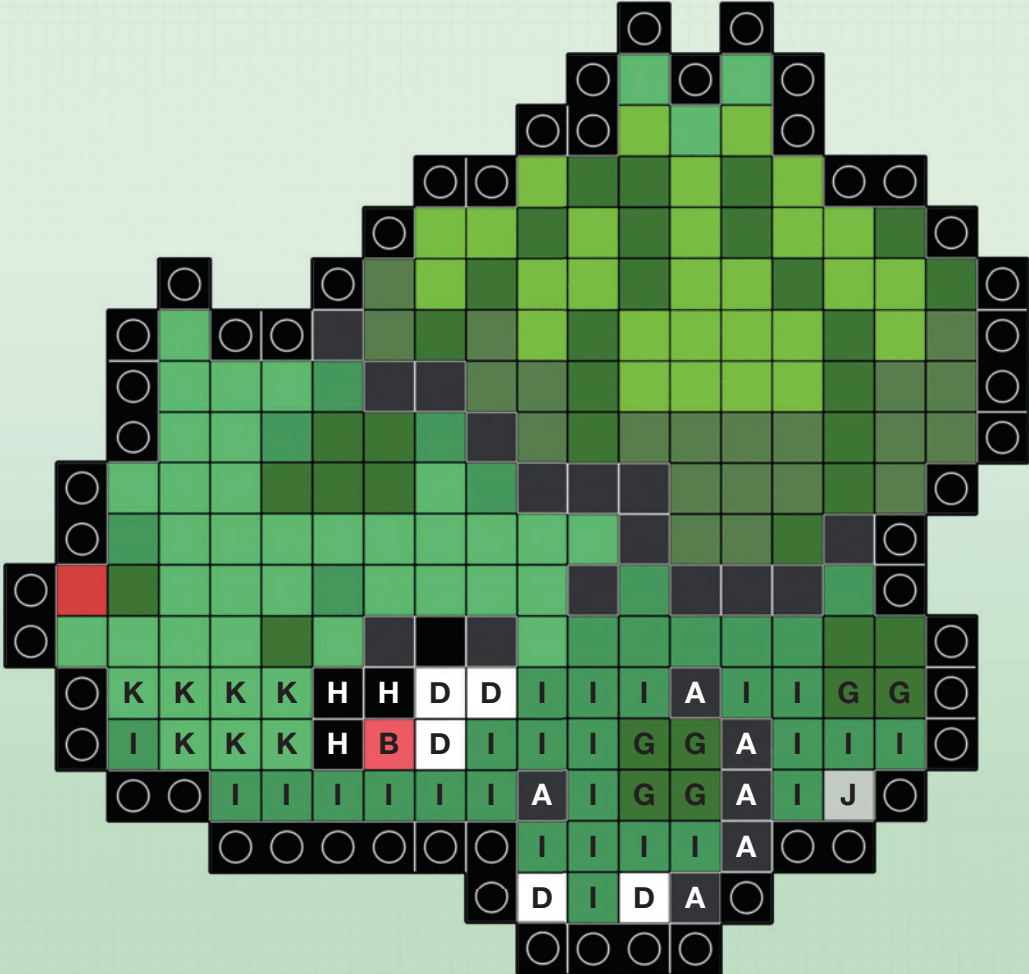



27



4x



2x



1x

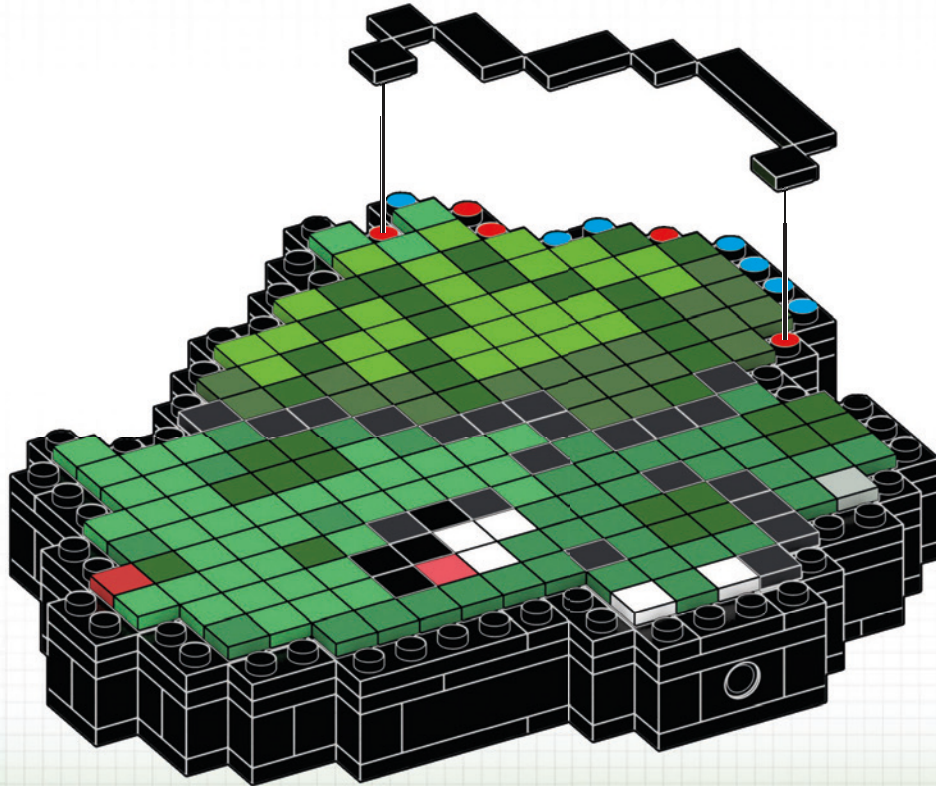

28



5x



3x

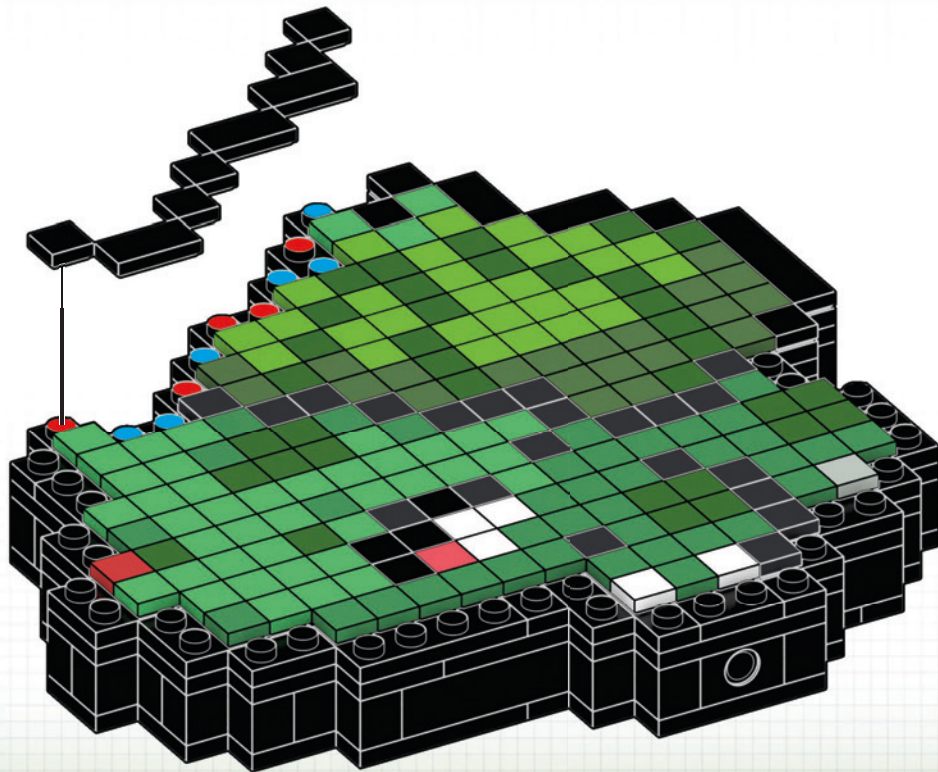

29



3x



1x

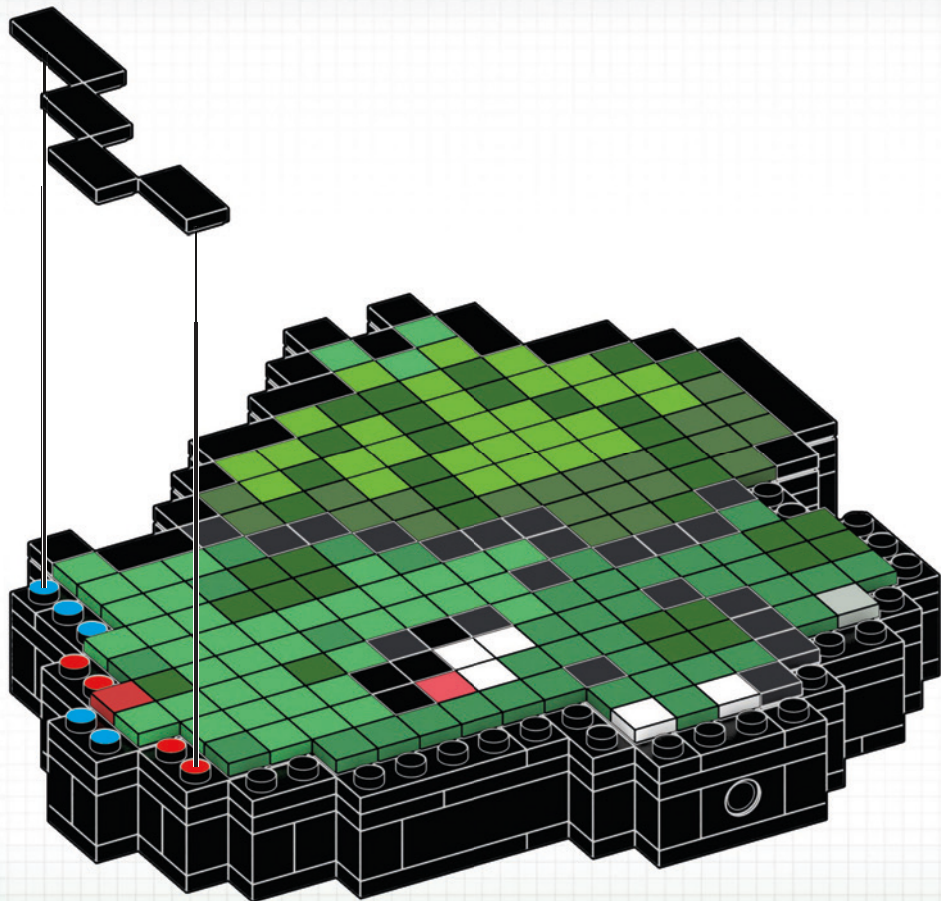

30



2x



2x



2x

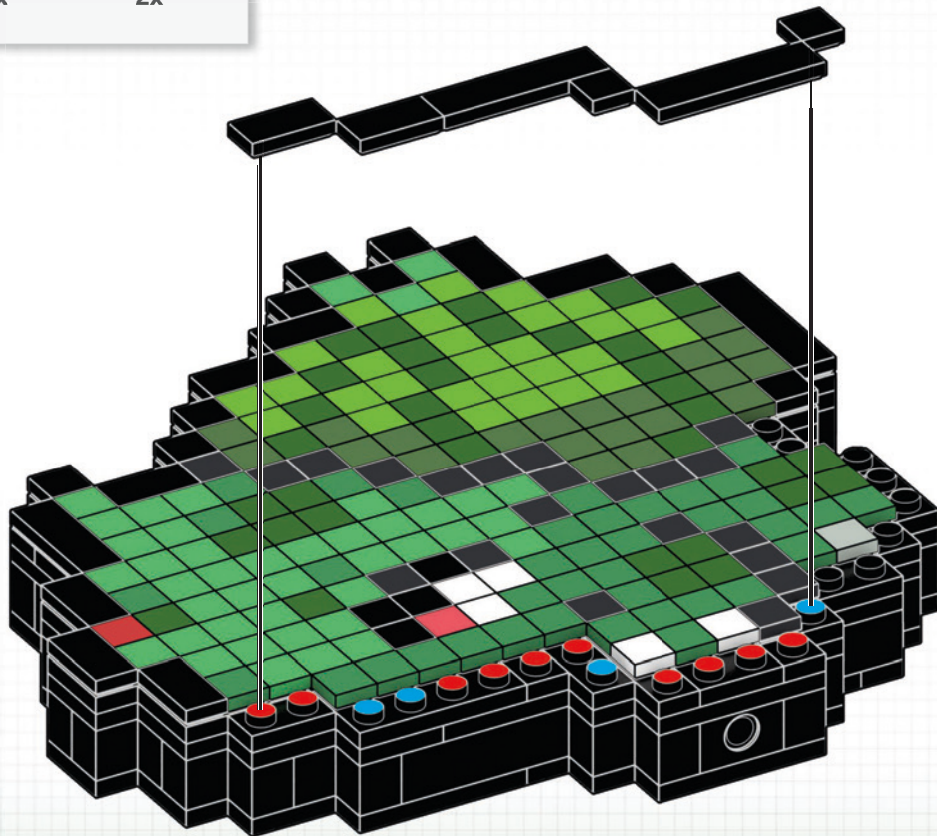

31



1x



2x



1x

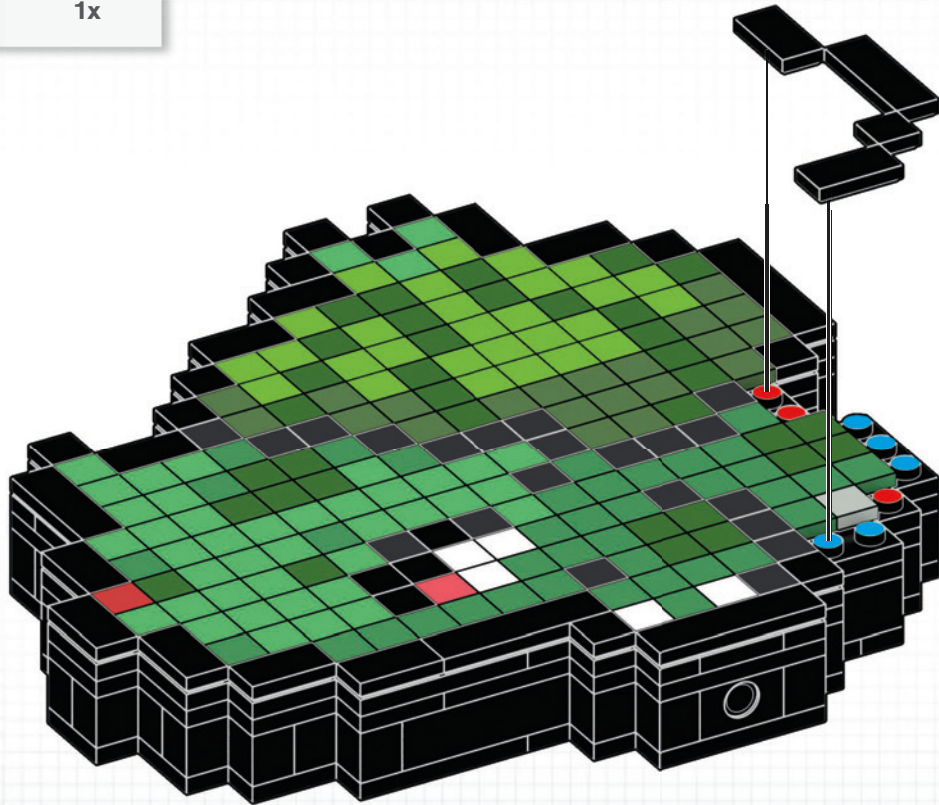

1

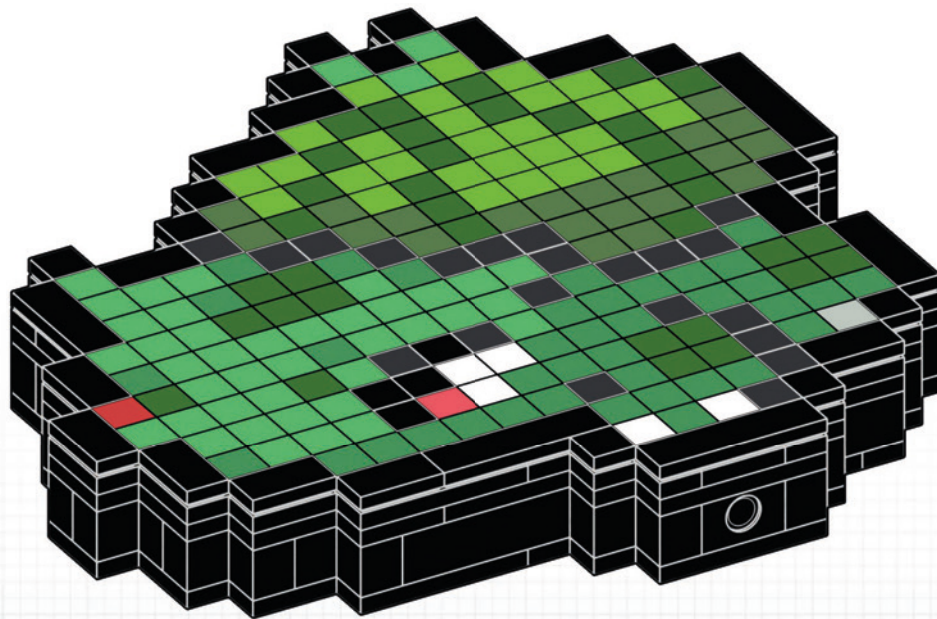

32

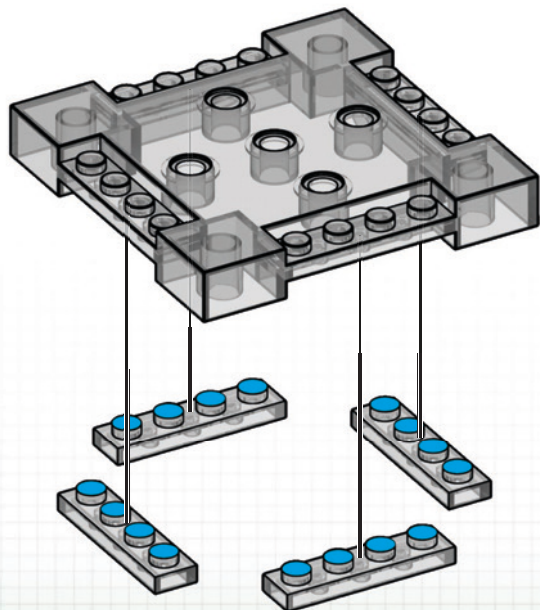
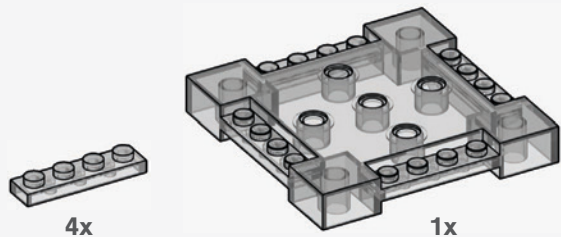

33



1x



4x

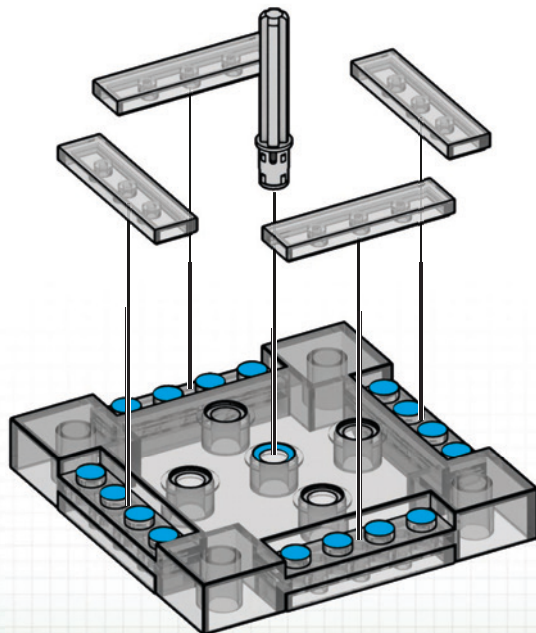

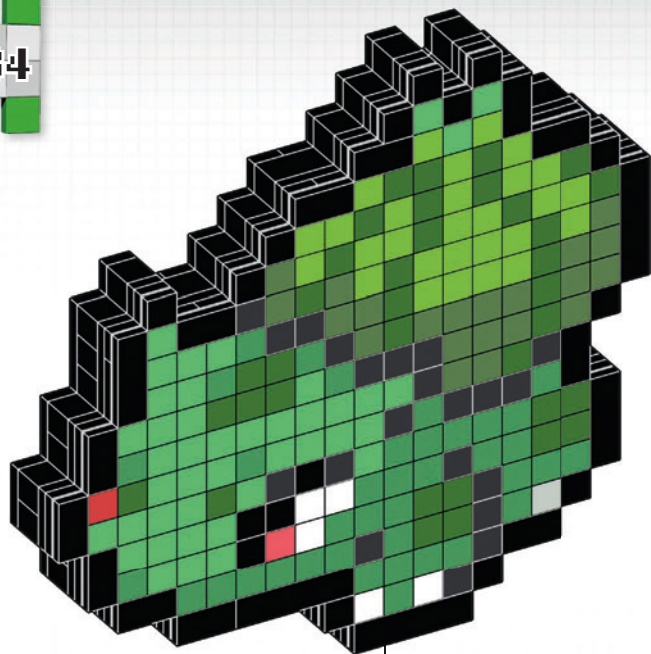

1

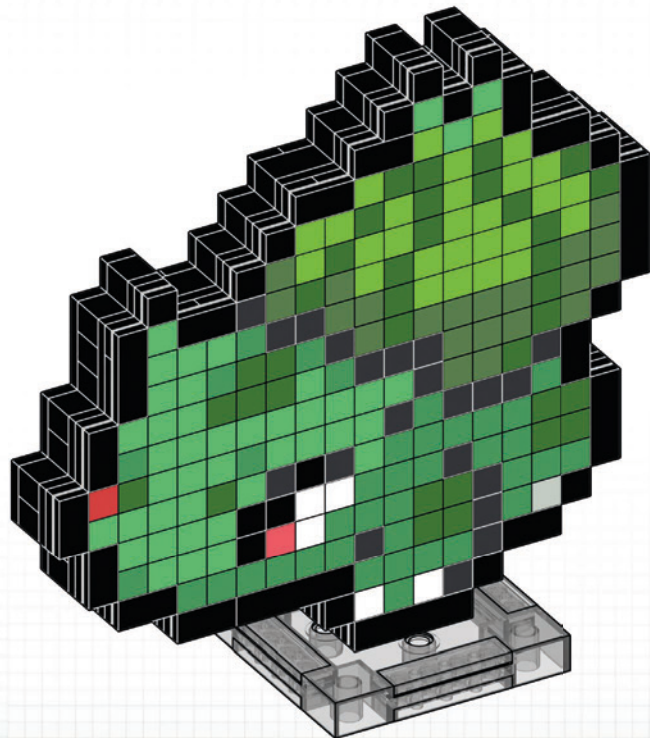

2

ATTACH IT TO THE BASE FOR DISPLAY
FIXEZ-LE À LA BASE POUR L'EXPOSER

COLOCA LA FIGURA EN LA BASE PARA EXPONERLA.
ENCAIXA A FIGURA NA BASE PARA EXPÔ-LA
ZUM AUSSTELLEN AM SOCKEL BEFESTIGEN
УСТАНОВИТЕ ФИГУРКУ НА ОСНОВАНИЕ, ЧТОБЫ ПОСТАВИТЬ ЕЕ



USE THE HOOK TO MOUNT IT ON THE WALL
UTILISEZ LE CROCHET POUR LE FIXER AU MUR

UTILIZA EL GANCHO PARA COLGARLO EN LA PARED
UTILIZA O GANCHO PARA PRENDÊ-LA NA PAREDE
MITHILFE DES HAKENS AN DER WAND BEFESTIGEN
ИСПОЛЬЗУЙТЕ КРЮЧОК ДЛЯ КРЕПЛЕНИЯ НА СТЕНУ



1

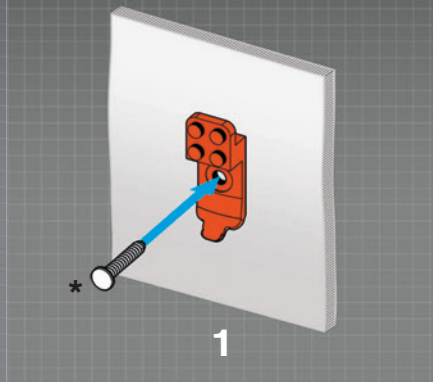

2

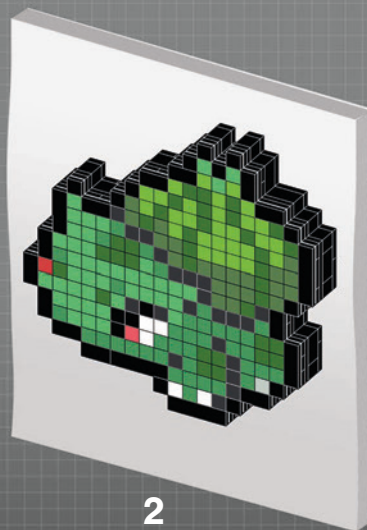
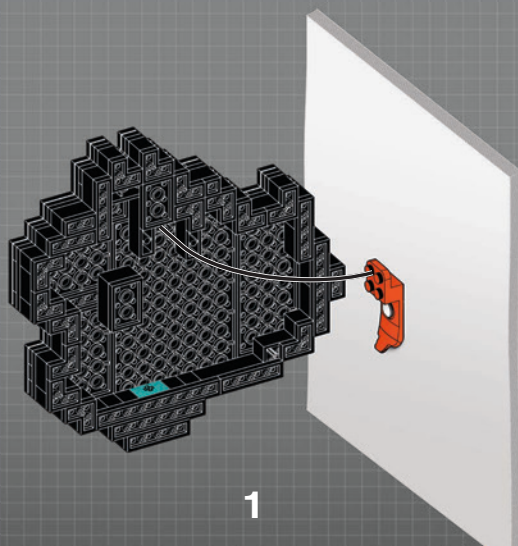

*Hardware not included / Matériel d'installation non inclus. / Equipo no incluido. / Hardware não incluído. / Componenti hardware non inclusi. / Hardware nicht enthalten. / Elementy montażowe nie znajdują się w zestawie. / Hardware niet inbegrepen. / Оборудование не входит в комплект. / Hardware medfølger ikke. / Skruvar och verktyg ingår inte. / Fastvare følger ikke med. / Tarvikkeet eivät sisälly pakkaukseen. / Δεν περιλαμβάνονται εργαλεία. / Donanım ürünü dahil değildir. / Náradí není součástí balení. / Hardvér nie je súčasťou balenia. / A hardver nem tartozék. / ハードウェアは商品に含まれていません。 / . الأجهزة غير متضمنة / 不含硬件

CONTENTS / CONTIENT / INHALT / CONTENUTO / INHOUD / CONTENIDO / CONTEÚDO / INNEHÅLL / SISÄLTÖ / INDEHOLDER /
 INNHOLD / ZAWIERA / OBSAH / TARTALOM / СОДЕРЖИМОЕ / ΠΕΡΙΕΧΟΜΕΝΑ / İÇİNDEKİLER / المحتويات

1x
AS-HTH75-01



1x
AS-HTH75-02



1x
AS-HTH75-03



1x
AS-HTH75-04



1x
AS-HTH75-05



1x
AS-HTH75-06



1x
AS-HTH75-07



1x
AS-HTH75-08



1x
AS-HTH75-09



1x
AS-HTH75-10



1x
AS-HTH75-11



21x
AM07223AYB



1x
AM07223RQ



21x
AM07223AZT



5x
AM07223E



28x
AM07223HT



1x
AM07223AZE



35x
AM07223ARD



16x
AM07223F



38x
AM07223AZS



1x
AM07223AKH



42x
AM07223AZB



9x
AM03328F



3x
AM01086F



12x
AM22501F



7x
AM09393F



1x
AM09393ASX



1x
AM80259ASU



2x
AM79877F



3x
AM09013F



23x
AM15484F



3x
AM03773F



3x
AM18223E



14x
AM17153F



1x
AM10273MCX



2x
AM80966F



4x
AM01314F



4x
AM16384F



1x
AM03772AEN



4x
AM03772F



2x
AM03873F



1x
AM80876AKH



4x
AM09838W



3x
AM09838F



7x
AM09593F



4x
AM09593W



3x
AM01087F



3x
AM81163F



2x
AM09493F



1x
AM09493BYE

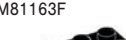

1x
AM09033F



1x
AM07475F



1x
AM81906MCX

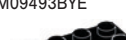

4x
AM09292F



2x
AM09292AKH



3x
AM01480F



4x
AM01480GD



1x
AM01480E



1x
AM01480E



1x
AM72333E



2x
AM17055F



2x
AM18298F



3x
AM08483F





1x
AM09924F

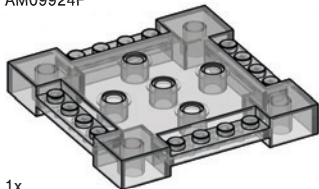

1x
AM81997W

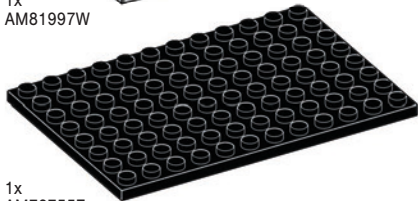

1x
AM73755F

Missing pieces? Pièces manquantes?

¿Partes faltantes? • Perdeu peças?
Fehlen Teile? • Не хватает деталей?



support.megabrand.com

WARNING:

**CHOKING HAZARD – Small parts.
Not for children under 3 years.**

ATTENTION :
DANGER D'ÉTOUFFEMENT –
PETITS ÉLÉMENTS. NE
CONVIENT PAS AUX ENFANTS
DE MOINS DE 36 MOIS.

ATENÇÃO: NÃO INDICADO / NÃO RECOMENDÁVEL PARA CRIANÇAS MENORES DE 3 (TRÊS) ANOS POR CONTER PARTE(S) PEQUENA(S) QUE PODE(M) SER ENGOLIDA(S) OU ASPIRADA(S) PODENDO PROVOCAR ASFIXIA.

WARNING: Small parts, ATTENTION : PETITS ÉLÉMENTS, ACHTUNG:
Kleine Teile, AVVERTENZA: Piccole parti, WAARSCHUWING: Kleine
onderdelen, ADVERTENCIA: PELIGRO DE ATRAGANTAMIENTO. Juguete
no recomendado para menores de 3 años, porque contiene piezas
pequeñas que podrían provocar asfixia en caso de ser ingeridas o inhaladas por
el/la niño/a, VARNING: Små delar, VAROITUS: Pieniä osia, ADVARSEL: Små dele,
ADVARSEL: Små deler, OSTRZEŻENIE: Małe części, UPOZORNĚNÍ: Malé části,
UPOZORNENIE: Malé časti, FIGYELMEZTETÉS: Kis alkatrészek, ПРЕДУПРЕЖДЕНИЕ:
Мелкие детали, ΠΡΟΕΙΔΟΠΟΙΗΣΗ: Μικρά κομμάτια, UYARI: Küçük parçalar.

警告:
のどにつまる危険小さな部品が含まれています 3歳以下の子供には与えないで下さい。

警告! 不适合3岁以下儿童使用。内含小零件。



0-3

Mattel Europa B.V., Gondel 1, 1186 MJ Amstelveen, Nederland. Mattel U.K. Limited, The Porter Building, 1Brunel Way, Slough SL1 1FQ, UK. Mattel France, Parc de la Cerisaie, 1/3/5 allée des Fleurs, 94260 Fresnes Cedex. N° Cristal 0969 36 99 99 (Numéro non surtaxé) ou www.lesjouetsmattel.fr Mattel Belgium N.V. De Kleeflaan 4, 1831 Machelen (Diegem) Belgium. Deutschland : Mattel GmbH, Solmsstraße 83, D-60486 Frankfurt am Main. Schweiz: Mattel AG, Kirchstrasse 24, CH-3097 Liebefeld. Österreich: Mattel Ges.m.b.H., Campus 21, Liebermannstraße A01 404, A- 2345 Brunn/Gebirge. Mattel Italy S.r.l. Via Turati 4, 20121 Milano, Italy. Servizio assistenza clienti: Customersrv.italia@mattel.com - Numero verde 800 11 37 11. Mattel España, S. A. Anibau 200 pl. 9, 08036 Barcelona. cservice.spain@mattel.com Tel: +34 933 06 79 00 http://www.service.mattel.com/es. Hong Kong: Kids Kingdom Limited, Room 1908-9, Gala Place, 56 Dundas Street, Mongkok, Kowloon, Hong Kong. Customer Care line: (852)2782-0766. Taiwan: Chickabiddy Company Limited, 5/F, No. 186, Section 4, Nanjing East Road, Taipei 10595, Taiwan. Customer Care line: (02)2578-1188. Mainland China: Mattel Barbie (Shanghai) Trading Co., Ltd. Units 4701-4711, 47F, 2 Grand Gateway, 3 Hong Qiao Road, Shanghai, 200030, P.R.C. Customer Care line: 400-819-8658. Diimport & Diedarkan Oleh: Mattel Continental Asia Sdn Bhd. Level 19, Tower 3, Avenue 7, No. 8 Jalan Kerinci, Bangsar South, 59200 Kuala Lumpur, Malaysia. Mattel South Africa (PTY) LTD. Office 102 13, 30 Melrose Boulevard, Johannesburg 2196. Dystrybutor: Mattel Poland Sp. z o.o., Budynek Skyliner 31 p., ul. Prosta 67, 00-838 Warszawa, Polska. Mattel Australia Pty. Ltd., 658 Church St., Richmond, Victoria, 3121. Consumer Advisory Service - 1300 135 312. Mattel AEBE, Εθνάρχου Μακαρίου 1, Κτήριο Κ-2, ΤΚ 17561, Παλαιό Φάληρο. Mattel Oyuncakçılık Tic. Ltd. Şti. İçerenköy Mah., Umut Sokak No: 10 - 12, Quick Tower kat:2 içkapı no:15 Ataşehir 34752, İstanbul, Türkiye. Tel: 0216 570 75 00. Импортёр/Уполномоченная организация: ООО "МАТТЕЛ" Российская Федерация, 105120 Москва, 2-й Сыромятинский переулок 1; +7 495 287 79 39. Mattel Czech Republic s.r.o., The Forum, Václavské nám. 19, 11000 Praha 1. Mattel, 333 Continental Boulevard, El Segundo, CA 90245, USA. Consumer Services: 1-800-465-MEGA (6342). Mattel Canada Inc., Mississauga, Ontario L5R 3W2. Consumer Services: You may call us free at/ Composez sans frais le 1-800-524-8697. Importado y distribuido por Mattel de México, S.A. de C.V., Miguel de Cervantes Saavedra No. 193, Pisos 10 y 11, Col. Granada, Alcaldía Miguel Hidalgo, C.P. 11520, México, Ciudad de México. R.F.C. MME-920701-NB3. Tels: 59-05-51-00 Ext. 5206 ó 01-800-463-59-89. Mattel Chile S.A., Pte. Riesco 5561, Of. 203-204 PS2. Las Condes, Santiago. Servicio al consumidor Venezuela: Tel: 0-800-100-9123. Mattel Argentina, S.A., Av. Libertador 1000, Piso 11 - Oficinas 109 y 111, Pisco Viejo - Prov. Buenos Aires. Tel.: 0800-666-3373. Mattel Colombia, S.A., Calle 123#7-07 P5, Bogotá. Mattel Perú, S.A., Av. Juan de Arona # 151, Centro Empresarial Juan de Arona, Torre C, Piso 7, Oficina 704, San Isidro, Lima 27, Perú. RUC: 20248553865. Reg. Importador: 02350-12-JUE-DIGESA. Tel: 0800-54744. E-mail Latinoamérica: servicio.clientes@mattel.com. Mattel do Brasil Ltda.- CNPJ : 54.558.002/0001-20 - Rua Verbo Divino, 1488 - 2º. Andar - 04719-904 - Chácara Santo Antônio - São Paulo - SP - Brasil. Serviço de Atendimento ao Consumidor: Contato: https://faleconosco.mattel.com.br/Contato. E-mail: sac.matteldobrazil@mattel.com.

©2023 Pokémon. ©1995–2023 Nintendo / Creatures Inc. / GAME FREAK inc. TM, ®, and character names are trademarks of Nintendo.

©2023 Pokémon. ©1995–2023 Nintendo/Creatures Inc./GAME FREAK inc. TM, ® et les noms des personnages sont des marques de Nintendo.





Discover & display the whole line
 Découvrez et exposez toute la gamme

Descubre toda la colección y crea una exposición
 Descubre e expõe toda a linha
 Alle Produkte der Reihe entdecken und präsentieren
 Собири и выстави всю серию



HTH74



HTH75



HTH76

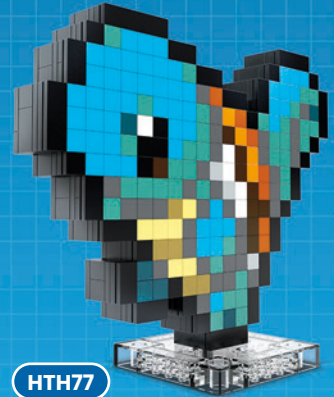

HTH77

MEGASHOWCASE.com

Set(s) sold separately and subject to availability. / Ensemble(s) vendu(s) séparément. Certains produits peuvent ne pas être commercialisés. / Se vende(n) por separado y está(n) sujeto(s) a disponibilidad. / Conjunto(s) vendido(s) em separado e sujeito(s) à disponibilidade. / Set in vendita separatamente, secondo disponibilità. / Das/Die Set(s) sind separat erhältlich. / Zestaw(y) sprzedawany(e) oddzielnie w zależności od dostępności. / Set(s) apart verkrijgbaar en afhankelijk van beschikbaarheid. / Набор(-ы) продаются отдельно, при наличии. / Sæt sælges separat og så længe lager haves. / Seten säljs separat så länge lagret räcker. / Settet/settene selges separat så langt lageret rekker. / Pakkaus/pakkaukset myydään erikseen, saatavuus voi vaihdella. / Το(α) σετ πωλούνται ξεχωριστά και ανάλογα με τη διαθεσιμότητα. / Setler ayrı olarak satılır ve stoklarla sınırlıdır. / Set (sety) se prodává (prodávají) samostatně dle aktuální nabídky. / Súprava/-y sa predáva(jú) samostatne a podľa dostupnosti. / A készlet(ek) külön kapható(k), az elérhetőség változhat. / セット商品は別売りになります。在庫状況は別途ご確認お願いします。 / 每套单独发售，按供货情况决定。

Mattel Canada Inc. Mississauga, Ontario L5R 3W2.
 MADE IN CHINA. FABRIQUÉ EN CHINE. FABRICADO NA CHINA. HECHO EN CHINA.
 ИЗГОТОВЛЕНО В КИТАЕ. ÇIN'DE ÜRETİLMİŞTİR. صنع في الصين

©2023 MEGA Brands &™ MEGA Brands.
 Printed in China / Imprimé en Chine
 AD-HTH75-01B



Inspirer les futures générations par le jeu.

™ & ©2023 Mattel.

1186 MJ, 1, NL



FR
 DONNEZ
 OU
 RECYCLEZ



ASSOCIATION



MAGASIN



DÉCHÈTERIE

Adresses sur quefairedemesdechets.fr

