



POKÉMON

BUILD YOUR PIXEL ART

CONSTRUIS TON ART PIXEL

**CONSTRUYE TU ARTE DE PÍXEL
CRIE SUA ARTE EM PÍXAEL**



**EEVEE
ÉVOLI**
EVOLI

HTH78



➤ BUILD YOUR PIXEL ART

Officially licensed Pokémon Pixel Art lets you build lasting memories with some of your favorite Pokémon.

➤ CONSTRUIS TON ART PIXEL

Le Pokémon Pixel Art sous licence officielle vous permet de construire des souvenirs inoubliables avec certains de vos Pokémon préférés.

➤ CONSTRUYE TU ARTE DE PÍXEL

Pokémon Pixel Art, oficialmente certificada, les permite crear recuerdos perdurables con algunos de sus Pokémon favoritos.

➤ CRIE SUA ARTE EM PIXAEL

A linha Pokémon Pixel Art oficialmente licenciada te deixa criar memórias duradouras com alguns de seus Pokémons favoritos.

➤ PIXELBILDER ERSTELLEN

Mit offiziell lizenzierter Pokémon Pixelkunst bleibende Erinnerungen an Lieblings-Pokémons gestalten.

➤ СОБЕРИ СВОЮ ПИКСЕЛЬНУЮ ФИГУРКУ

С лицензионной версией Pokémon Pixel Art вы сможете создать незабываемые моменты с вашим любимым Pokémon.

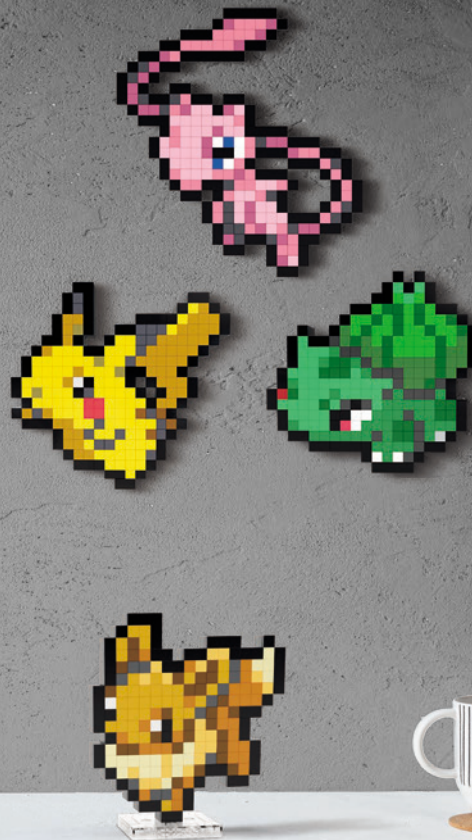

Set(s) sold separately and subject to availability. / Ensemble(s) vendu(s) séparément. Certains produits peuvent ne pas être commercialisés. / Se vende(n) por separado y está(n) sujeto(s) a disponibilidad. / Conjunto(s) vendido(s) em separado e sujeito(s) à disponibilidade. / Set in vendita separatamente, secondo disponibilità. / Das/Die Set(s) sind separat erhältlich. / Zestaw(y) sprzedawany(e) oddzielnie w zależności od dostępności. / Set(s) apart verkrijgbaar en afhankelijk van beschikbaarheid. / Набор(-ы) продаются отдельно, при наличии. / Sæt sælges separat og så længe lager haves. / Seten säljs separat så länge lagret räcker. / Settet/settene selges separat så langt lageret rekker. / Pakkaus/pakkaukset myydään erikseen, saatavuus voi vaihdella. / Το(α) σετ πωλούνται ξεχωριστά και ανάλογα με τη διαθεσιμότητα. / Setler ayrı olarak satılır ve stoklarla sınırlıdır. / Set (sety) se prodává (prodávají) samostatně dle aktuální nabídky. / Súprava/-y sa predáva(jú) samostatne a podľa dostupnosti. / A készlet(ek) külön kapható(k), az elérhetőség változhat. / セット商品は別売りになります。在庫状況は別途ご確認お願いします。 / تباع المجموعة أو المجموعات على حدة وتضع لتوافرها. / 每套单独发售，按供货情况决定。

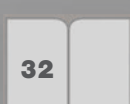
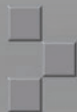
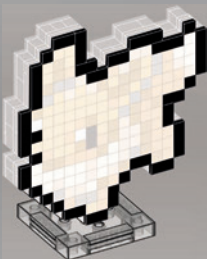
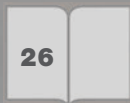
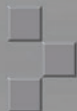
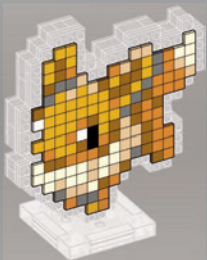
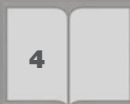
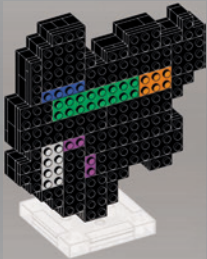



**GET INSTRUCTIONS ONLINE
INSTRUCTIONS DISPONIBLES
EN LIGNE**

CONSULTA LAS INSTRUCCIONES EN LÍNEA
OBTEN INSTRUÇÕES ONLINE
ANWEISUNGEN ONLINE ERHÄLTICH
ИНСТРУКЦИИ ДОСТУПНЫ ОНЛАЙН



megaunboxed.com

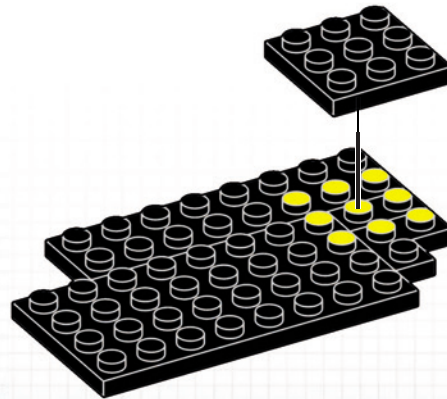
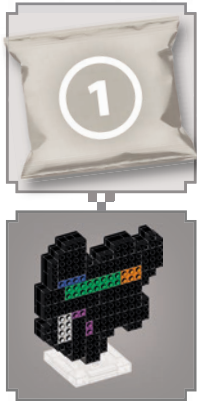

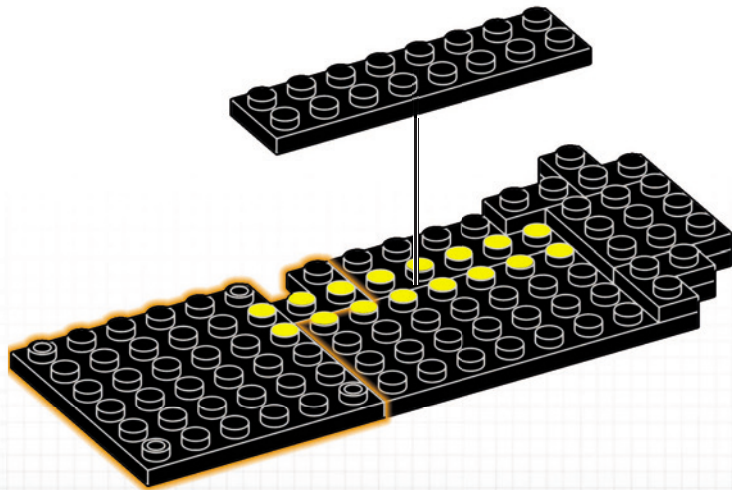
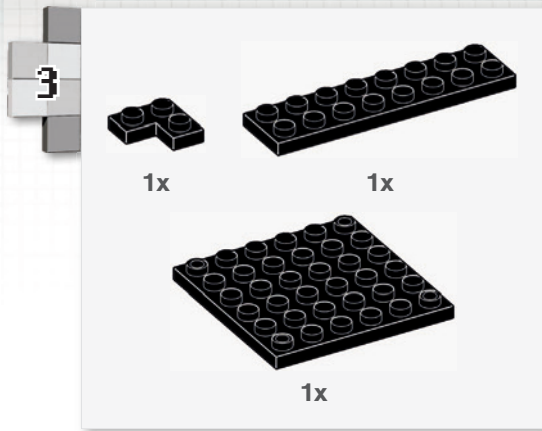
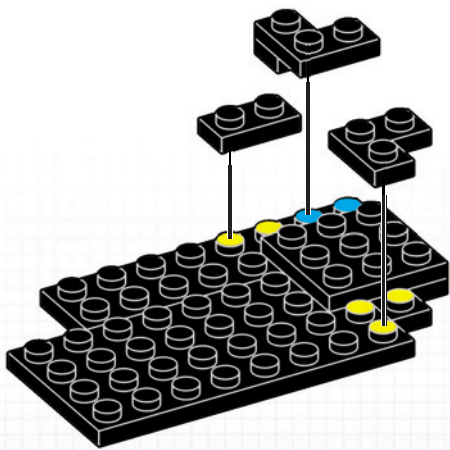
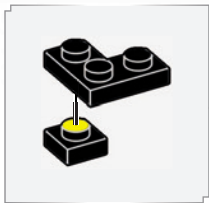
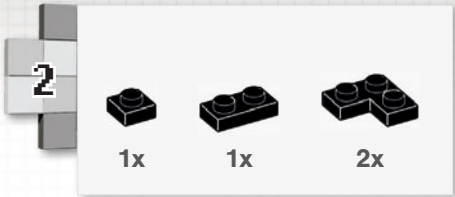

4



1x



1x



1x



1x



1



2

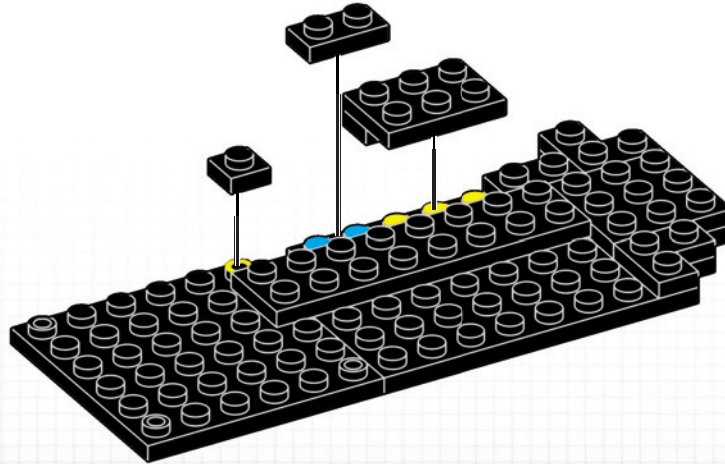

6



1x



1x



2x

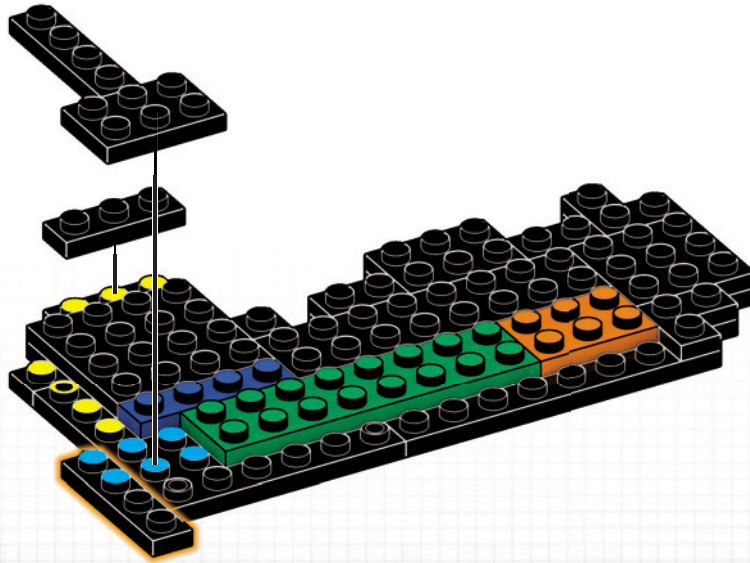

7



1x



1x



1x



2x



1x

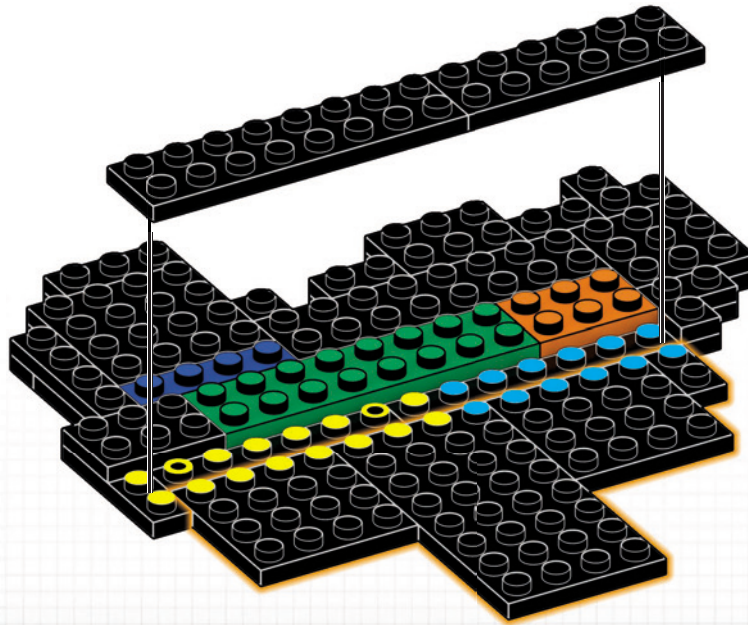

8



1x



2x



1x



2x



1x



1x

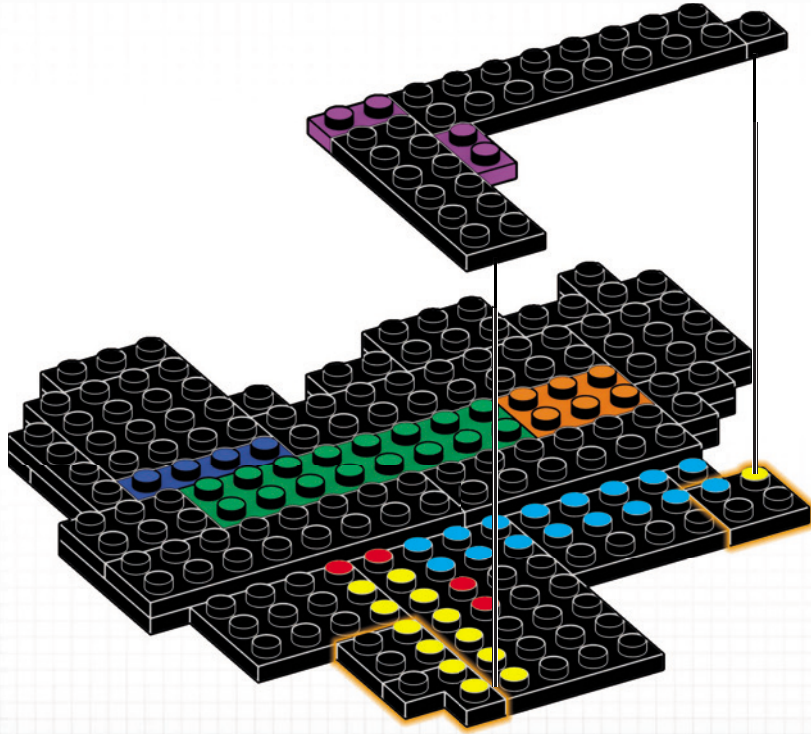

9



3x

1x

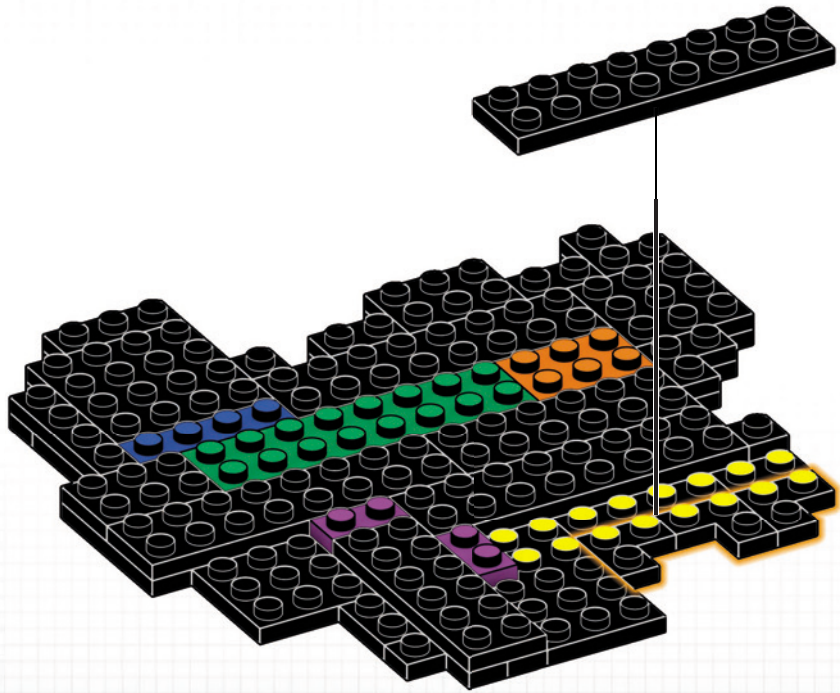

10



1x



1x



1x



1x

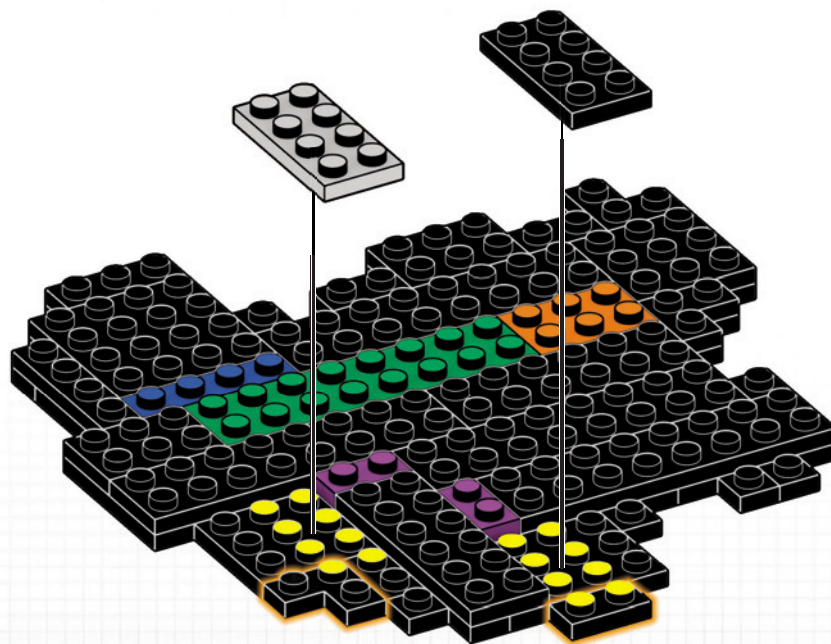

11



4x



3x

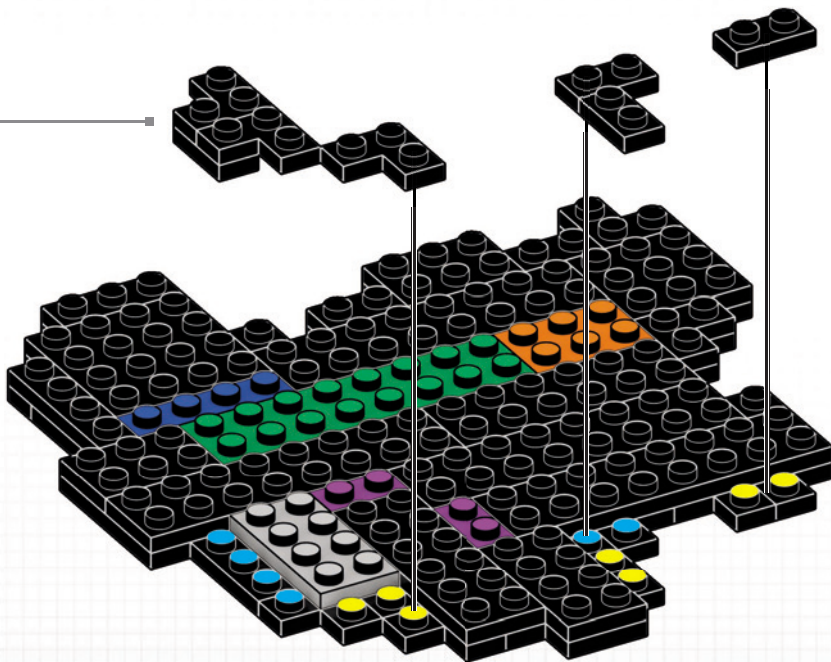
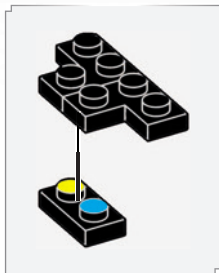
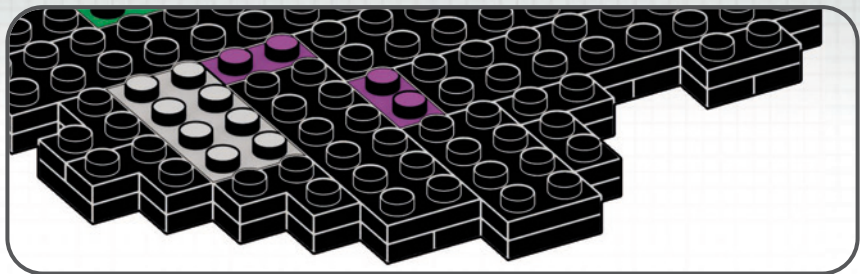



12



1x



6x

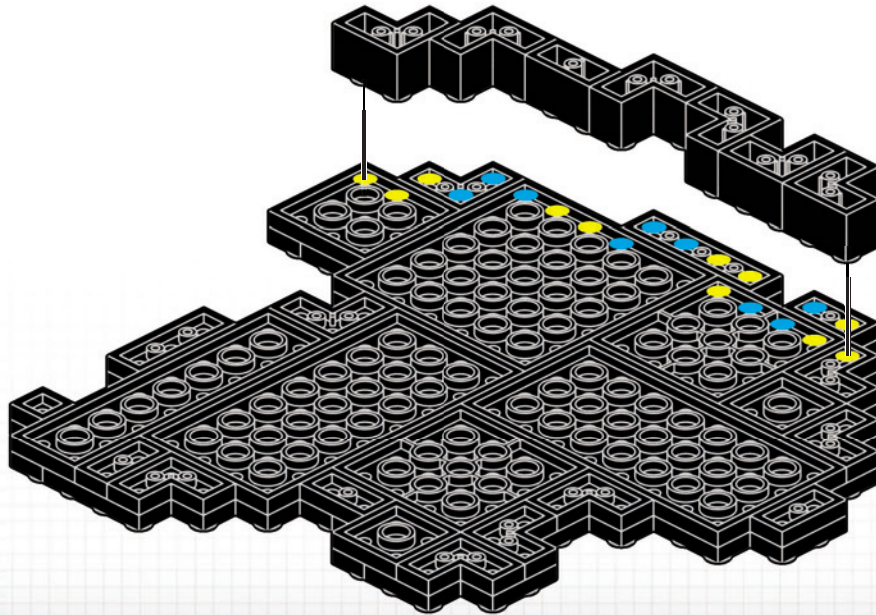

13



1x



2x



1x

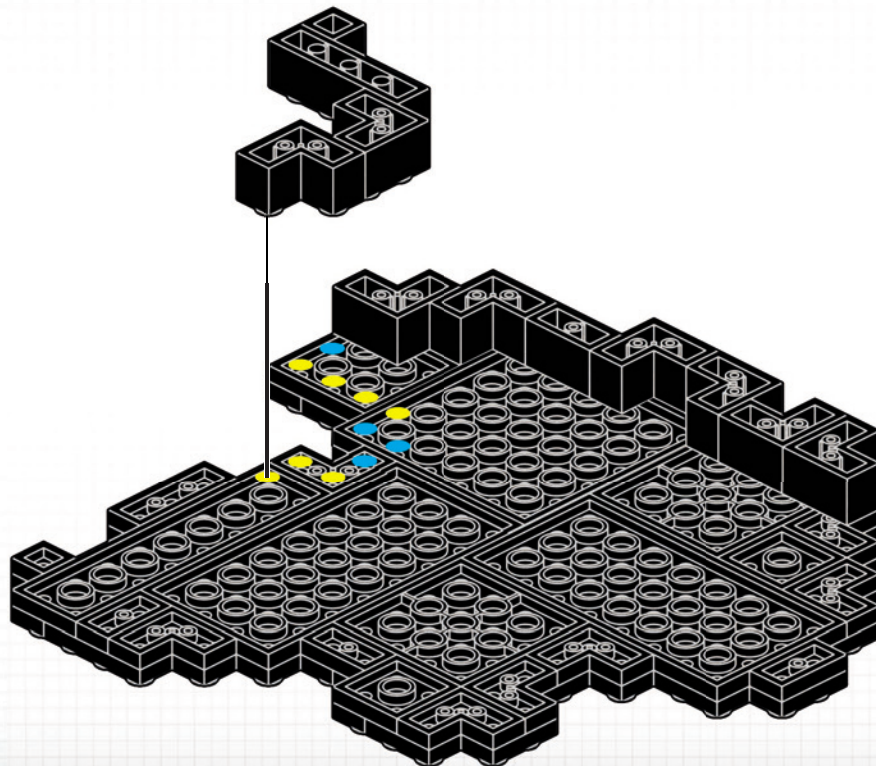

14



1x



3x



1x

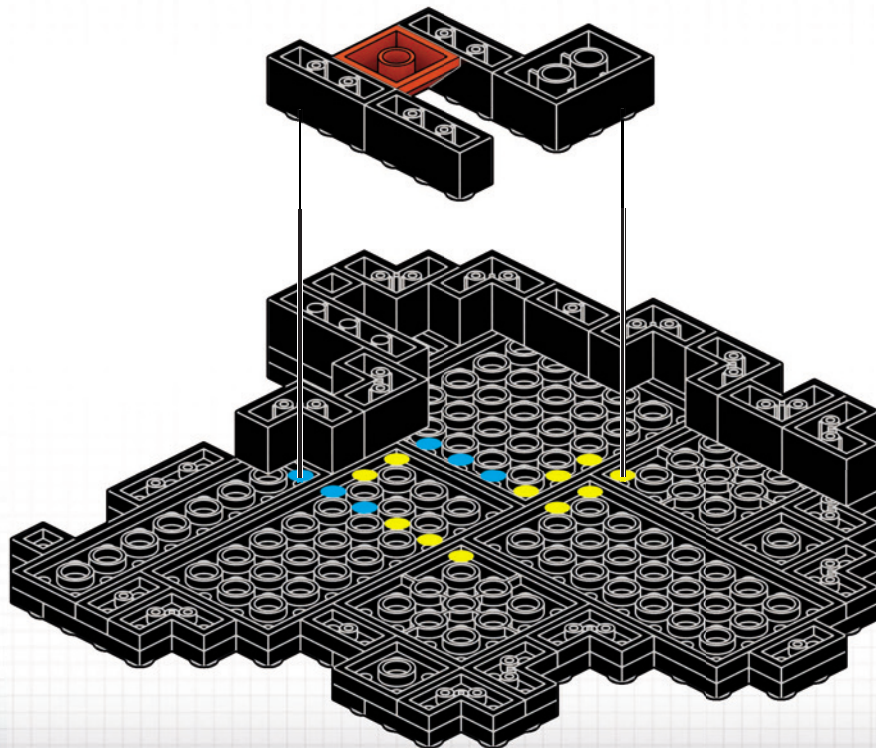

15



1x



5x



1x

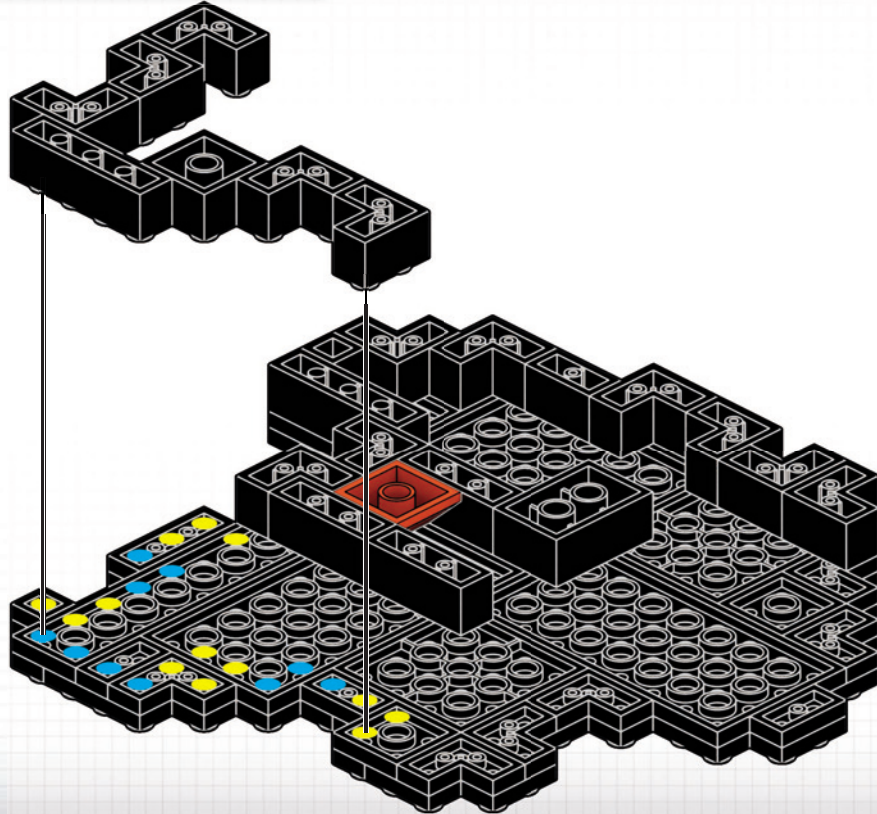

16



2x



1x



1x



1x

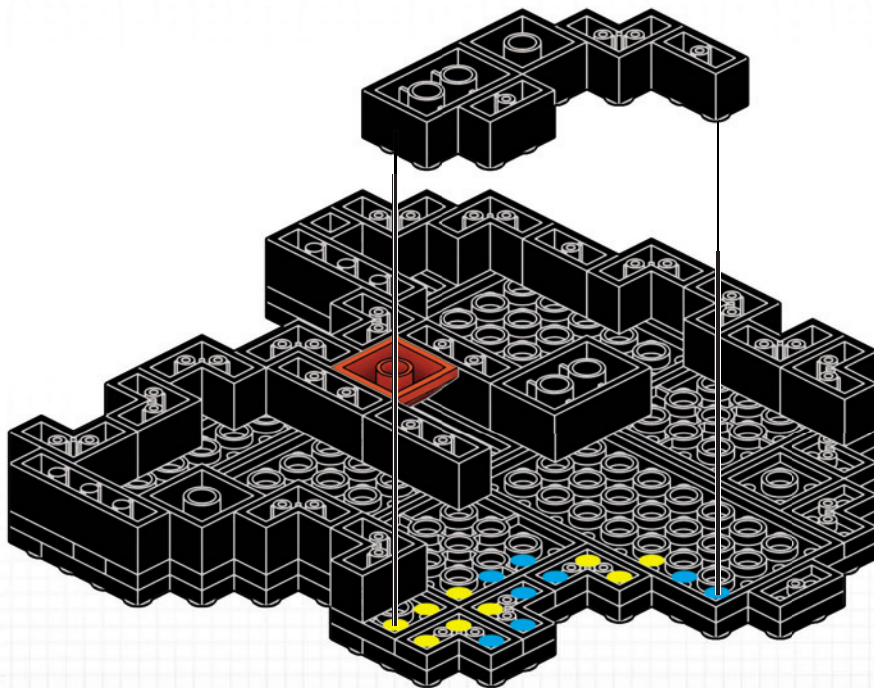

17



1x



1x



1x

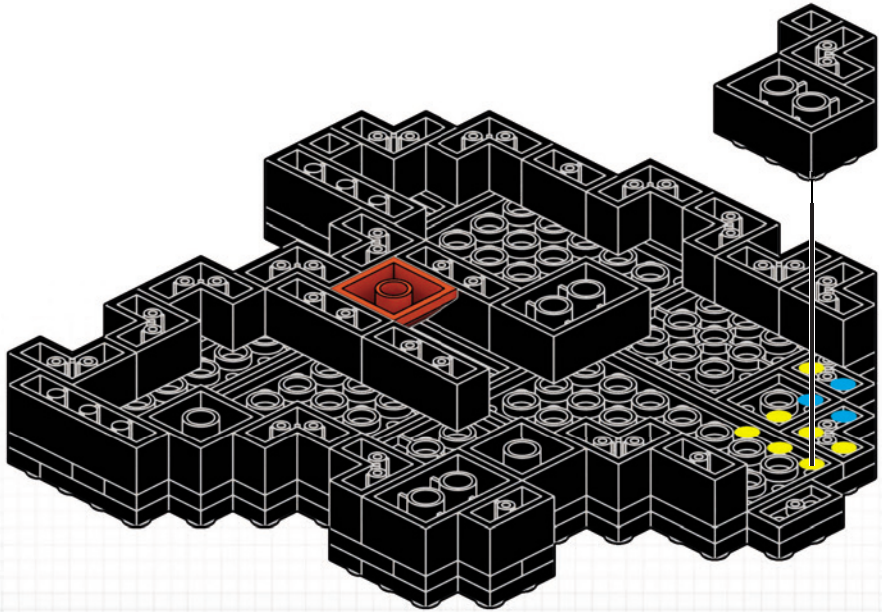

18



2x



1x

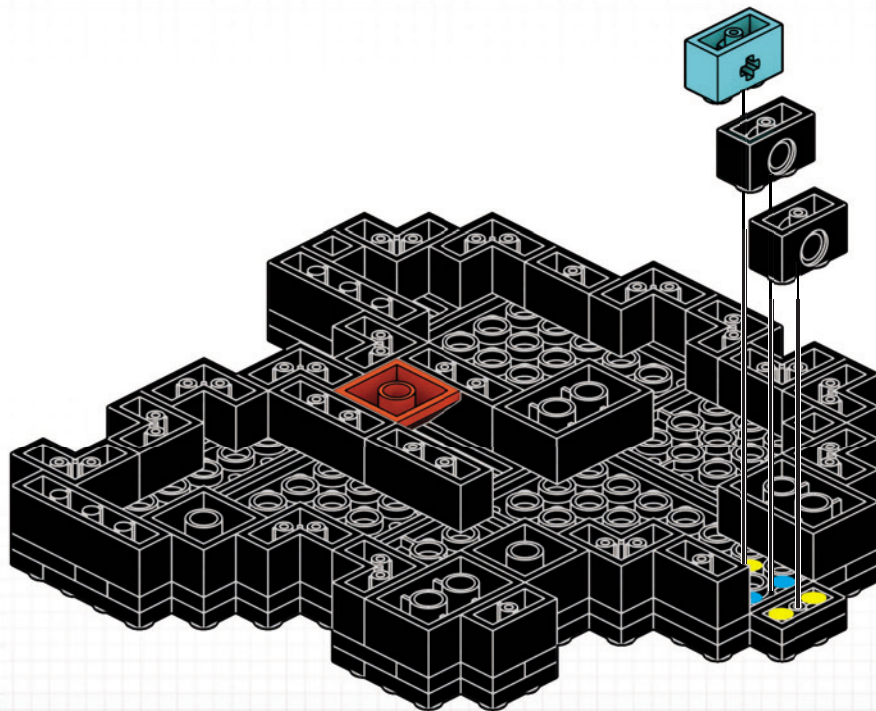

19



2x



2x



1x



1x

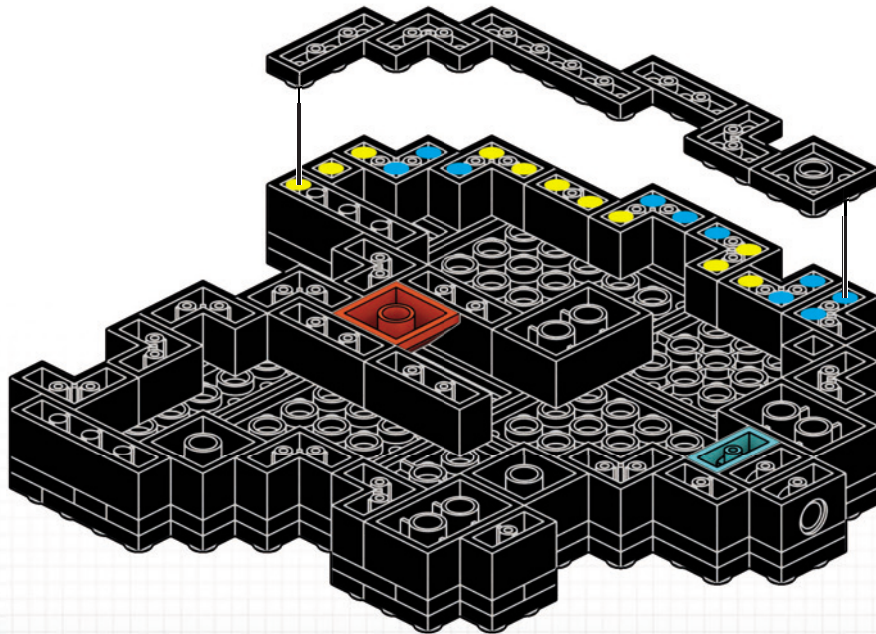

20



4x



1x



2x



1x



1x

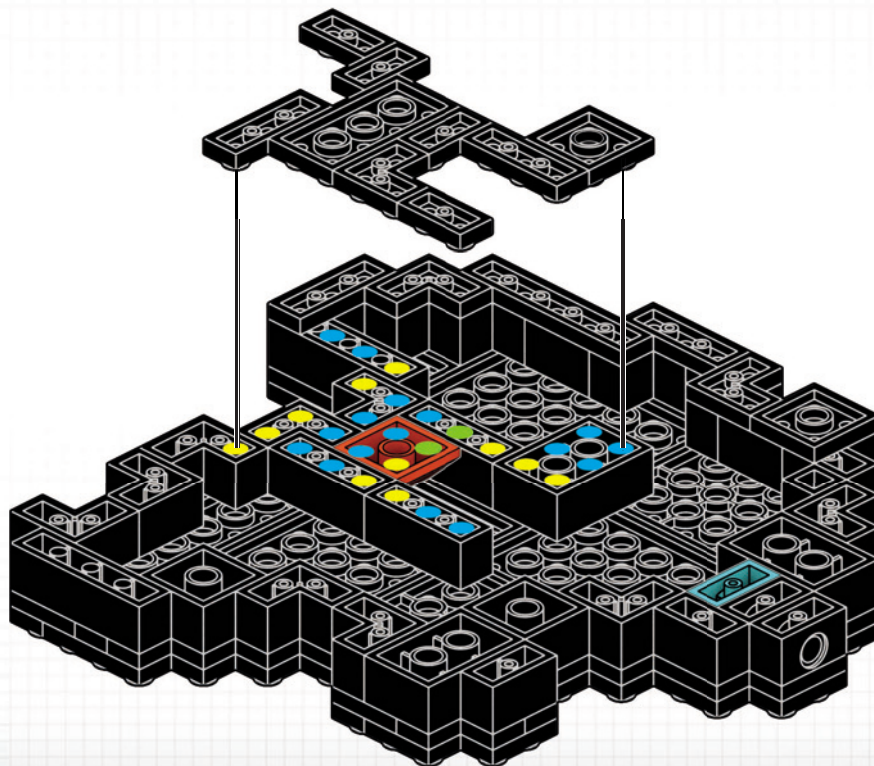

21



1x



2x



4x

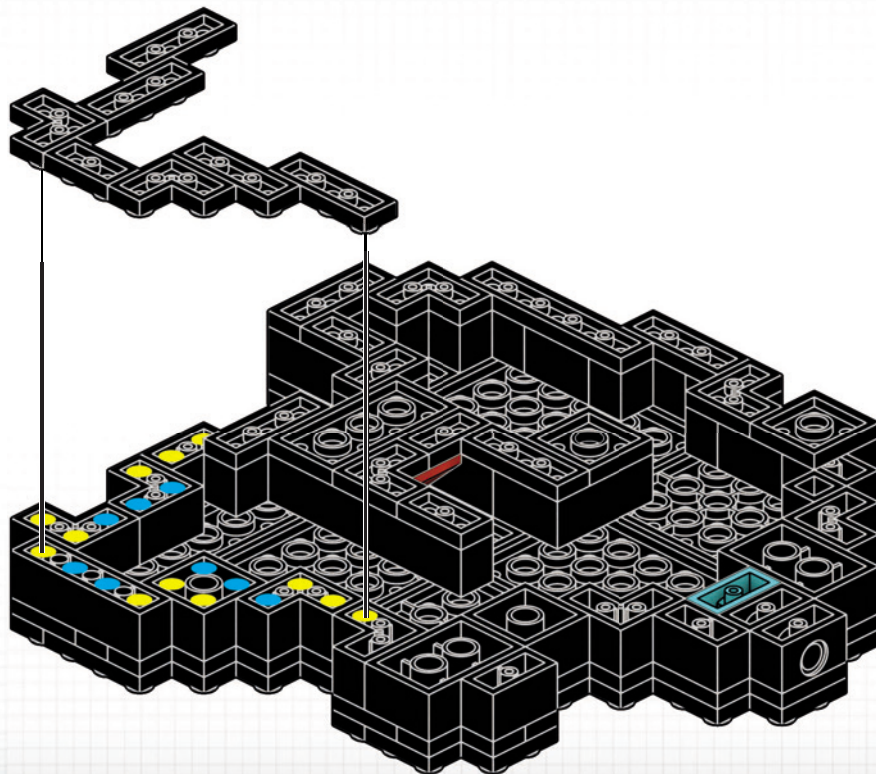

22



6x



1x

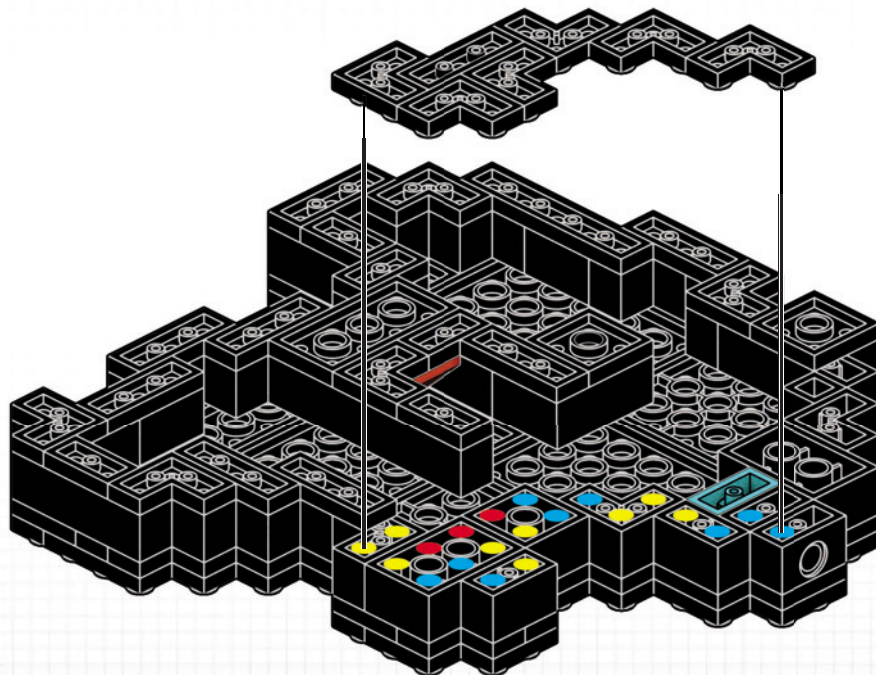

23



3x



2x

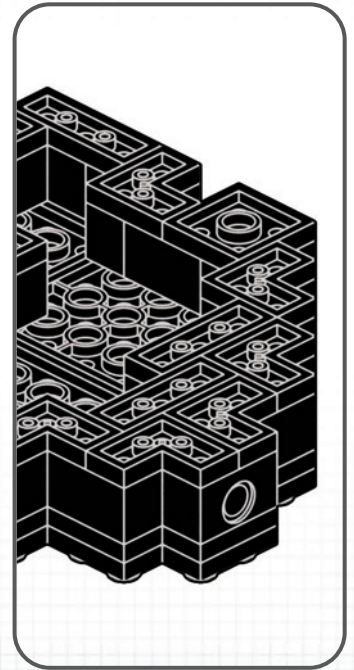
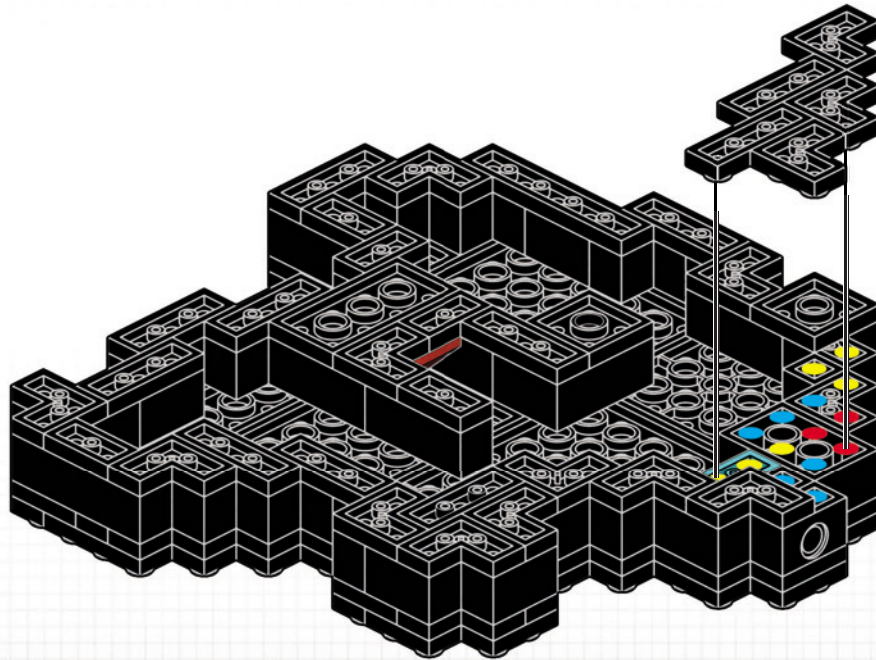



Building Tool Outil de construction

Herramienta de construcción
Bauwerkzeug
Ferramenta de montagem
Инструмент для конструирования

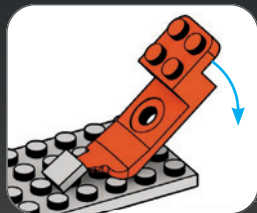

BUILD THE SWATCH TOOL. CONSTRUISEZ L'OUTIL ÉCHANTILLON.

CREA LA HERRAMIENTA DE MUESTRA.
CONSTRÓI A FERRAMENTA DE AMOSTRAS.
DAS MUSTERWERKZEUG ZUSAMMENBAUEN.
СОБЕРИТЕ ИНСТРУМЕНТ С ОБРАЗЦАМИ.

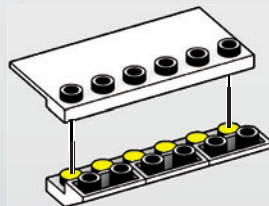

1

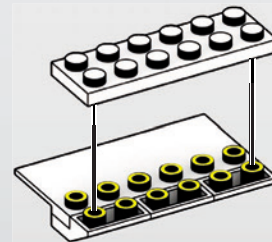

2

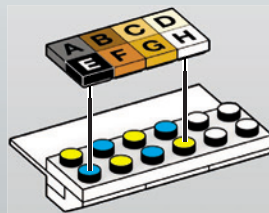

3

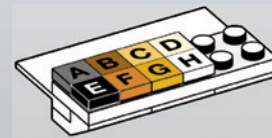

4



**USE THE SWATCH AS REFERENCE TO PLACE THE PIECES.
UTILISEZ L'ÉCHANTILLON COMME RÉFÉRENCE POUR PLACER LES PIÈCES.**

UTILIZA LA HERRAMIENTA DE MUESTRA COMO REFERENCIA PARA COLOCAR LAS PIEZAS.

COLOCA AS PEÇAS UTILIZANDO AS AMOSTRAS COMO REFERÊNCIA.

DAS MUSTER ALS REFERENZ ZUR ANORDNUNG DER TEILE VERWENDEN.

ИСПОЛЬЗУЙТЕ ИНСТРУМЕНТ С ОБРАЗЦАМИ, ЧТОБЫ ПОНИМАТЬ, КАК РАЗМЕЩАТЬ ДЕТАЛИ.



AFTER COMPLETING A LINE, USE THE TOOL TO STRAIGHTEN THE PIECES.
APRÈS AVOIR COMPLÉTÉ UNE LIGNE, UTILISEZ L'OUTIL POUR REDRESSER LES PIÈCES.

TRAS COMPLETAR UNA LÍNEA, UTILIZA LA HERRAMIENTA PARA ENDEREZAR LAS PIEZAS.
DEPOIS DE CONCLUÍRES UMA LINHA, UTILIZA A FERRAMENTA PARA ENDEREITAR AS PEÇAS.
NACH VOLLENDUNG EINER ZEILE DAS WERKZEUG ZUM GERADERICHTEN DER TEILE VERWENDEN.
КОГДА СОБЕРЕТЕ ЛИНИЮ, ИСПОЛЬЗУЙТЕ ИНСТРУМЕНТ ДЛЯ ВЫРАВНИВАНИЯ ДЕТАЛЕЙ.

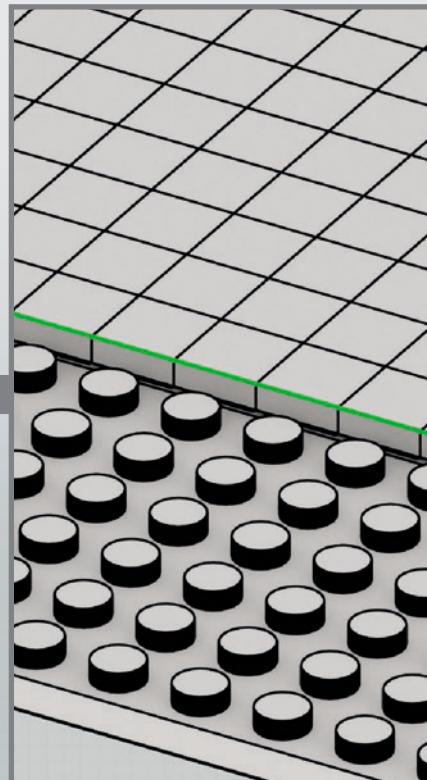
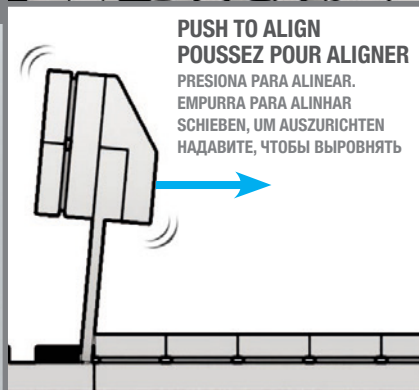
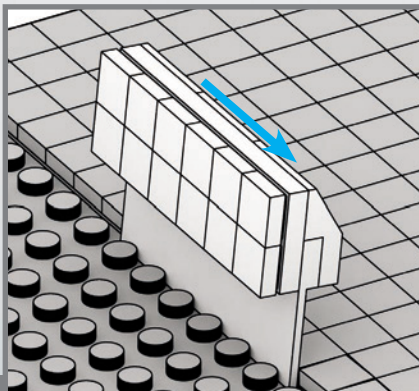
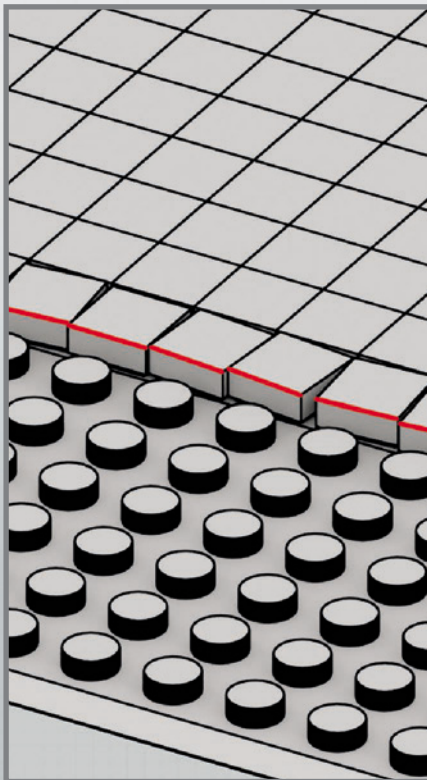

USING THE LETTERS AS YOUR GUIDE, EMPTY THE BAGS INTO THE CORRESPONDING SECTIONS OF THE TRAY.
EN UTILISANT LES LETTRES COMME GUIDE, VIDEZ LES SACS DANS LES SECTIONS CORRESPONDANTES DU PLATEAU.

UTILIZA LAS LETRAS COMO GUÍA Y VACÍA LAS BOLSAS EN LAS SECCIONES CORRESPONDIENTES DE LA BANDEJA.

UTILIZANDO AS LETRAS COMO ORIENTAÇÃO, ESVAZIA OS SACOS NAS SEÇÕES CORRESPONDENTES DO TABULEIRO.

DIE BEUTEL ANHAND DER BUCHSTABEN IN DIE ENTSPRECHENDEN ABSCHNITTE DES TABLETS ENTLEREEN.

ВЫСЫПЬТЕ СОДЕРЖИМОЕ ПАКЕТИКОВ В СООТВЕТСТВУЮЩИЕ ОТДЕЛЕНИЯ ПОДСТАВКИ ПО БУКВАМ.





FOLLOW THE GRID TO
PLACE THE PIECES.

SUIVEZ LA GRILLE POUR
PLACER LES PIÈCES.

SIGUE LA CUADRÍCULA PARA
COLOCAR LAS PIEZAS.

COLOCA AS PEÇAS DE ACORDO
COM A GRELHA.

DIE TABELLE ZUR ANORDNUNG
DER TEILE BEFOLGEN.

ОРИЕНТИРУЙТЕСЬ НА СЕТКУ,
РАЗМЕЩАЯ ДЕТАЛИ.

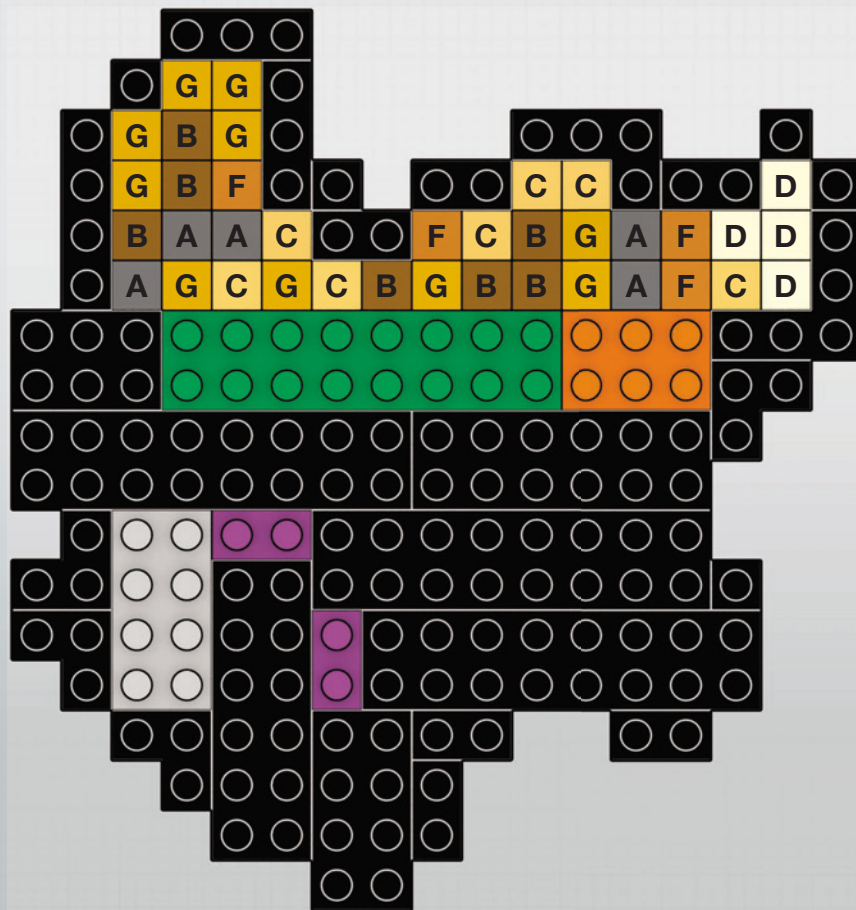

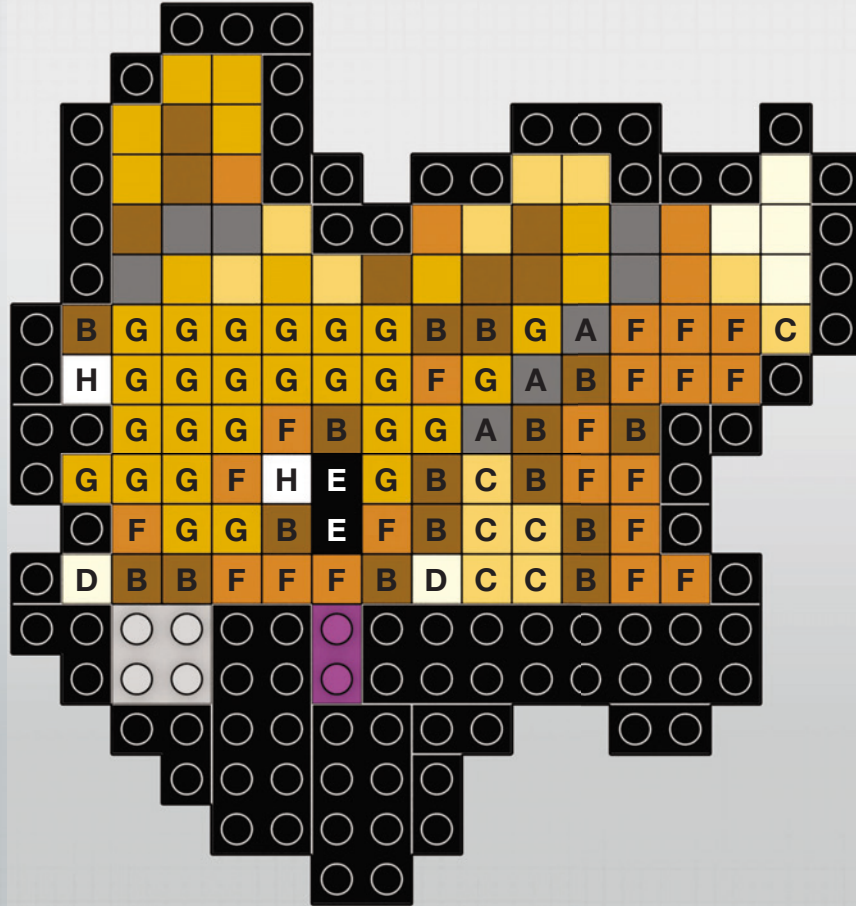

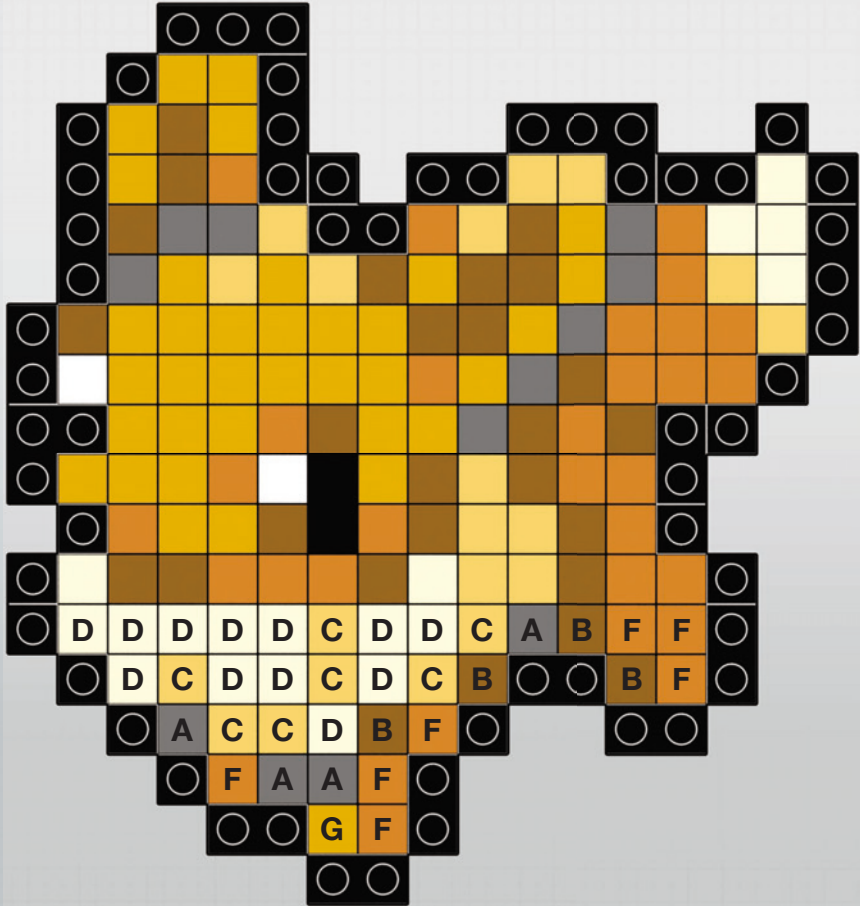



24

		
1x	1x	2x

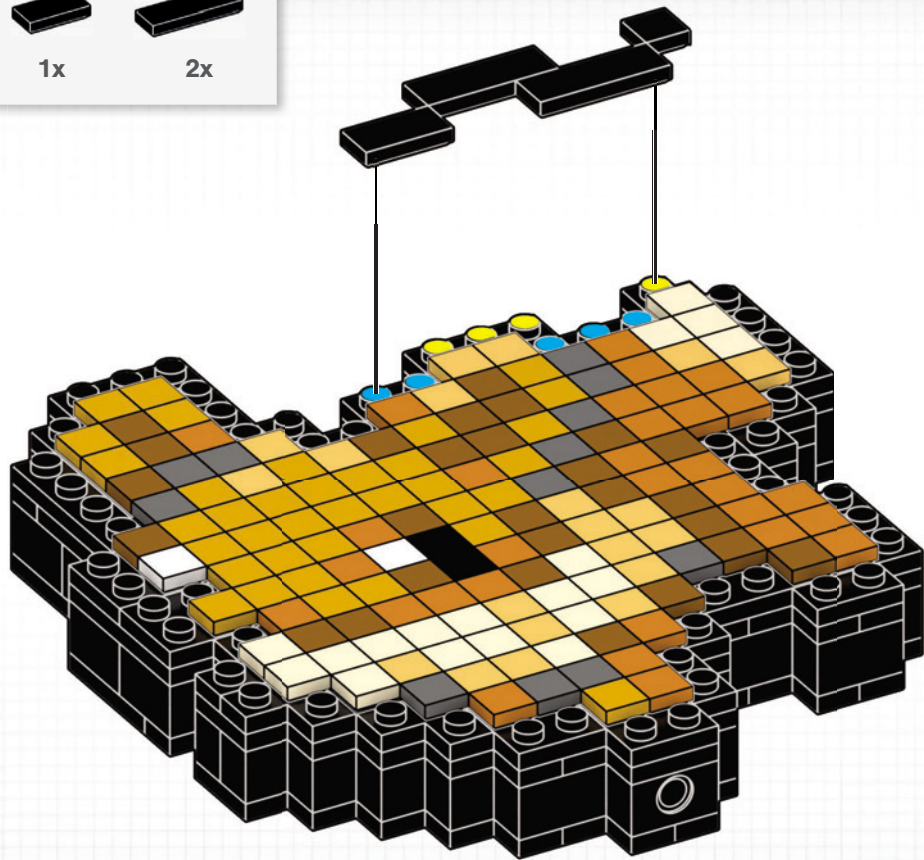

25



1x



2x



1x

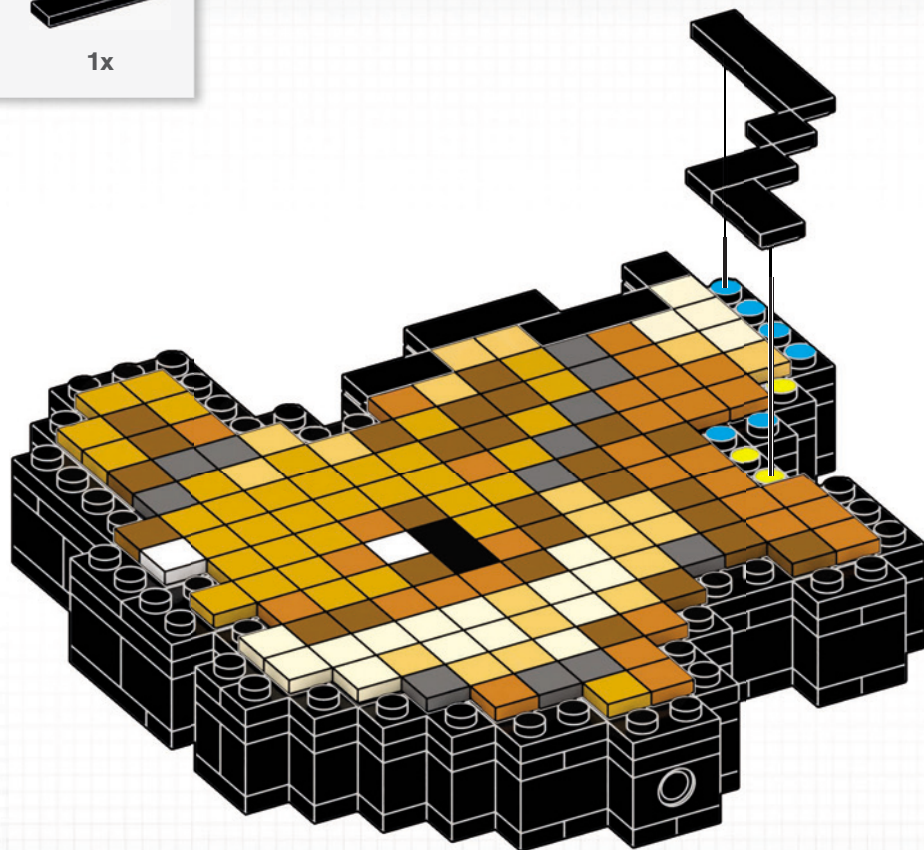

26



1x



3x



1x



1x

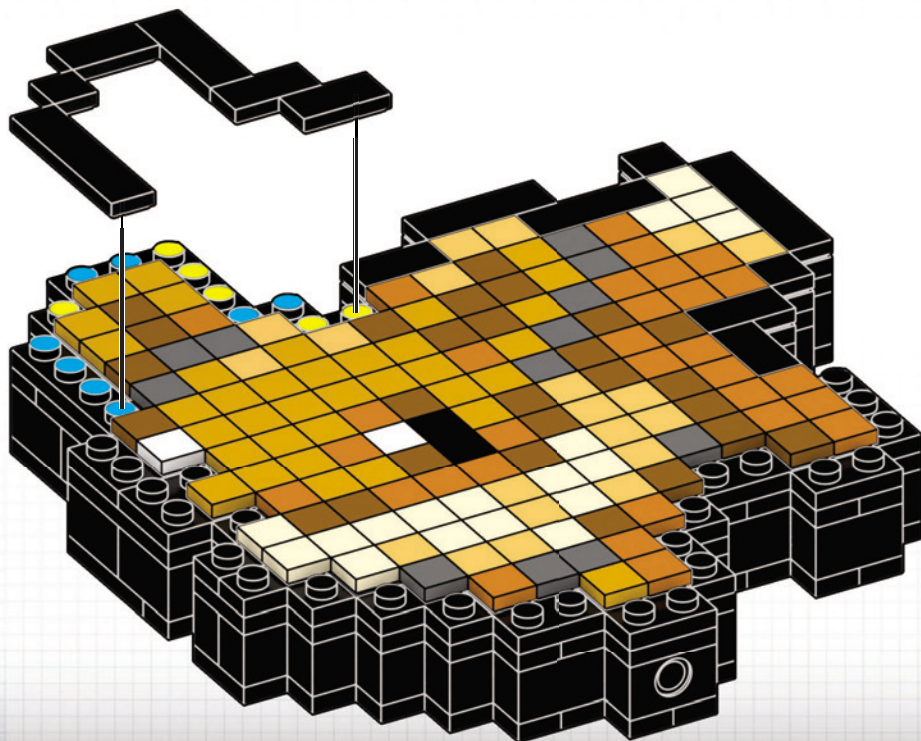

27



5x



1x



1x

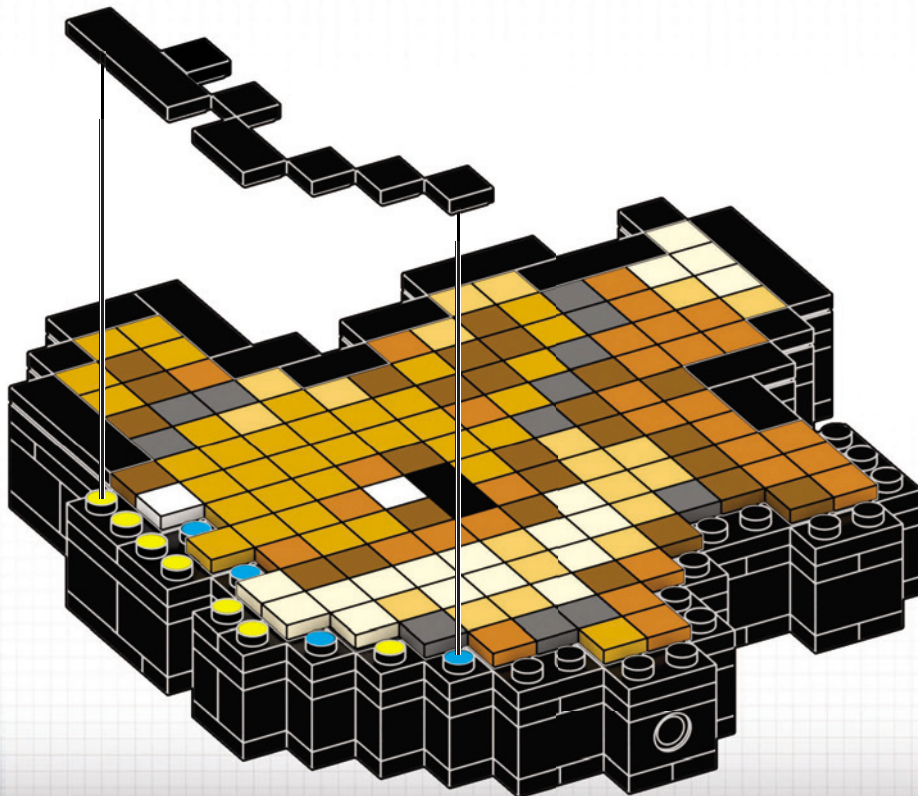

28



1x



5x



1x

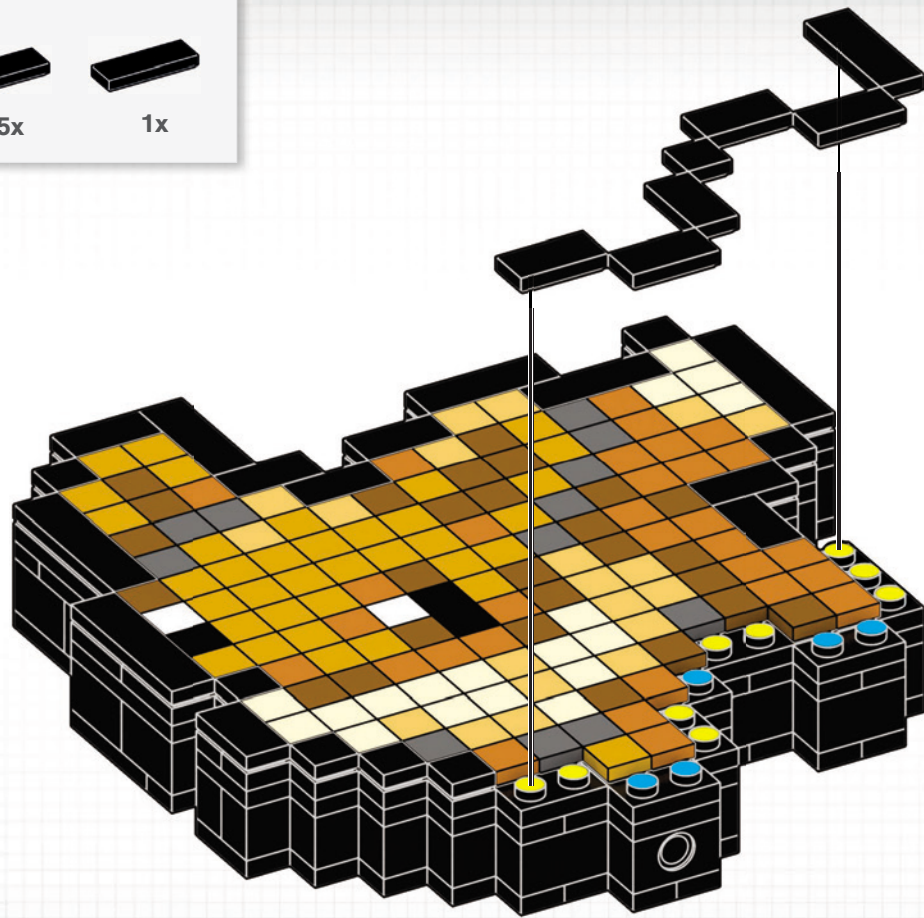

1

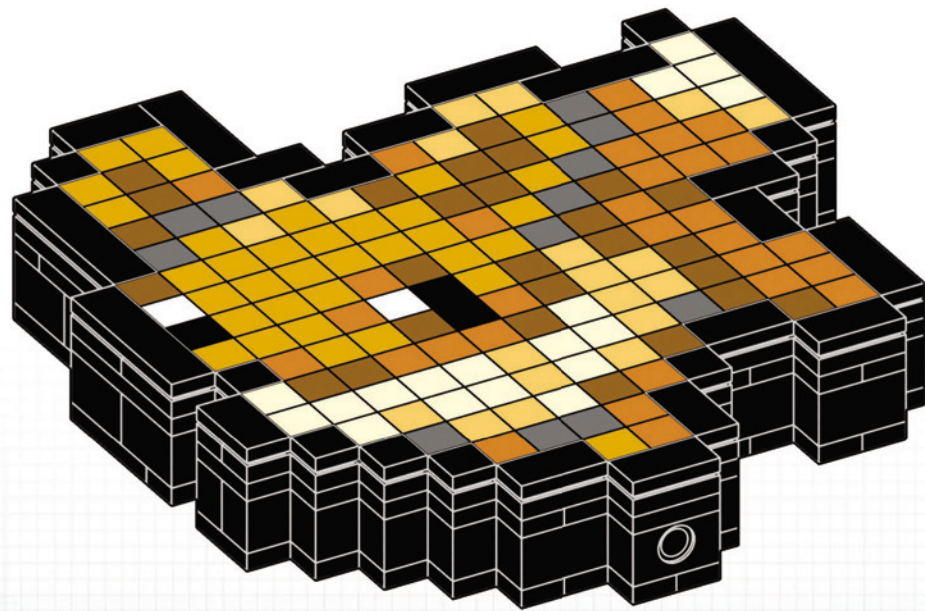

2

29

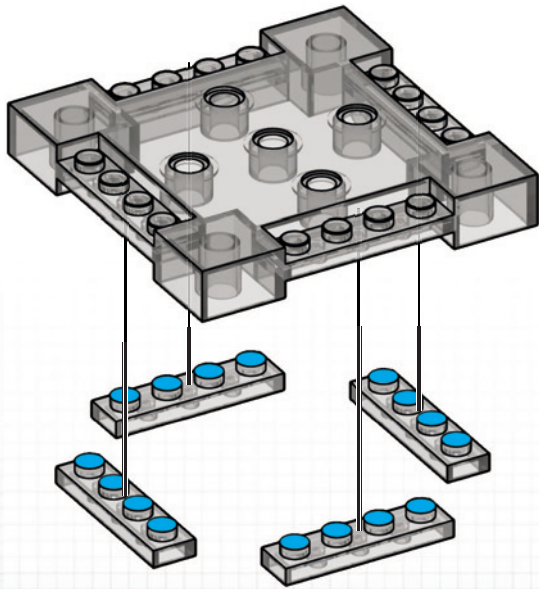
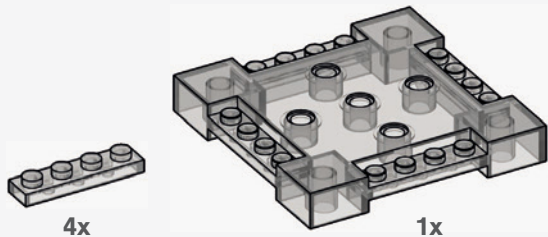

30

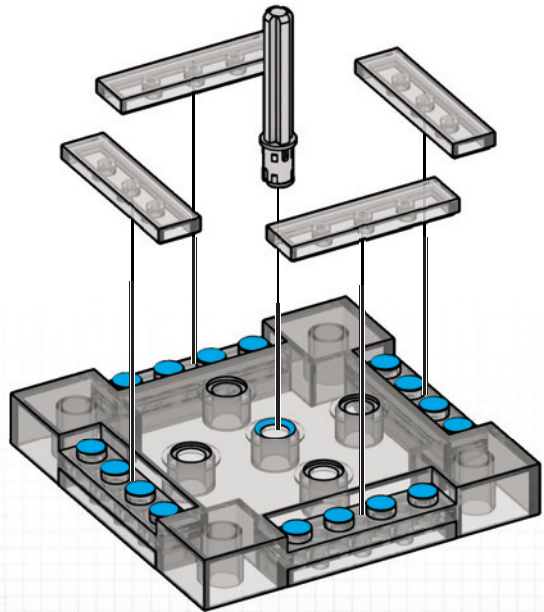

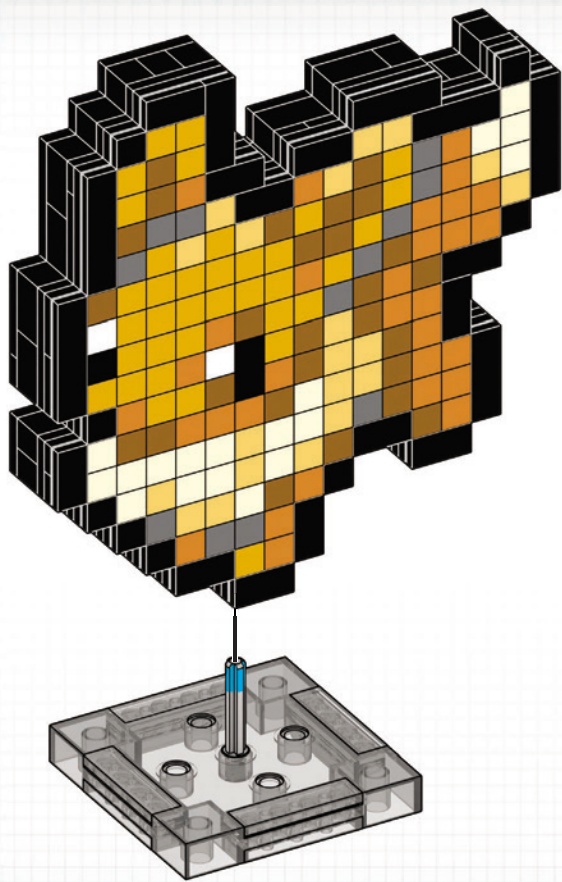

1

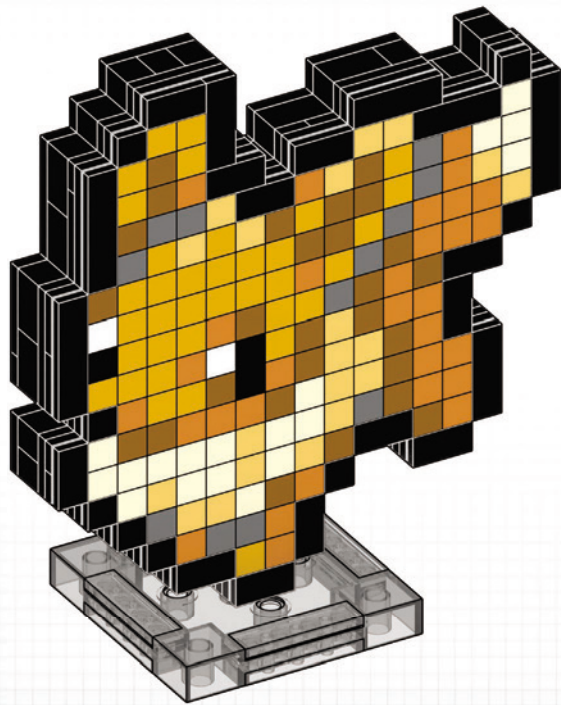

2

**ATTACH IT TO THE BASE FOR DISPLAY
FIXEZ-LE À LA BASE POUR L'EXPOSER**

COLOCA LA FIGURA NA BASE PARA EXPONERLA.
ENCAIXA A FIGURA NA BASE PARA EXPÔ-LA
ZUM AUSSTELLEN AM SOCKEL BEFESTIGEN
УСТАНОВИТЕ ФИГУРКУ НА ОСНОВАНИЕ, ЧТОБЫ ПОСТАВИТЬ ЕЕ



**USE THE HOOK TO MOUNT IT ON THE WALL
UTILISEZ LE CROCHET POUR LE FIXER AU MUR**

UTILIZA EL GANCHO PARA COLGARLO EN LA PARED
UTILIZA O GANCHO PARA PRENDÊ-LA NA PAREDE
MITHILFE DES HAKENS AN DER WAND BEFESTIGEN
ИСПОЛЬЗУЙТЕ КРЮЧОК ДЛЯ КРЕПЛЕНИЯ НА СТЕНУ



1

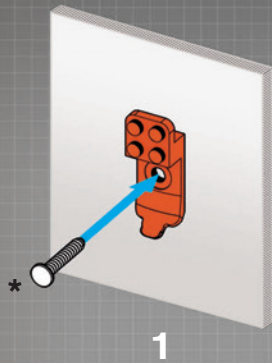

2

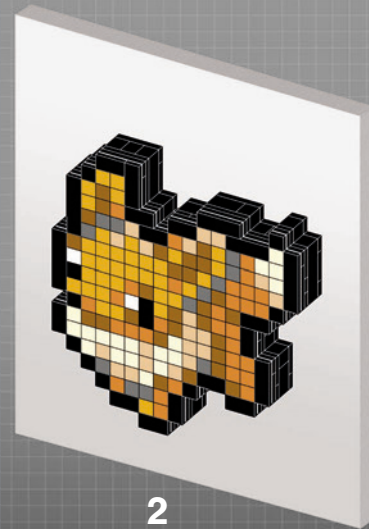
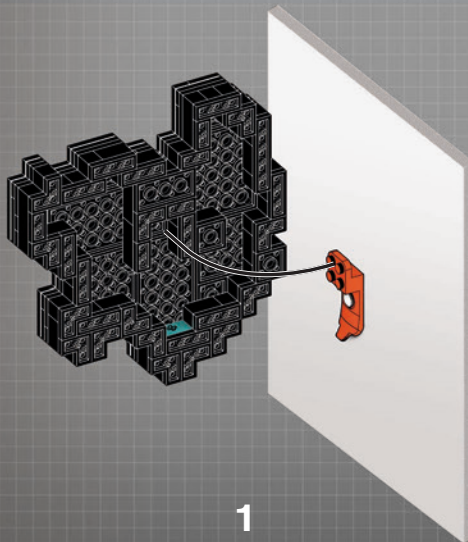

*Hardware not included / Matériel d'installation non inclus. / Equipo no incluido. / Hardware não incluído. / Componenti hardware non inclusi. / Hardware nicht enthalten. / Elementy montażowe nie znajdują się w zestawie. / Hardware niet inbegrepen. / Оборудование не входит в комплект. / Hardware medfølger ikke. / Skruvar och verktyg ingår inte. / Fastvare følger ikke med. / Tarvikkeet eivät sisälly pakkaukseen. / Δεν περιλαμβάνονται εργαλεία. / Donanim ürüne dahil değildir. / Nářadí není součástí balení. / Hardvører nie je súčasťou balenia. / A hardver nem tartozék. / ハードウェアは商品に含まれていません。 / . الاجهزة غير متضمنة / 不含硬件

1x
AS-HTH78-01



1x
AS-HTH78-02



1x
AS-HTH78-03



1x
AS-HTH78-04



1x
AS-HTH78-05



1x
AS-HTH78-06



1x
AS-HTH78-07



1x
AS-HTH78-08



12x
AM07223BDG



27x
AM07223MY



20x
AM07223BAB



18x
AM07223WC



11x
AM07223F



31x
AM07223BAA



36x
AM07223AZH



2x
AM07223E



3x
AM03328F



2x
AM01086F



12x
AM22501F



14x
AM09393F



2x
AM09393AEN



27x
AM15484F



4x
AM03773F



3x
AM09013F



2x
AM79877F



1x
AM80259ASU



15x
AM17153F



2x
AM09023F



3x
AM18223E



1x
AM10273MCX



13x
AM01314F



4x
AM80966F



3x
AM16384F



2x
AM03772F



1x
AM03772JU



3x
AM03873F



2x
AM81163F

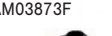

2x
AM09593F



1x
AM09593B



4x
AM09593W



3x
AM09838F



4x
AM09838W



1x
AM80876BLG



2x
AM01087F



2x
AM09493F

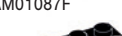

1x
AM09493BLG



3x
AM17054F



1x
AM07475F



1x
AM81906MCX



2x
AM01480F



1x
AM01480E



1x
AM72333E



1x
AM74681F



5x
AM08483F

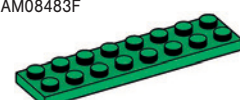

1x
AM08483BMG



2x
AM17845F

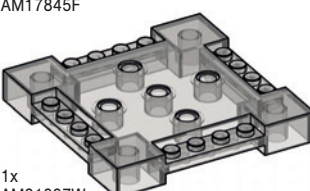

1x
AM81997W

Missing pieces?
Pièces manquantes?
 ¿Partes faltantes? • Perdeu peças?
 Fehlen Teile? • Не хватает деталей?

support.megabrand.com

Please read these instructions carefully before first use and keep them for future reference.
Il est recommandé de lire attentivement ce feuillet avant la première utilisation et de le conserver pour référence future.
Leer estas instrucciones cuidadosamente antes de la primera utilización y guardarlas para referencia futura.

Leia as instruções antes do primeiro uso e guarde-as para futura referência.

Leggere le istruzioni prima di cominciare ad usare il gioco e conservarle per referenze future.

Die Gebrauchsanleitung bitte durchlesen und aufbewahren.

Proszę uważnie przeczytać instrukcję obsługi przed pierwszym użyciem, a następnie zachować ją na przyszłość.

Wij raden u aan deze handleiding zorgvuldig te lezen en te bewaren voor eventuele raadpleging op een later tijdstip.

Внимательно прочитайте инструкцию перед первым использованием и сохраните ее для дальнейшего использования.

Vær venlig at læse disse instruktioner omhyggeligt inden ibrugtagen og opbevar dem til fremtidigt brug.

Läs noggrant igenom dessa instruktioner innan du använder produkten för första gången och spara dem för ev framtida frågor.

Les disse instruksjonene nøye før første gangs bruk, og ta vare på dem for fremtidige oppslag.

Lue nämä ohjeet huolellisesti ennen ensimmäistä käyttöä ja säilytä ne myöhemmää tarvetta varten.

Διαβάστε προσεκτικά τις οδηγίες πριν από τη χρήση και κρατήστε τις για μελλοντική αναφορά.

İlk kullanımdan önce talimatları dikkatlice okumanızı ve bu bilgileri ileride tekrar bakabilmek için saklamanızı öneririz.

Před prvním použitím si pozorně přečtete pokyny a uschovejte je pro budoucí použití.

Pred prvým použitím si pozorne prečítajte návod a uschovajte ho pre prípad potreby.

Olvasva el első használat előtt, és őrizze meg az útmutatót, mert a későbbiekben is felhasználható, fontos információkat tartalmaz.

初めてご使用になる前に、この説明書をよくお読みください。また、本書は将来いつでも参照できるように保管してください。

يجب قراءة هذه التعليمات بعناية قبل الاستخدام والإحتفاظ بها للعودة إليها مستقبلاً.

第一次使用前，请仔细阅读本说明书并保留以备将来参考。

Mattel Europa B.V., Gondel 1, 1186 MJ Amstelveen, Nederland. Mattel U.K. Limited, The Porter Building, 1 Brunel Way, Slough SL1 1FQ, UK. Mattel France, Parc de la Cerisaie, 1/3/5 allée des Fleurs, 94260 Fresnes Cedex. N° Cristal 0969 36 99 99 (Numéro non surtaxé) ou www.lesjouetsmattel.fr Mattel Belgium N.V. De Kleetlaan 4, 1831 Machelen (Diegem) Belgium. Deutschland : Mattel GmbH, Solmsstraße 83, D-60486 Frankfurt am Main. Schweiz: Mattel AG, Kirchstrasse 24, CH-3097 Liebefeld. Österreich: Mattel Ges.m.b.H., Campus 21, Liebermannstraße 401 404, A- 2345 Brunn/Gebrige. Mattel Italy Srl, Via Turati 4, 20121 Milano, Italy. Servizio assistenza clienti: Customersrvitalia@mattel.com - Numero verde 800 11 37 11. Mattel España, S. A., Aribau 200 pl. 9, 08036 Barcelona. c.service.spain@mattel.com Tel: +34 933 06 79 00 <http://www.service.mattel.com/es>. Chinese mainland: Mattel Barbie (Shanghai), Trading Co., Ltd. Room 2005, 20th Floor, 899 Ruining Road, Xuhui District, Shanghai, 200232, P.R.C. Customer Care Line: 400-819-8658. Hong Kong SAR: Kids Kingdom Limited, Room 1908-9, Gala Place, 56 Dundas Street, Mongkok, Kowloon, Hong Kong, P.R.C. Customer Care Line: (852)2782-0766. Taiwan region: CHICKABIDDY CO., LTD, F5, No. 186, Sec. 4, Nanjing E. Rd., Taipei 10595, Taiwan region. Customer Care Line: 0800 001 256. Diimport & Diedarkan Oleh: Mattel Continental Asia Sdn Bhd, Level 19, Tower 3, Avenue 7, No. 8 Jalan Kerinci, Bangsar South, 59200 Kuala Lumpur, Malaysia. Mattel South Africa (PTY) LTD, Office 10213, 30 Melrose Boulevard, Johannesburg 2196. Dystrybutor: Mattel Poland Sp. z o.o., Budynek Skyliner 31 p., ul. Prosta 67, 00-838 Warszawa, Polska. Mattel Australia Pty. Ltd., 658 Church St., Richmond, Victoria, 3121. Consumer Advisory Service - 1300 135 312. Mattel AEBE, Εθνόργου Μακαρίου 1, Κτήριο Κ-2, ΤΚ 15711, Πλατεία Φόληρου, Mattel Oyuncakları Tic. Ltd. Şti. İçerenköy Mah., Umut Sokak No: 10 - 12, Quick Tower kat:2 (kapı no:15 Ataşehir 34752, İstanbul, Türkiye. Tel: 0216 570 75 00. Импортёр/Уполномоченная организация: ООО "МАТТЕЛ" Российская Федерация, 105120 Москва, 2-й Сыроматинский переулок, 1; +7 495 287 79 39. Mattel Czech Republic s.r.o., The Forum, Václavské nám. 19, 11000 Praha. Mattel, 333 Continental Boulevard, El Segundo, CA 90245, USA. Consumer Services: 1-800-465-MEGA (6342). Mattel Canada Inc., Mississauga, Ontario L5R 3W2. Consumer Services: You may call us free at/ Composez sans frais le 1-800-524-8697. Importado y distribuido por Mattel de México, S.A. de C.V., Miguel de Cervantes Saavedra No. 193, Pisos 10 y 11, Col. Granada, Alcaldía Miguel Hidalgo, C.P. 11520, México, Ciudad de México, R.F.C. MME-920701-NB3. Tels: 59-05-51-00 Ext. 5206 ó 01-800-463-59-89. Mattel Chile S.A., Pte. Riesco 5561, Of. 203-204 PS2, Las Condes, Santiago. Servicio al consumidor Venezuela: Tel: 0-800-100-9123. Mattel Argentina, S.A., Av. Libertador 1000, Piso 11 - Oficinas 109 y 11, Vicente López - Prov. Buenos Aires. Tel: 0800-666-3373. Mattel Colombia, S.A., Calle 12347-07 P5, Bogotá, Mattel Perú, S.A., Av. Juan de Arona n.º 151, Centro Empresarial Juan de Arona, Torre C, Piso 7, Oficina 704, San Isidro, Lima 27, Perú. RUC: 20425853865. Reg. Importador: 02350-12-JUE-DIGESA. Tel: 0800-54744. E-mail Latinoamérica: servicio.clientes@mattel.com. Mattel do Brasil Ltda. - CNPJ: 54.558.002/0001-20 - Rua Verbo Divino, 1488 - 2º Andar - 04719-904 - Chácara Santo Antônio - São Paulo - SP - Brasil. Serviço de Atendimento ao Consumidor: Contato: <https://faleconosco.mattel.com.br/Contato>. E-mail: sac.matteldobrazil@mattel.com

©2023 Pokémon. ©1995–2023 Nintendo / Creatures Inc. / GAME FREAK inc. TM, ®, and character names are trademarks of Nintendo.

©2023 Pokémon. ©1995–2023 Nintendo/Creatures Inc./ GAME FREAK inc. TM, ® et les noms des personnages sont des marques de Nintendo.

EEVEE / ÉVOLI / EVOLI





Discover & display the whole line
 Découvrez et exposez toute la gamme

Descubre toda la colección y crea una exposición
 Descubre e expõe toda a linha
 Alle Produkte der Reihe entdecken und präsentieren
 Собери и выстави всю серию

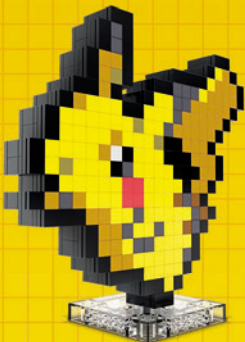

HTH74



HTH75



HTH76

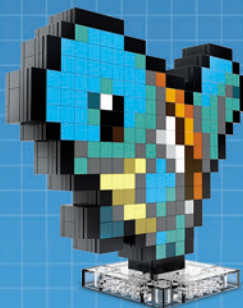

HTH77



HTH78

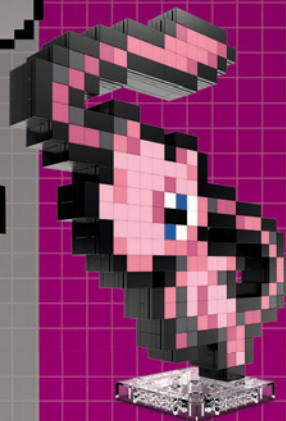

HWR80

MEGASHOWCASE.com

Set(s) sold separately and subject to availability. / Ensemble(s) vendu(s) séparément. Certains produits peuvent ne pas être commercialisés. / Se vende(n) por separado y está(n) sujeto(s) a disponibilidad. / Conjunto(s) vendido(s) em separado e sujeito(s) à disponibilidade. / Set in vendita separatamente, secondo disponibilità. / Das/Die Set(s) sind separat erhältlich. / Zestaw(y) sprzedawany(e) oddzielnie w zależności od dostępności. / Set(s) apart verkrijgbaar en afhankelijk van beschikbaarheid. / Набор(-ы) продаются отдельно, при наличии. / Sæt sælges separat og så længe lager haves. / Seten säljs separat så länge lagret räcker. / Settet/settene selges separat så langt lageret rekker. / Pakkaus/pakkausset myydään erikseen, saatavuus voi vaihdella. / Το(α) σετ πωλούνται ξεχωριστά και αυθόρμητα με τη διαθεσιμότητα. / Setler ayrı olarak satılır ve stoklarla sınırlıdır. / Set (sety) se prodává (prodávají) samostatně dle aktuální nabídky. / Súprava-/y sa predáva(jú) samostatne a podľa dostupnosti. / A készlet(ek) külön kapható(k), az elérhetőség változhat. / セット商品は別売りになります。在庫状況は別途ご確認をお願いします。 / إنتاج المجموعة أو المجموعات على حدة وتخضع لتوافرها.

Mattel Canada Inc. Mississauga, Ontario L5R 3W2.
 MADE IN CHINA. FABRIQUÉ EN CHINE. FABRICADO NA CHINA. HECHO EN CHINA.
 ИЗГОТОВЛЕНО В КИТАЕ. ÇIN'DE ÜRETİLMİŞTİR. صنع في الصين.

©2023 MEGA Brands &™ MEGA Brands.
 Printed in China / Imprimé en Chine
 AD-HTH78-01

™ & ©2023 Mattel.

1186 MJ, 1, NL



Adresses sur quefairedemesdechets.fr

