



XBOX 360[®]

HWW15



COLLECTOR BUILDING SET
BOÎTE DE CONSTRUCTION
POUR COLLECTIONNEUR

3:4 SCALE MODEL
ÉCHELLE

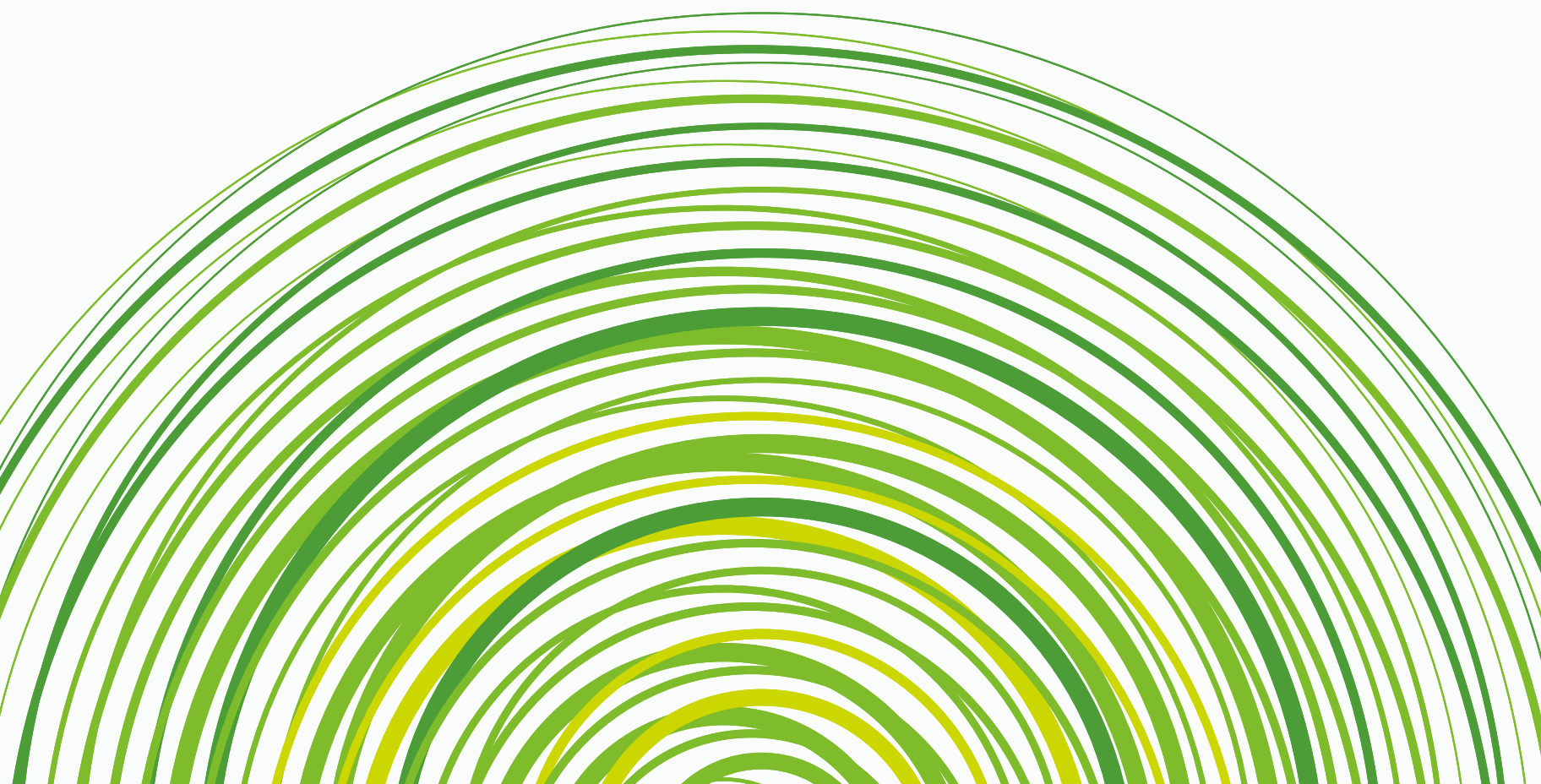

Controller / Télécommande

Mando / Comando / Controller / Геймпад



Kontroler / Χειριστήριο / Düğmeler / Vezérlő / Handkontroll
Ohjain / Kontroller / Ovladač / Ovládač / جهاز التحكم

Xbox 360 Console / Console de jeux Xbox 360

Consola Xbox 360 / Consola Xbox 360

Xbox 360-Konsole / Консоль Xbox 360



Console Xbox 360 / Konsola Xbox 360
Κονσόλα Xbox 360 / Xbox 360 Konsolu / Xbox 360 konzol
Xbox 360-konzol / Xbox 360 -konsoli / Xbox 360-konzol
Xbox 360-konsoll / Konzole Xbox 360 / Konzola Xbox 360 / Xbox 360 جهاز

Halo 3 Disc and Case / Disque et boîtier Halo 3

Disco y caja del juego Halo 3 / Disco e caixa do Halo 3

Halo 3-Diskette und -Hülle / Диск и коробка Halo 3



Disco e custodia Halo 3 / Opakowanie i płyta Halo 3 / Halo 3 schijf en hoes / Δίσκος και Θήκη Halo 3 / Halo 3
Diski ve Oyun Kutusu / Halo 3 lemez és tok / Halo 3-skiva och fodral / Halo 3 -levy ja kotelo / Halo 3-disk og
etui / Halo 3-skive og -veske / Disk a pouzdro Halo 3 / Disk Halo 3 a puzdro / Halo 3 Disk and Case قرص و علبة

*Disclaimer: This is a building set, not a functional video game console and disc.

Avertissement : Ceci est un coffret de construction, pas une console de jeux vidéo fonctionnelle avec disque. / *Aviso legal: Esto es un conjunto de construcción, no una consola de videojuegos ni un disco funcionales. / *Exclusão de responsabilidade: Este produto é um conjunto de construção, não um disco nem uma consola de videojogos funcionais. / * Disclaimer: Dies ist ein Bauset, keine funktionierende Videokonsole und Disc. / *Правовая оговорка. Это набор для сборки, а не функционирующая консоль для видеоигр и диск. / *Dichiarazione di non responsabilità: questo è un set di costruzioni, non contiene una console e un disco per videogiochi funzionanti. / * Zastrzeżenie: ten produkt jest zestawem klocków, a nie działającą konsolą do gier ani płytą. / *Disclaimer: Dit is een bouwset, geen functionele console of cd voor videogames. / *Σημείωση: Αυτό είναι σετ κατασκευών, όχι λειτουργική κονσόλα και δίσκος βιντεοπαιχνιδιών. / *Yasal Uyarı: Bu bir yapı setidir, çalışan bir video oyun konsolu ve disk değildir. / *Ansvarsfraskrivelse: Dette er et byggesæt, ikke en ægte spillkonsol eller disk. / *Friskrivning: Det här är ett byggset, inte en funktionell spelkonsol och skiva. / *Ansvarsfraskrivelse: Dette er et byggesæt, ikke en funksjonell spillkonsoll og disc. / *Vastuuvapauslauseke: Tämä on rakennussarja, ei toimiva videopelikonsoli ja levy. / *Felelősségvállalással kapcsolatos megjegyzés: Ez egy építőkészlet, nem egy működő videojáték-konzol és lemez. / *Zbavení odpovědnosti: Jedná se o stavebnici, nikoli o funkční herní konzoli s diskem. / *تنويه: هذه مجموعة بناء وليست وحدة تحكم وألعاب فيديو عملية.



BUILDING TOOL OUTIL DE CONSTRUCTION

HERRAMIENTA
DE CONSTRUCCIÓN
BAUWERKZEUG
FERRAMENTA DE
MONTAGEM
ИНСТРУМЕНТ ДЛЯ
КОНСТРУИРОВАНИЯ

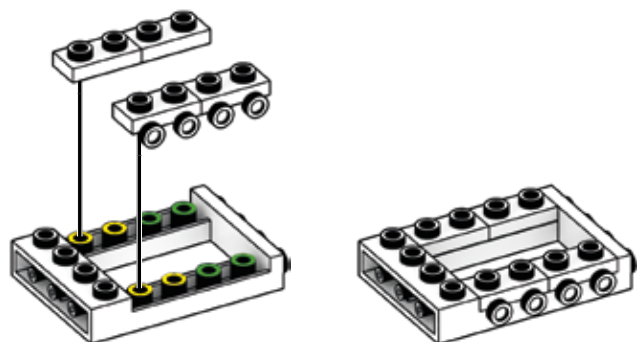
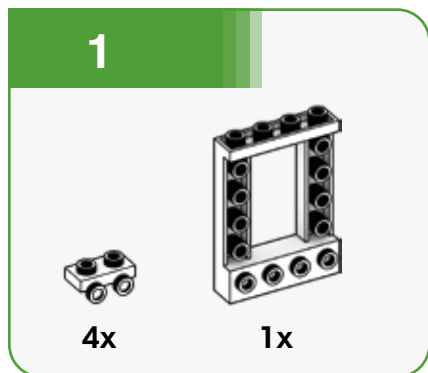
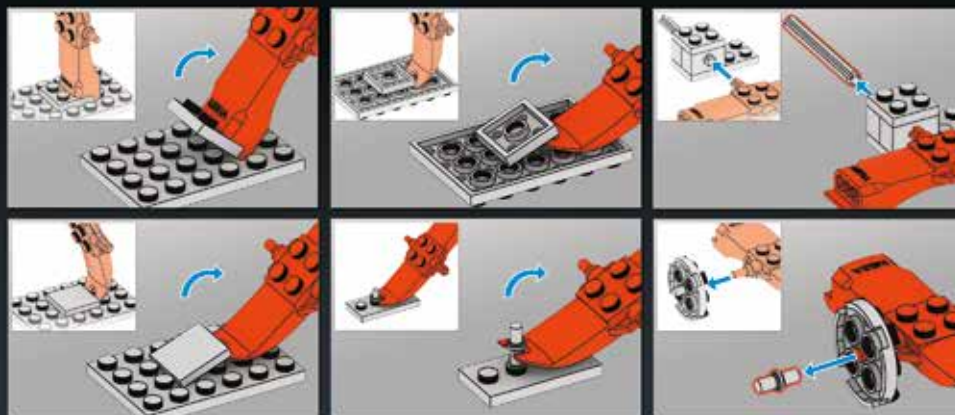

1

2

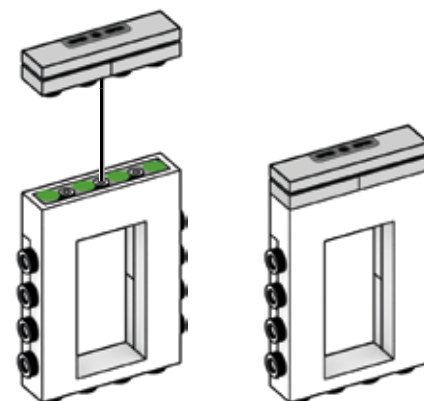
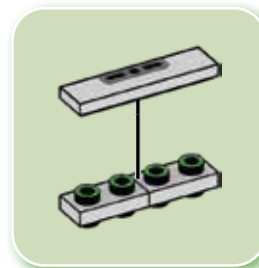
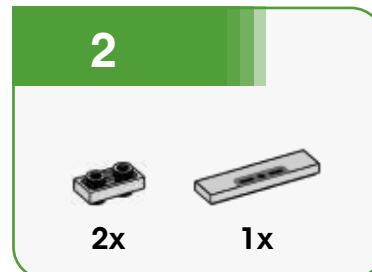

1

2

3

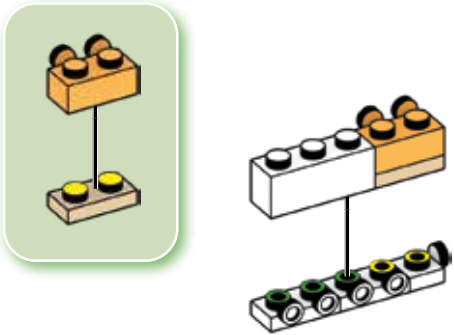
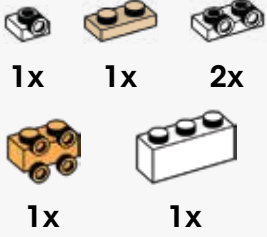

4

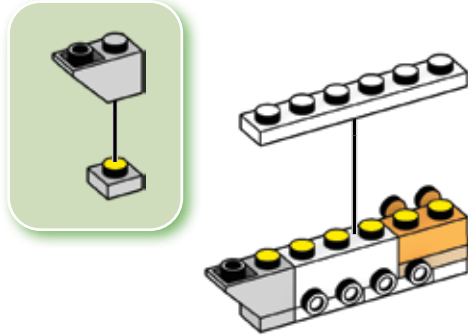
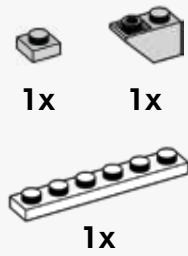

5

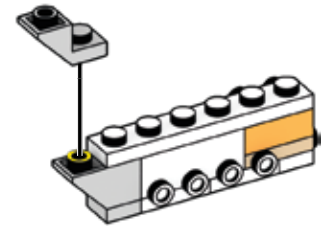

6

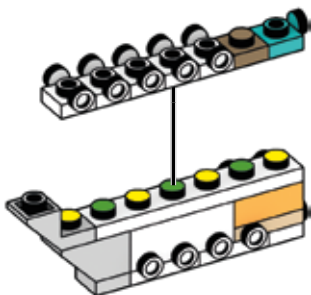

7

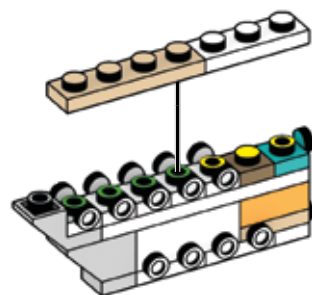

8

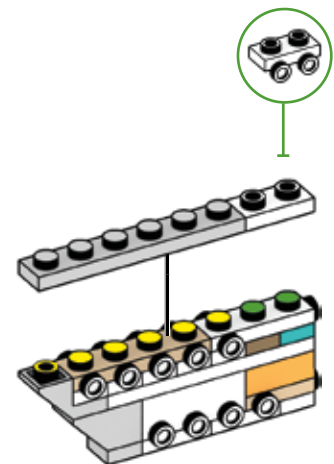
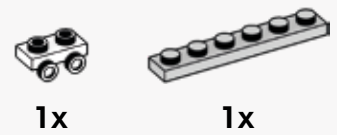

9



1x

1x

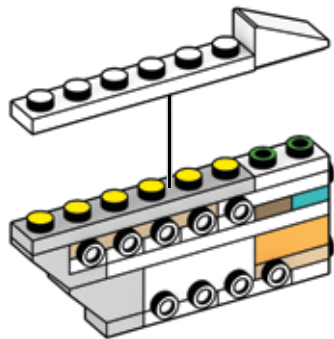

10



1x

1x

1x

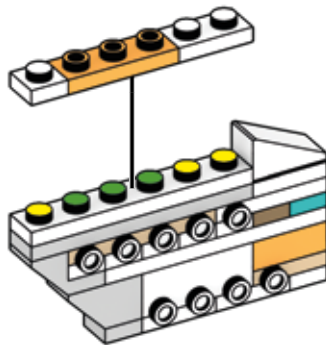
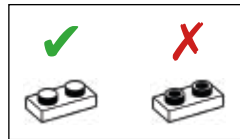

11



1x

1x

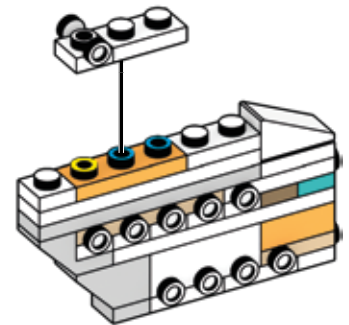
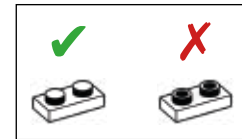

12



1x

1x

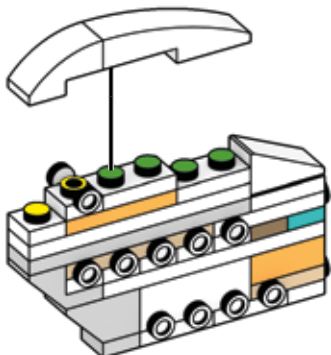

1

13



1x

1x

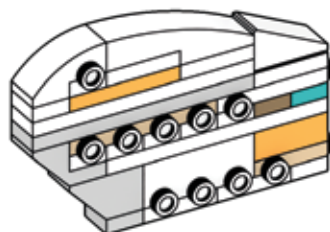

2

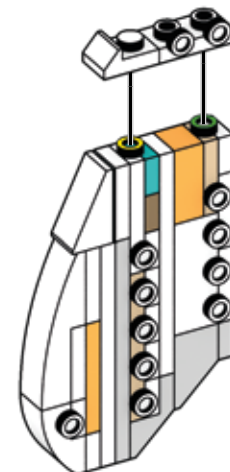

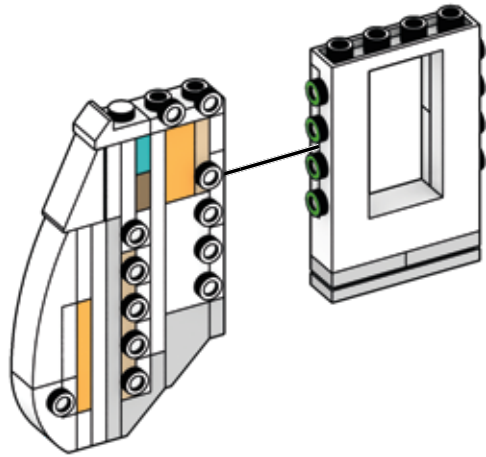

1

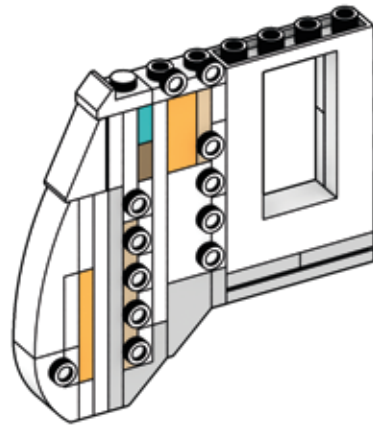

2

15

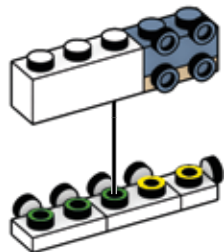
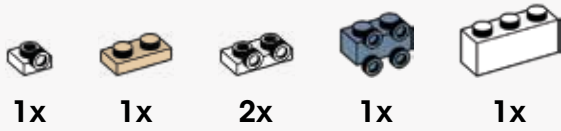

16

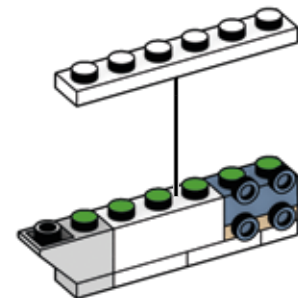
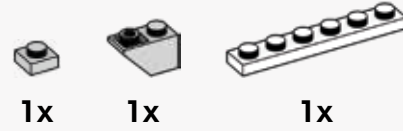

17



1x

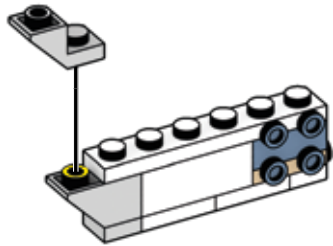

18



1x



1x



5x

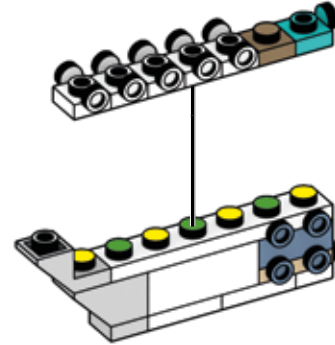

19



1x



1x

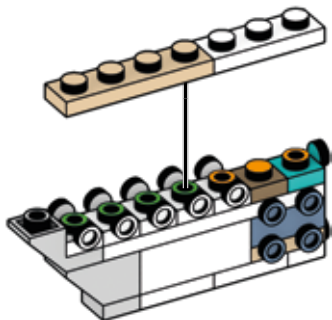

20



1x



1x

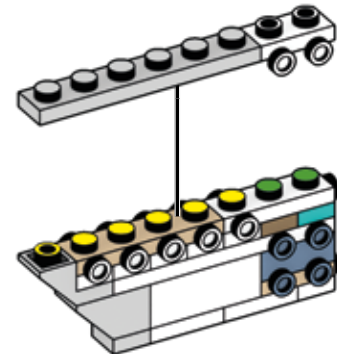

21

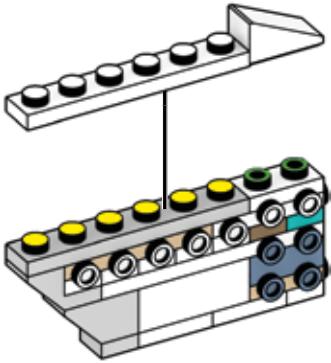
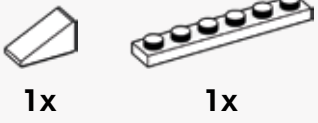

22

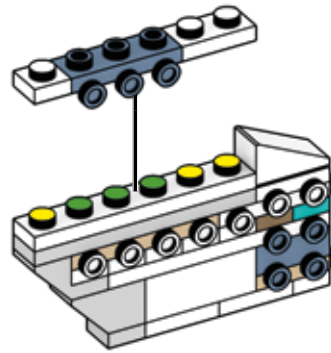
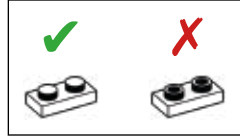

23

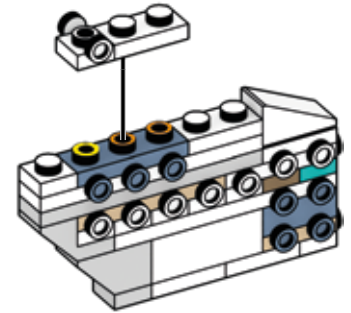
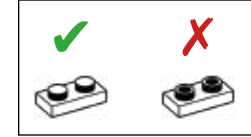

24

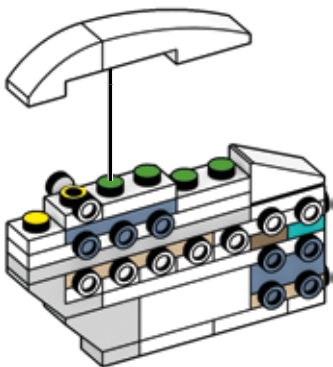
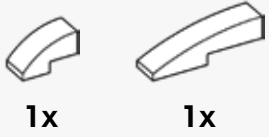

1

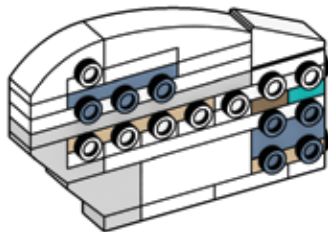

2

25

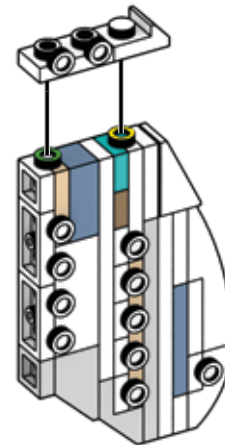

1

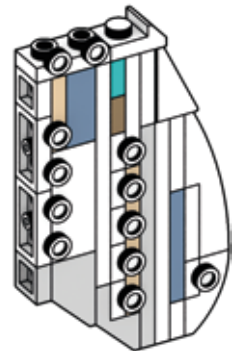

2

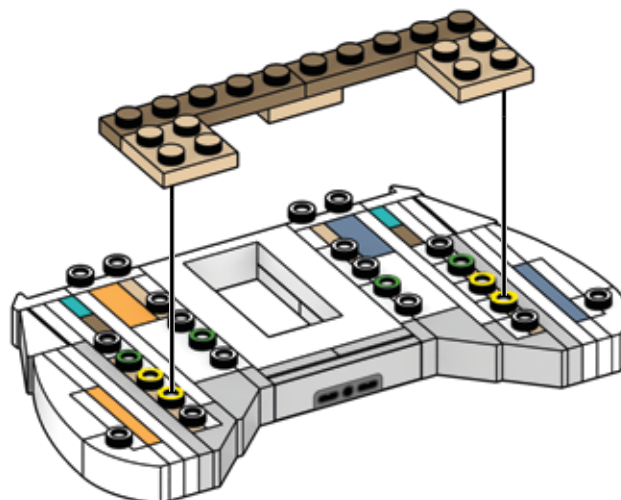
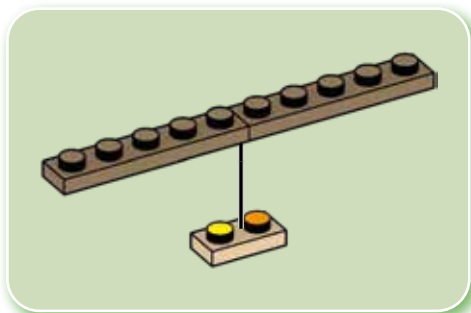
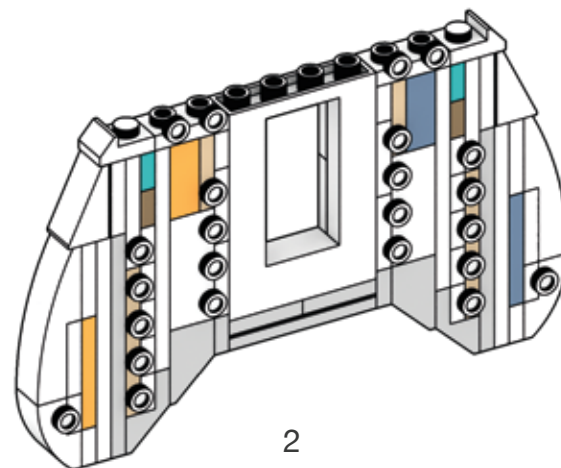
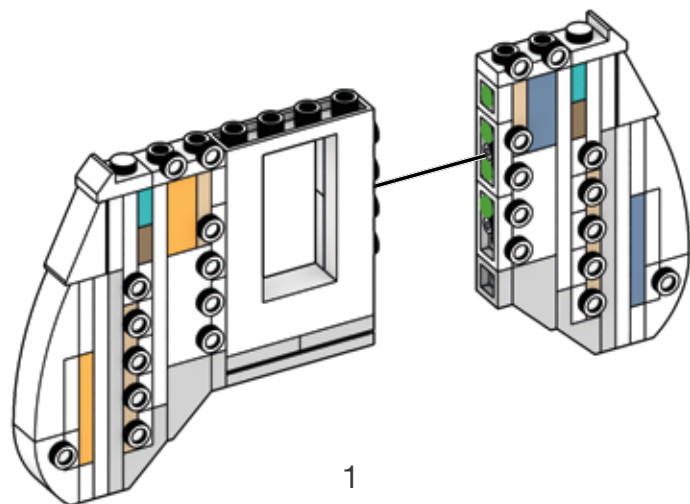

28



2x



2x

x2

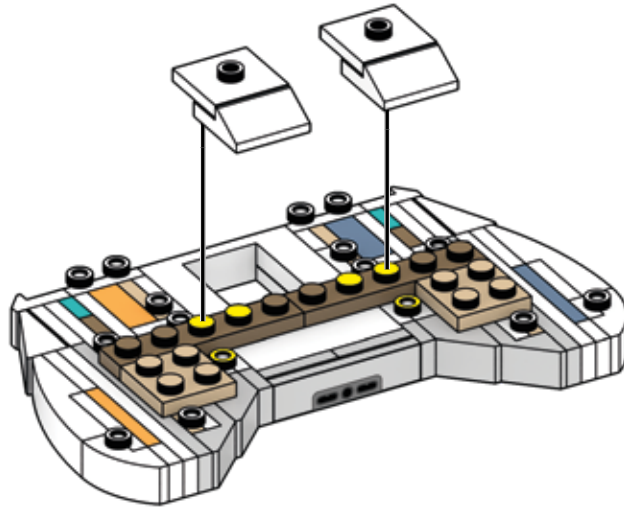
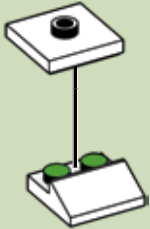

29



1x



1x

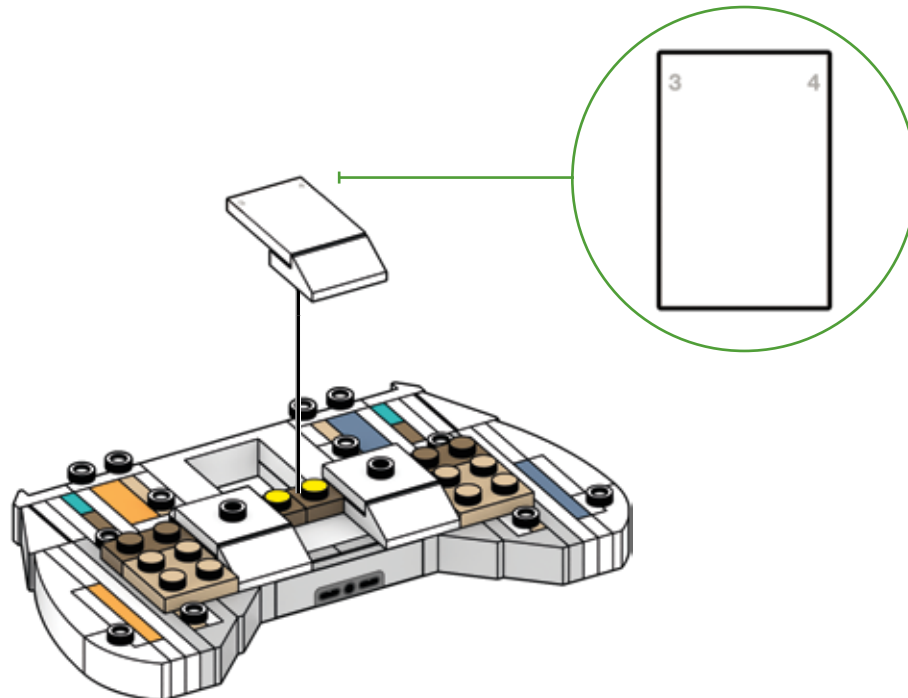
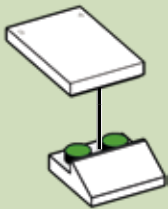

30



1x

1x

1x

1x

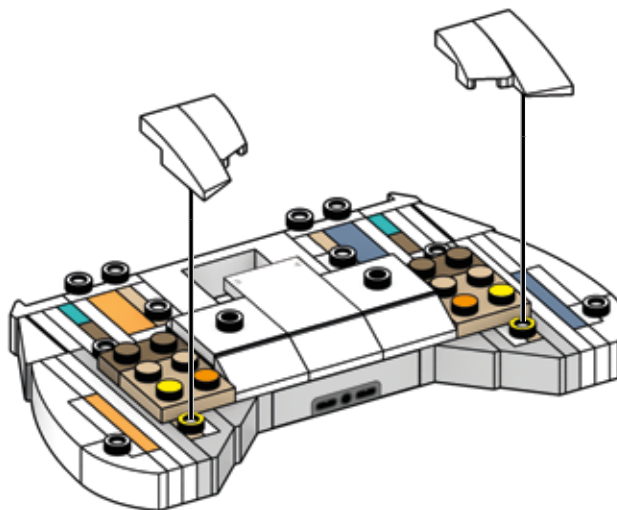

31



2x

2x

x2

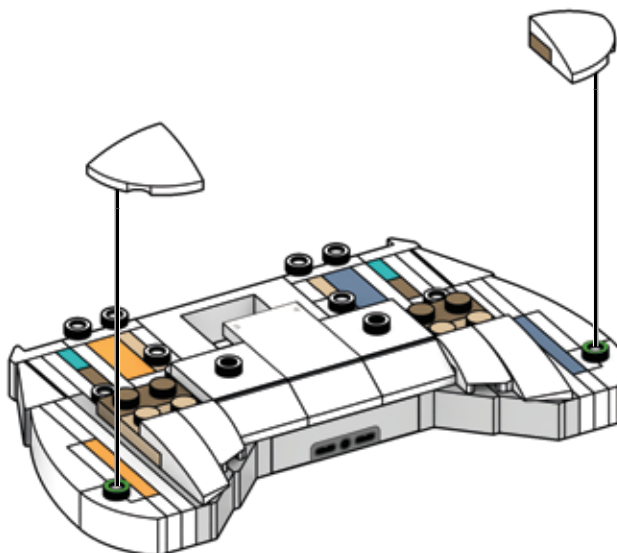

32

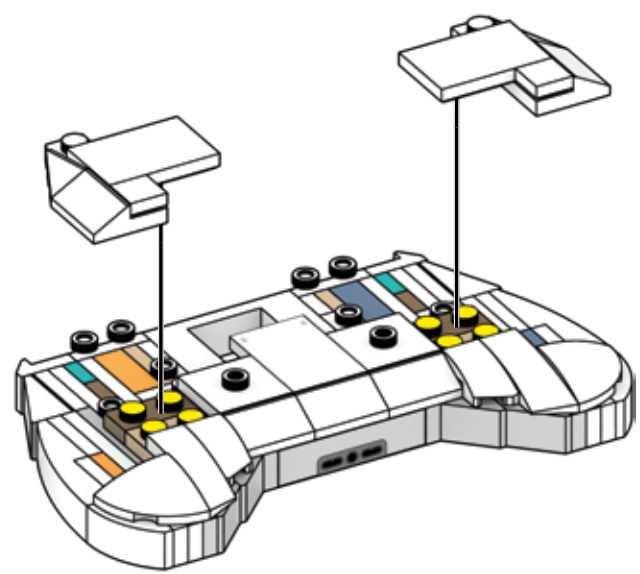
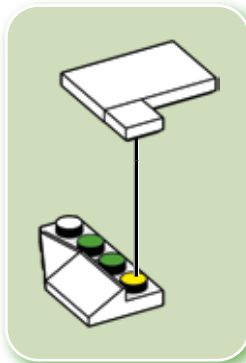
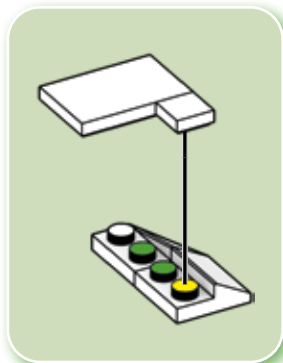

1

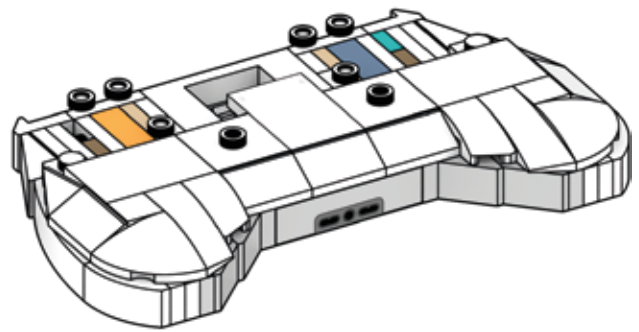

2

33

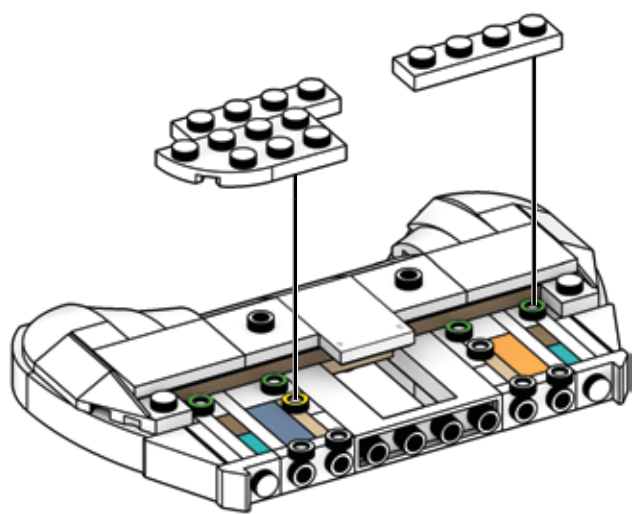

34

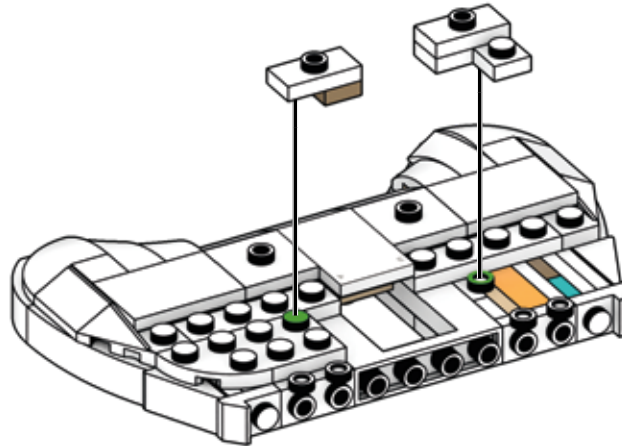
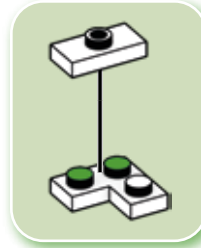
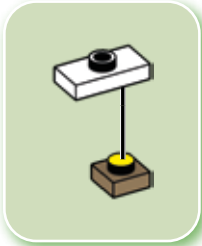
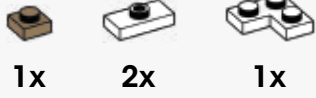

35

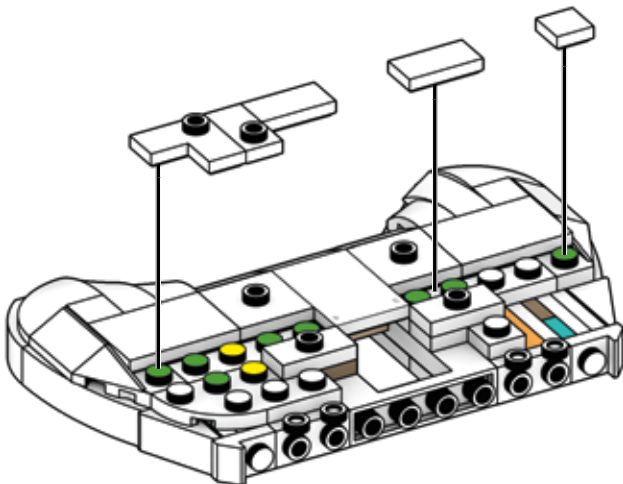
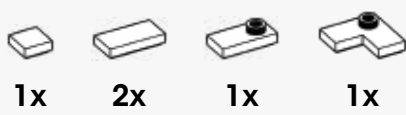

36

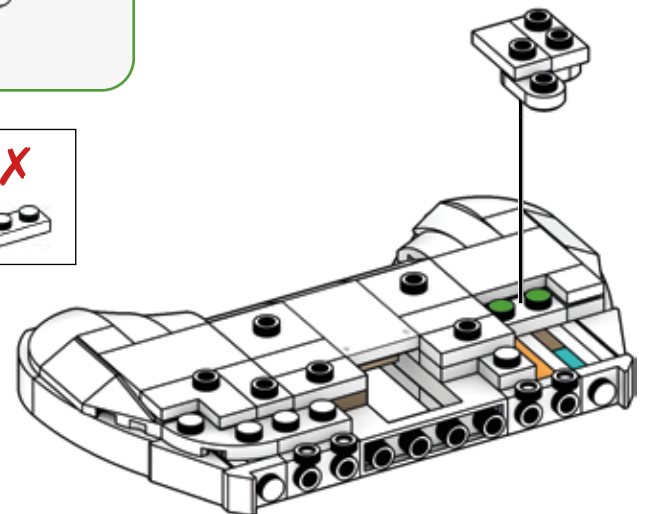
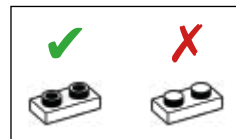
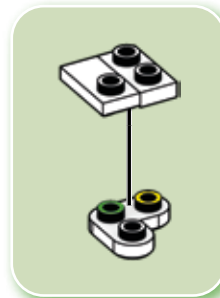
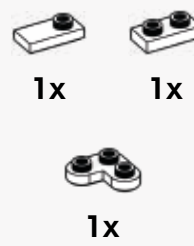



37



1x



2x



1x

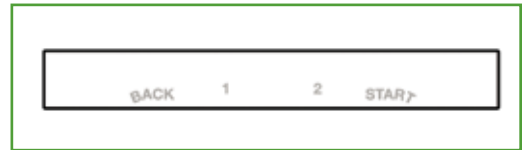
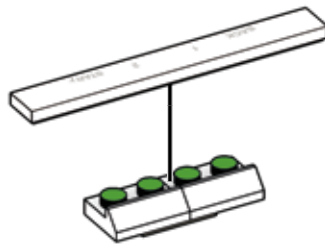
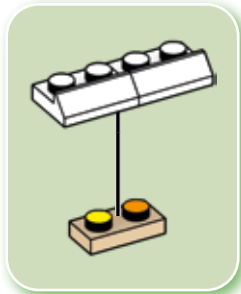

38



1x

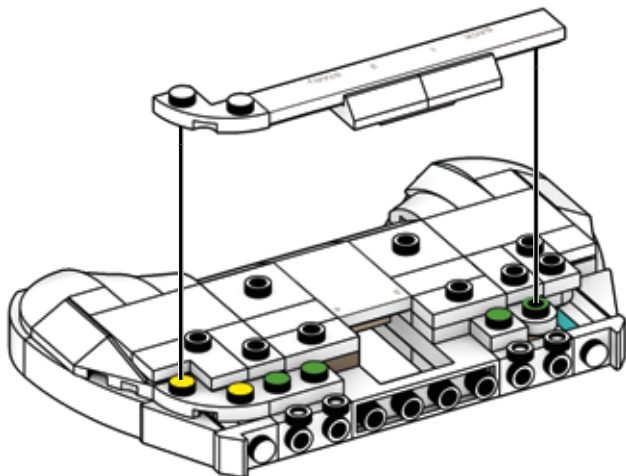

1

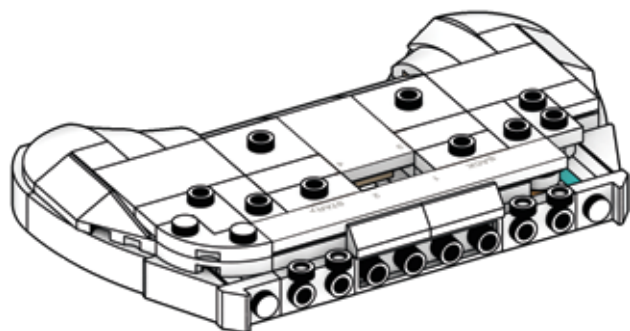

2

39



2x

4x

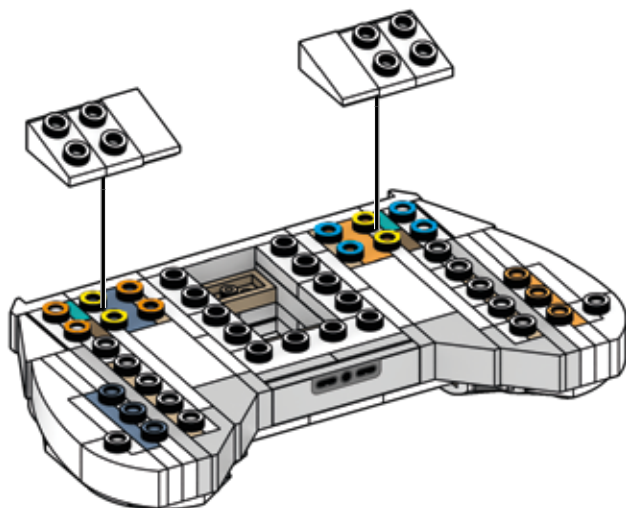

40



2x

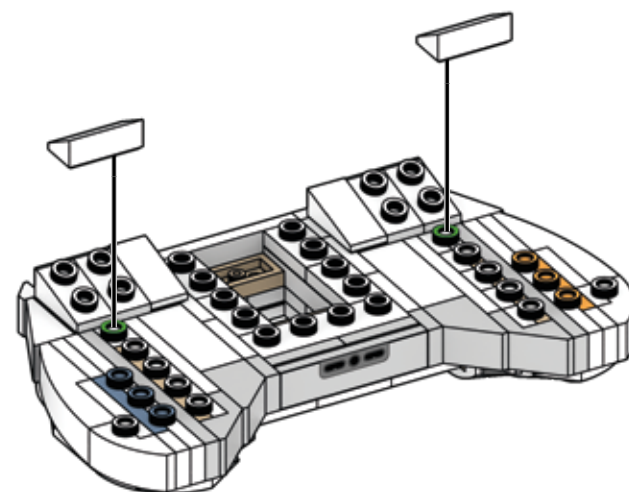

41



2x



2x



2x

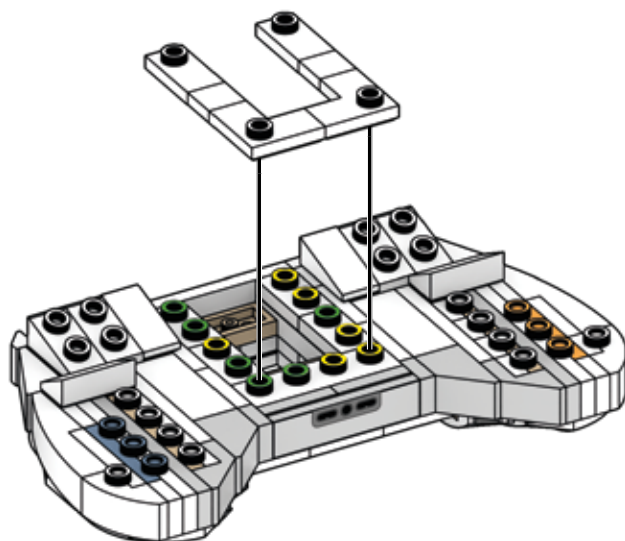

1

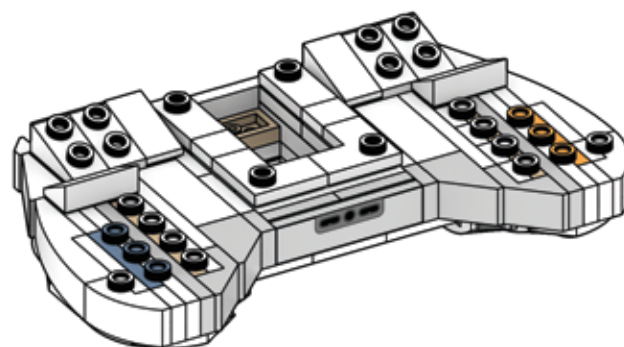

2

42



1x



1x



2x



1x



1x



1x

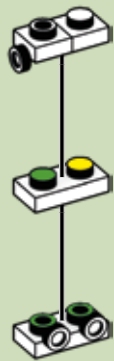

1

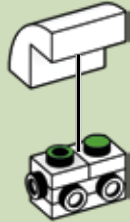

2

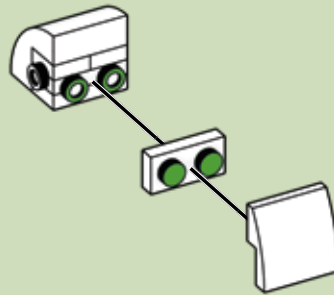

3

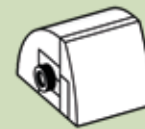

4

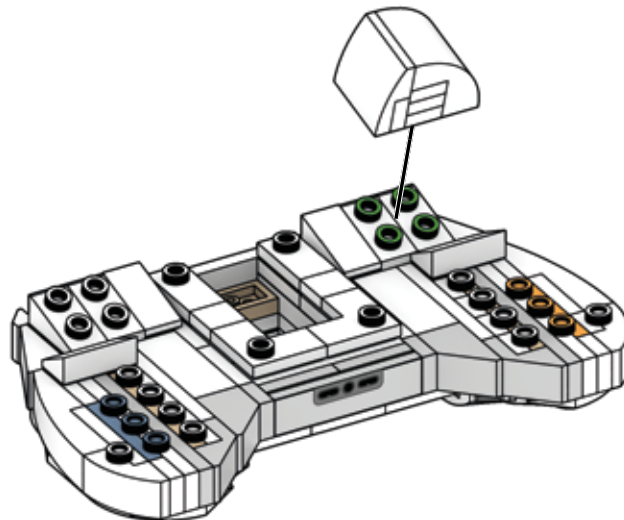

43



1x



1x



2x



1x



1x



1x

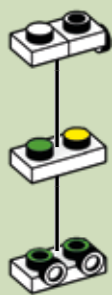

1

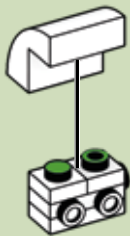

2

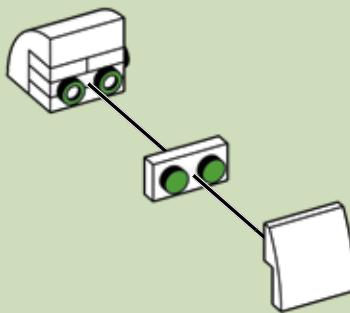

3



4

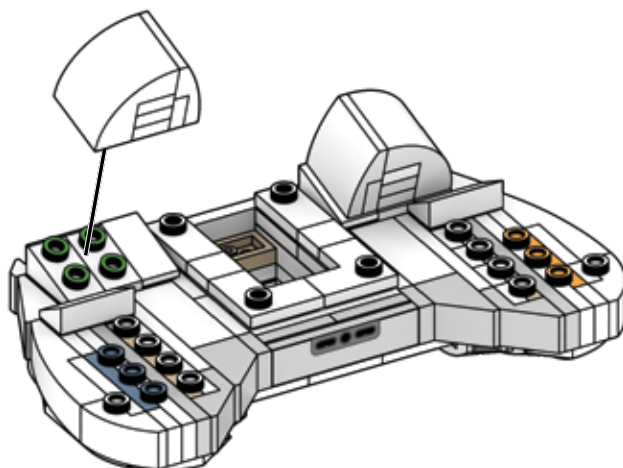

44



2x

2x

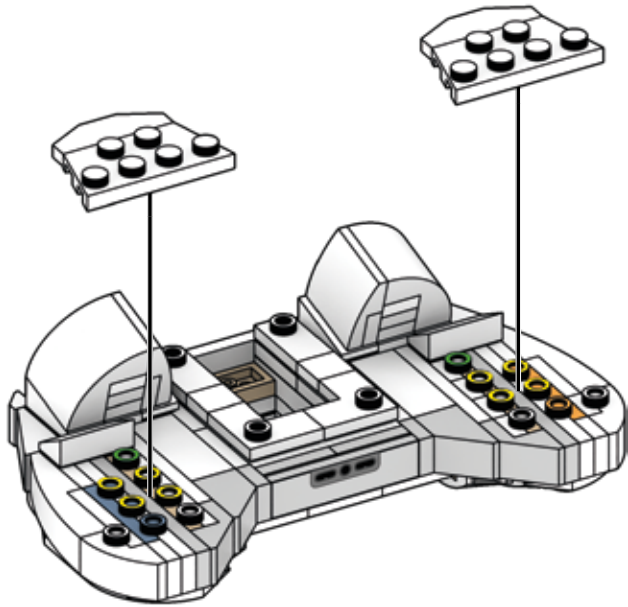

45



2x

2x

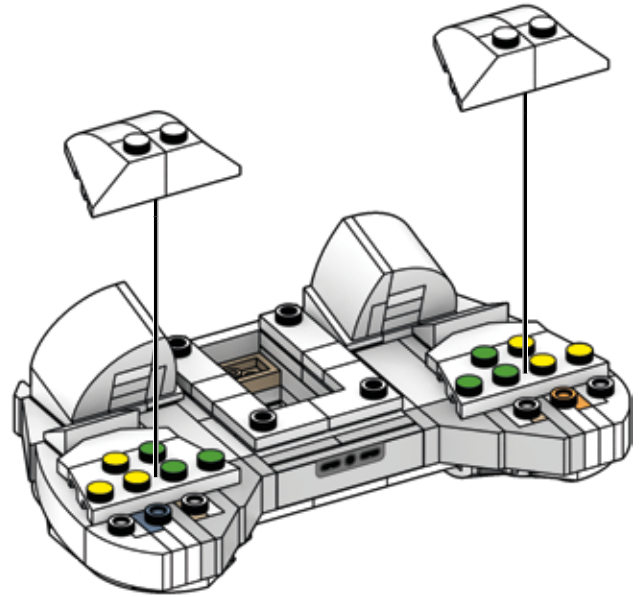

46



2x

4x

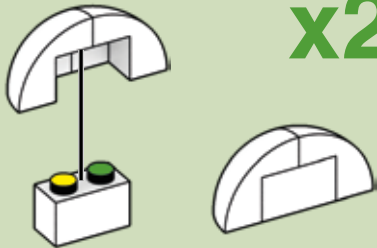

x2

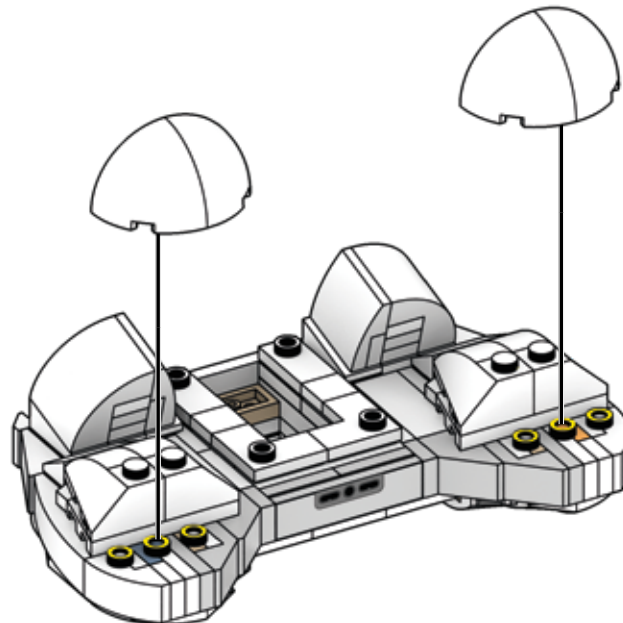

47



1x

1x

1x

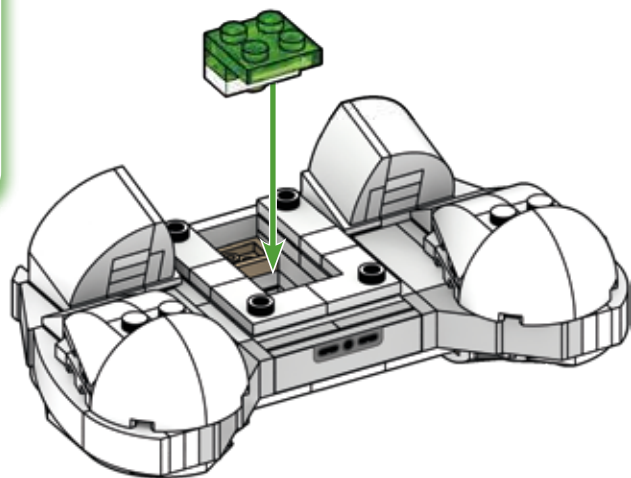
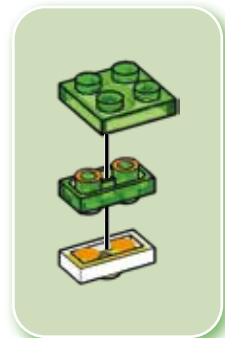

1

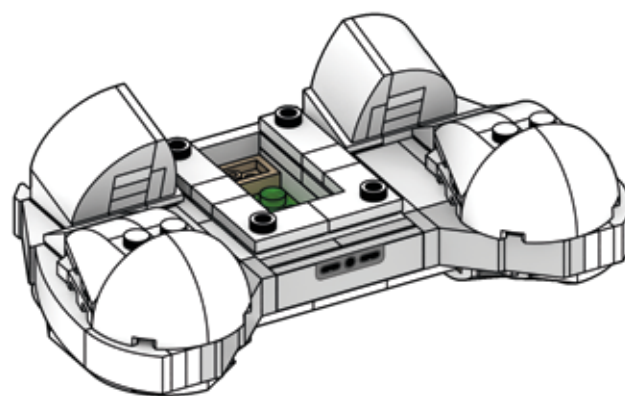
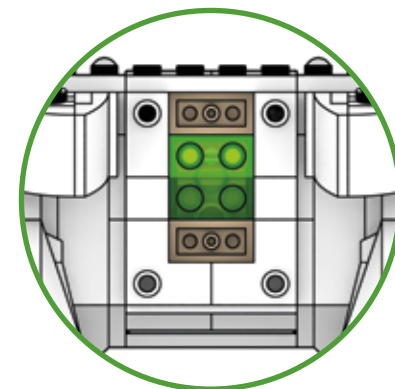

2

48



1x

4x

1x

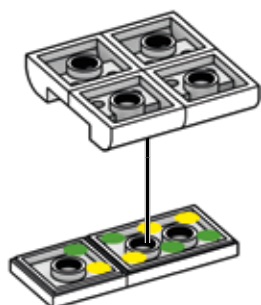

49



1x

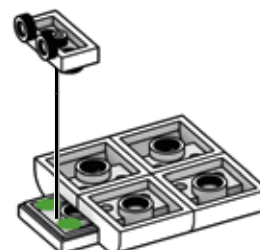

50



2x

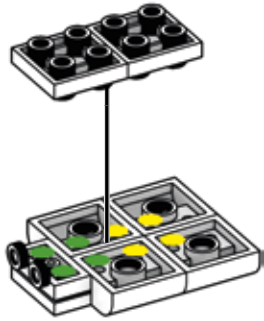

51

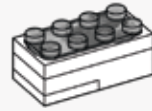

1x

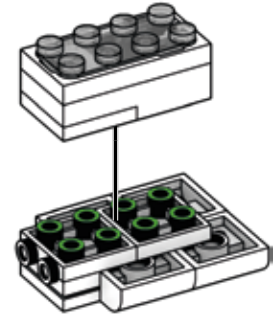
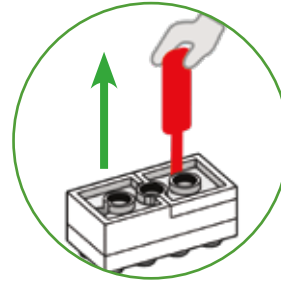

52



2x



3x

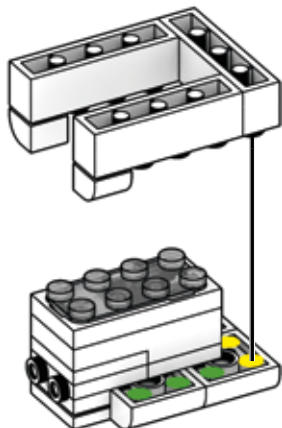
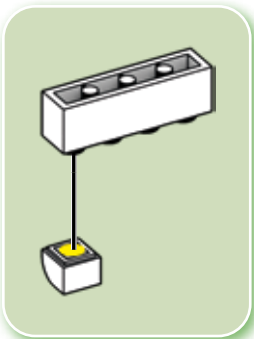
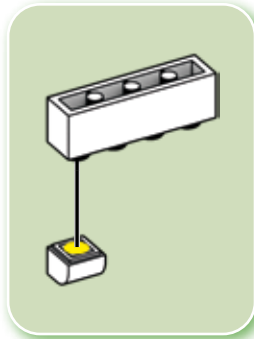

53



1x

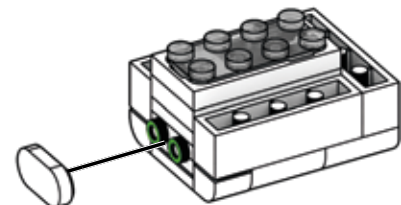

1

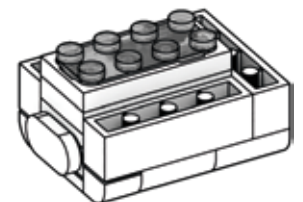

2

54

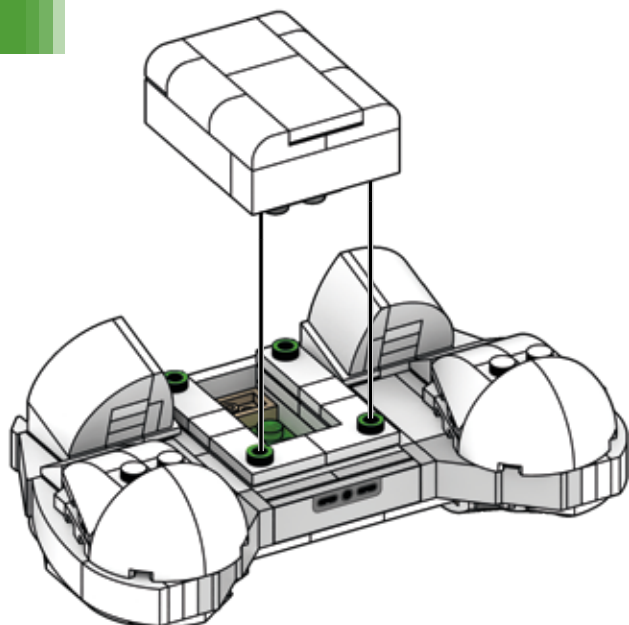

1

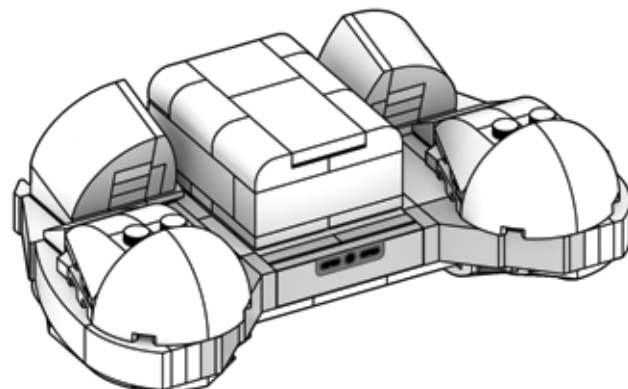

2

55

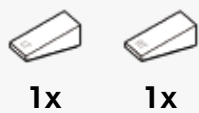

1x

1x

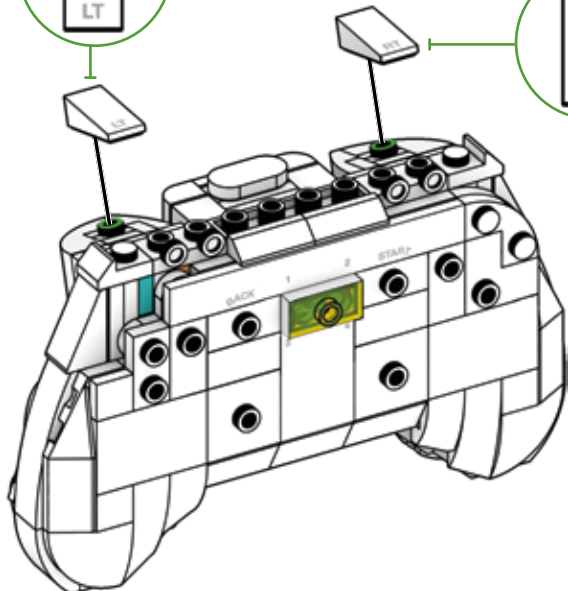
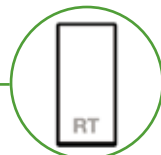
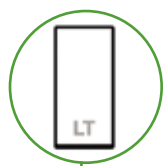

56



1x

1x

1x

2x

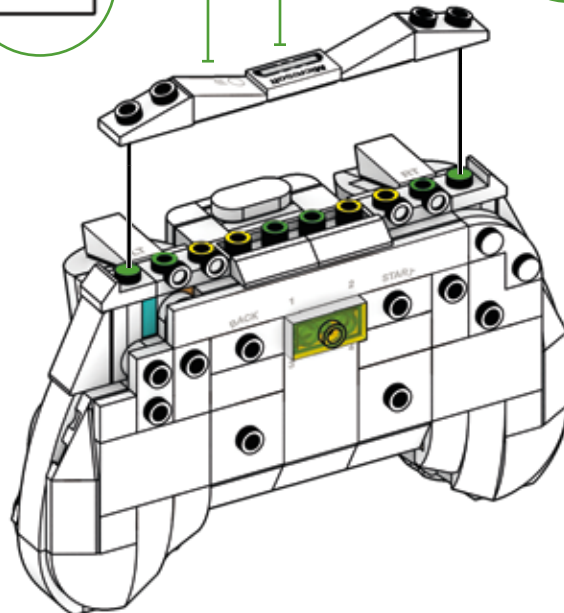
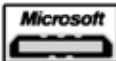
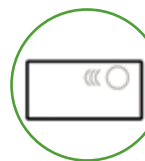

57

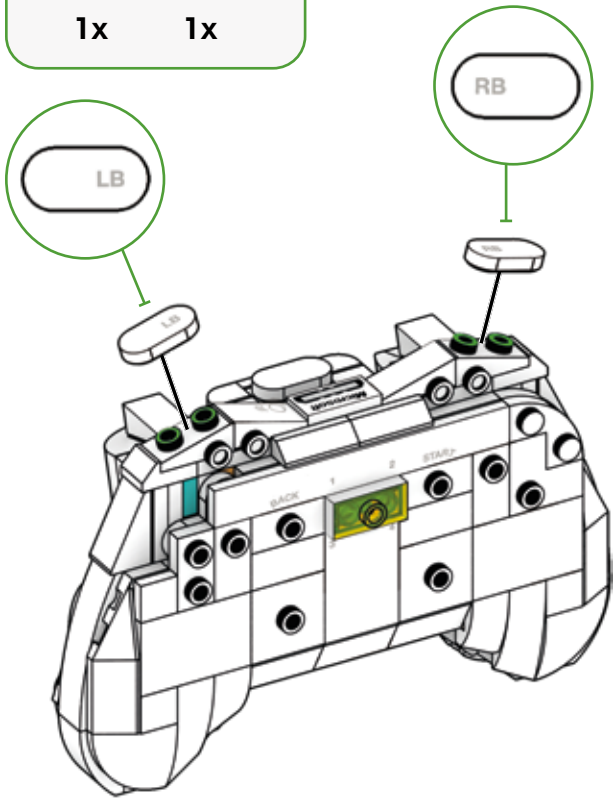
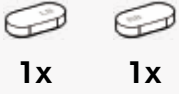

58

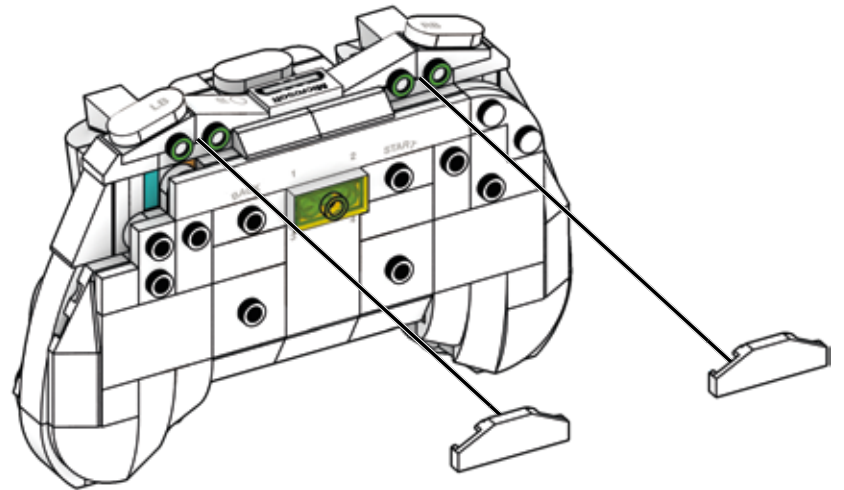

59

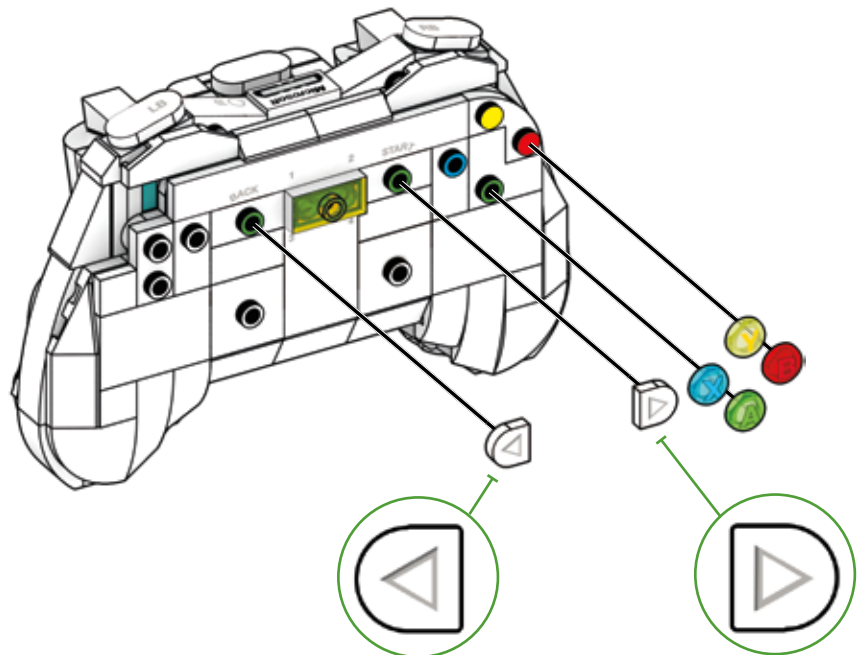
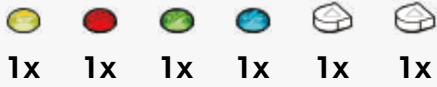

60

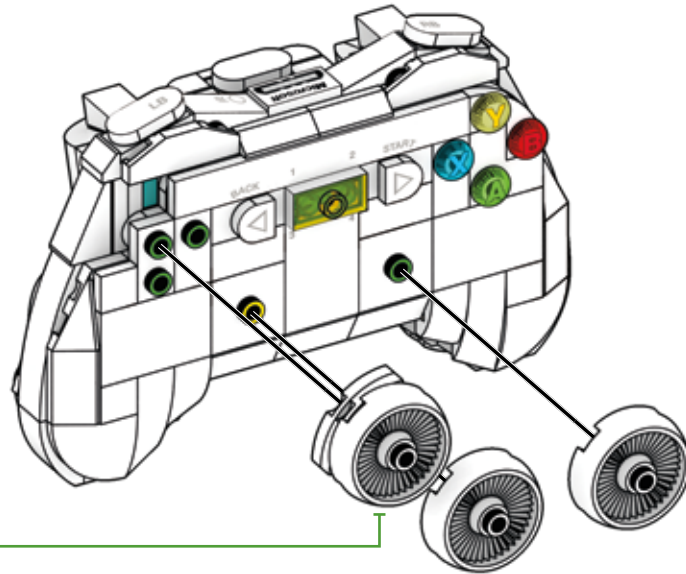
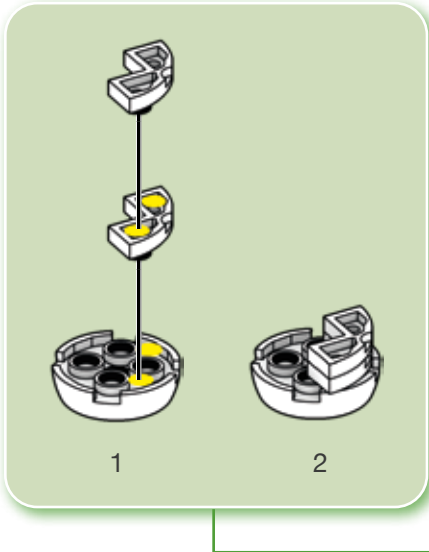
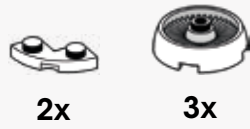

61

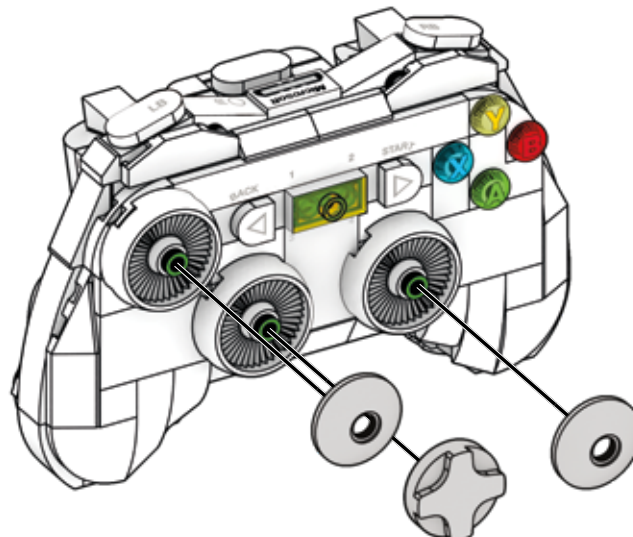
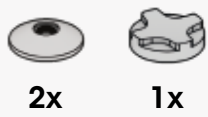

62



1x



2x

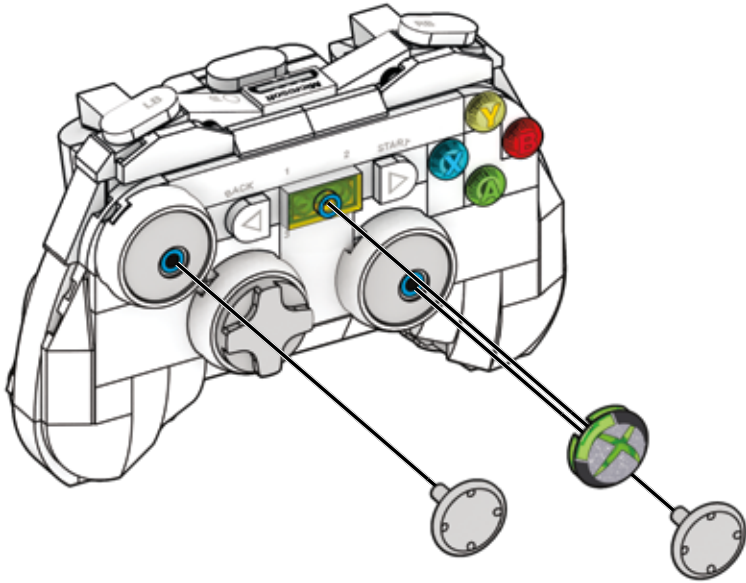

1

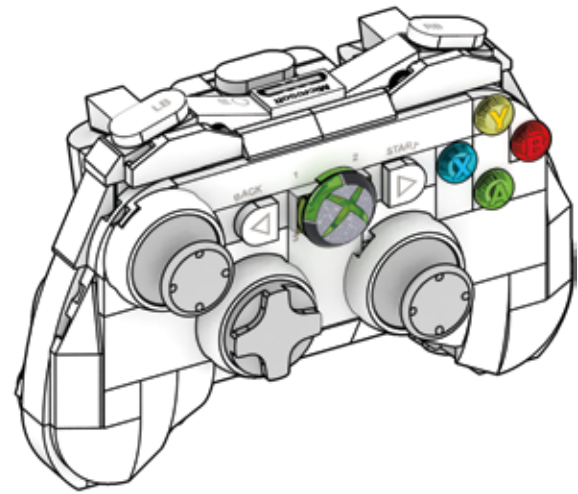

2

63



2x



1x

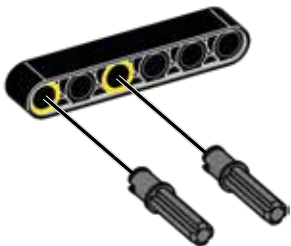

64



1x



1x

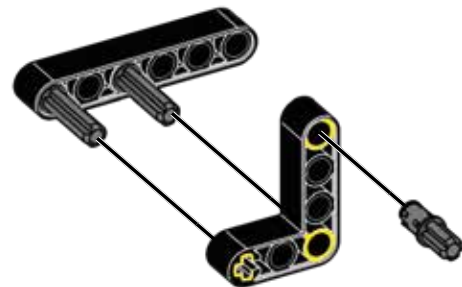

65



3x

66



2x



1x

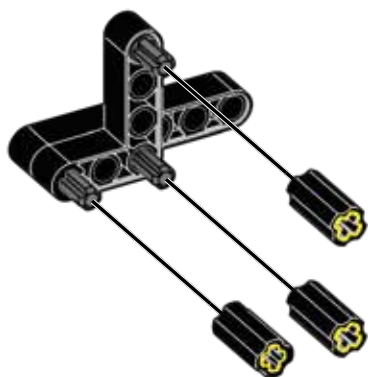

1



2

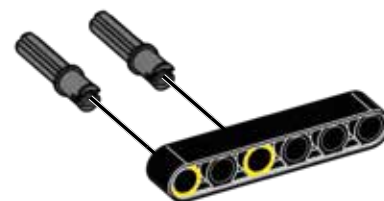

67



1x



1x

68

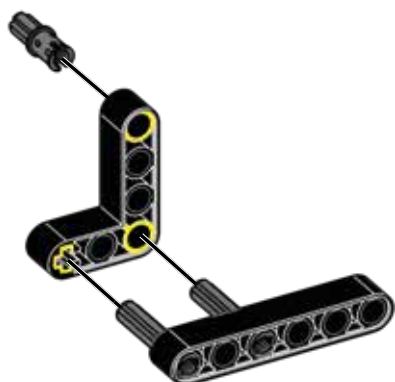

1

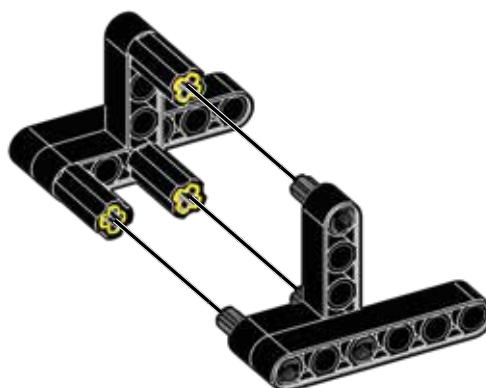

2

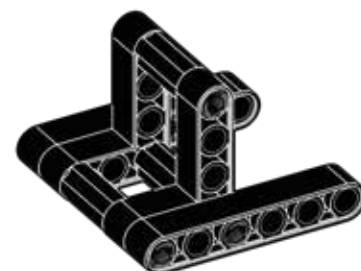

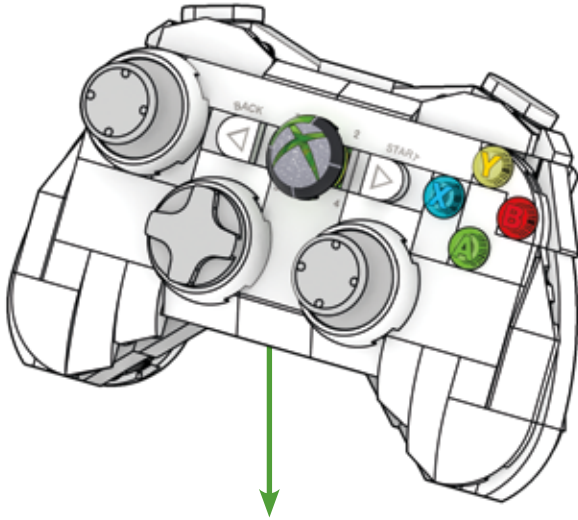

1

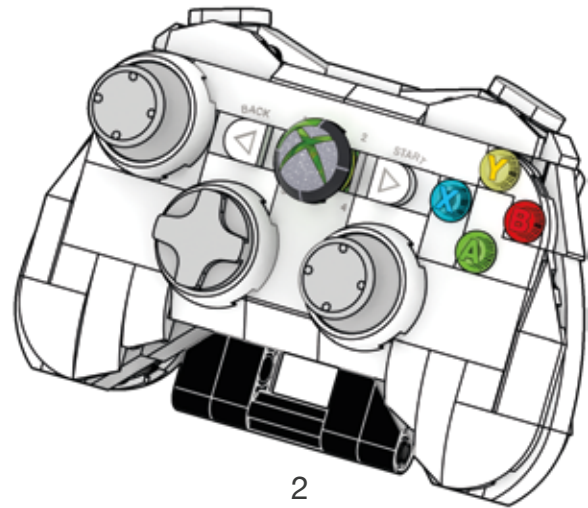

2



70



1x



1x



1x

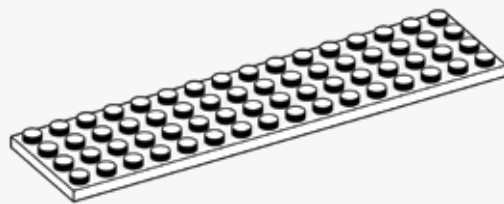

1x

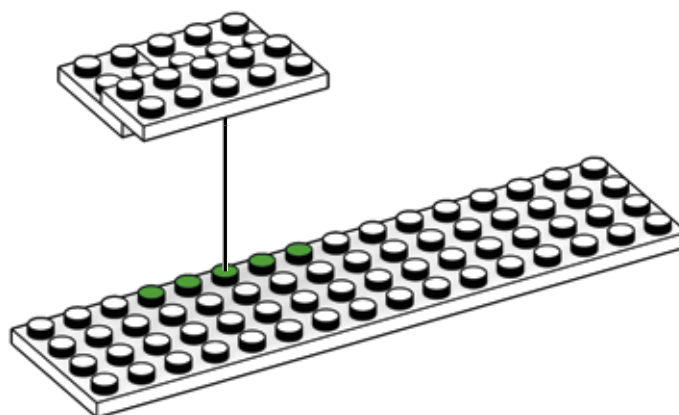
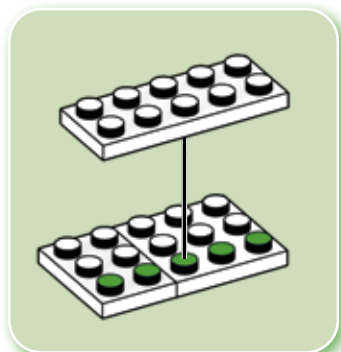

71



1x



1x



1x

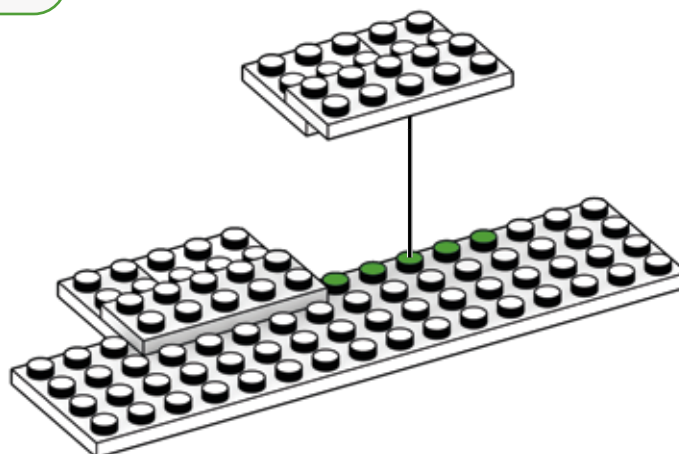
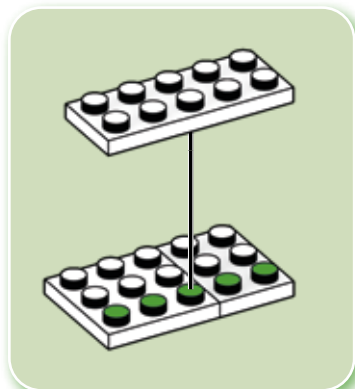

72

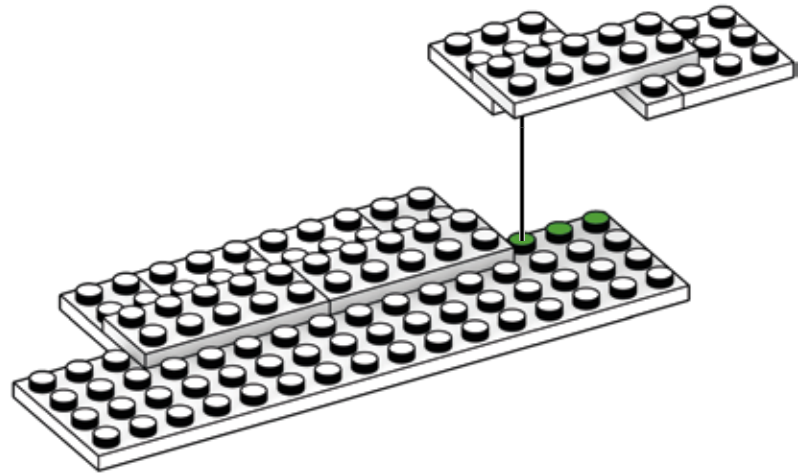
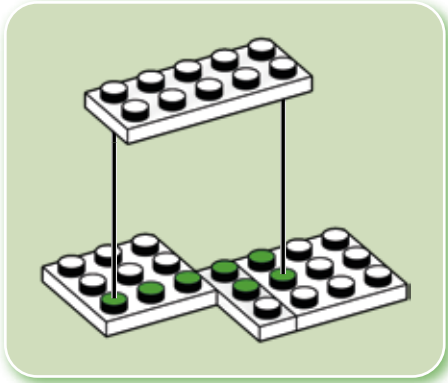
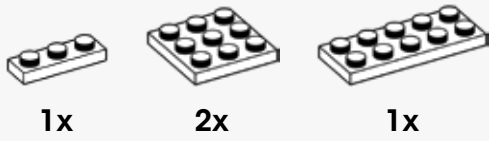

73

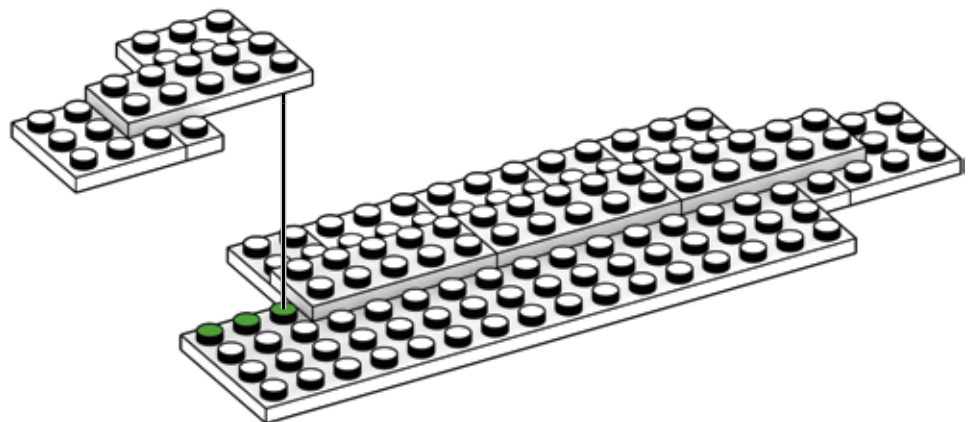
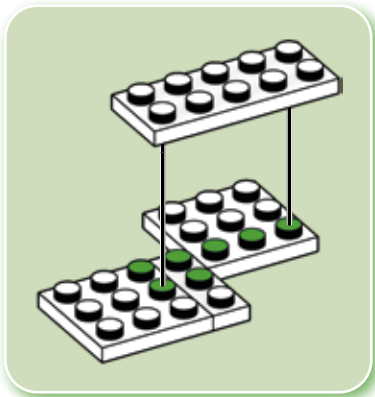
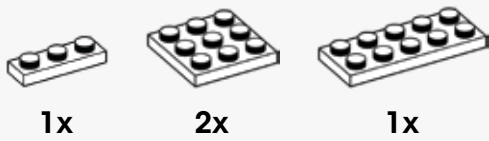

74



1x

1x

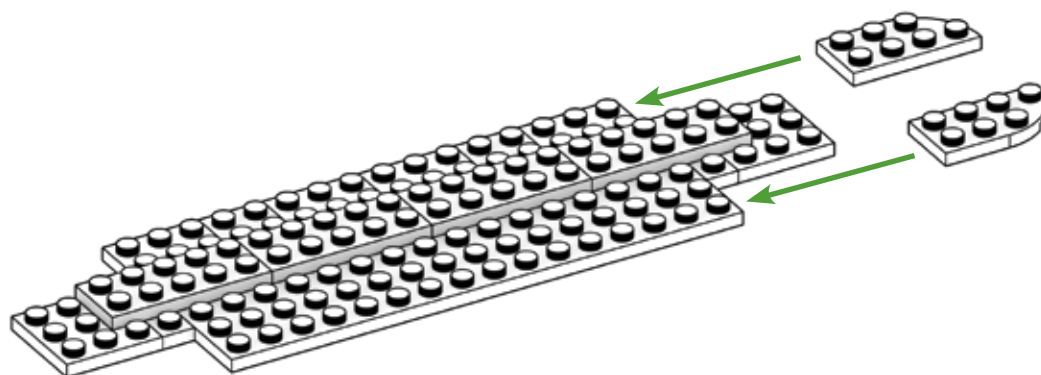

75



1x

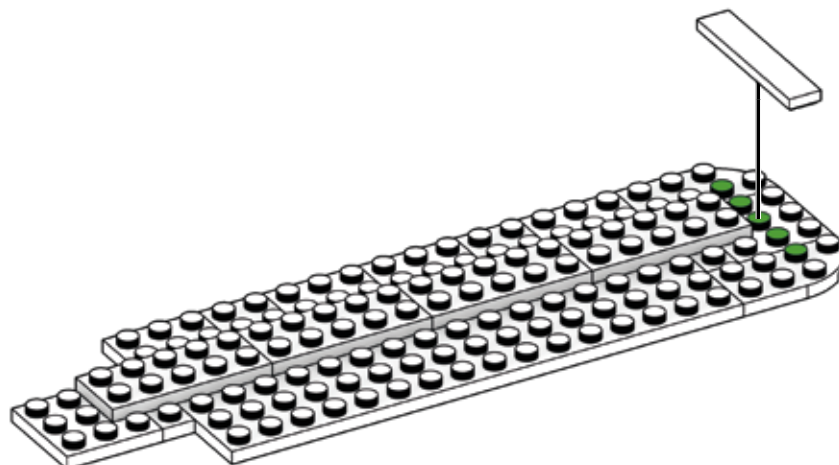

76



1x

1x

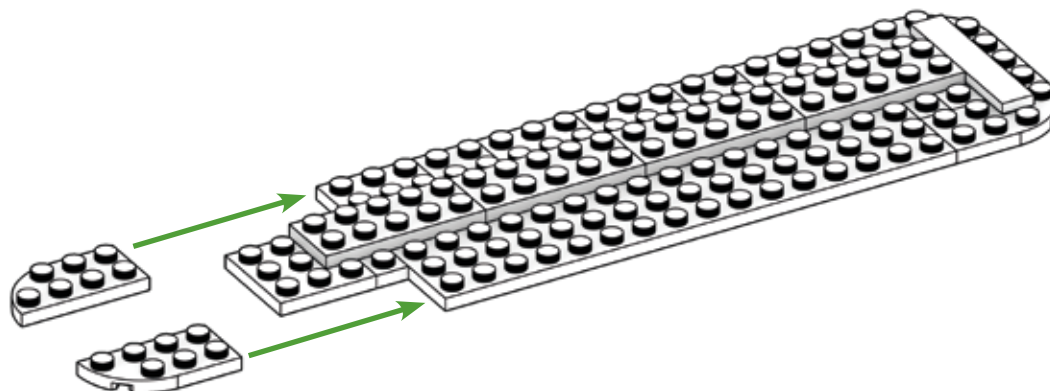

77



1x

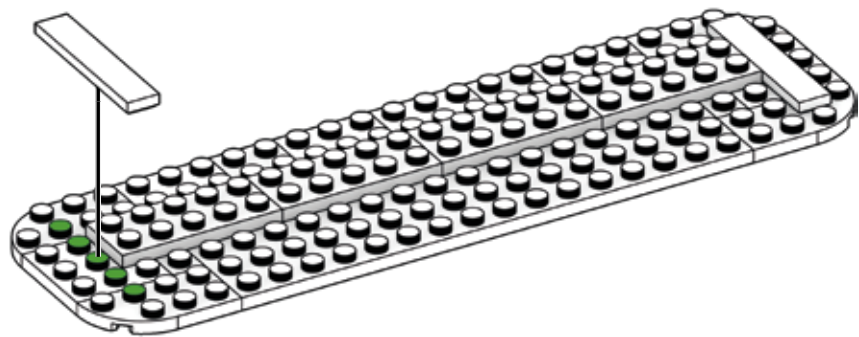

78



4x

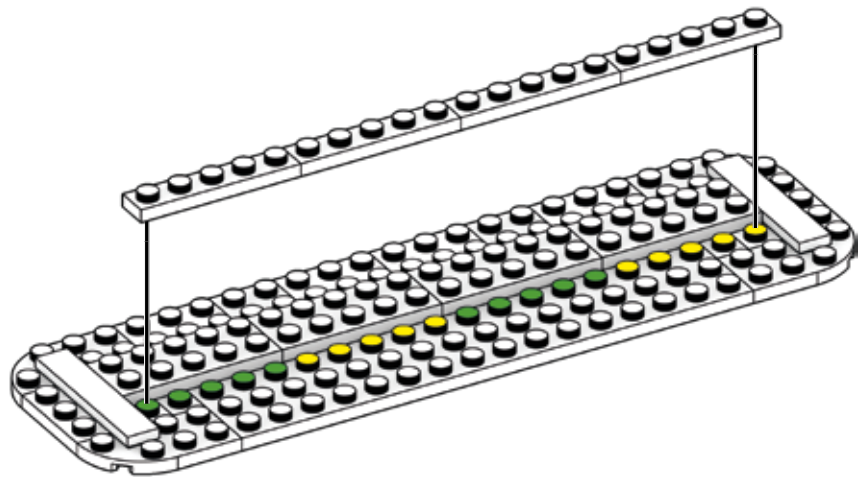

79



5x

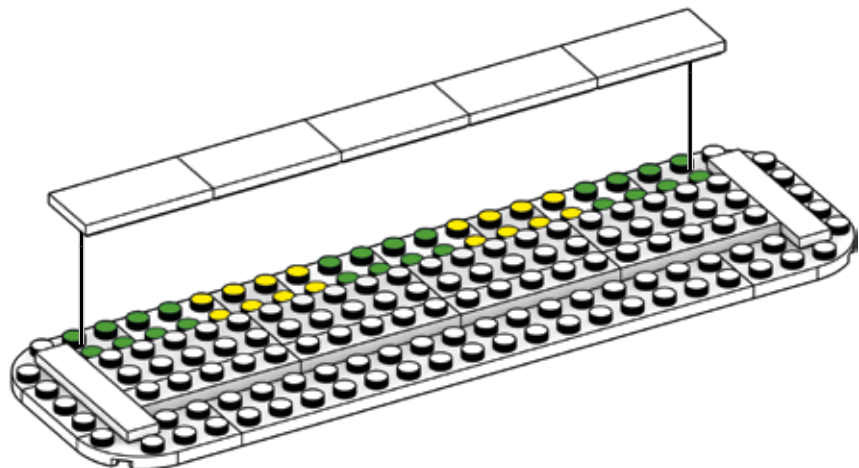

80



5x

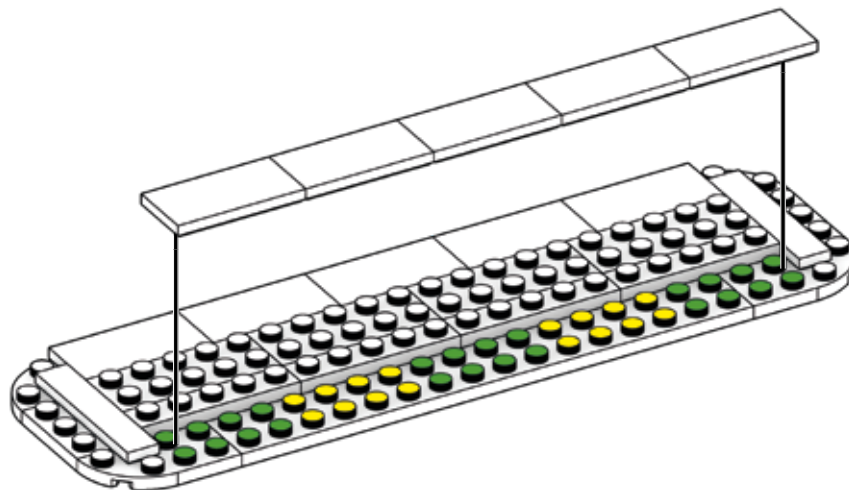

81



4x



2x

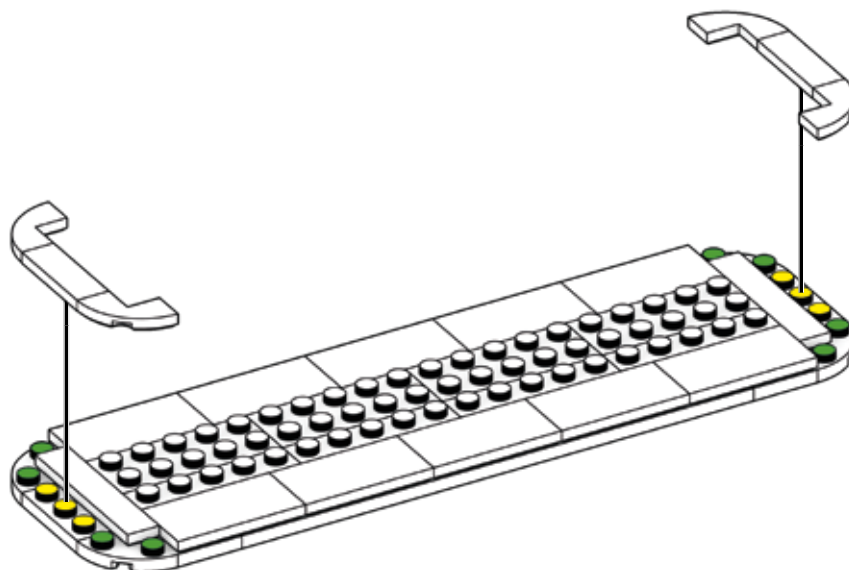

82



2x



1x

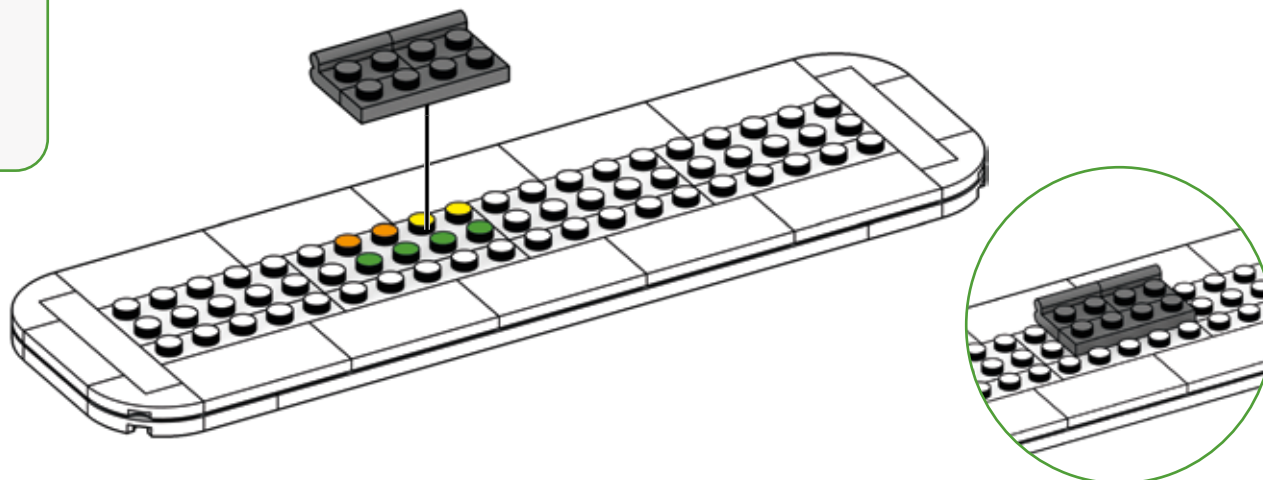

83

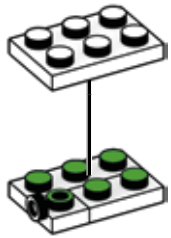
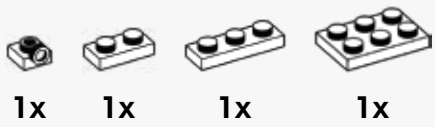

84

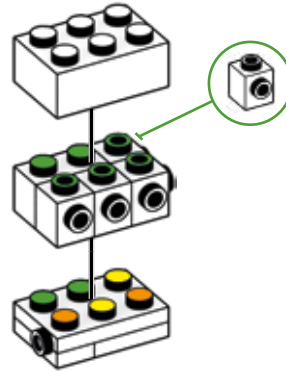
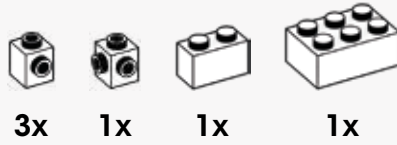

85

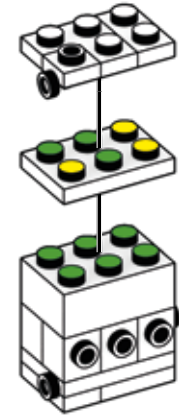
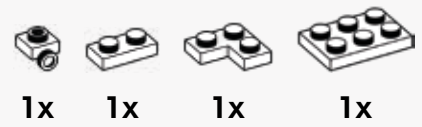

86

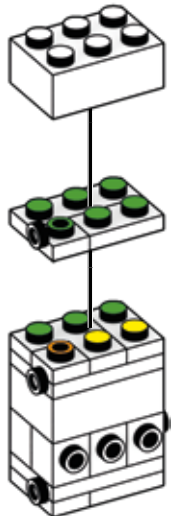
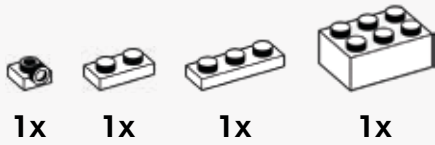

87

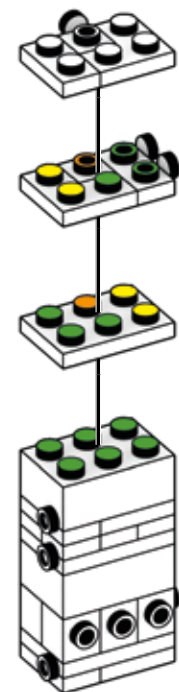
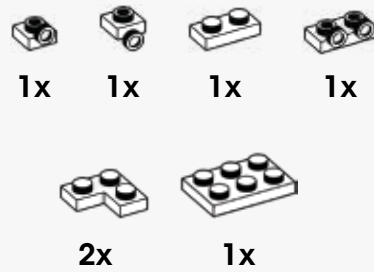

1

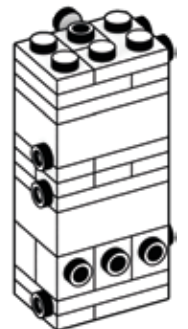

2

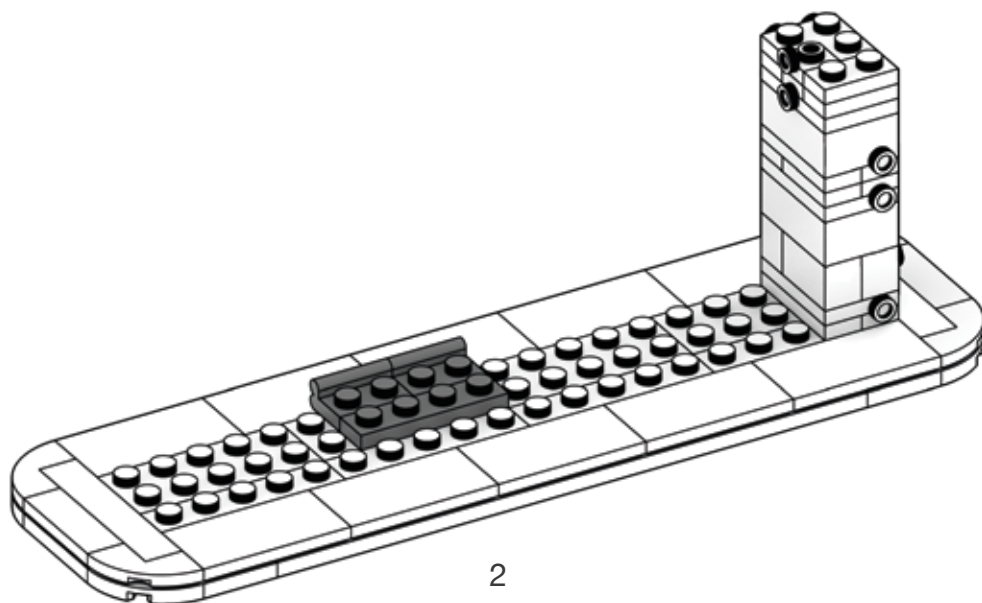
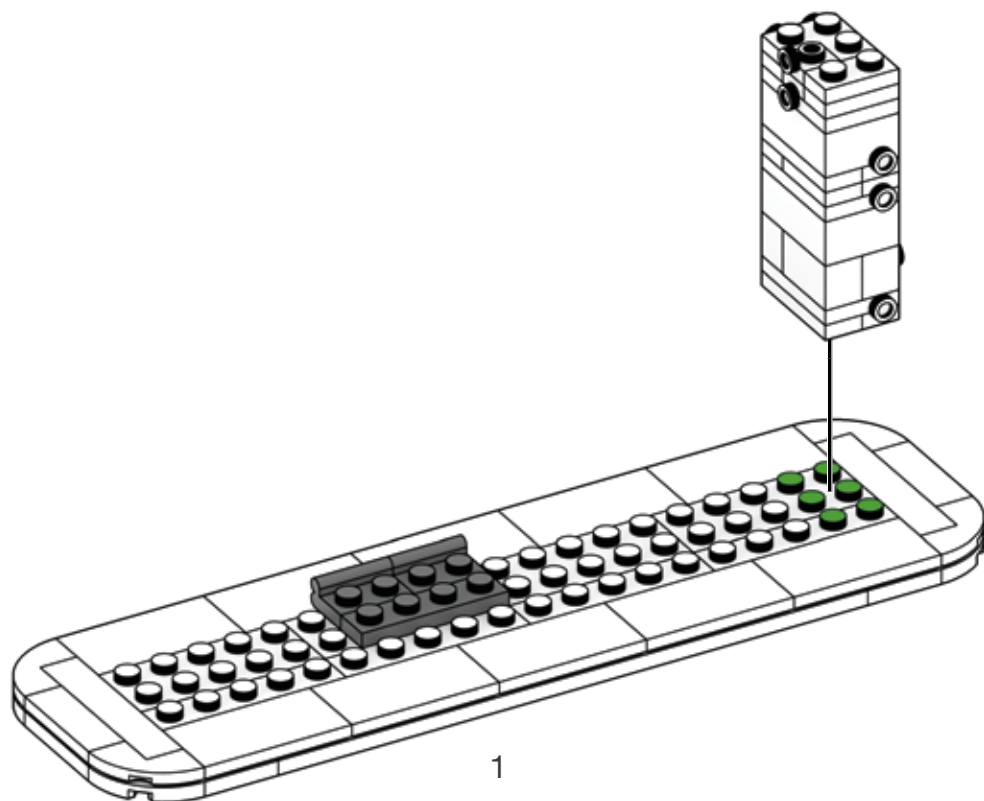

89

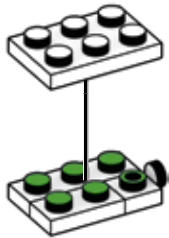
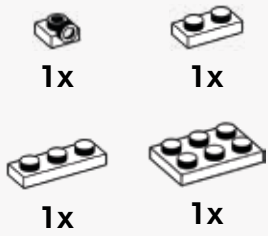

90

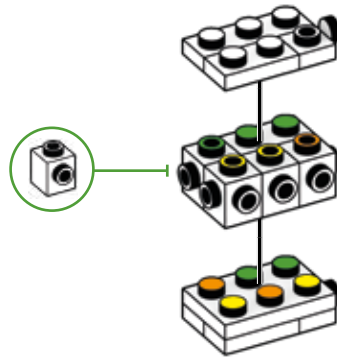
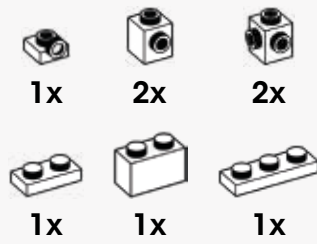

91

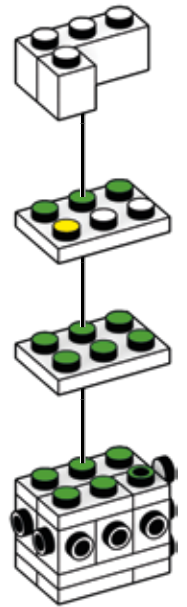
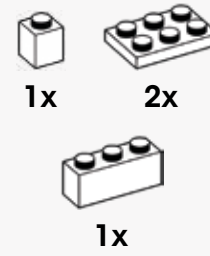

92

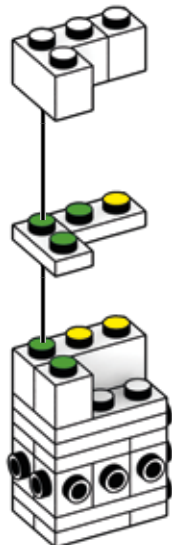
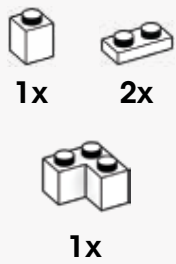

93

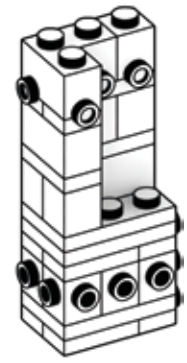
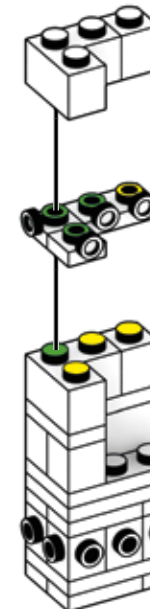
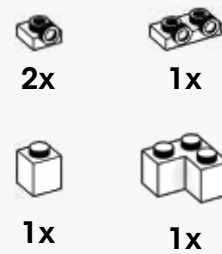

1

2

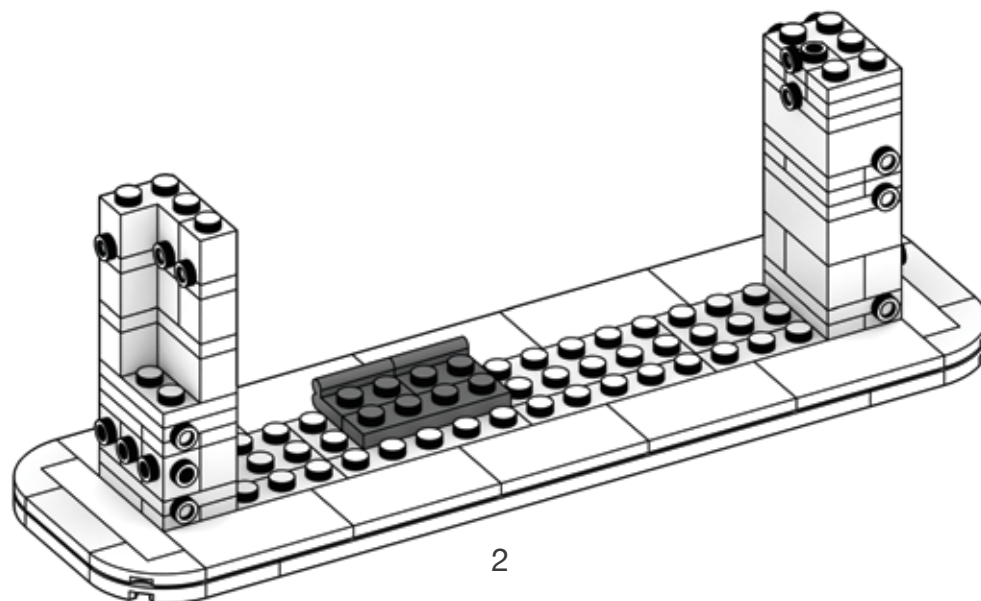
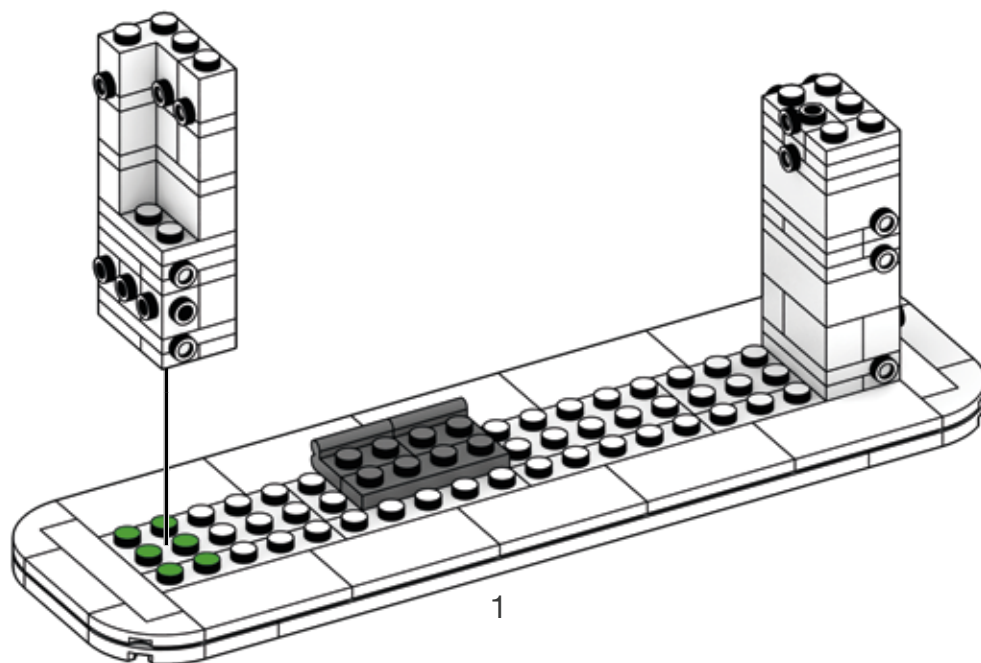

95



2x



1x

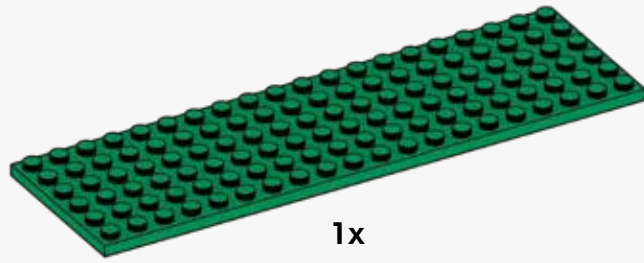

1x

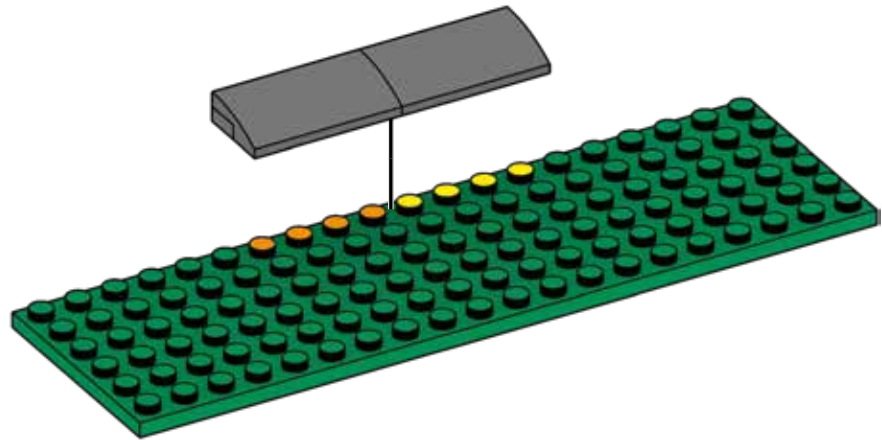
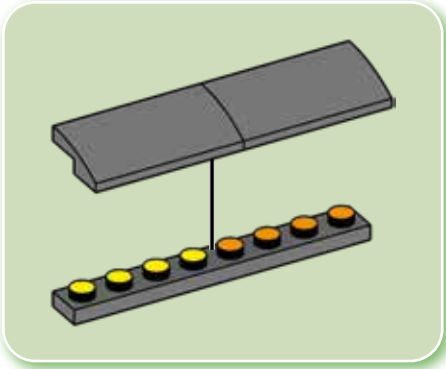

96



4x



1x

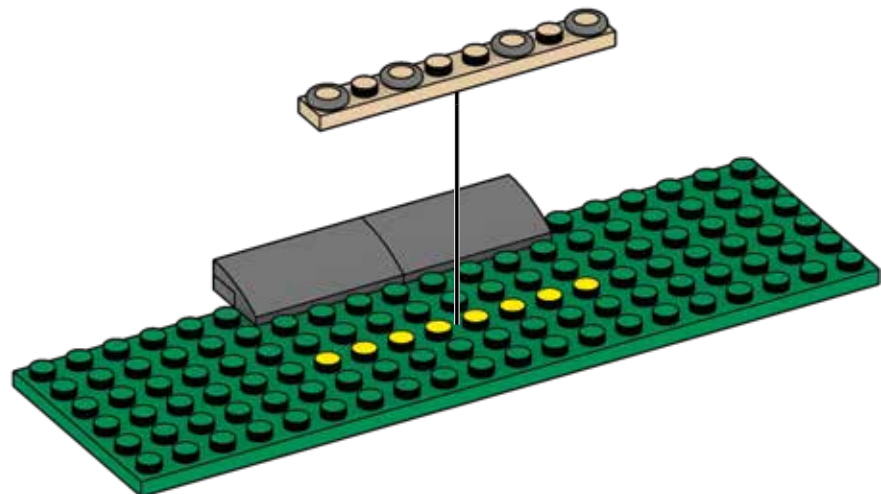
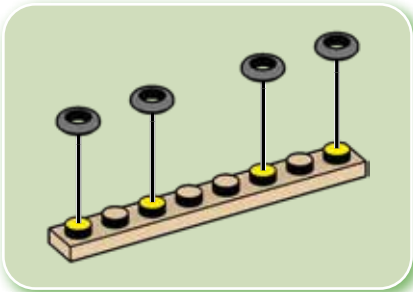

97



3x

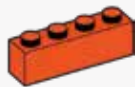

3x

x3

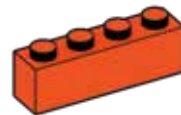
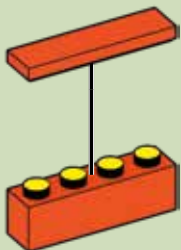

Place temporary pieces.
 Placer les pièces temporaires.
 Colocar las piezas provisionales.
 Colocar as peças temporárias.
 Posizionare i pezzi provvisori.
 Die vorübergehend benötigten Teile platzieren.
 Umieść tymczasowe elementy.
 Plaats tijdelijke delen.
 Поместите временные детали.
 Placer midlertidige stykker.
 Placera temporära delar.
 Placser midlertidige deler.
 Aseta väliaikaiset osat.
 Τοποθετήστε το προσωρινό κομμάτι.
 Geçici parçaları yerleştirin.
 Umístěte dočasné díly.
 Vložte dočasné kusy.
 Helyezze el az ideiglenes darabokat.
 暫定ピースを配置してください。
 ضع القطع المؤقت.
 放置临时件

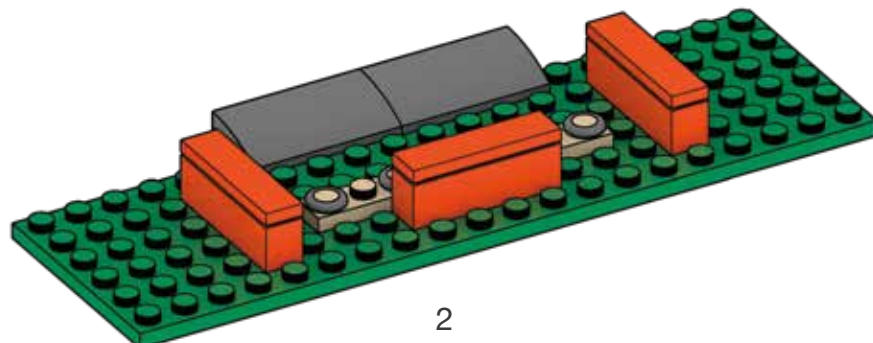
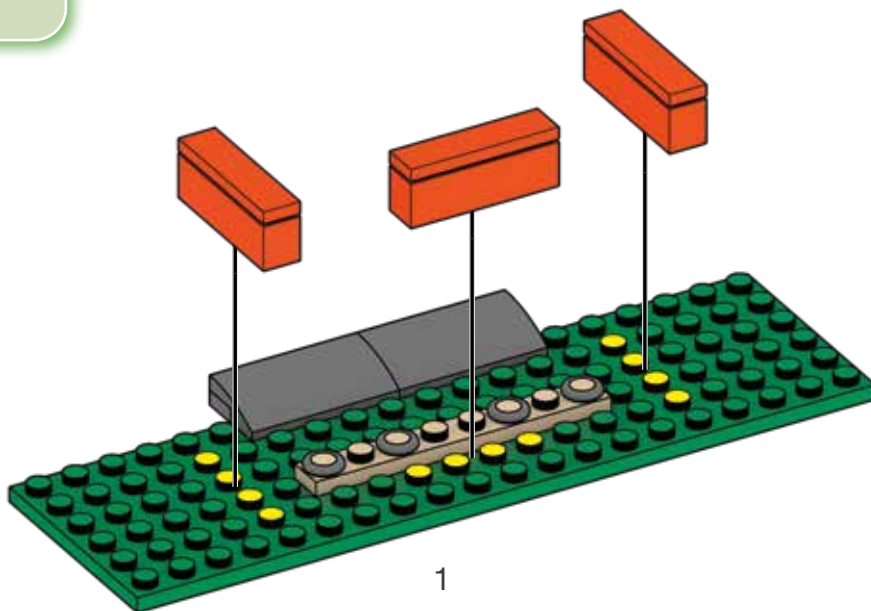

98

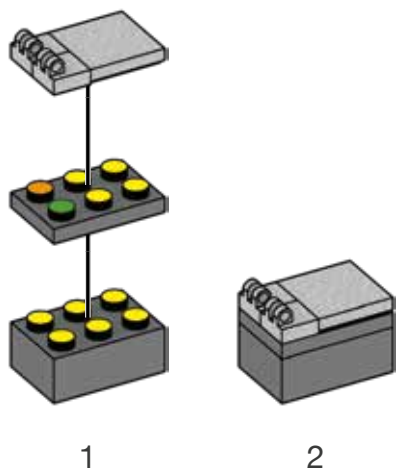
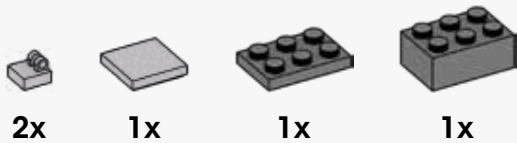

99

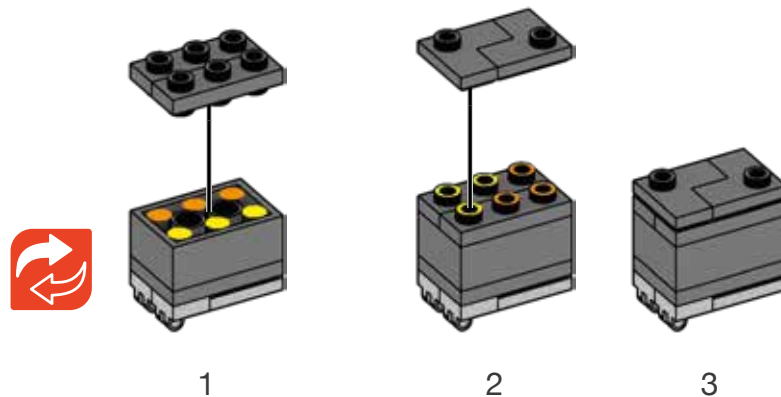

100

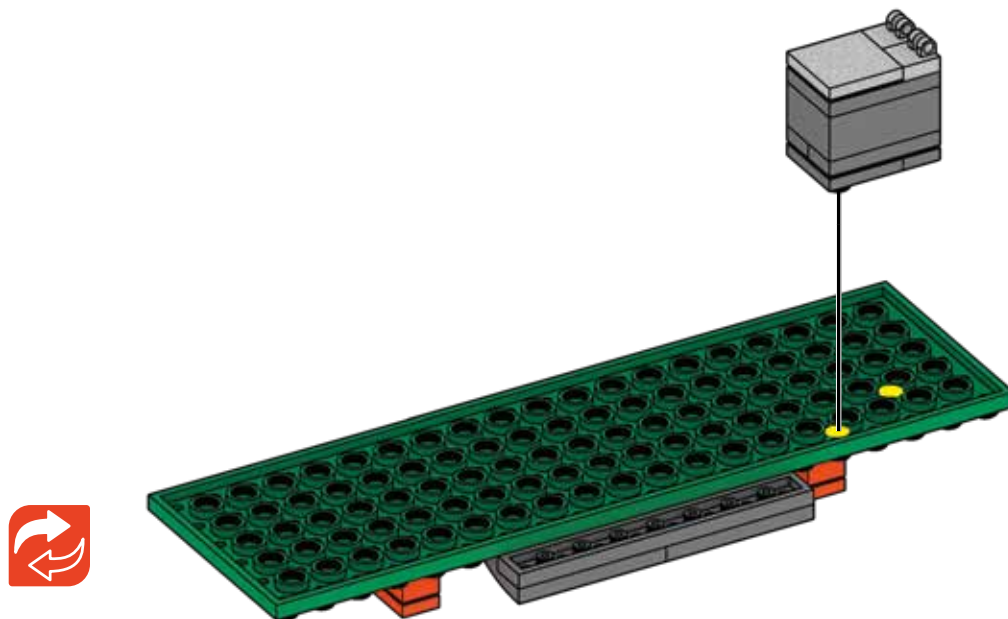

101



2x



2x



1x

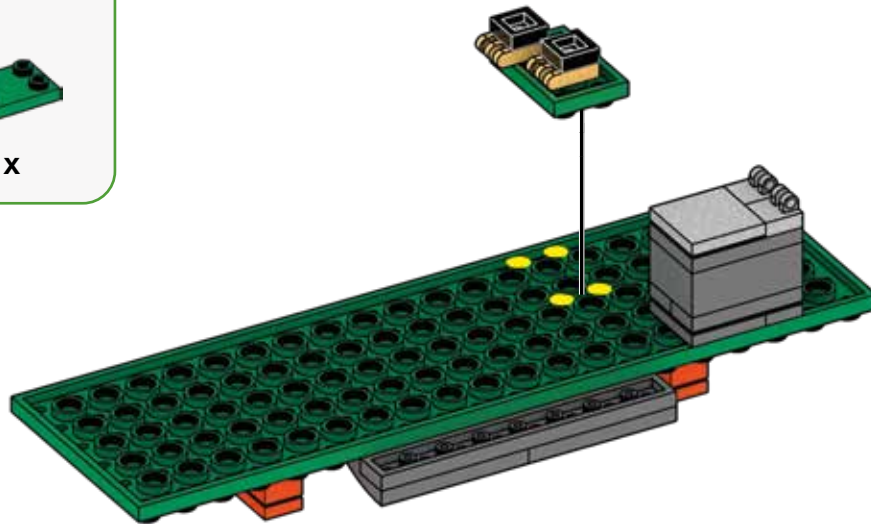
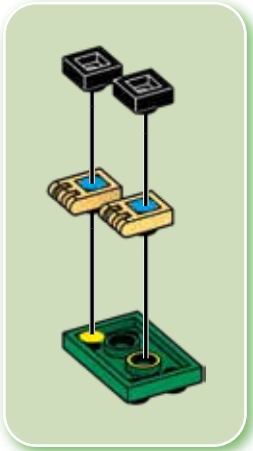

1

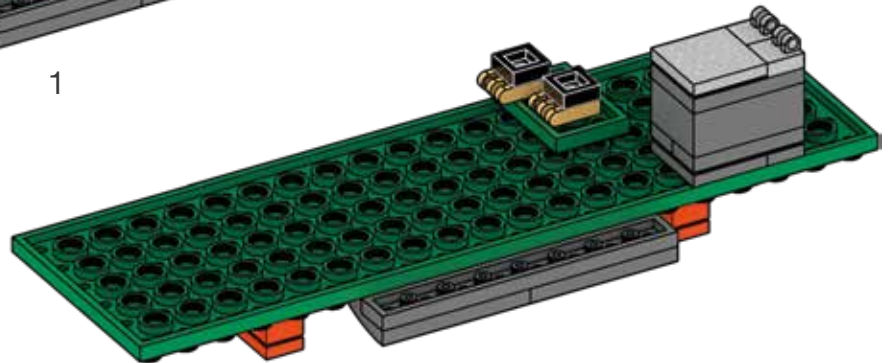

2

102



8x



4x



1x

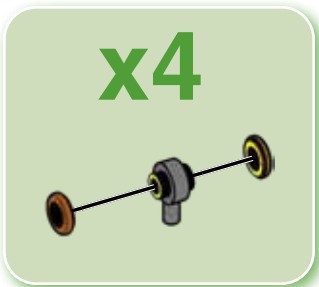

103



1x

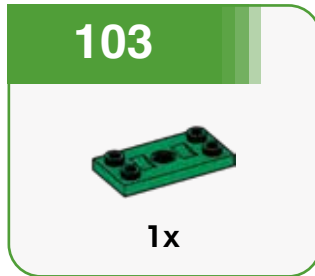

104



2x



2x

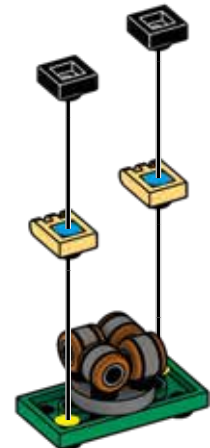
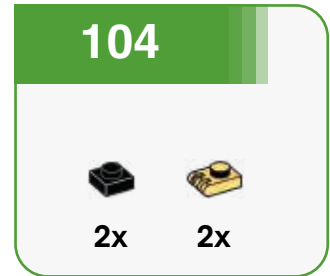

105

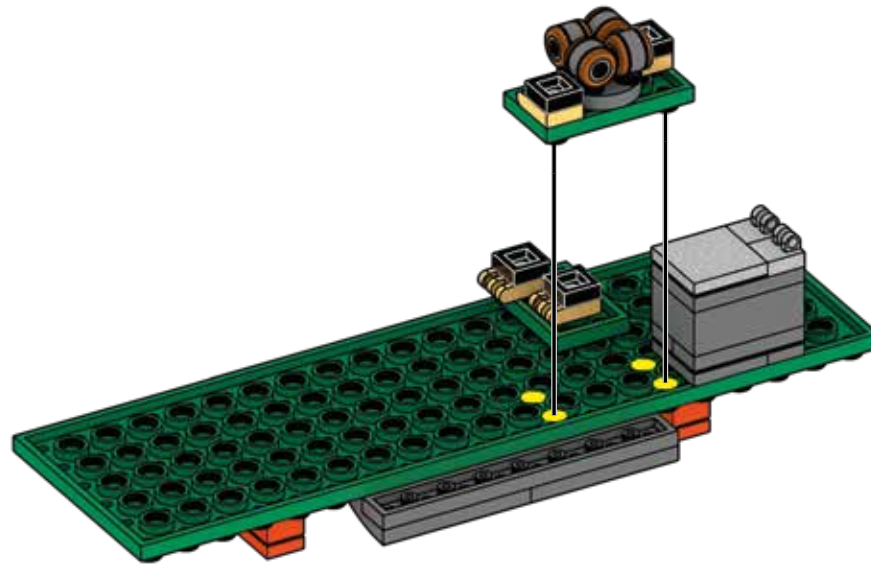

106

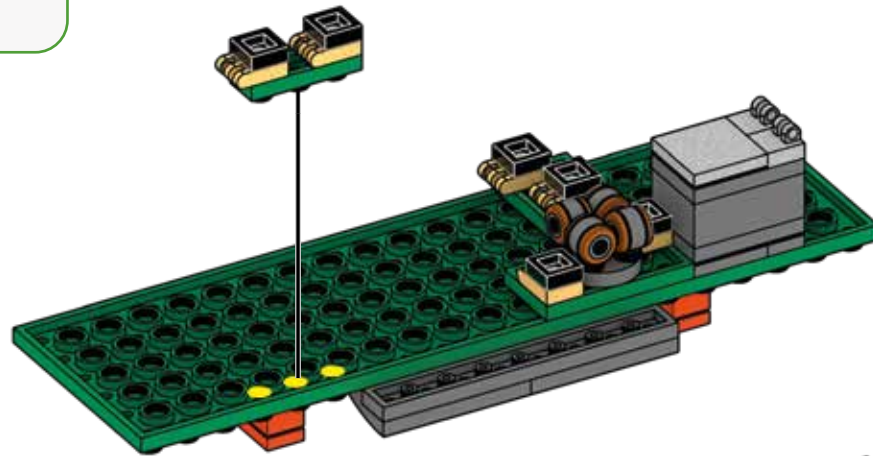
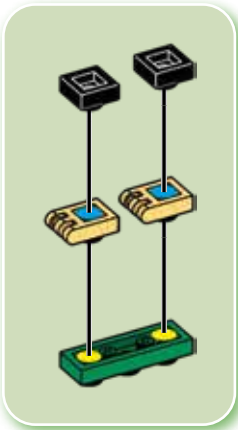
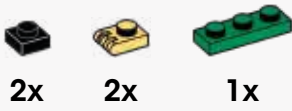

1

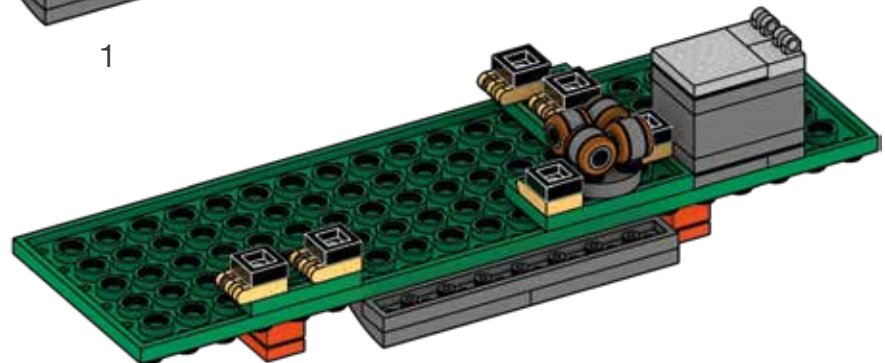

2

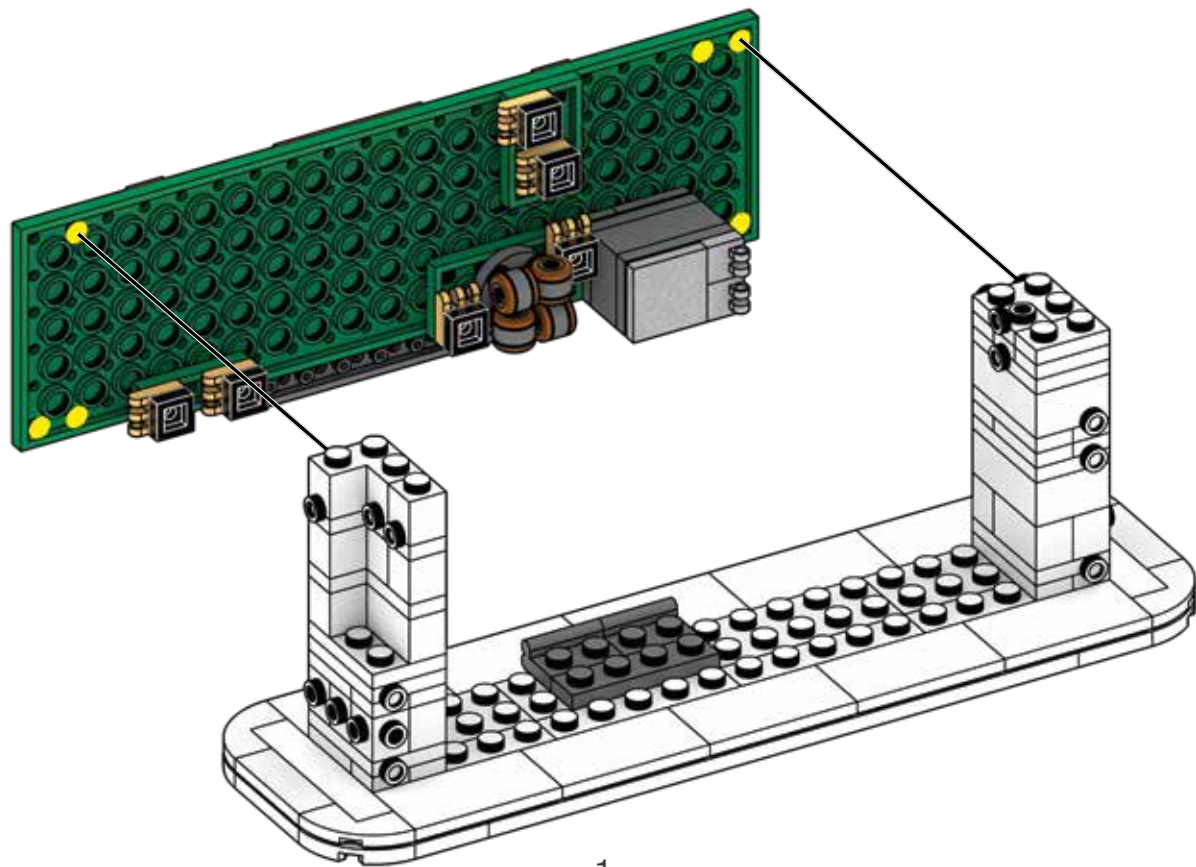

1

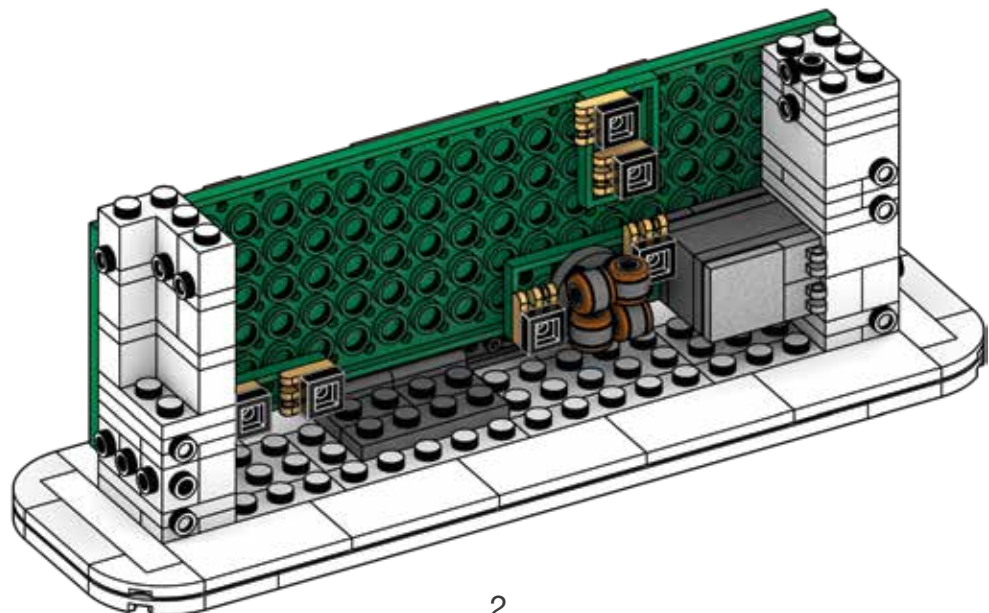

2



108



3x 1x 1x

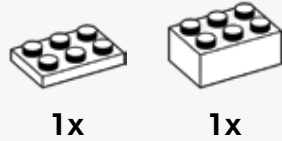

1x 1x

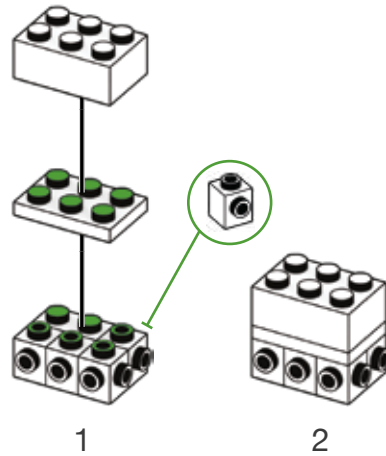

1 2

109

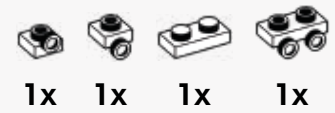

1x 1x 1x 1x



1x 1x

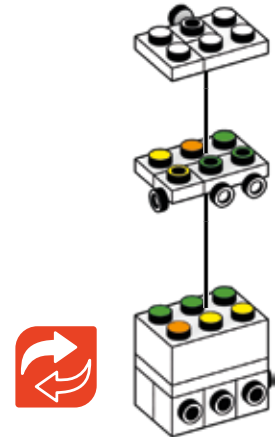

110

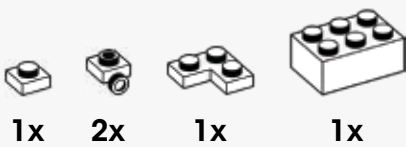

1x 2x 1x 1x

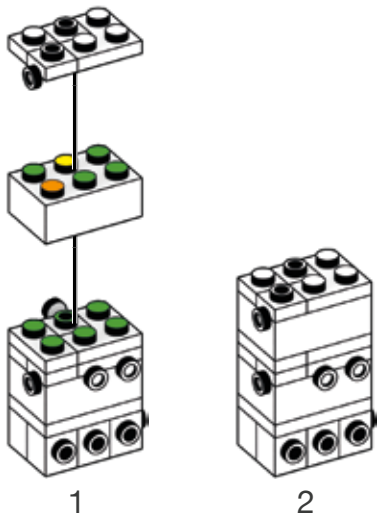

1 2

111

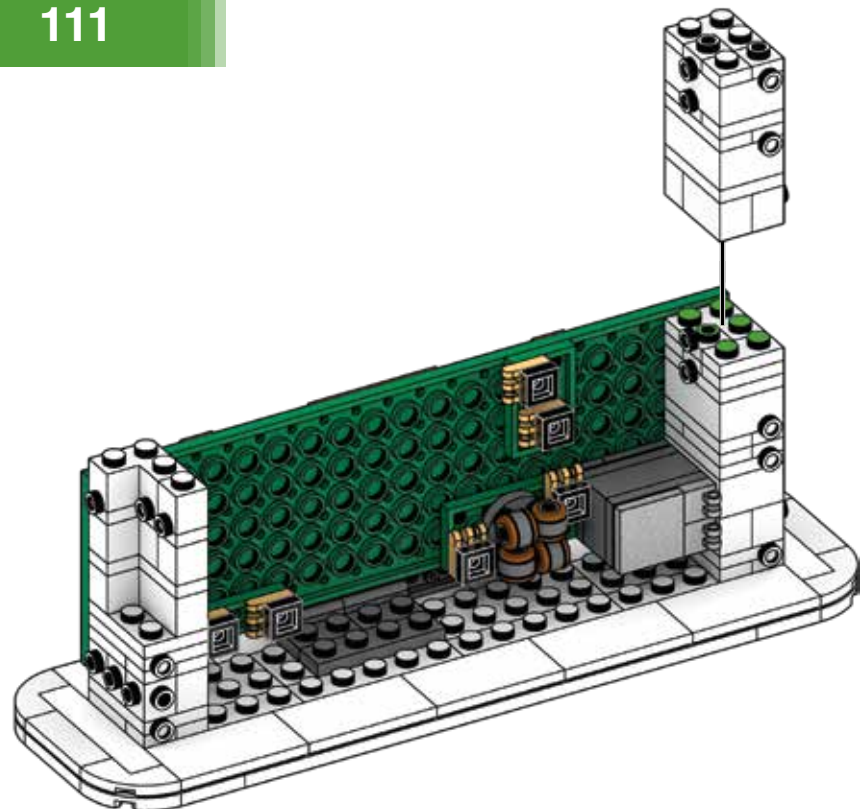

112



1x



1x

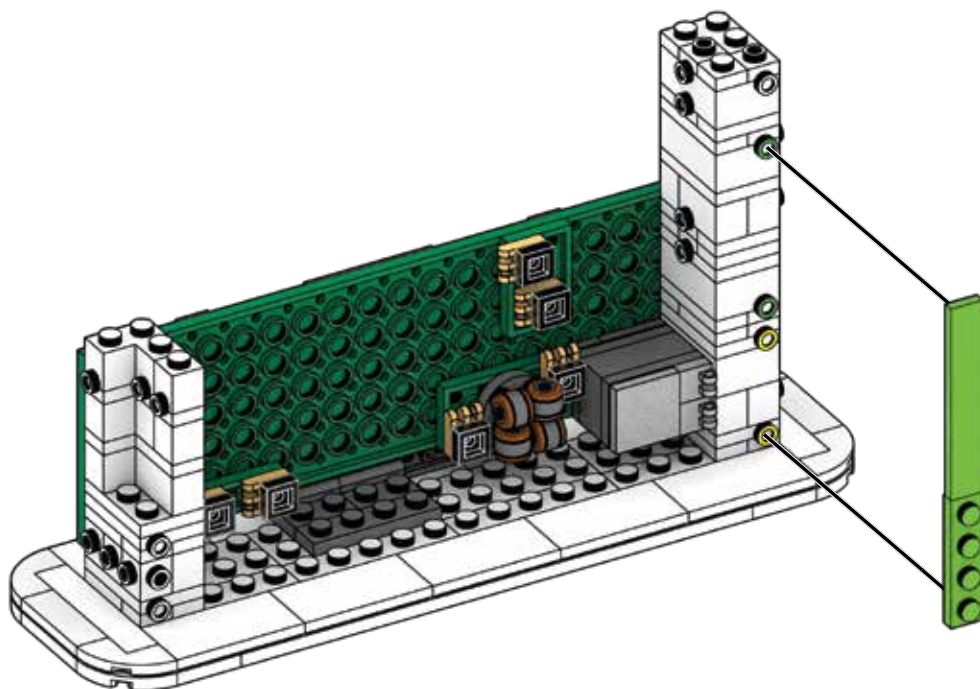

113



2x



1x

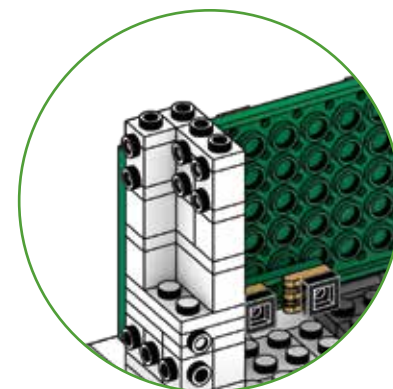
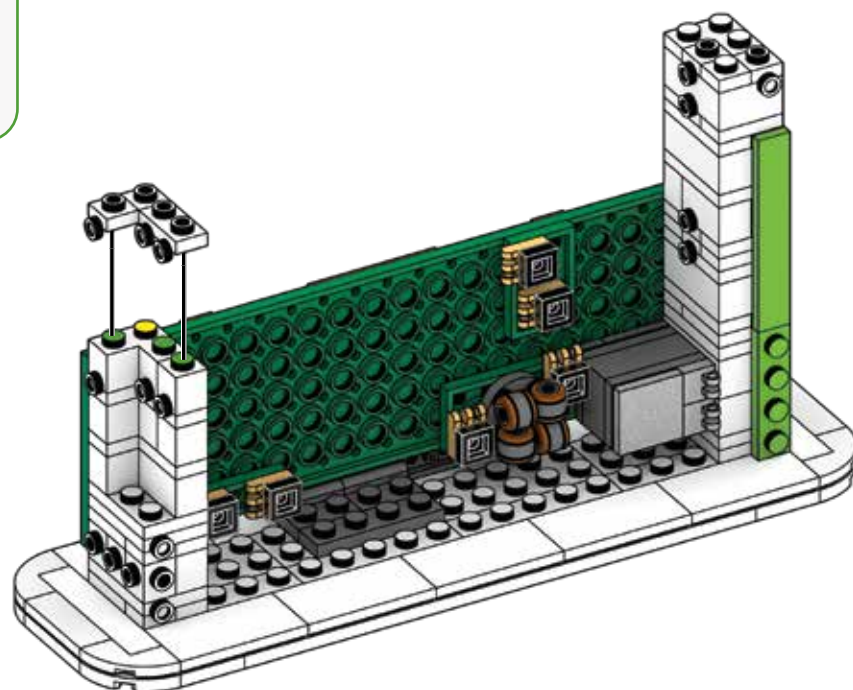

114



1x

1x



1x

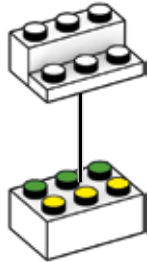

115



1x

1x



1x

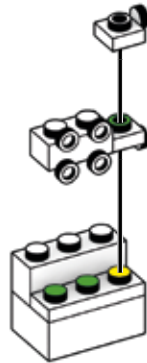

116



1x

1x

1x



1x

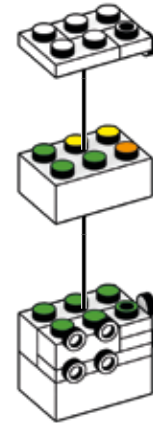

1

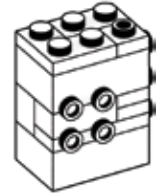

2

117

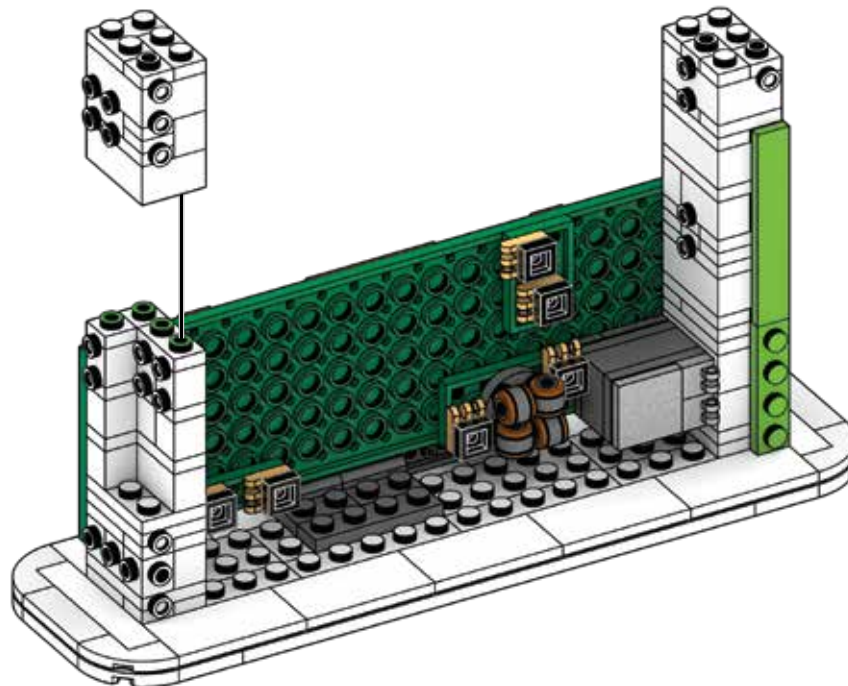

118



1x



1x

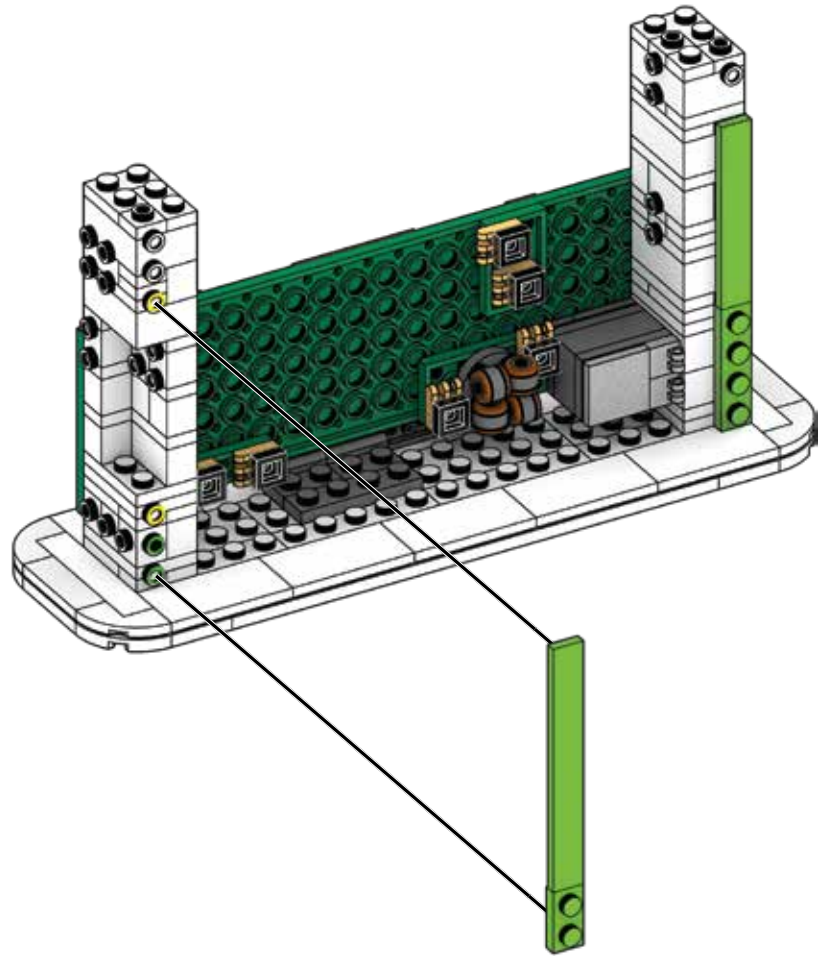

119



1x



1x



1x



1x

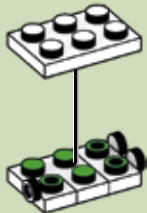

1

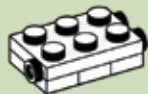

2

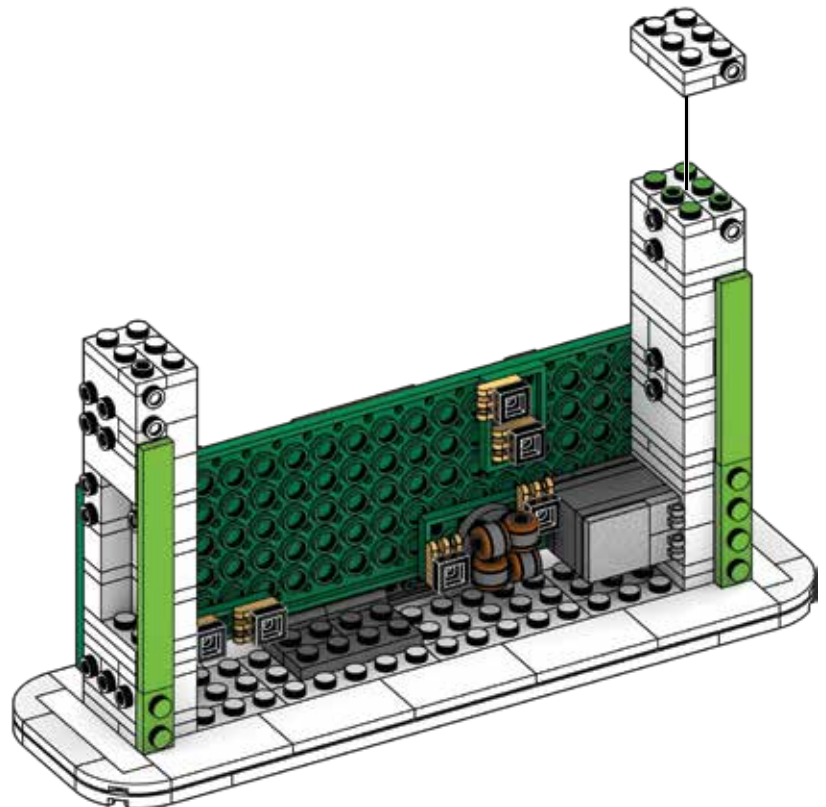

120



1x



1x



1x



1x



1



2

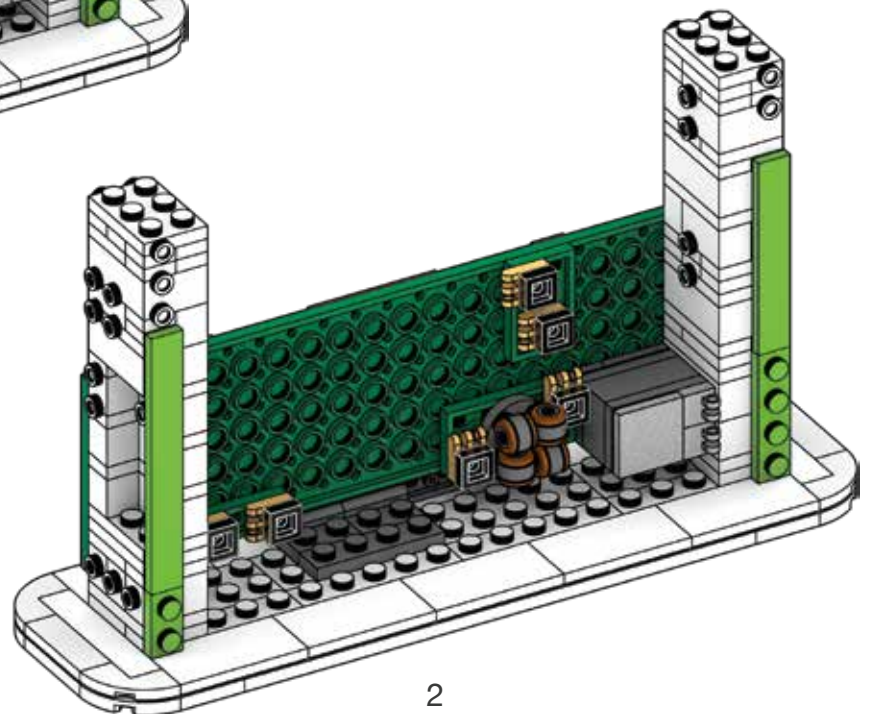
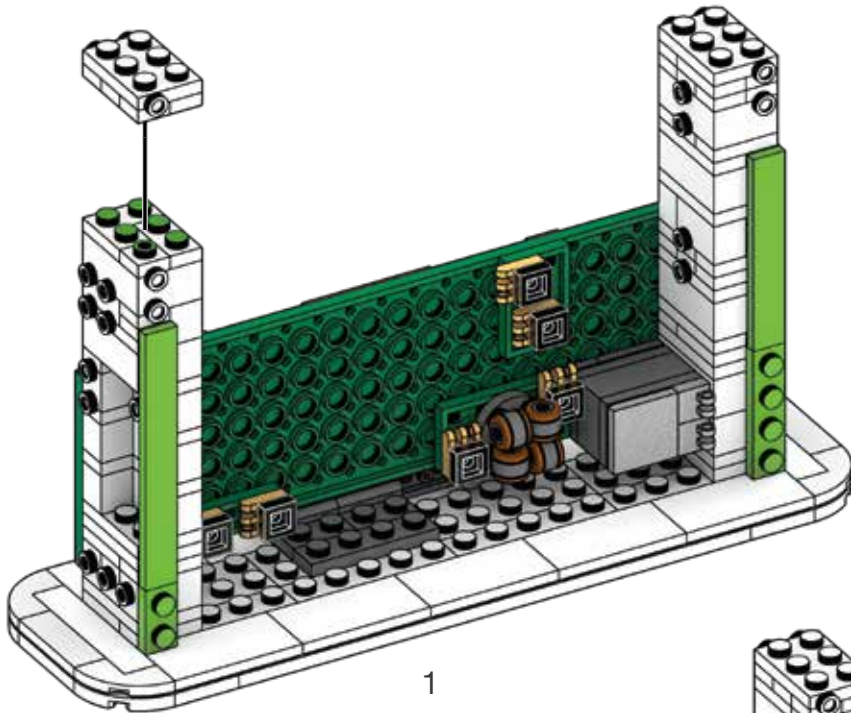

121

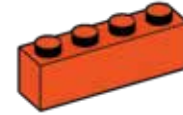
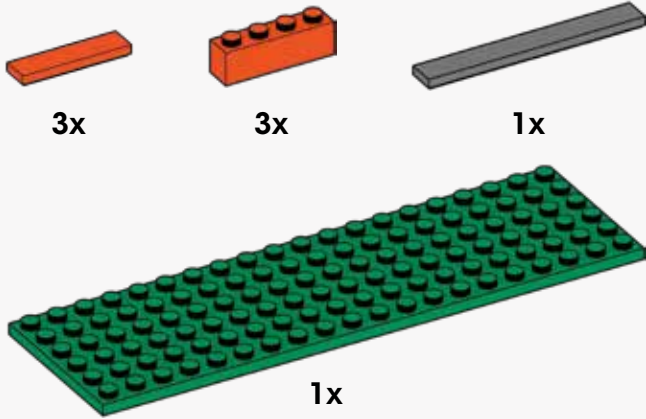

Place temporary pieces.
Placer les pièces temporaires.
Colocar las piezas provisionales.
Colocar as peças temporárias.
Posizionare i pezzi provvisori.
Die vorübergehend benötigten Teile platzieren.
Umieścić tymczasowe elementy.
Plaats tijdelijke delen.
Поместите временные детали.
Placer midlertidige stykker.
Placera temporära delar.
Plasser midlertidige deler.
Aseta väliaikaiset osat.
Τοποθετήστε το προσωρινό κομμάτι.
Geçici parçaları yerleştirin.
Umístěte dočasné díly.
Vložte dočasné kusy.
Helyezze el az ideiglenes darabokat.
暫定ピースを配置してください
ضع القطع المؤقتة
放置临时件

x3

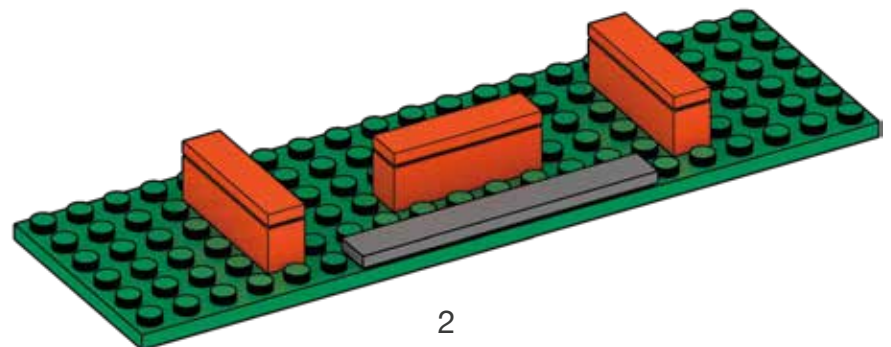
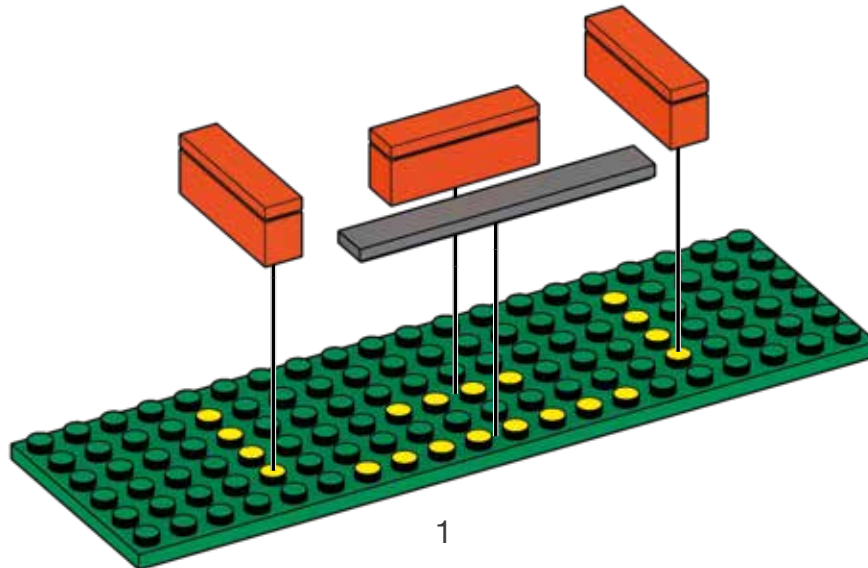

122

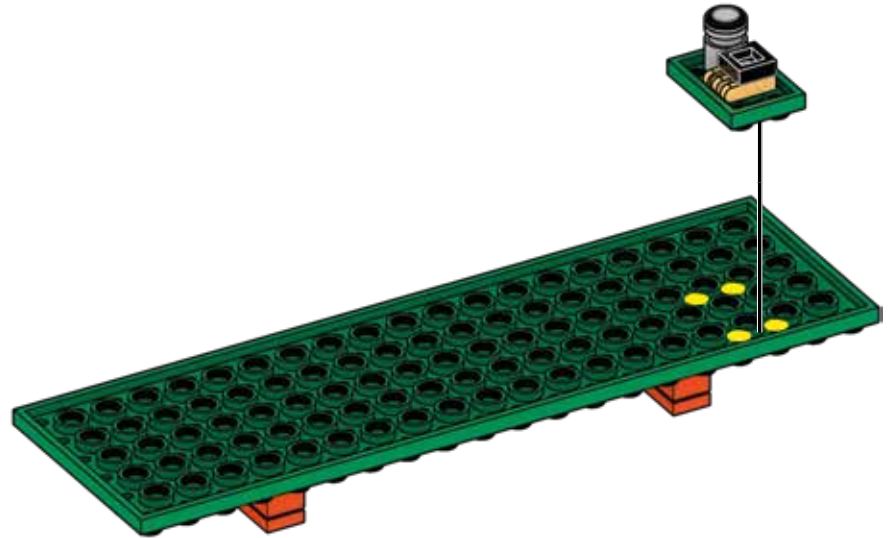
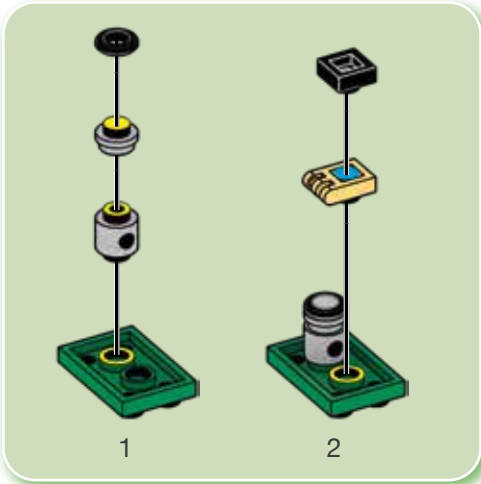
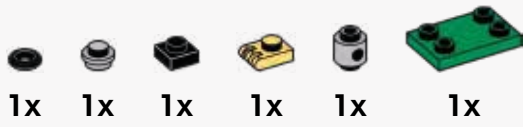

123

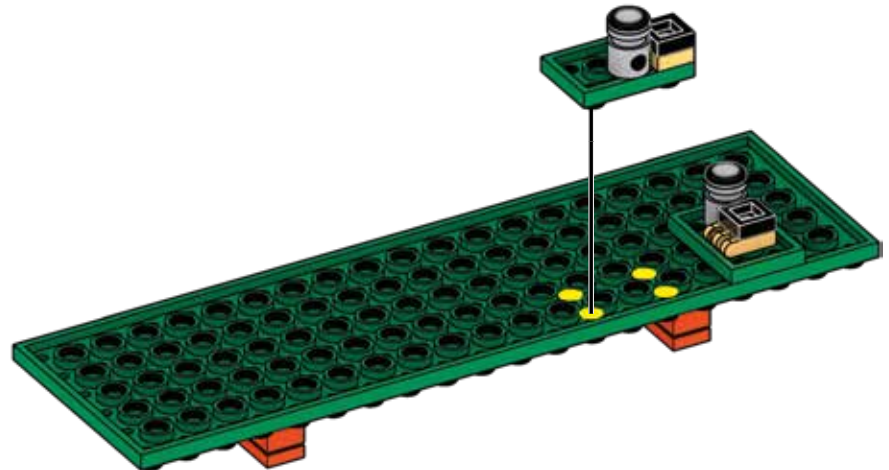
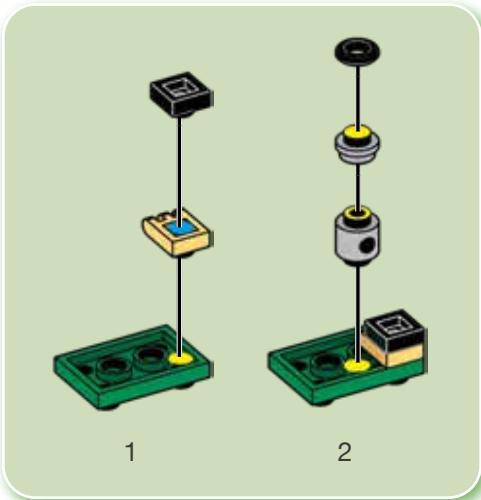

124

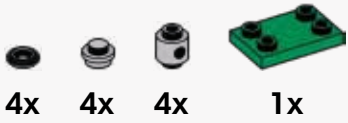

x4

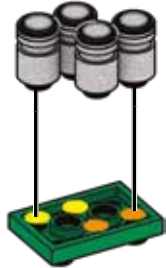

125

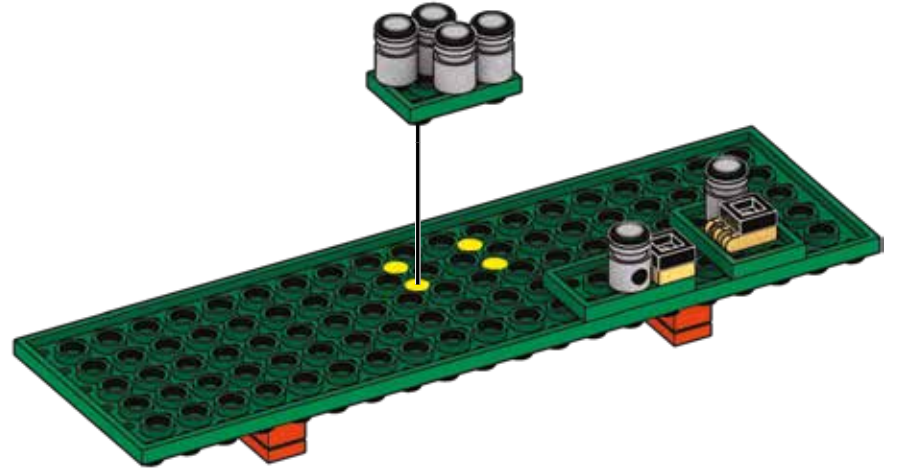

126



x4

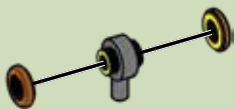

127

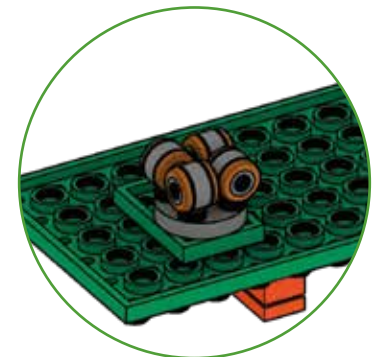
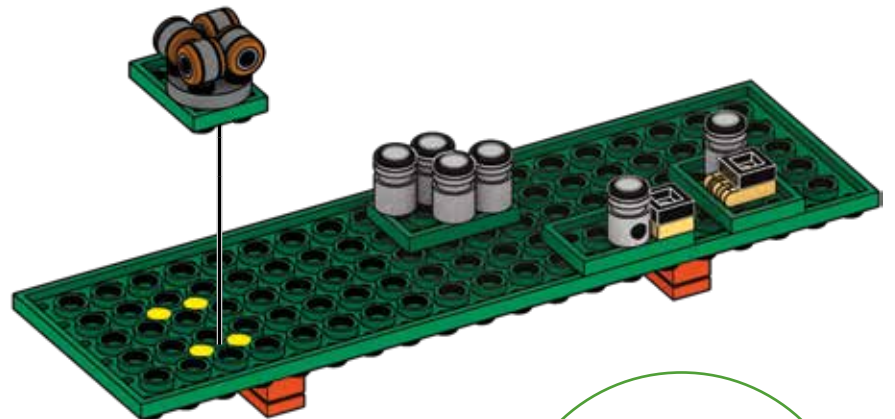

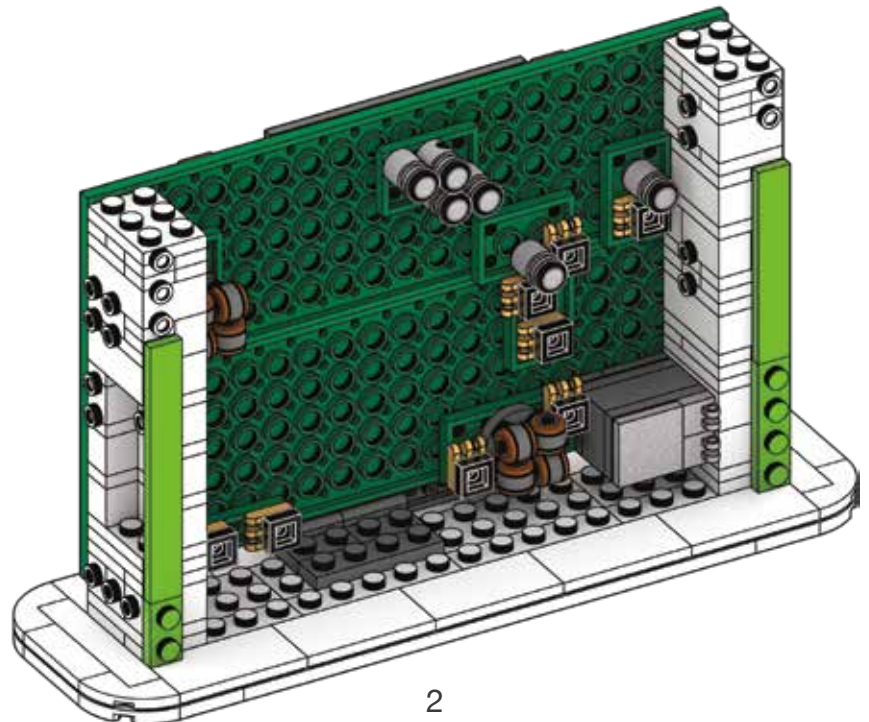
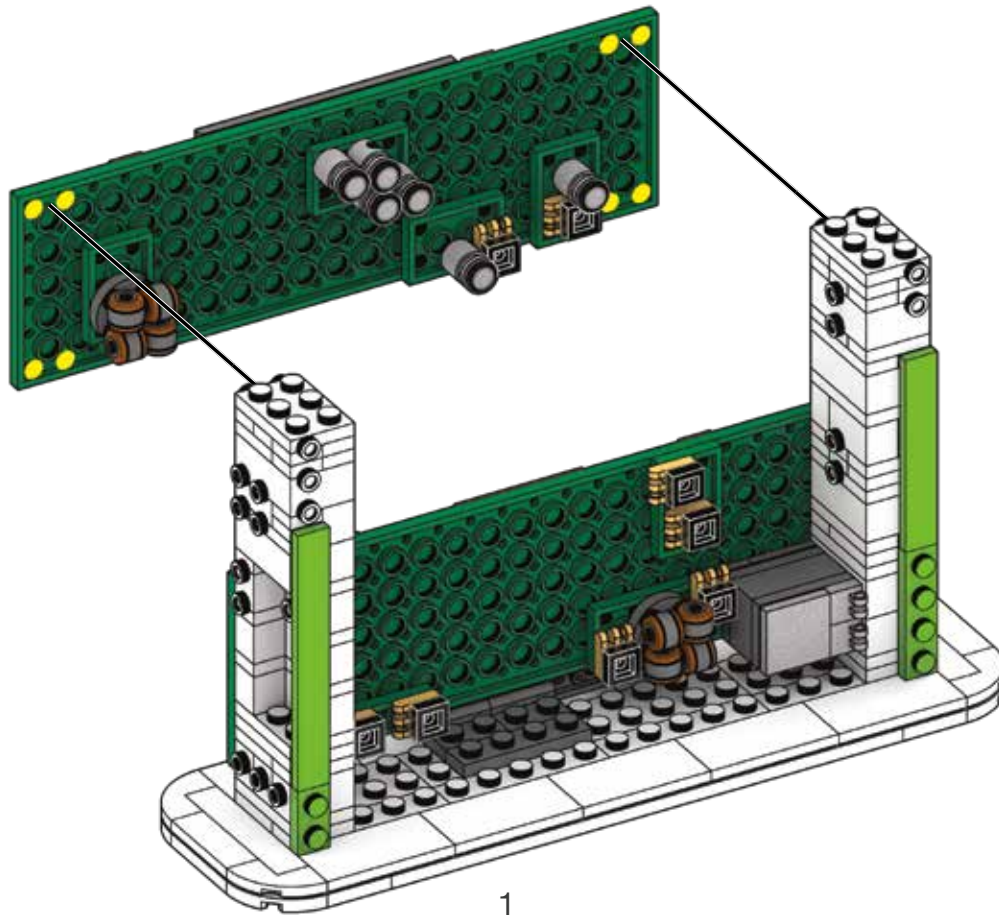

129



2x

2x

1x

1x

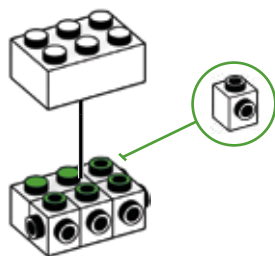

130



1x

1x

1x

1x

1x

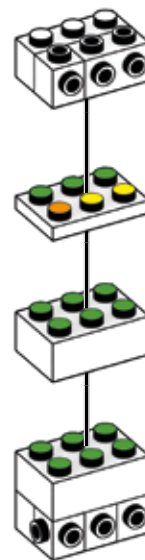

131



1x

1x

1x



1

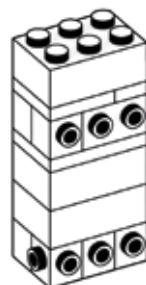

2

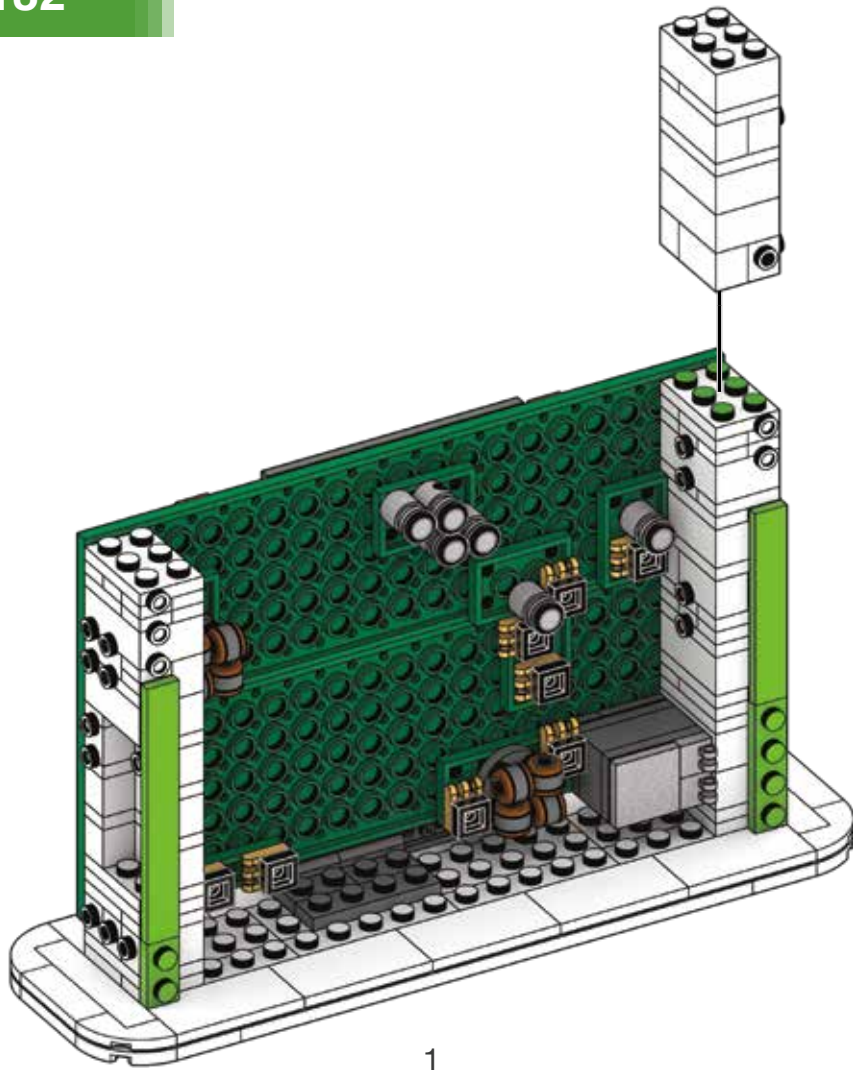

1

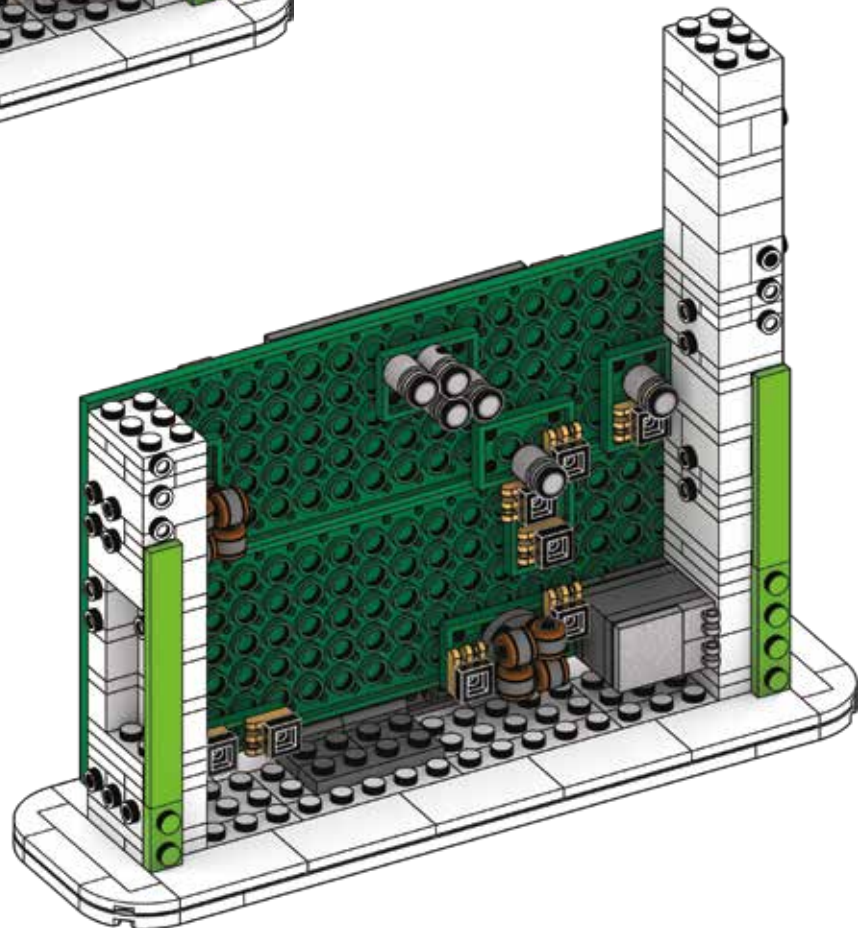

2

133

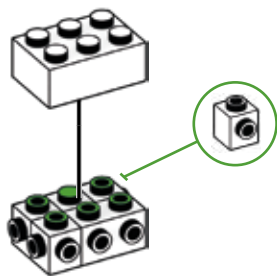
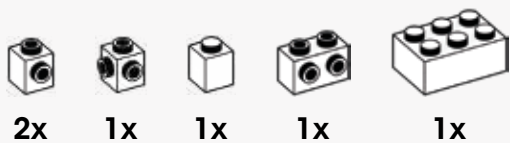

134

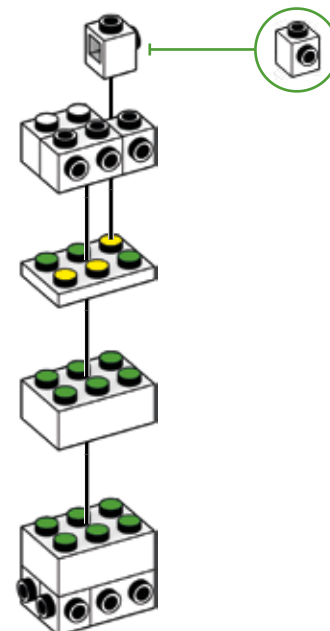
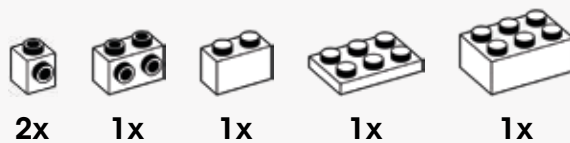

135

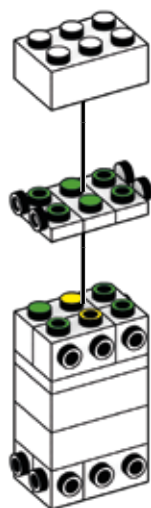

1

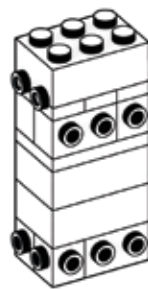

2

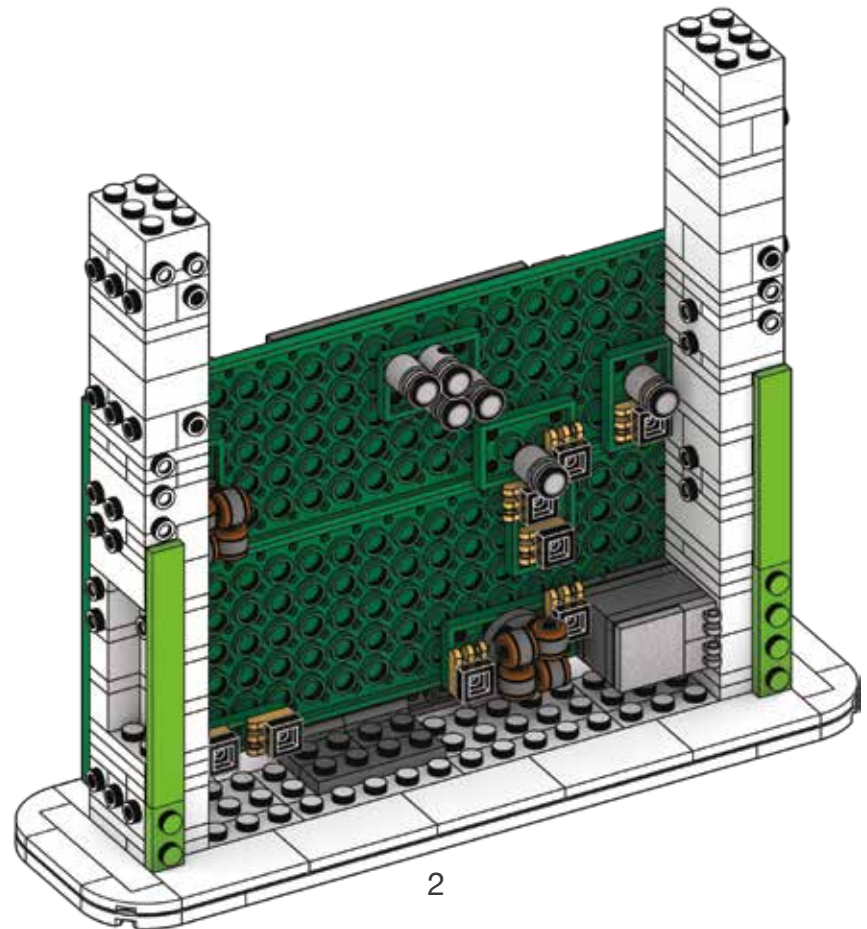
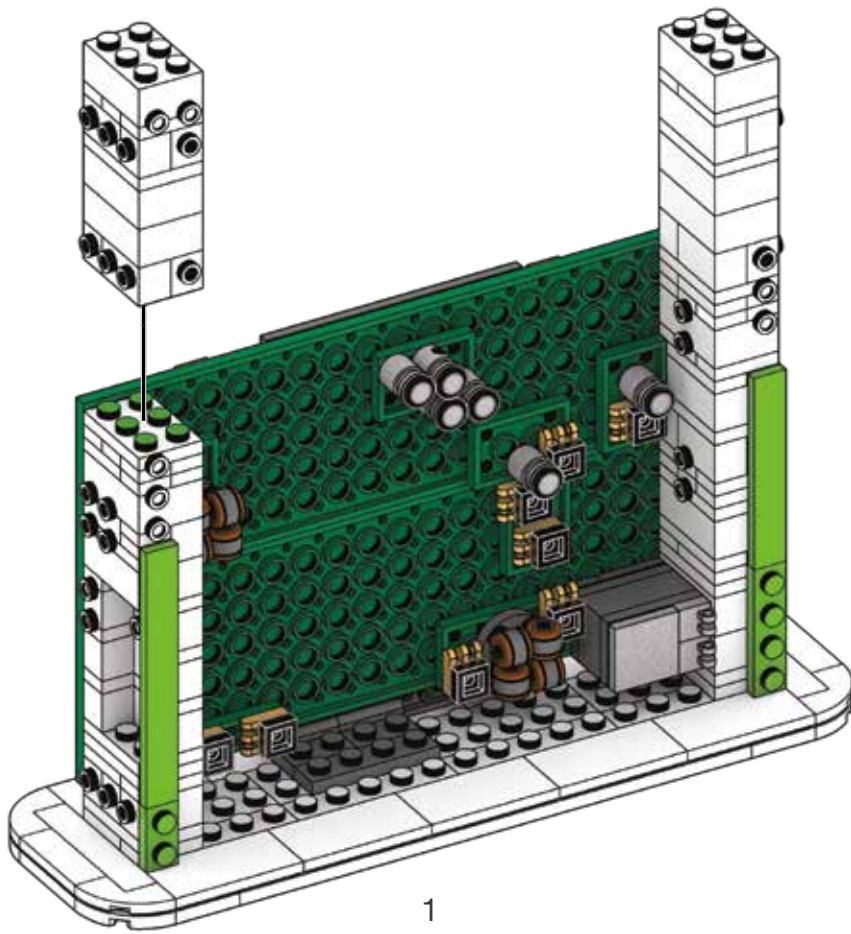

137



3x

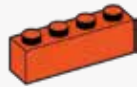

3x

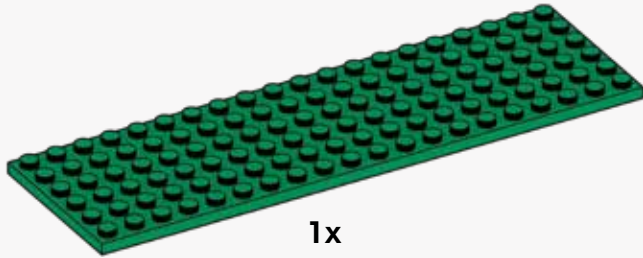

1x

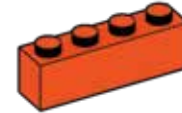

Place temporary pieces.
 Placer les pièces temporaires.
 Colocar las piezas provisionales.
 Colocar as peças temporárias.
 Posizionare i pezzi provvisori.
 Die vorübergehend benötigten Teile platzieren.
 Umieść tymczasowe elementy.
 Plaats tijdelijke delen.
 Поместите временные детали.
 Placer midlertidige stykker.
 Placera temporära delar.
 Plasser midlertidige deler.
 Aseta väliaikaiset osat.
 Τοποθετήστε τα προσωρινά κομμάτια.
 Geçici parçaları yerleştirin.
 Umístěte dočasné díly.
 Vložte dočasné kusy.
 Helyezze el az ideiglenes darabokat.
 暫定ピースを配置してください
 وضع القطع المؤقت
 放置临时件

x3

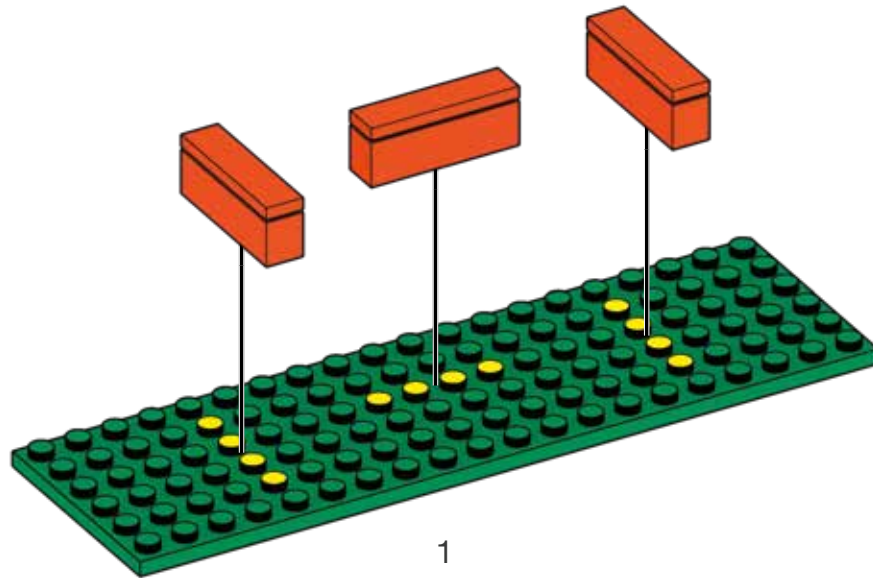
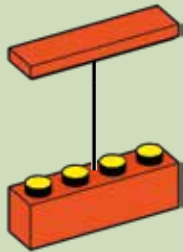

1

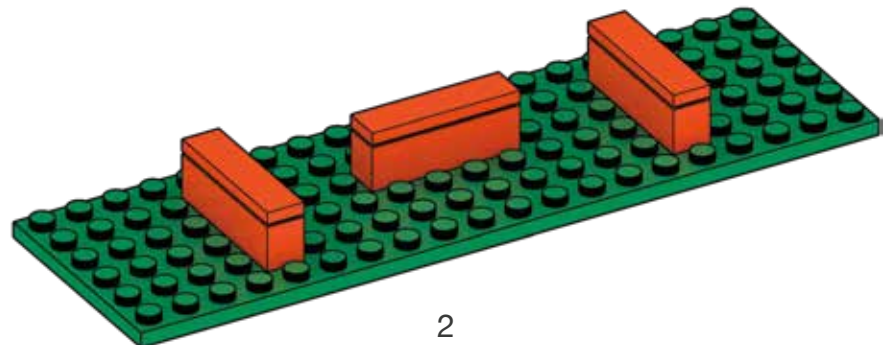

2

138

- 1x 
- 1x 
- 1x 
- 1x 
- 1x 
- 1x 

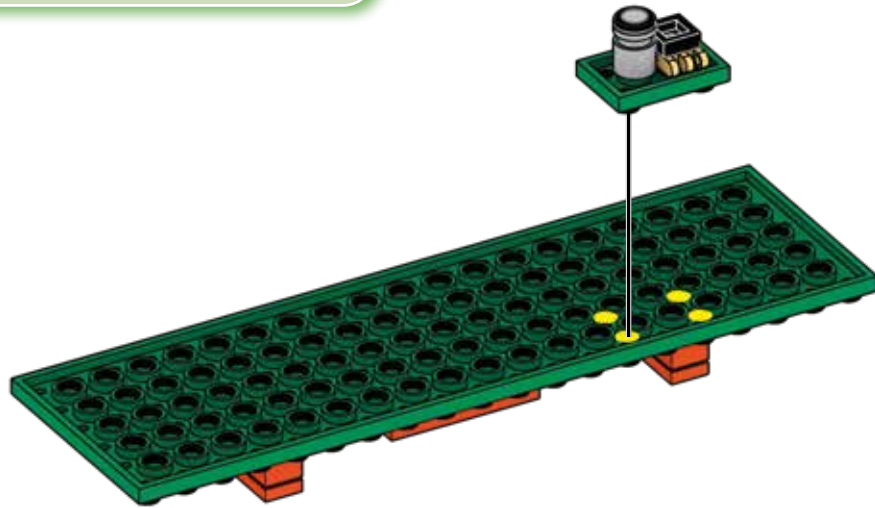
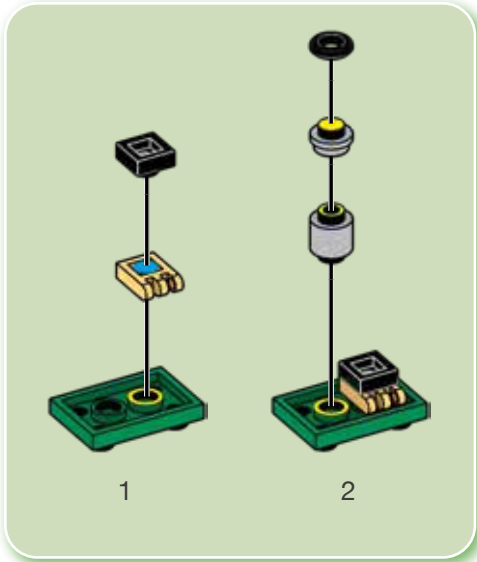

1

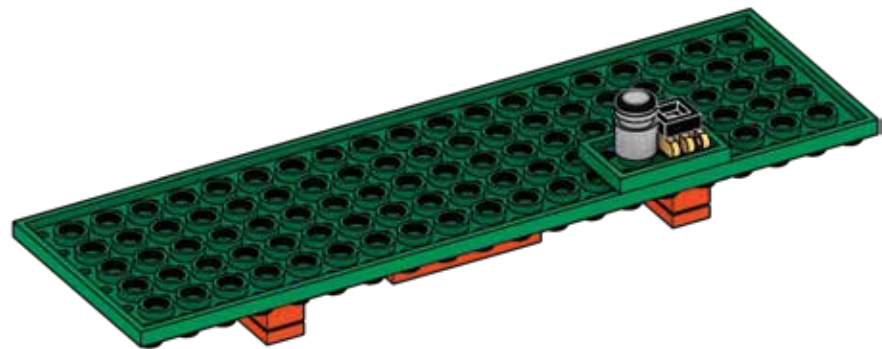

2

139

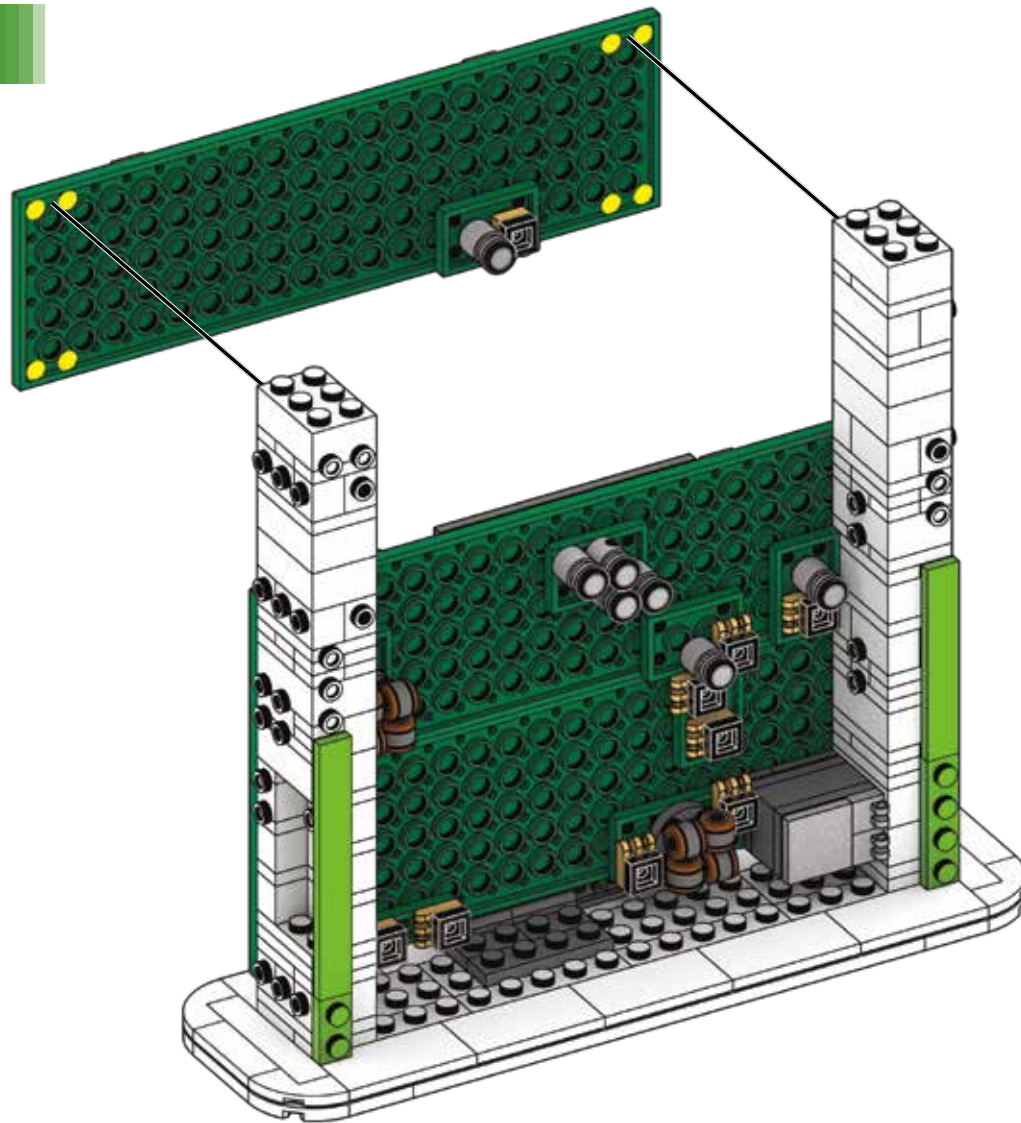

140



1x

1x

3x

1x

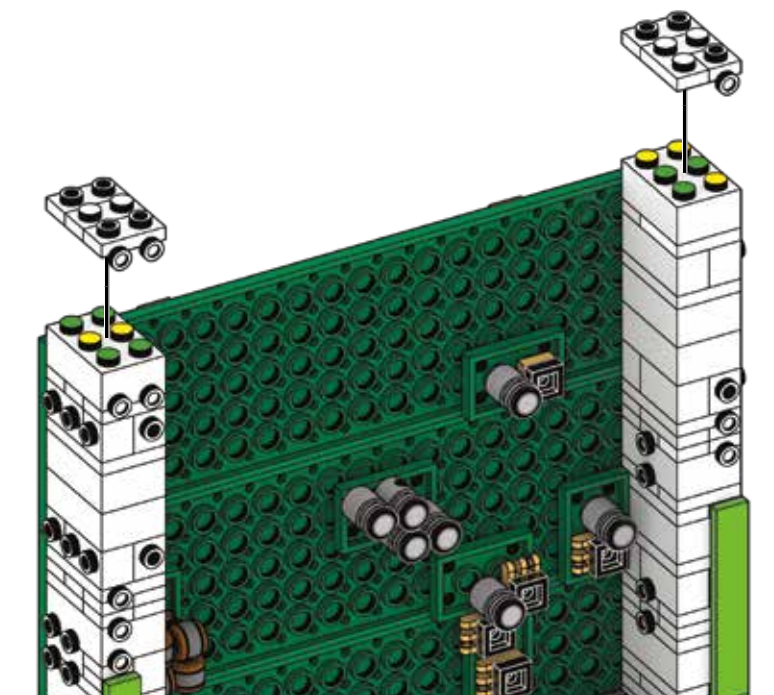

141

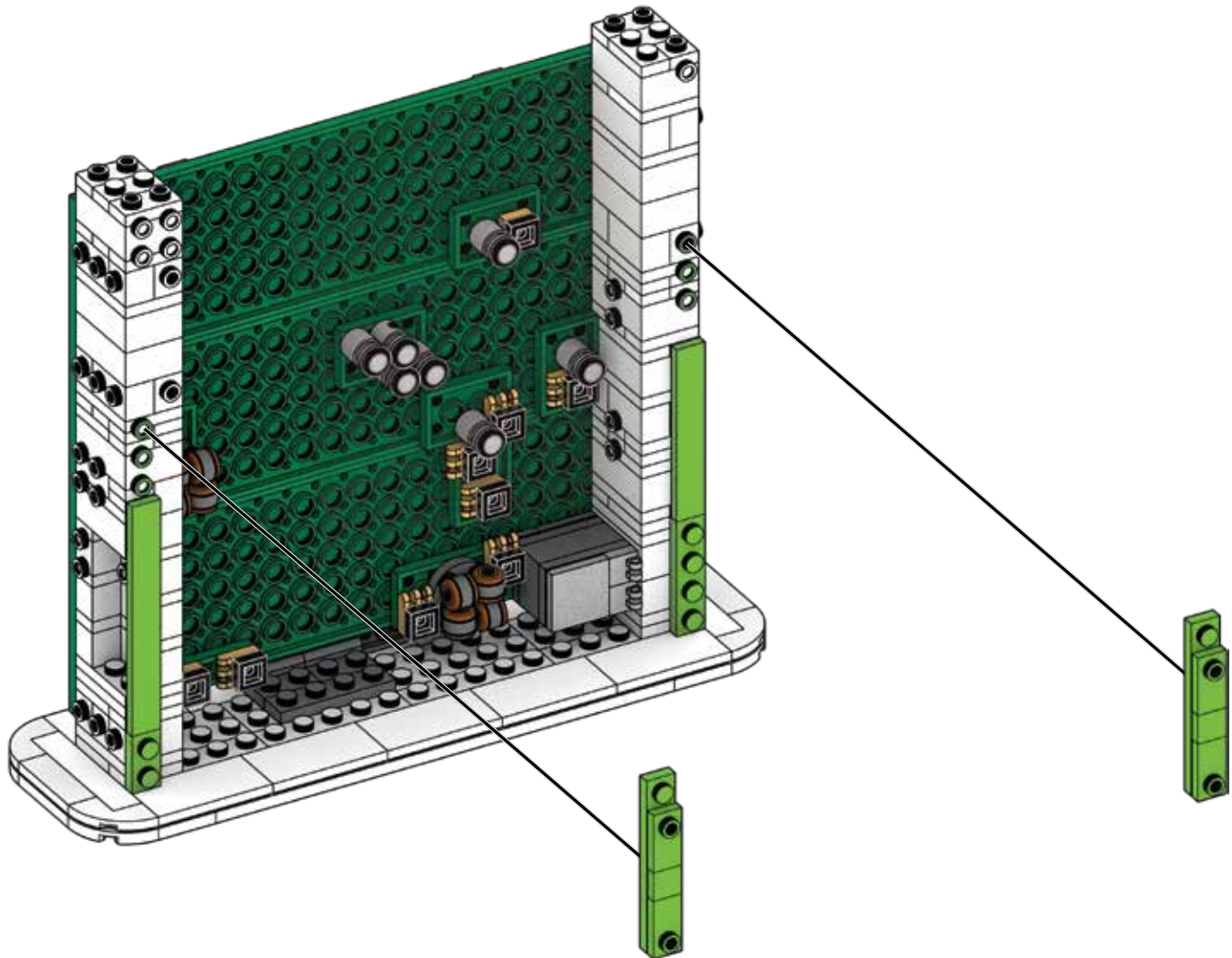
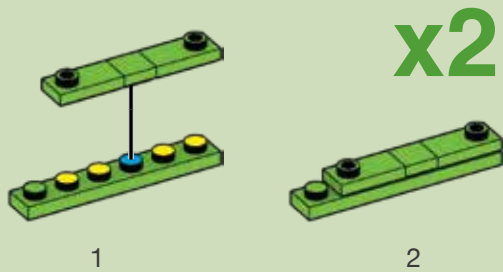

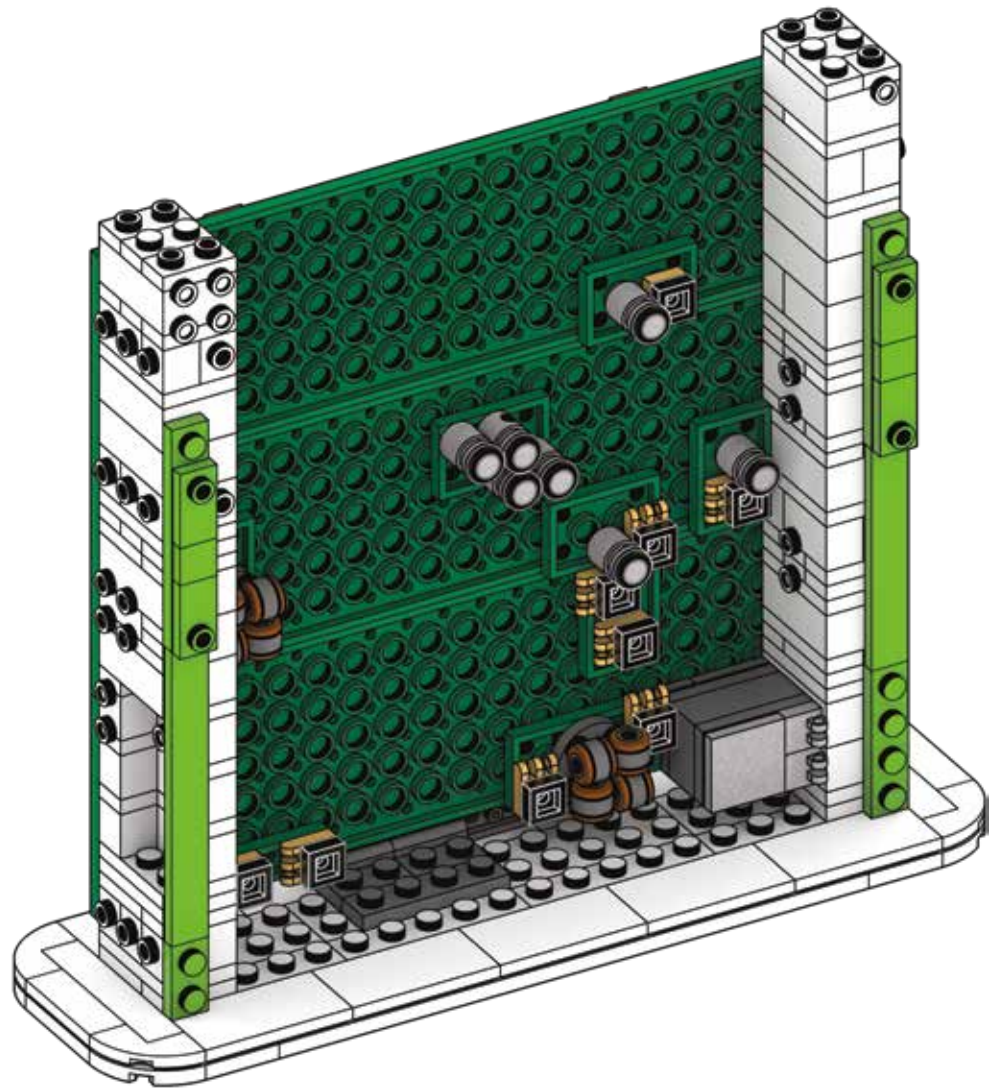

142

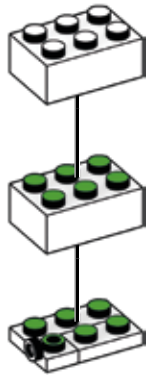
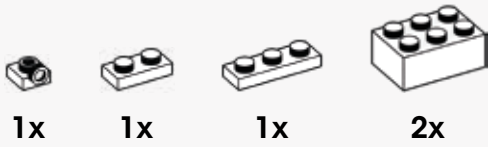

143

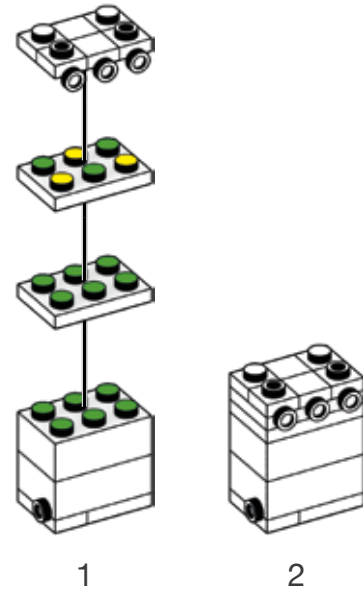
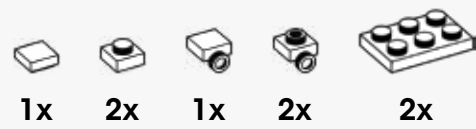

144

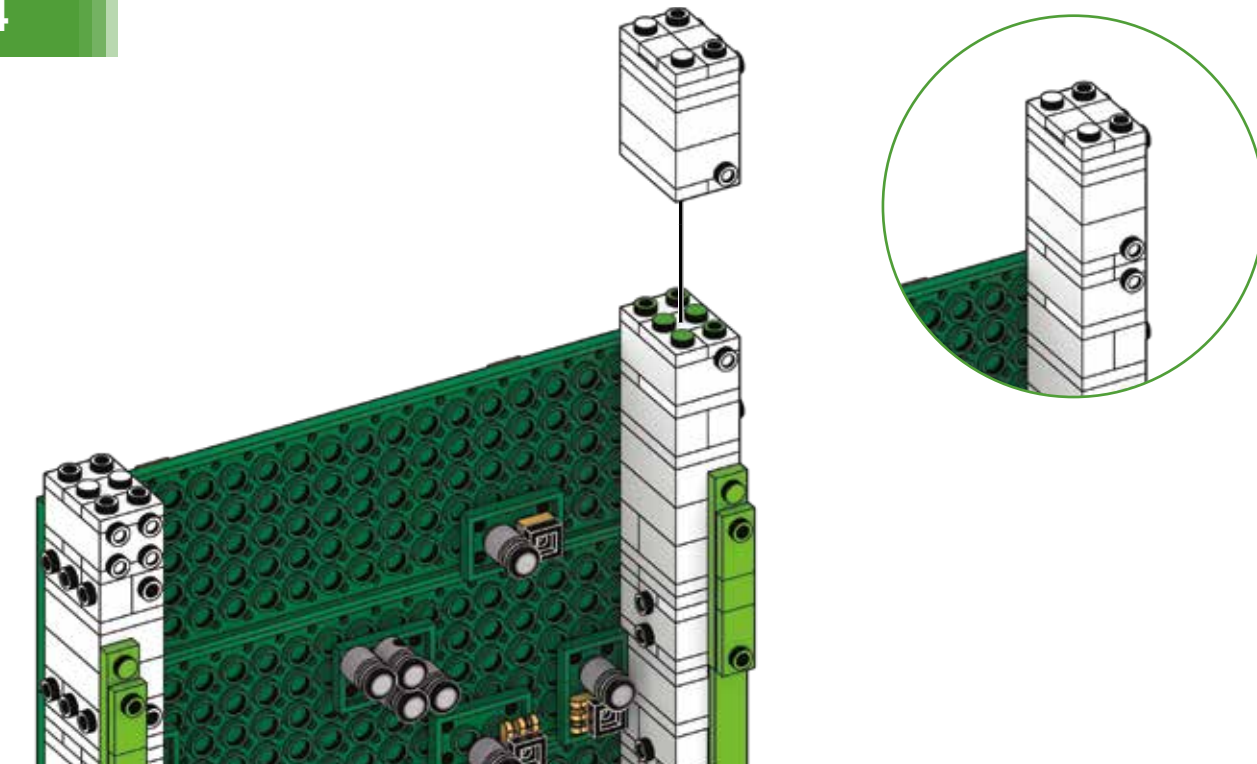

145

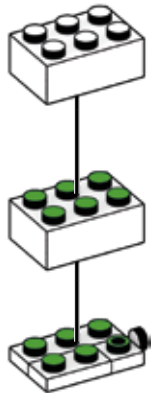
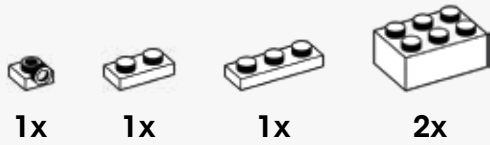

146

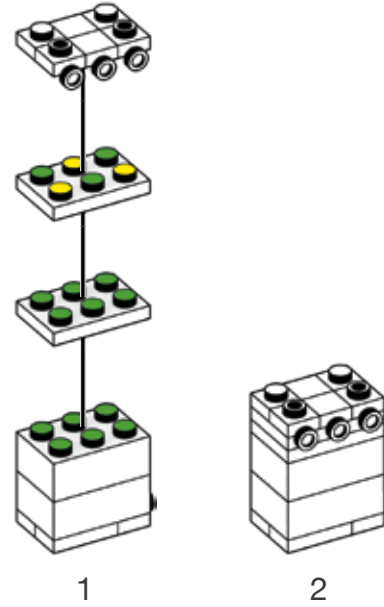
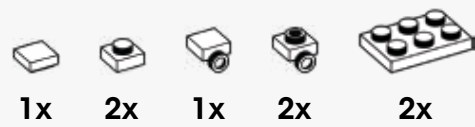

147

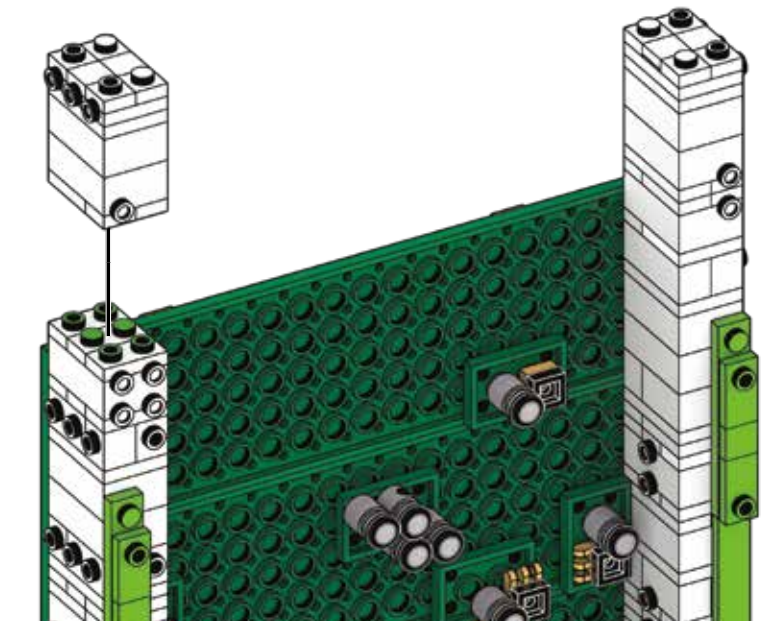

148



4x

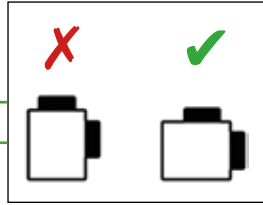

1

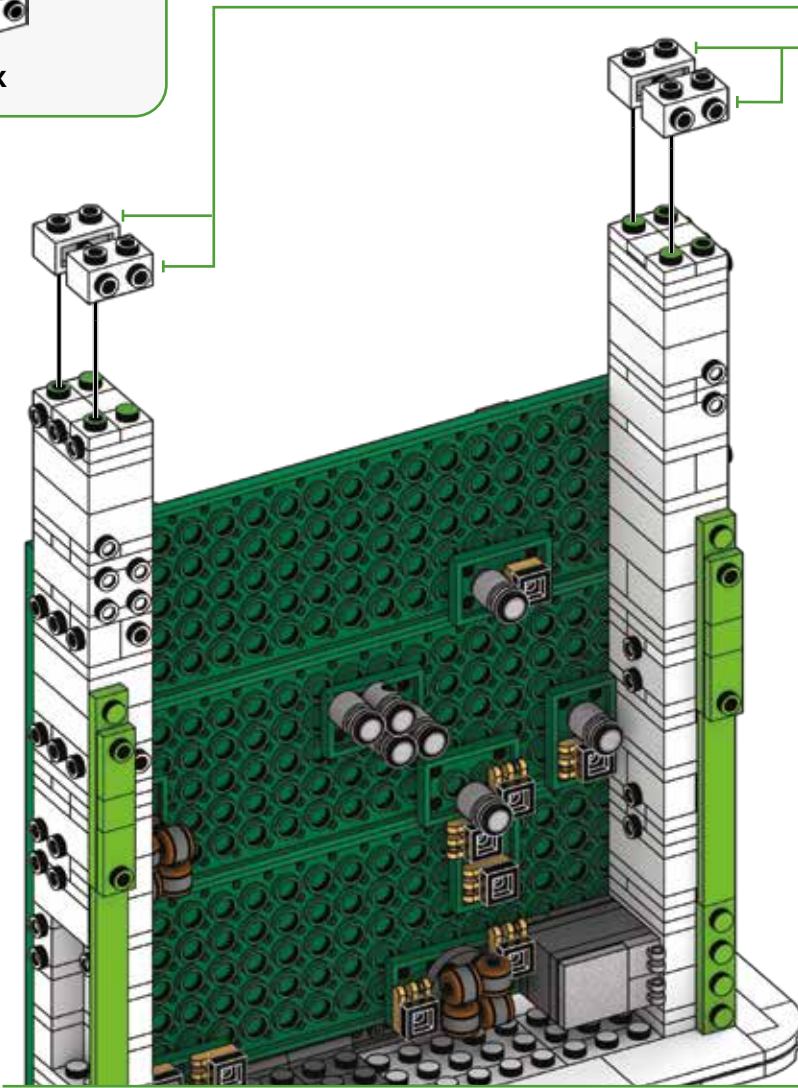

2

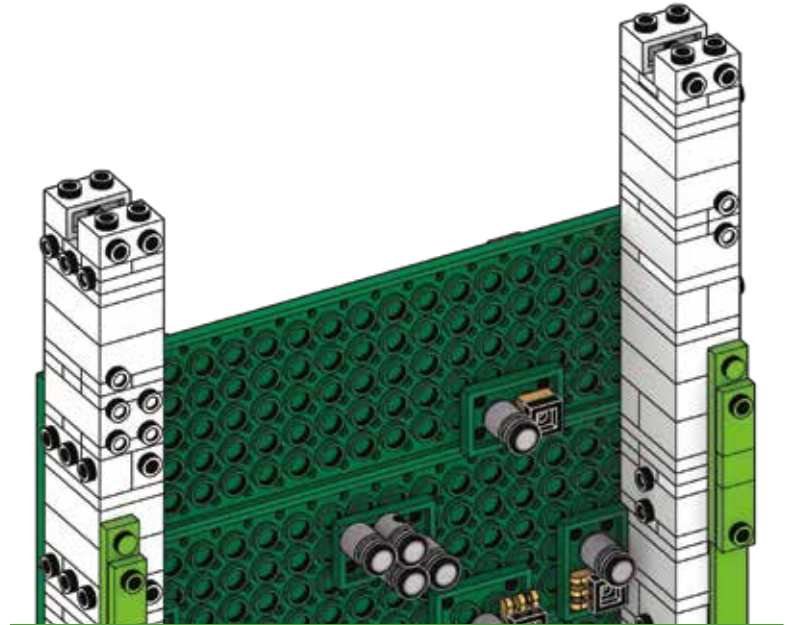



149



3x



3x

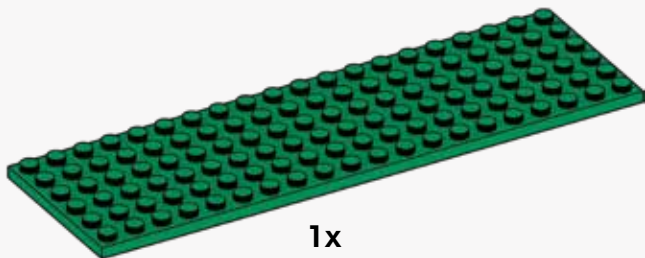

1x

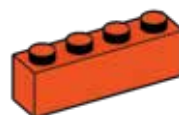

Place temporary pieces.
Placer les pièces temporaires.

Colocar las piezas provisionales.
Colocar as peças provisórias.
Posizionare i pezzi provvisori.
Die vorübergehend benötigten Teile platzieren.
Umieść tymczasowe elementy.
Plaats tijdelijke delen.
Поместите временные детали.
Placer midlertidige stykker.
Placera temporära delar.
Plasser midlertidige deler.
Aseta väliaikaiset osat.
Τοποθετήστε το προσωρινό κομμάτι.
Geçici parçaları yerleştirin.
Umístěte dočasné díly.
Vložte dočasné kusy.
Helyezze el az ideiglenes darabokat.
暫定ピースを配置してください。
ضع القطع المؤقت.
放置临时件

x3

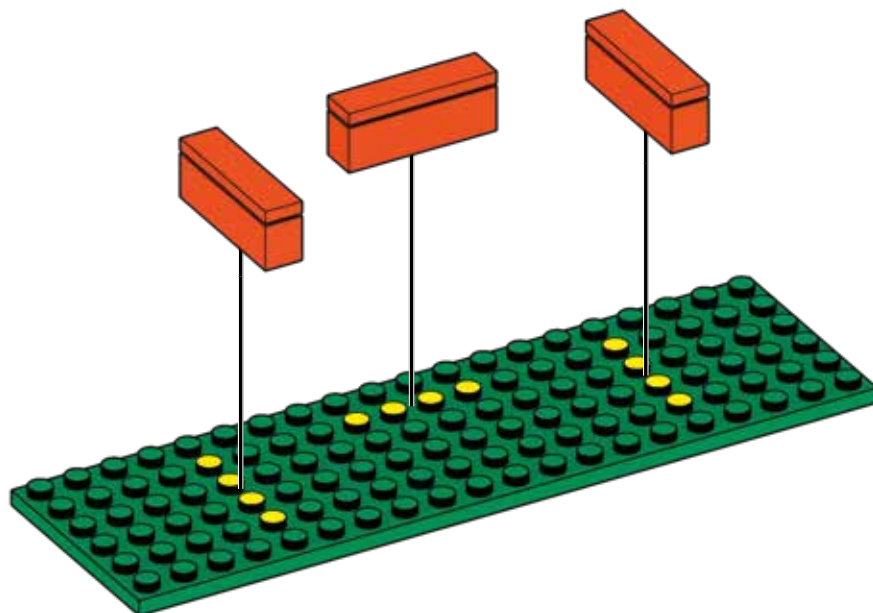
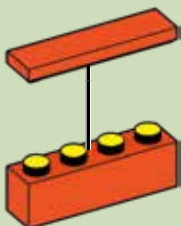

150



4x



1x

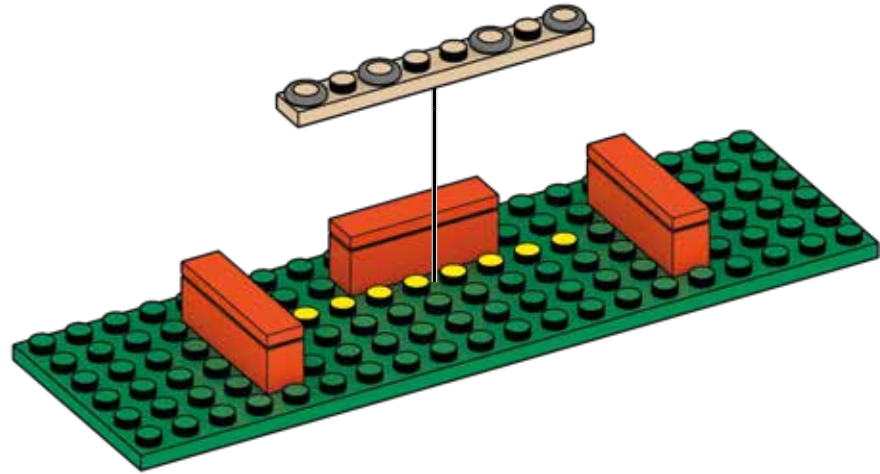
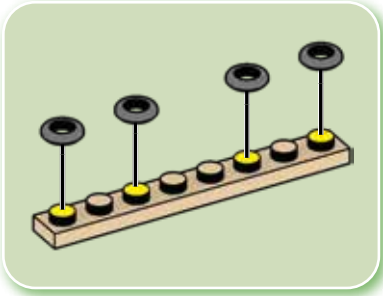

151



4x

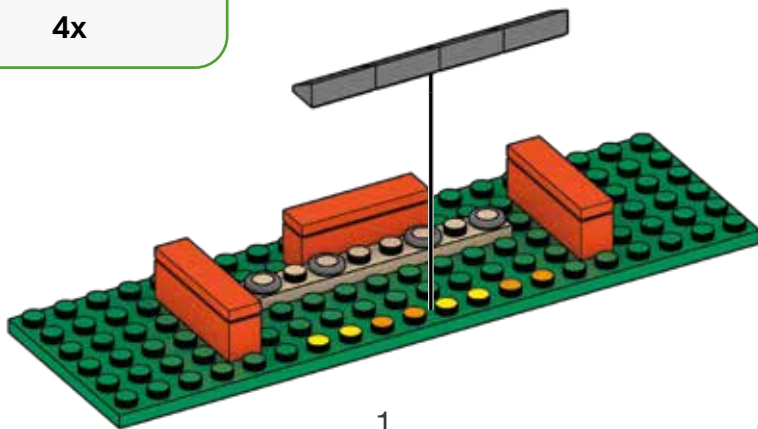

1

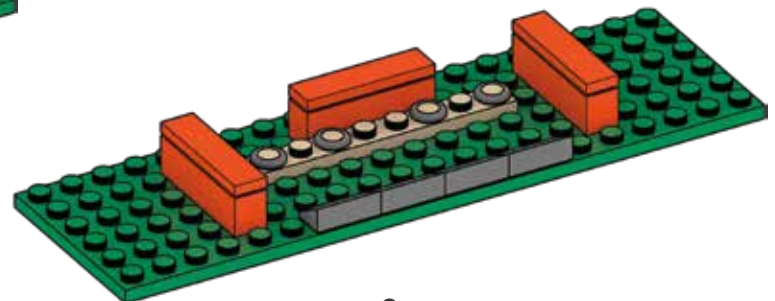

2

152



1x

2x



1x



153



1x

1x

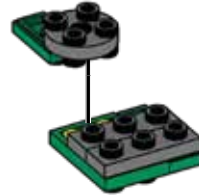

154

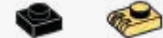

1x

1x

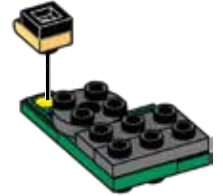

155



8x

4x

x4



156



1x

1x

1x

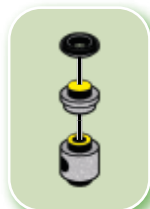

157



1x

1x

1x



158



1x



1x



1x



1x



1

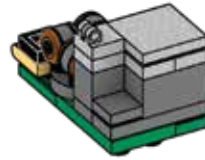

2

159

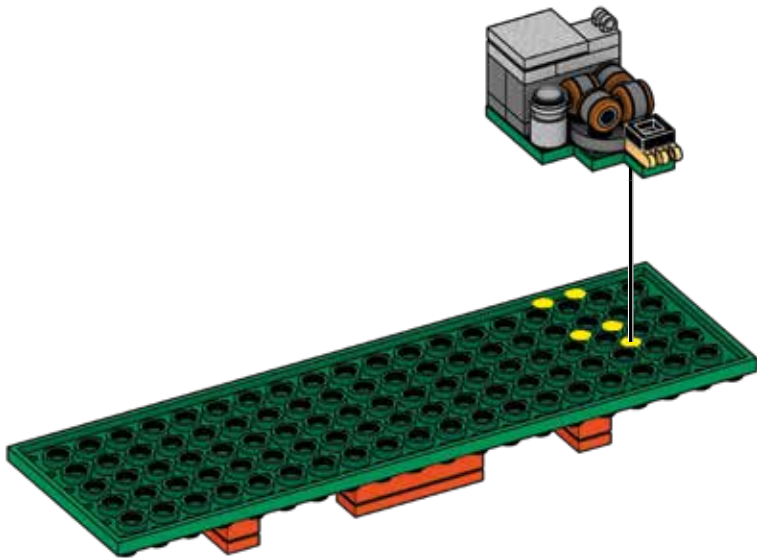

1

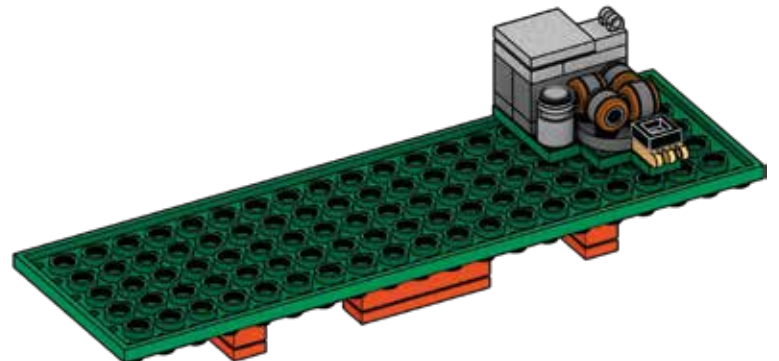

2

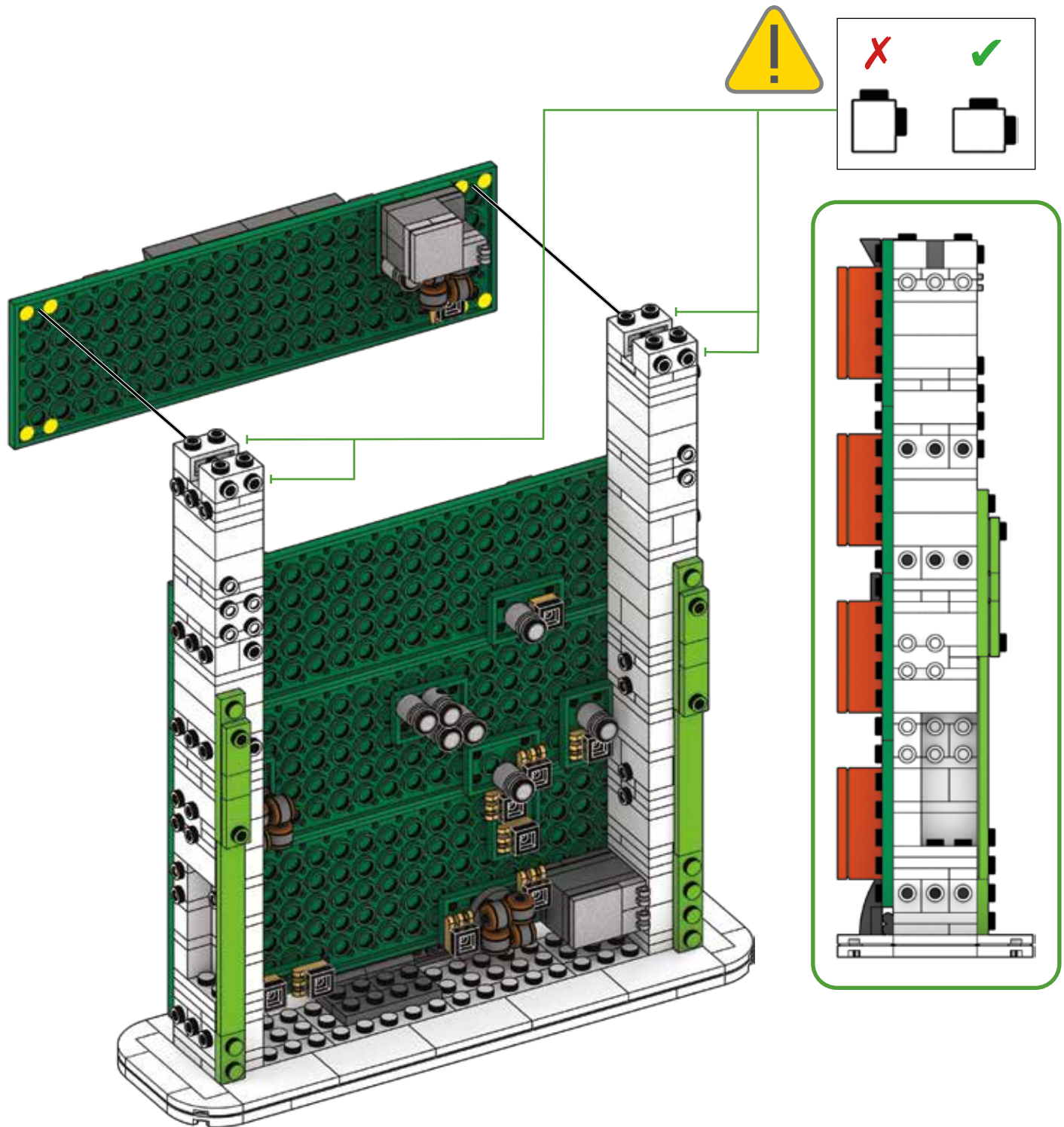

161



2x



2x

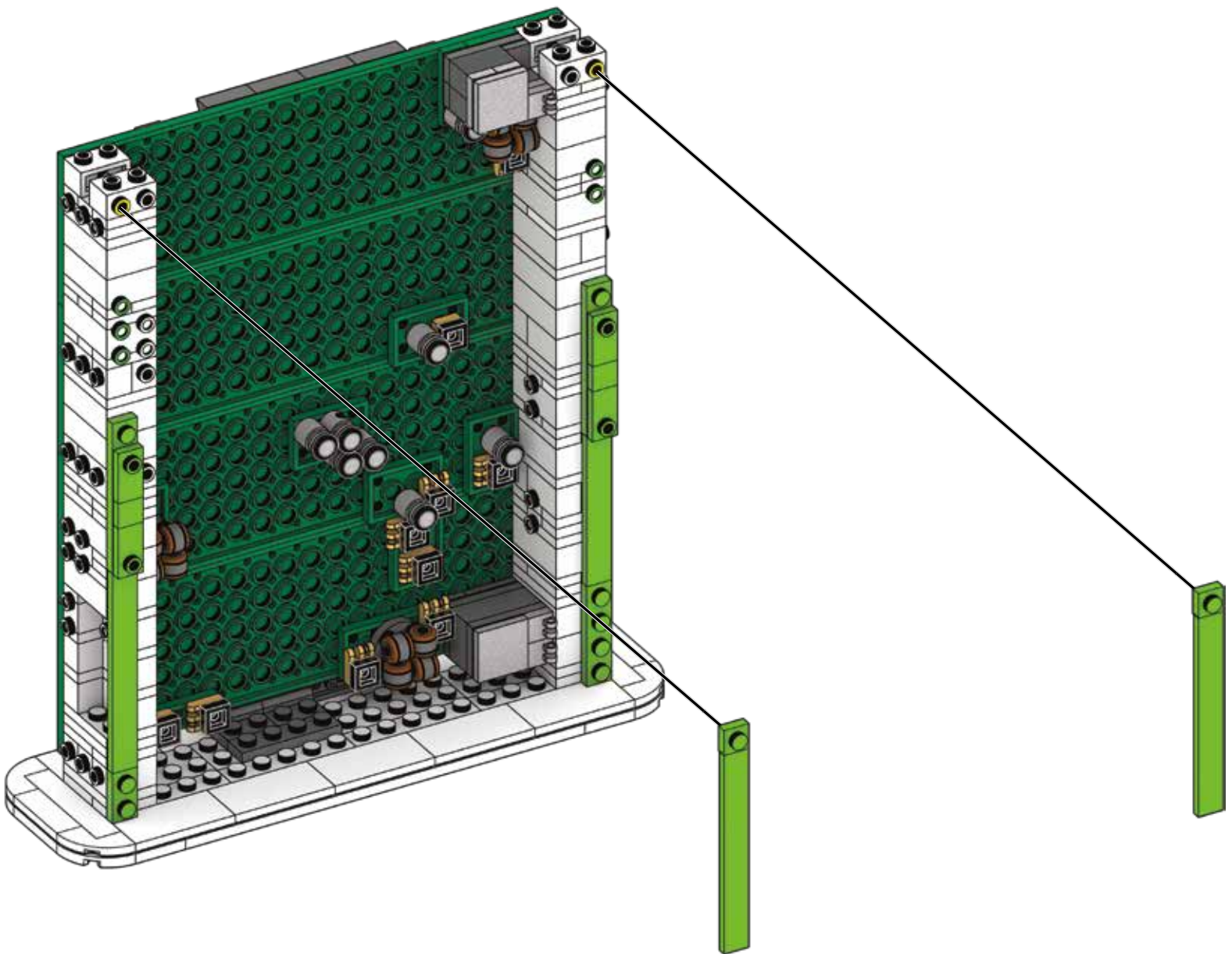

162



2x

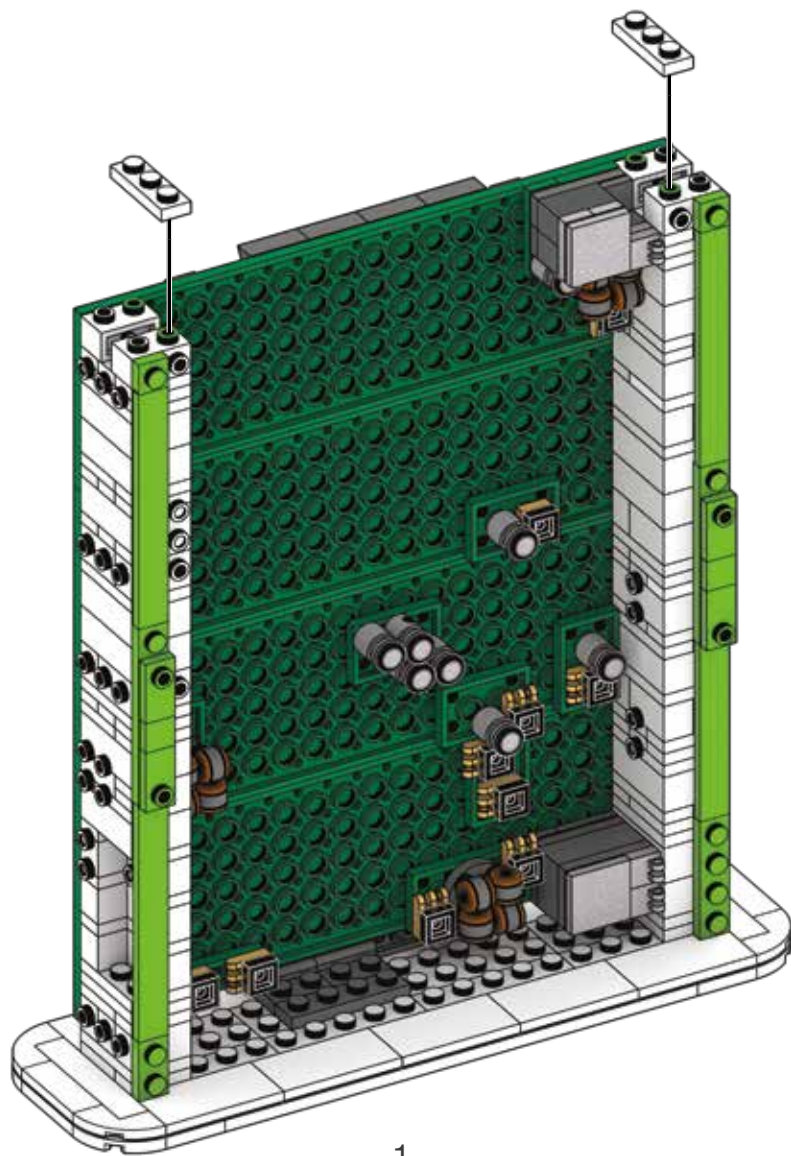

1

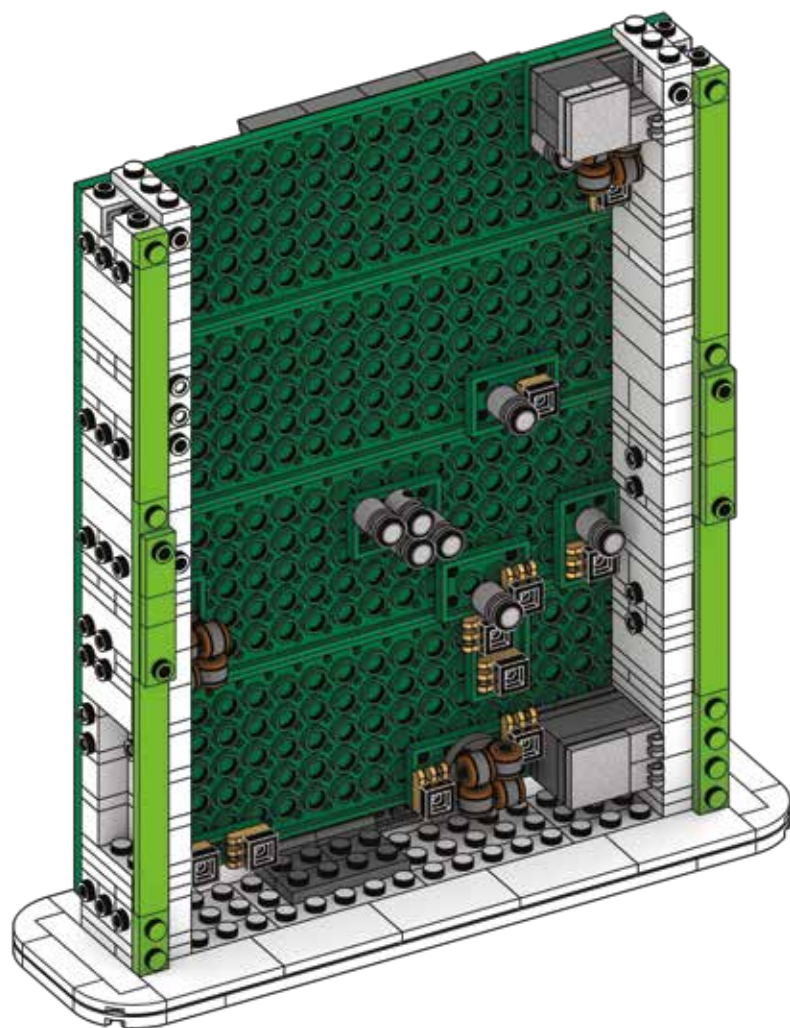

2

165



1x



2x

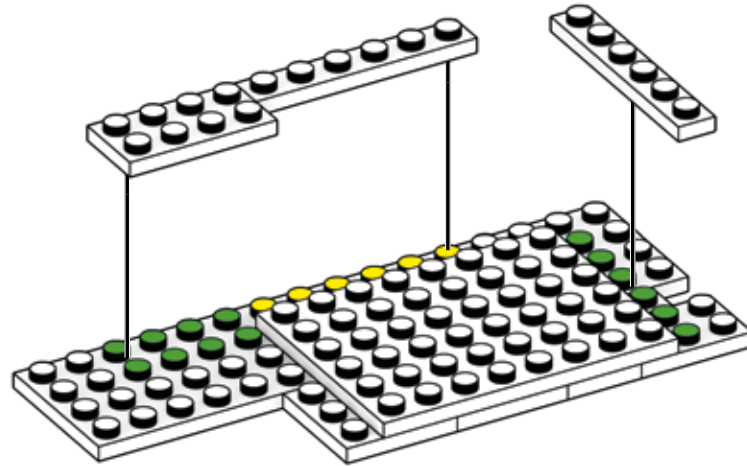

166



2x



1x

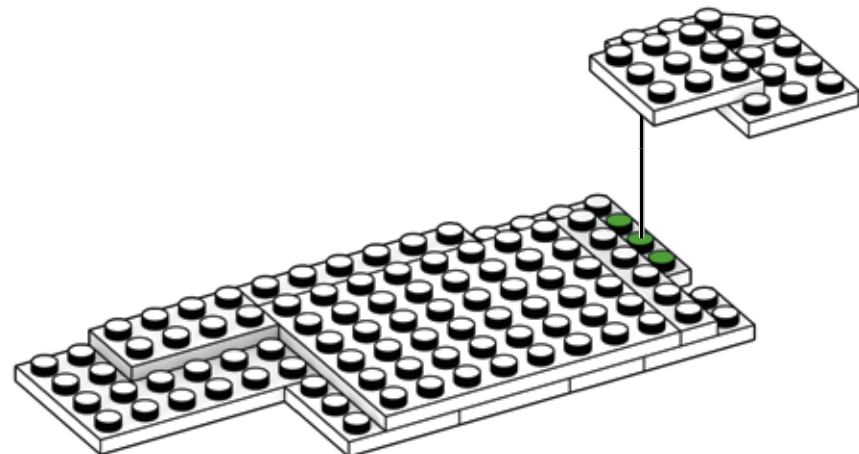
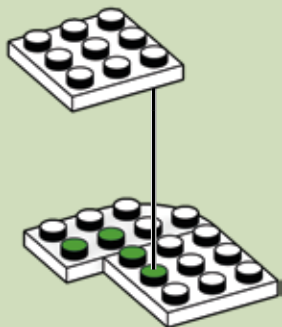

167



1x

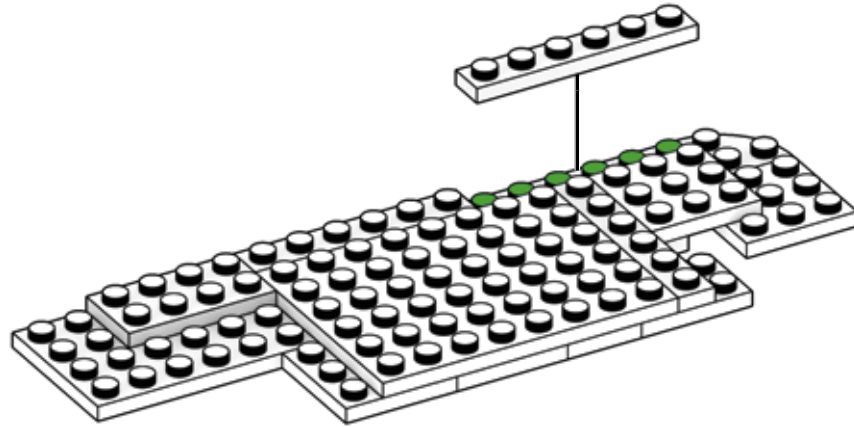

168



1x



1x

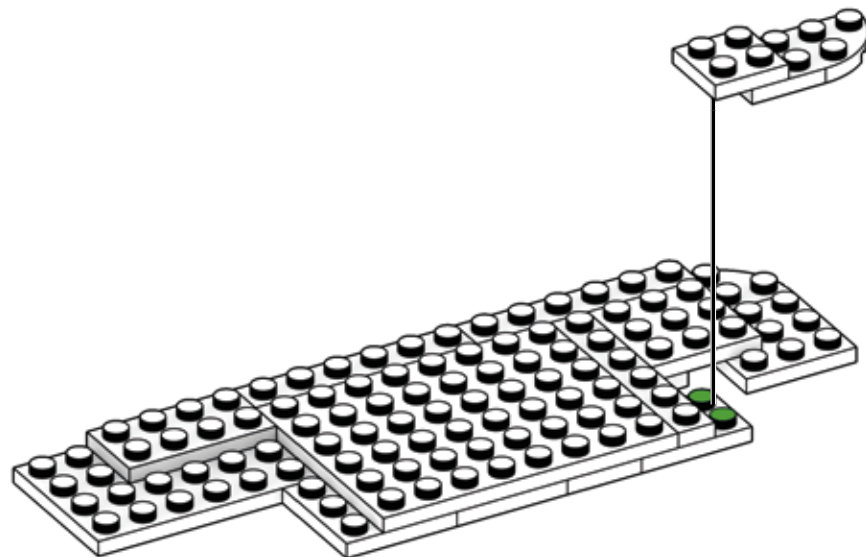
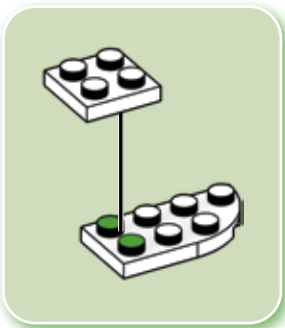

169



2x

2x

1x

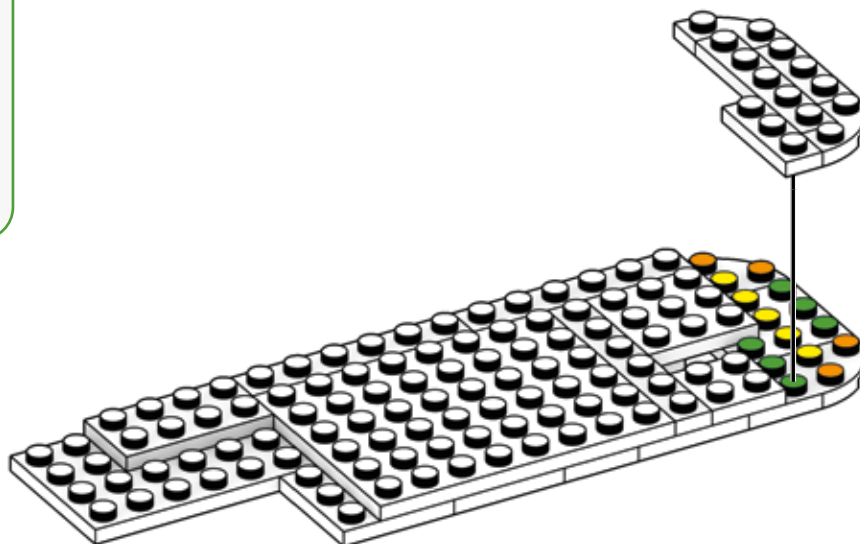

170



1x

1x

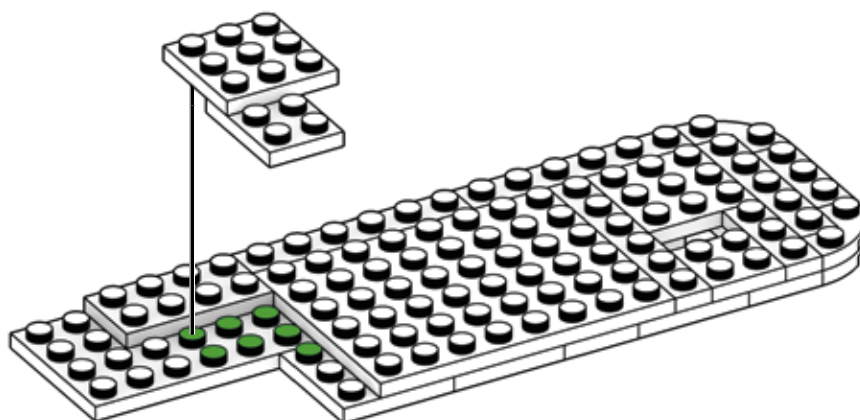
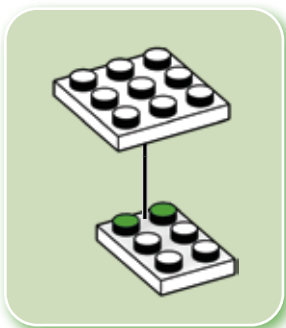

171



1x



1x

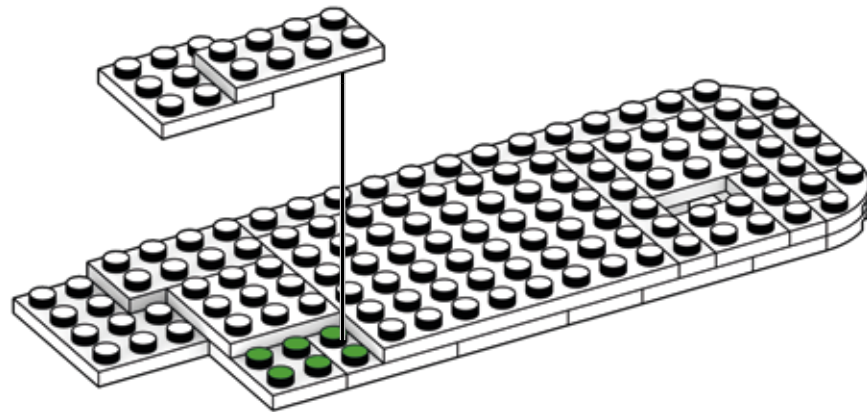
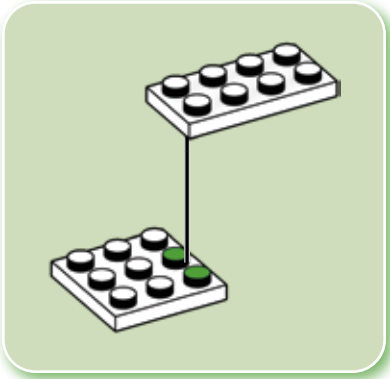

172



1x

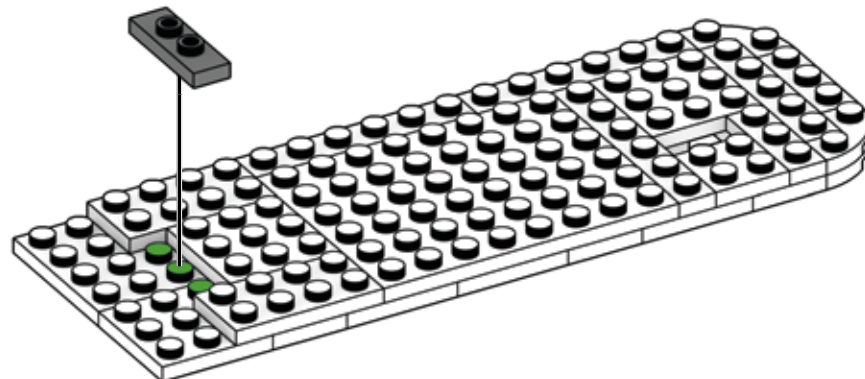

173



1x



1x



1x

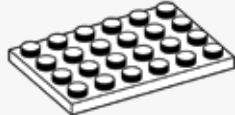

1x

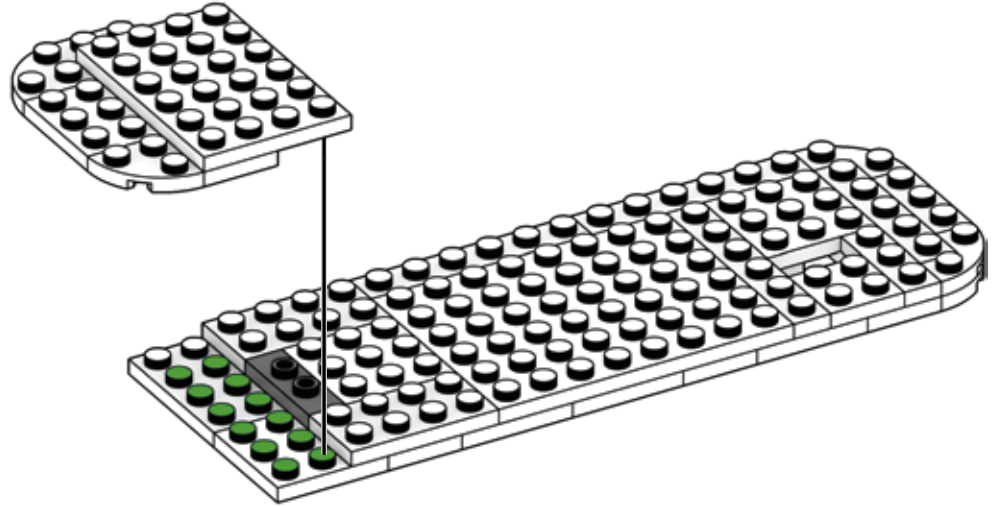
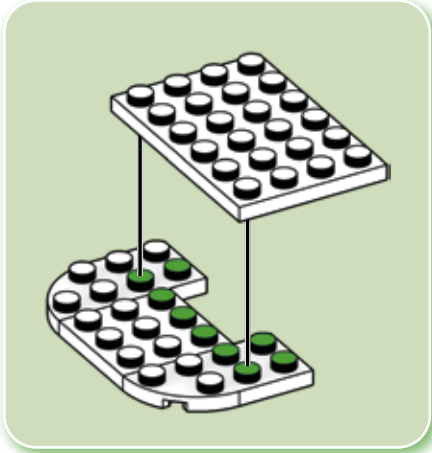

174



2x



1x



1x



1x

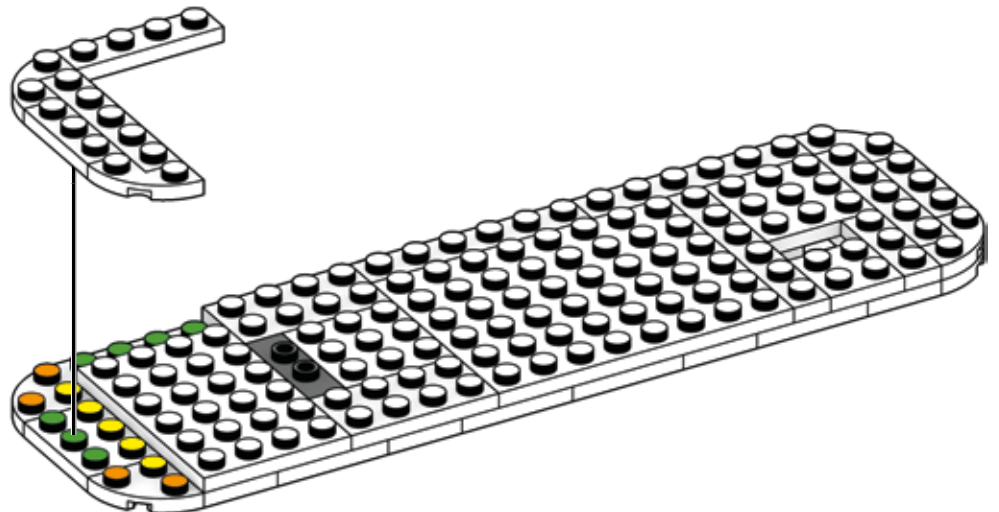

175

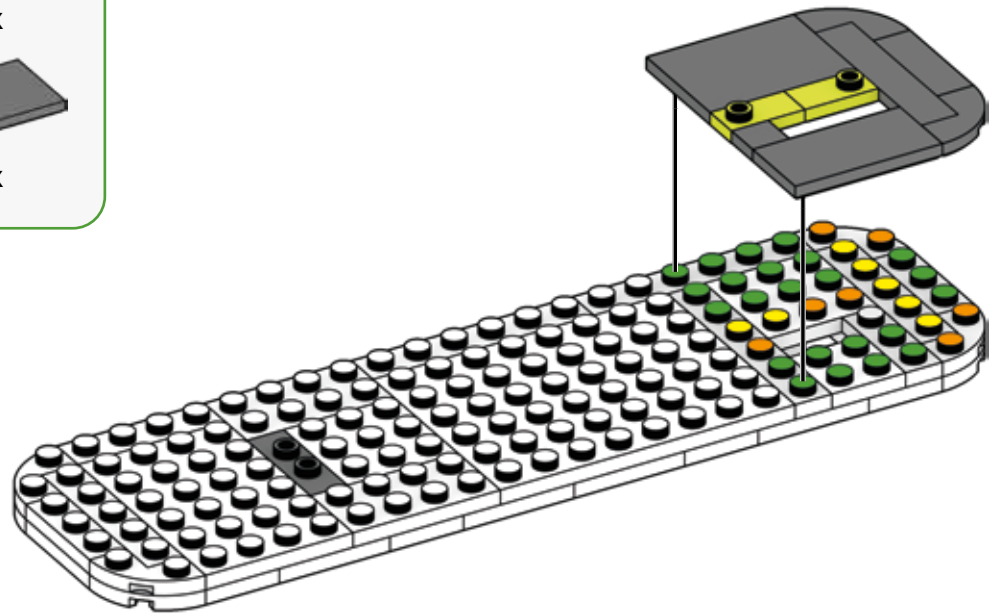
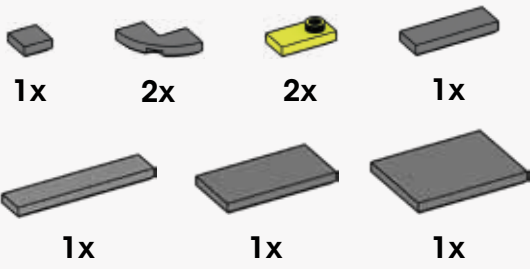

176

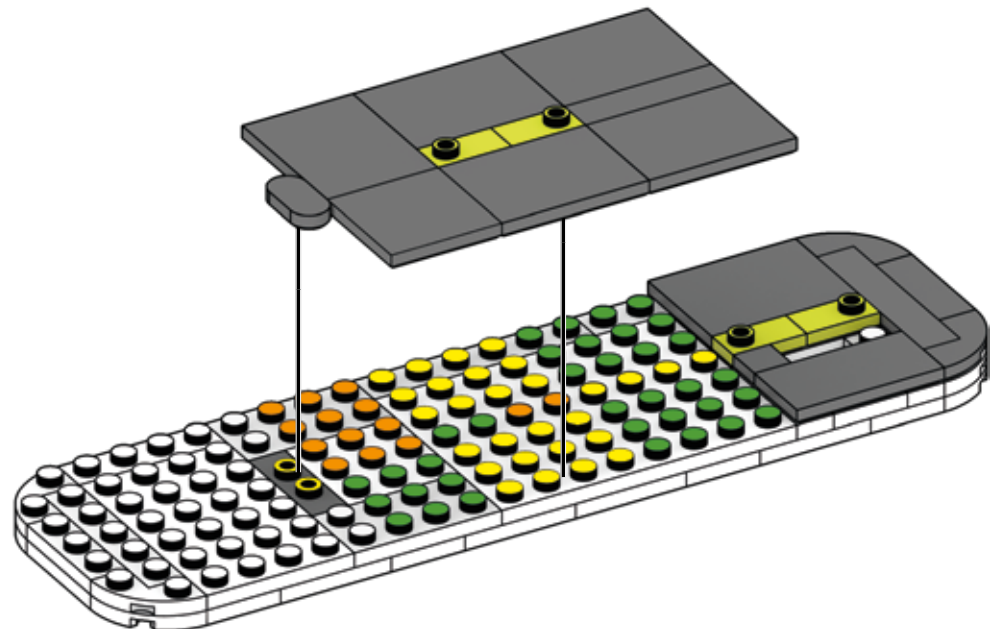
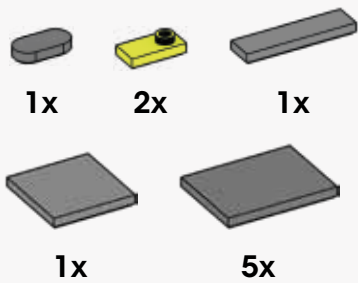

177

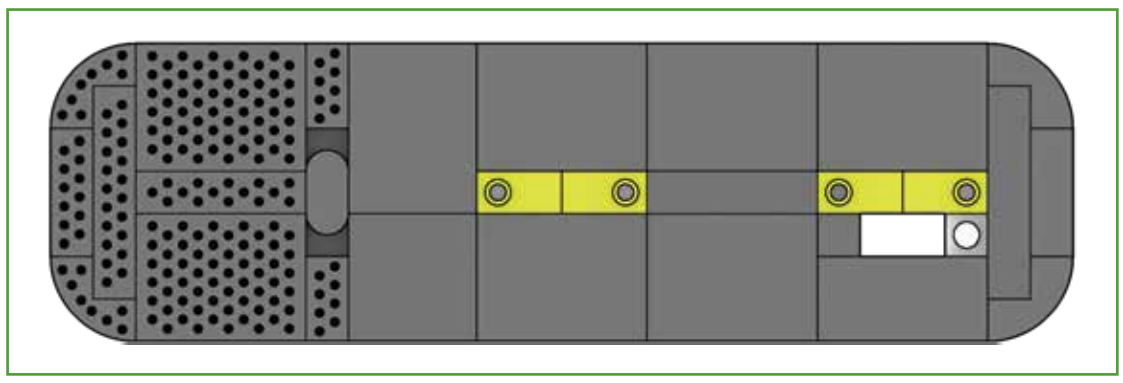
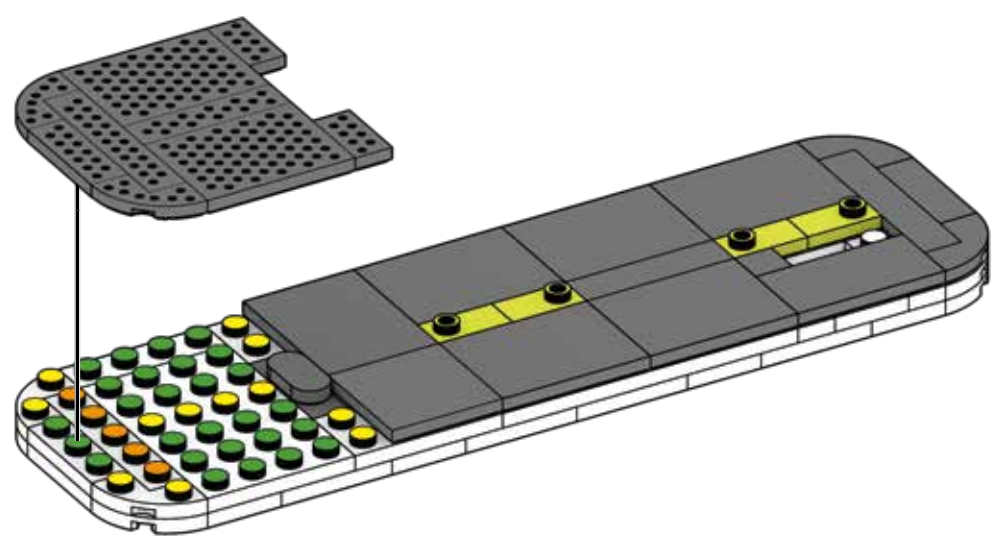
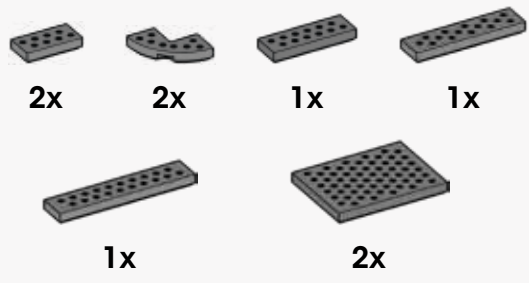

178



1x



1x



1x

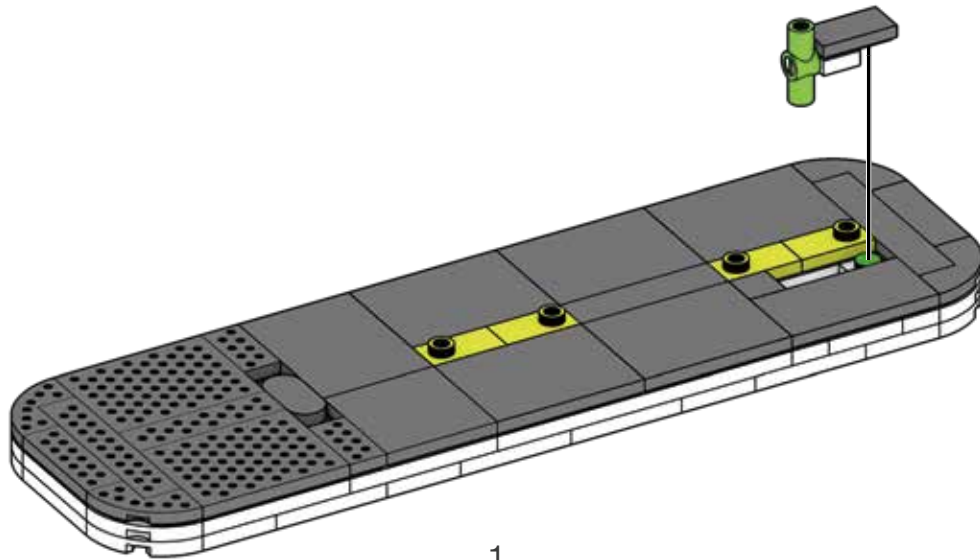
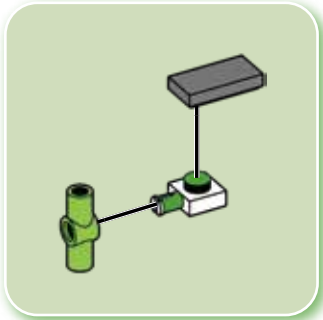

1

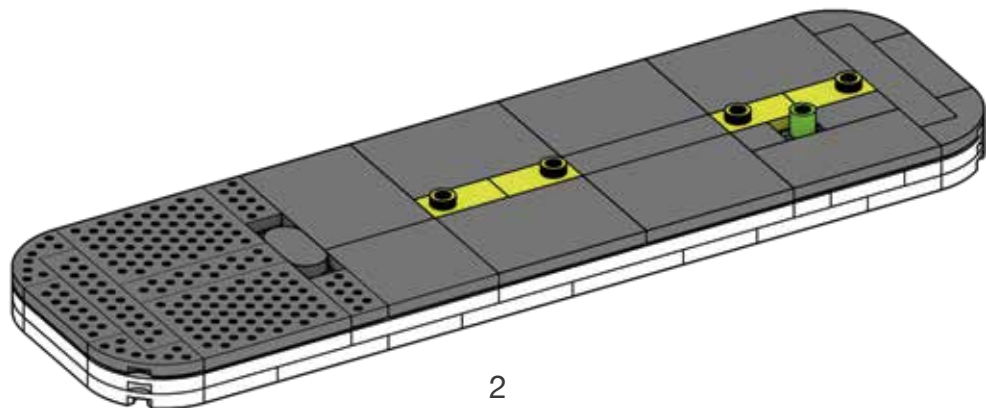

2

179



1x



1x

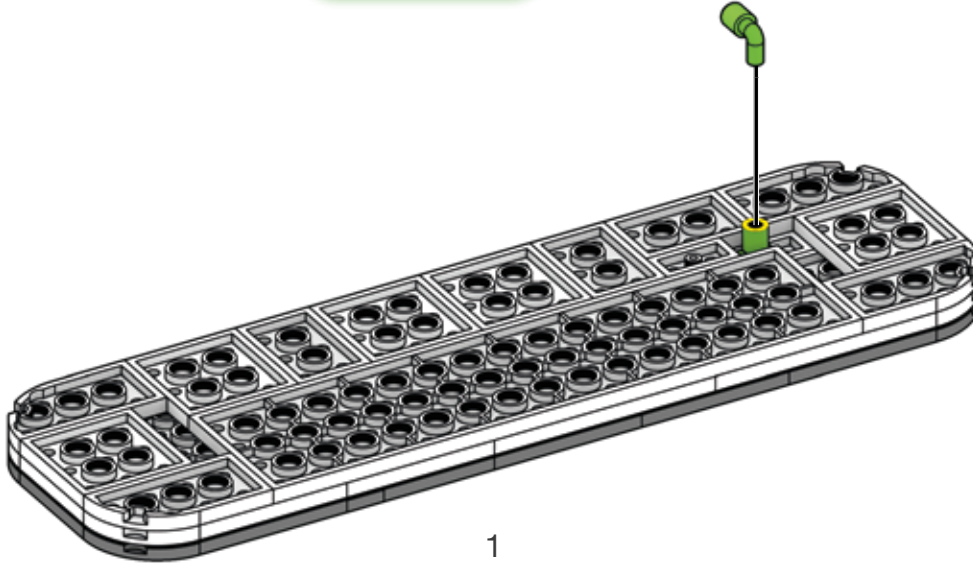
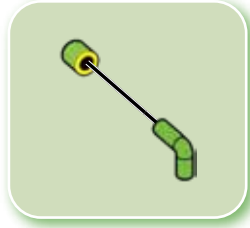

1

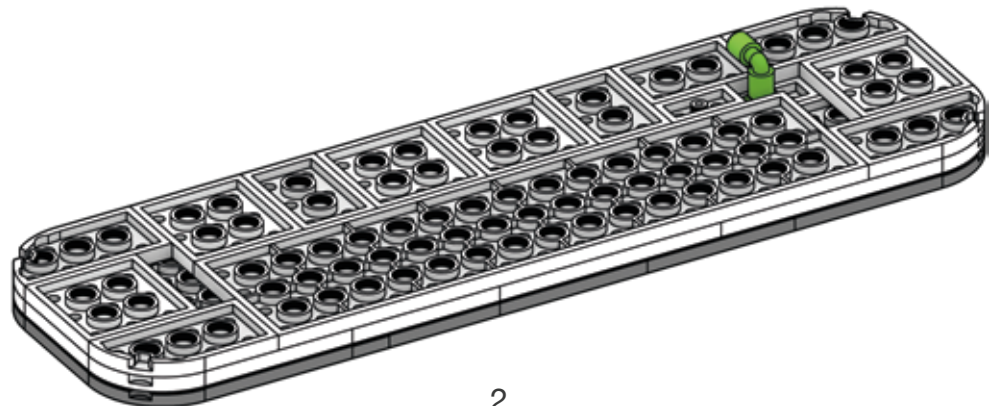

2

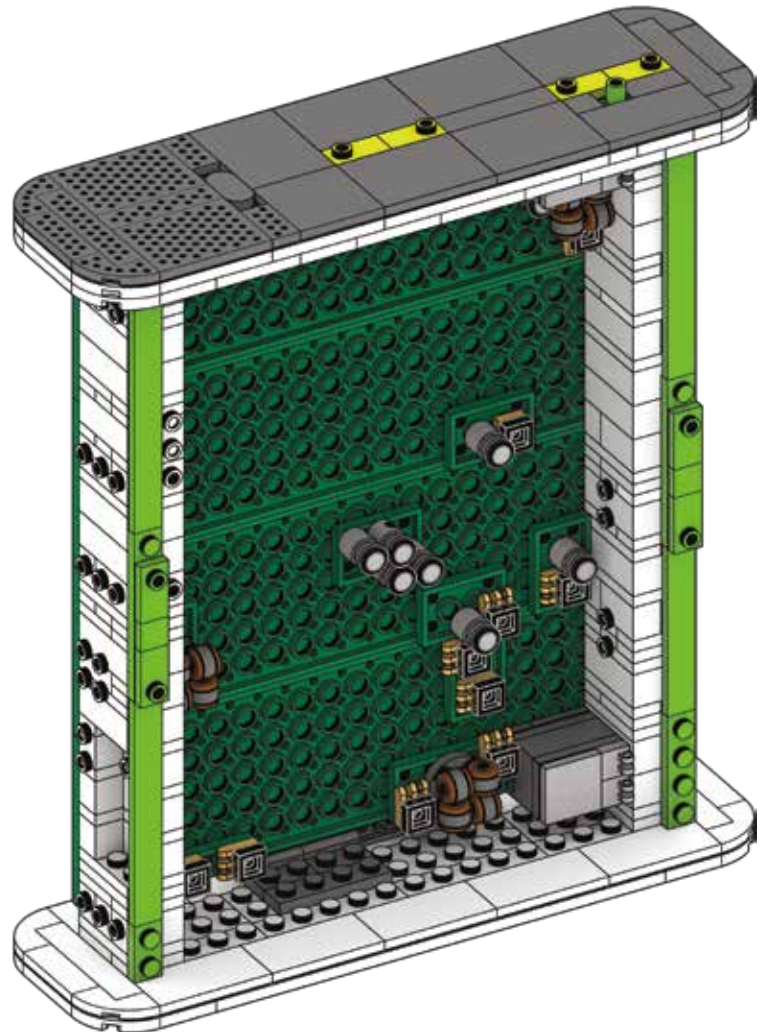
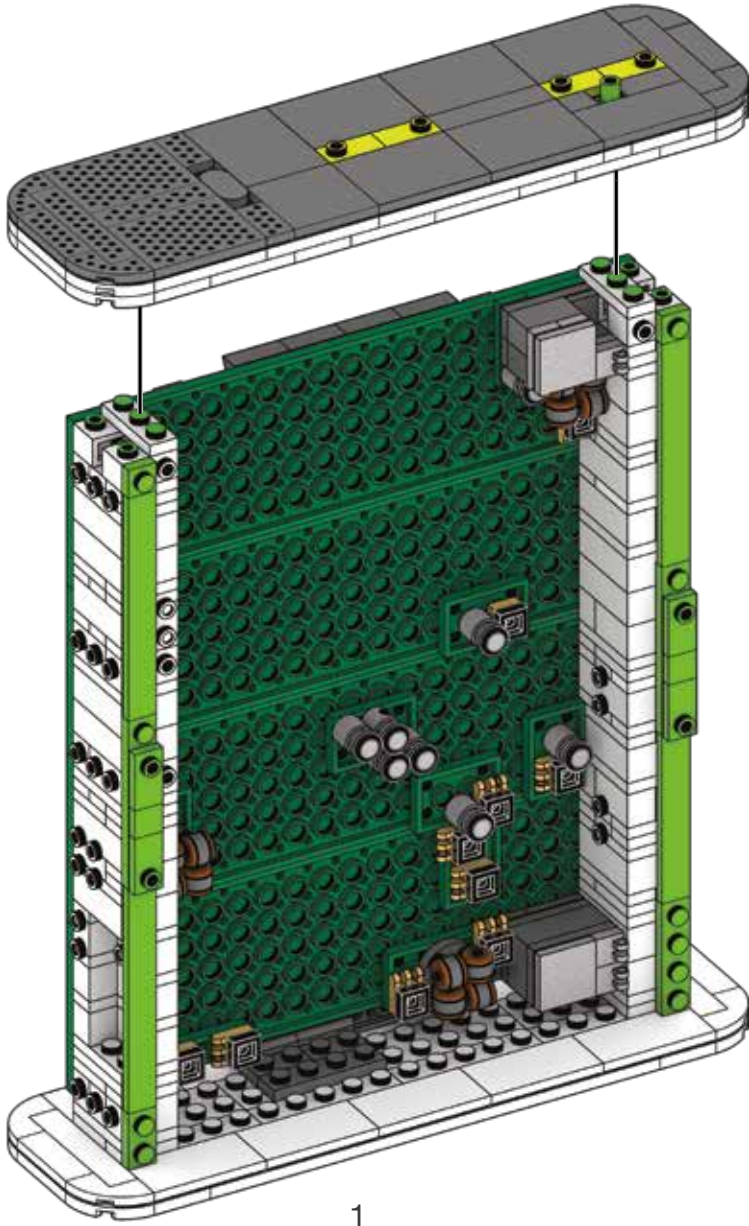

181



1x



7x

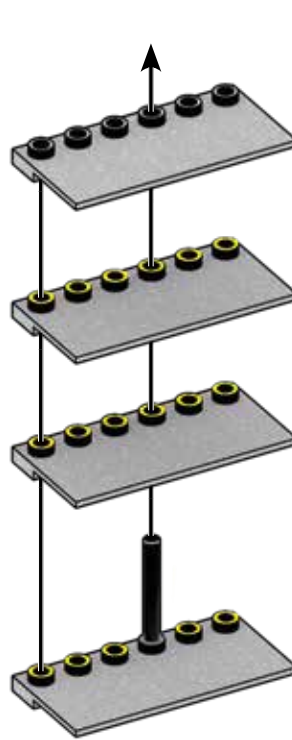
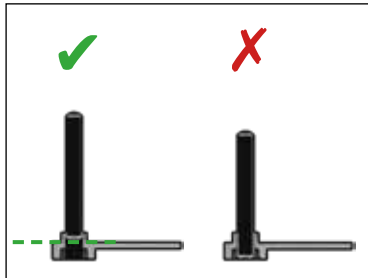
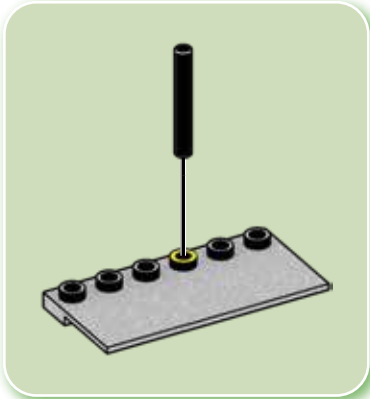

1

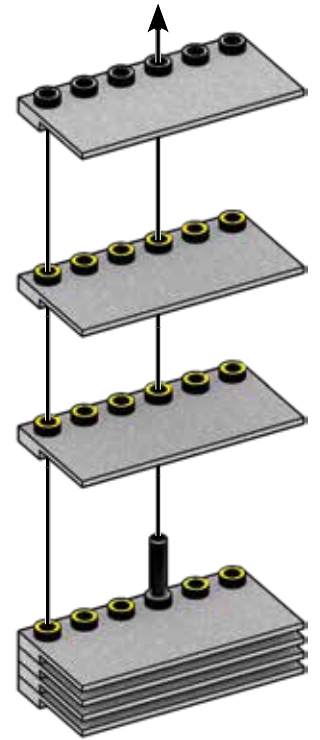

2

182



1x



1x



1x

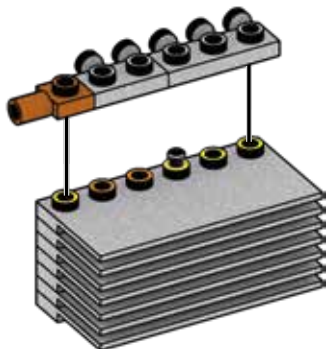

183

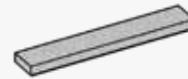

1x

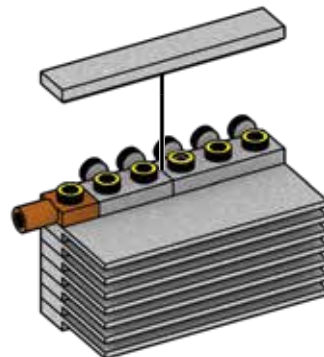

184



2x



2x

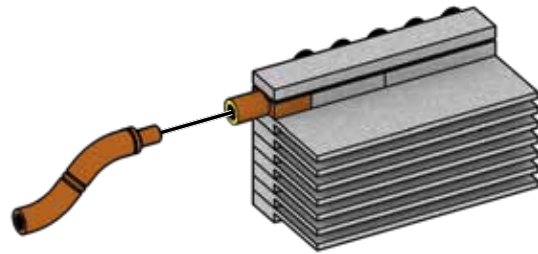
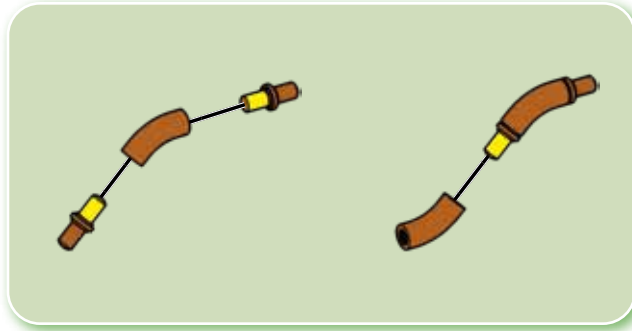

1

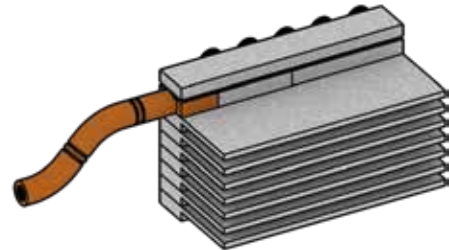

2

185

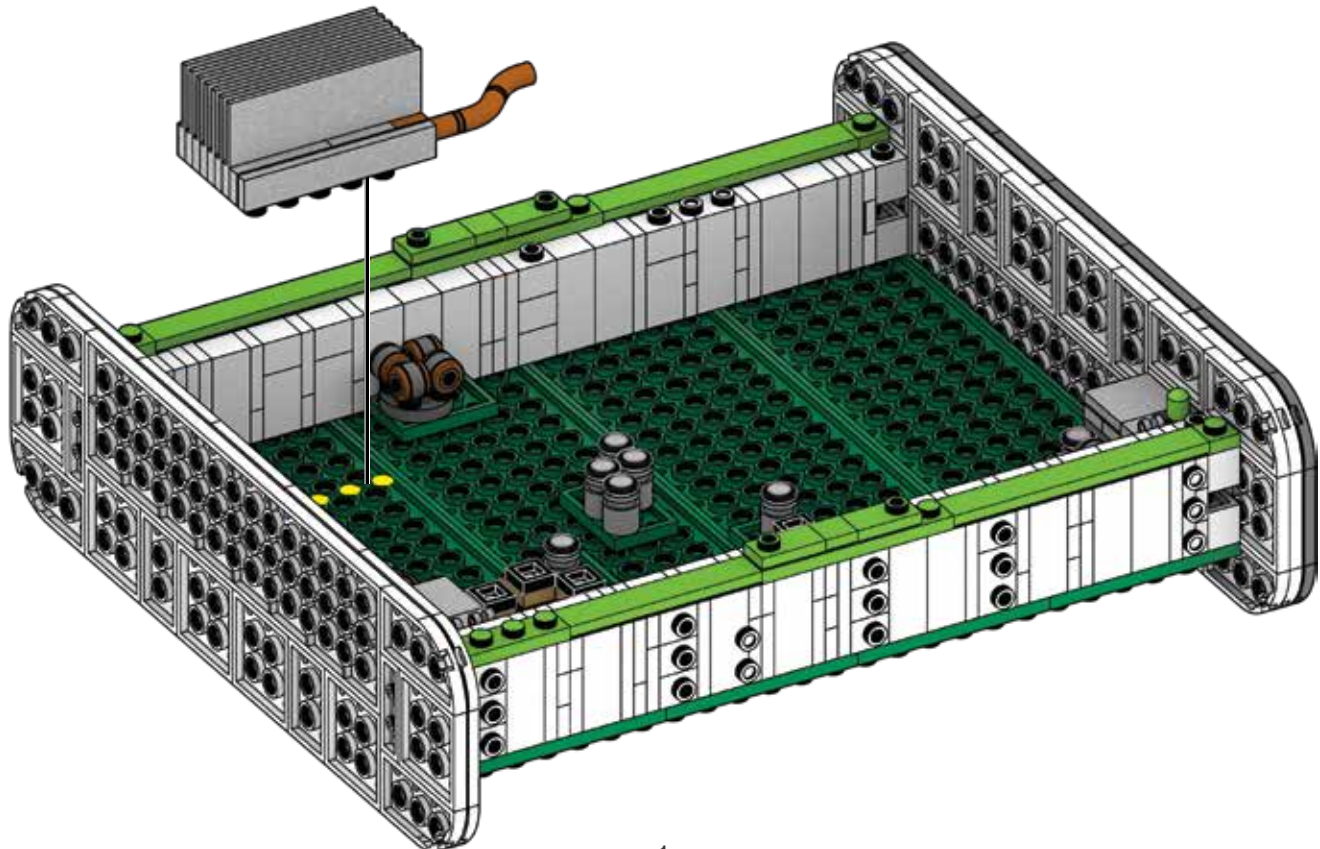

1

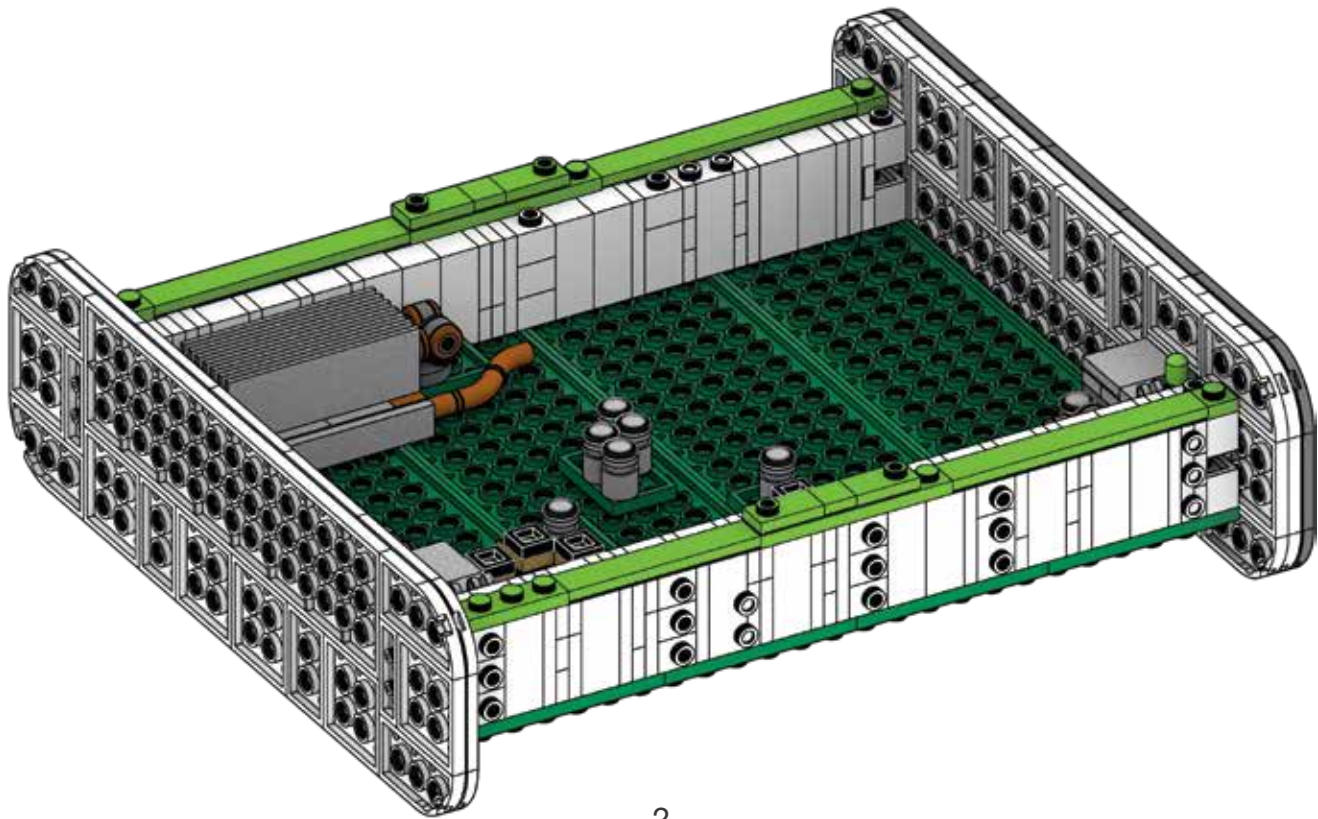

2

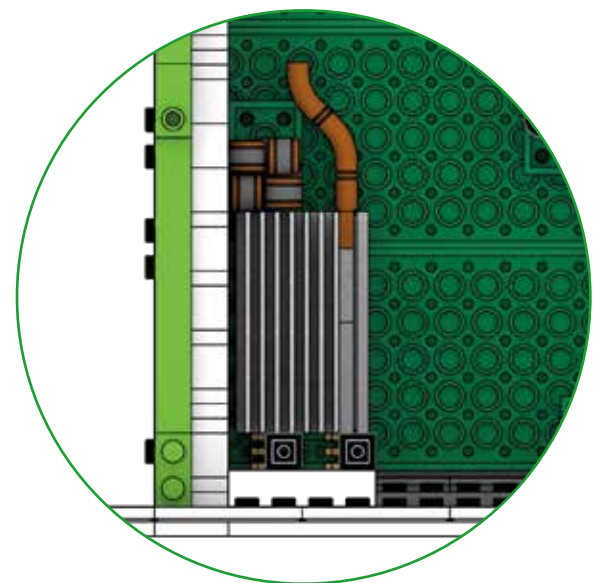



186

1x 1x

187

2x 1x

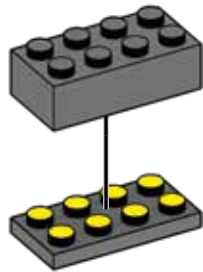

188

2x 1x 1x

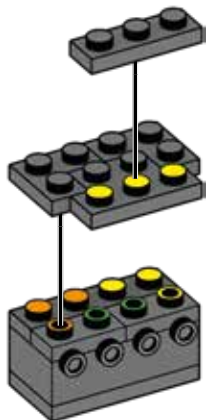

189

1x 1x
1x

5

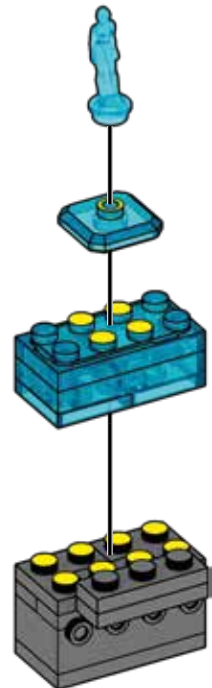
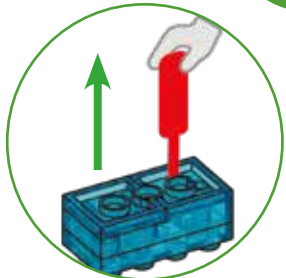

190

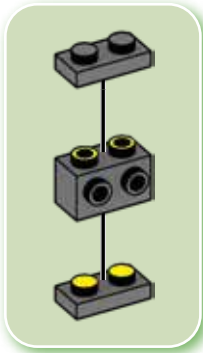

1

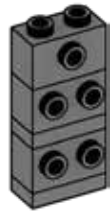

2

191



192

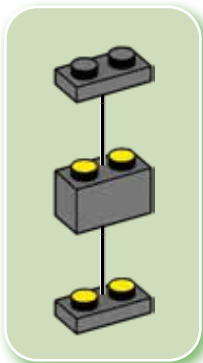
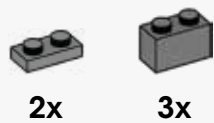

1

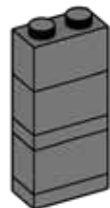

2

193

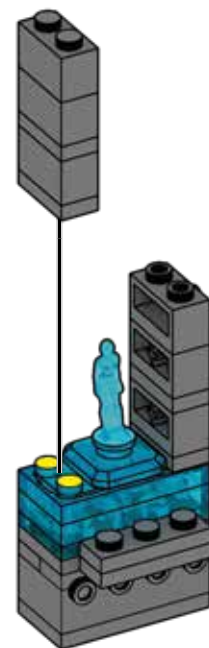

194

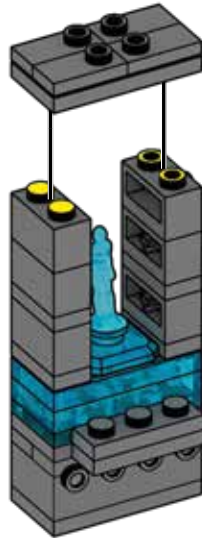
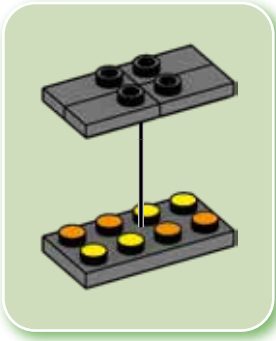

195

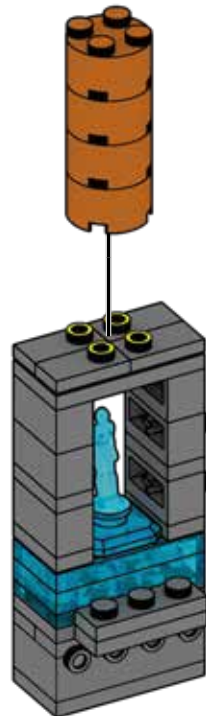
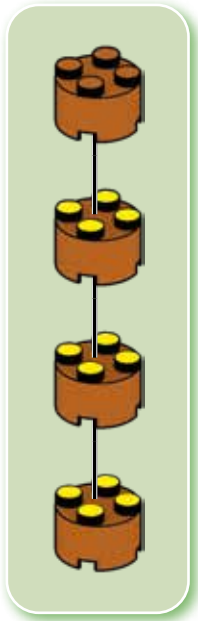

196



1x

1x

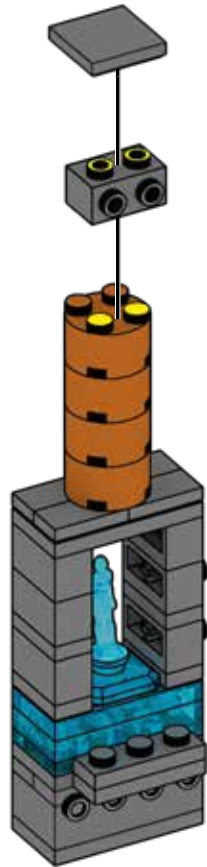

1

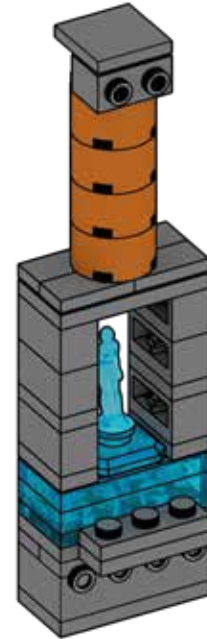
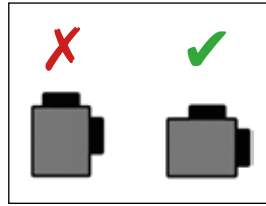

2

197



2x

1x

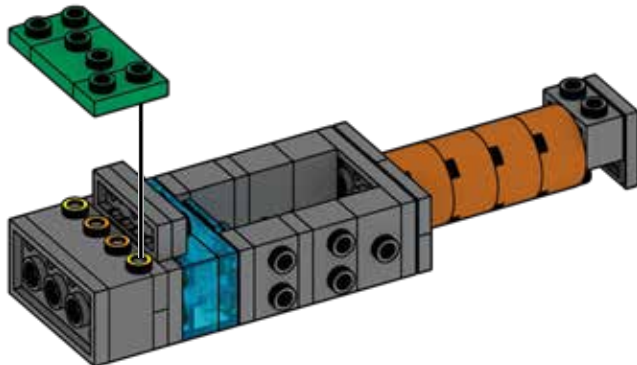

198



2x

2x

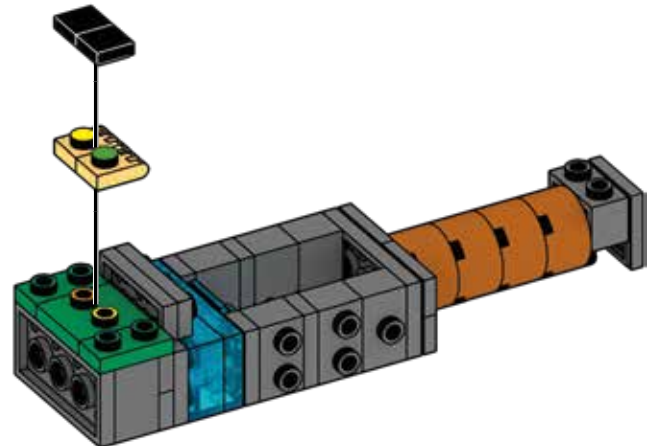

199



8x



4x

x4

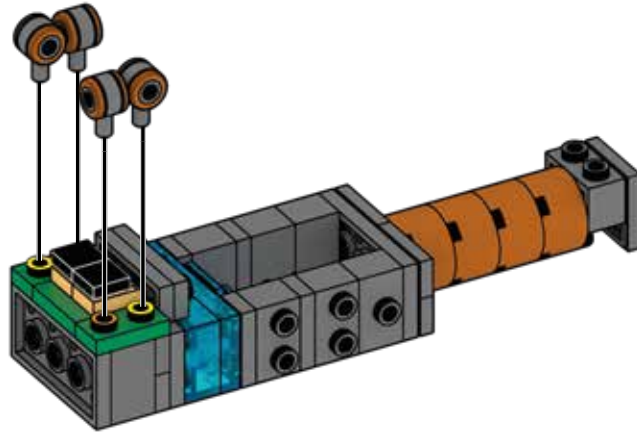

200



1x



1x



1



2

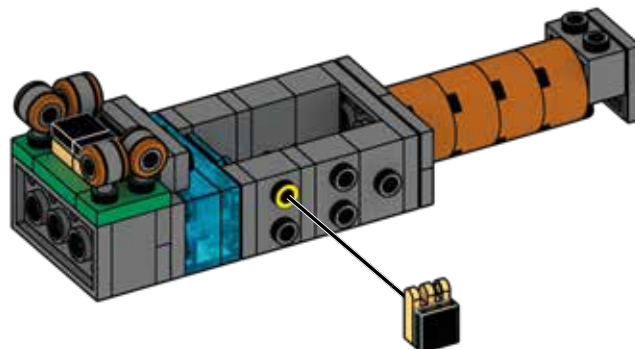

201



2x



1x



1x



1



2

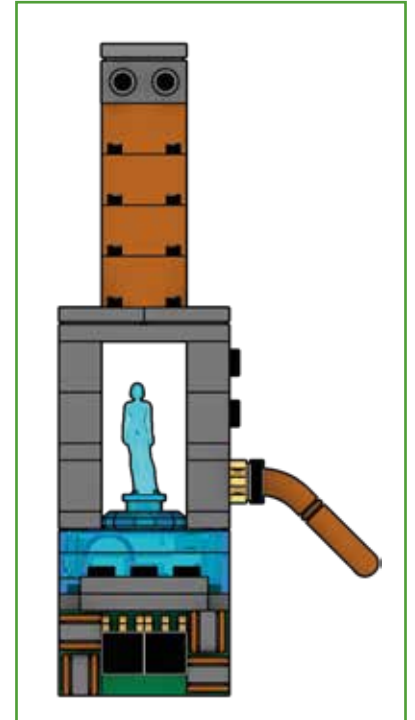
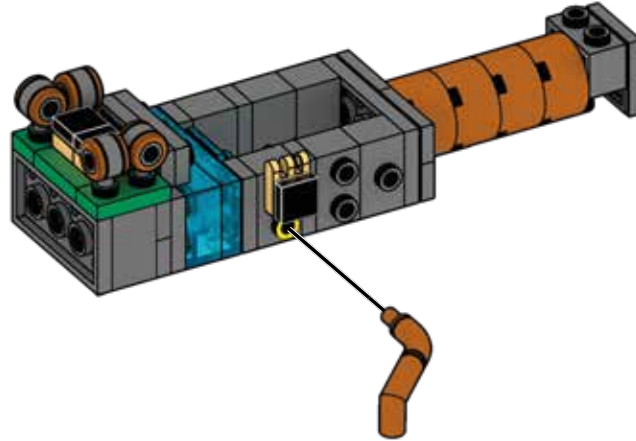

202



2x



2x



1



2

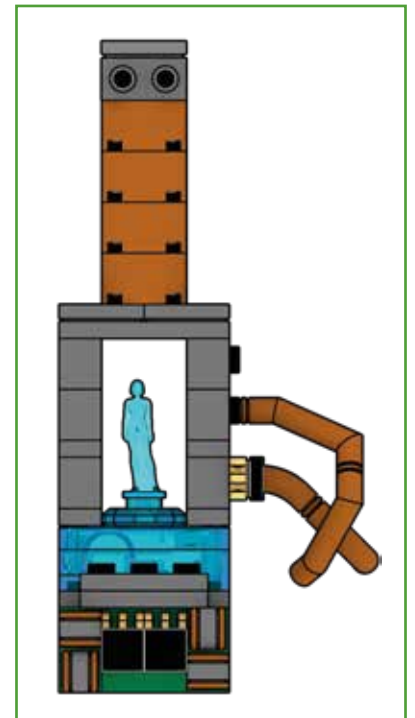
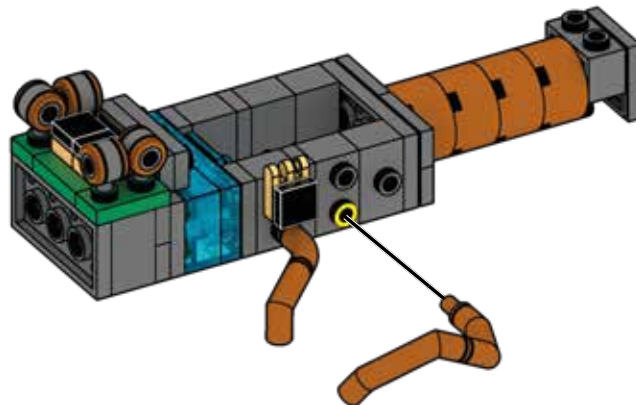

203

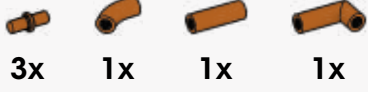

1



2



3

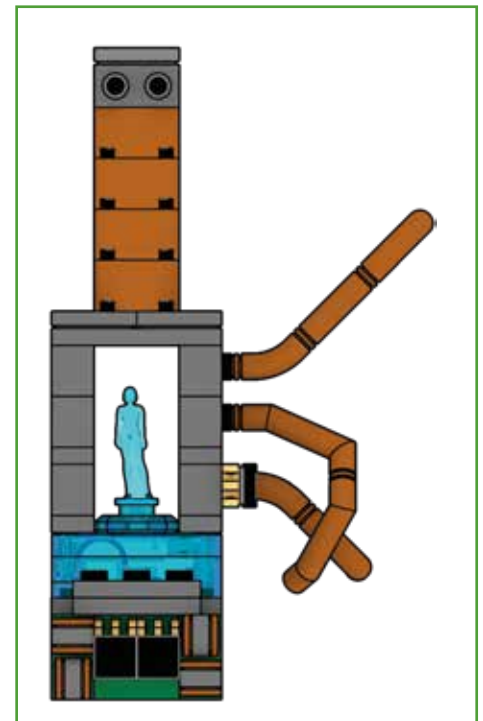
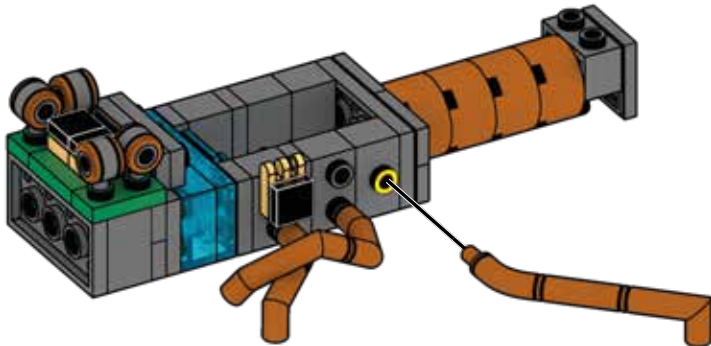

204



3x



3x

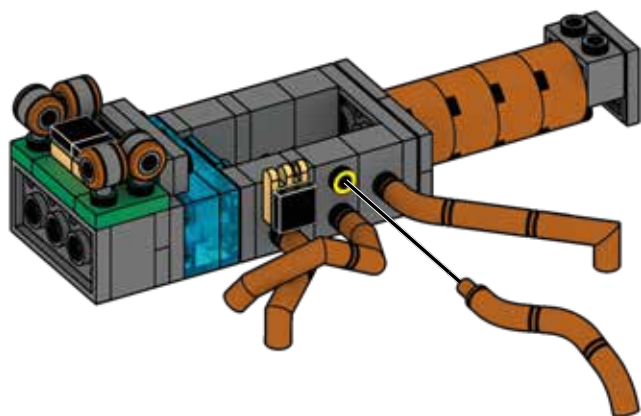
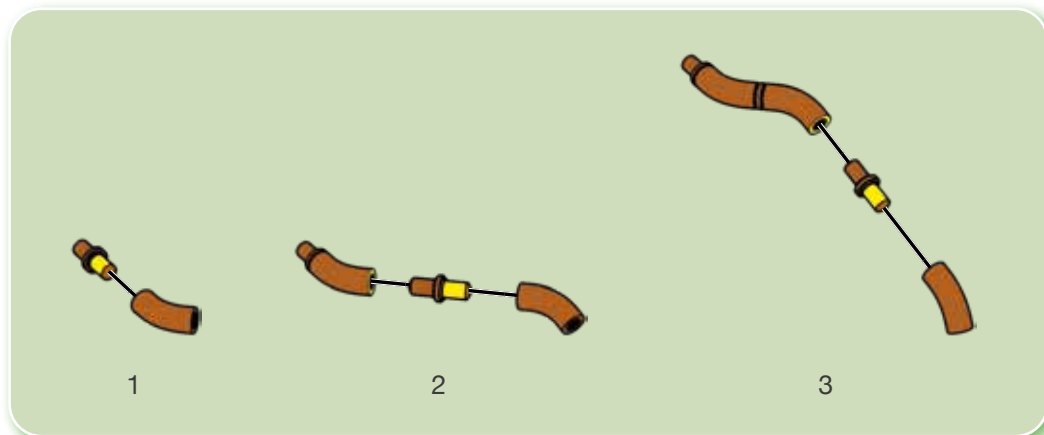

1

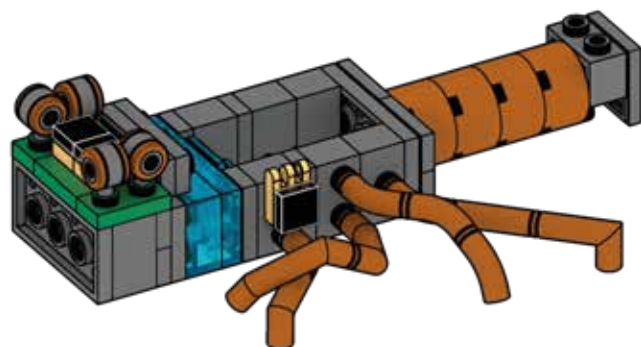

2

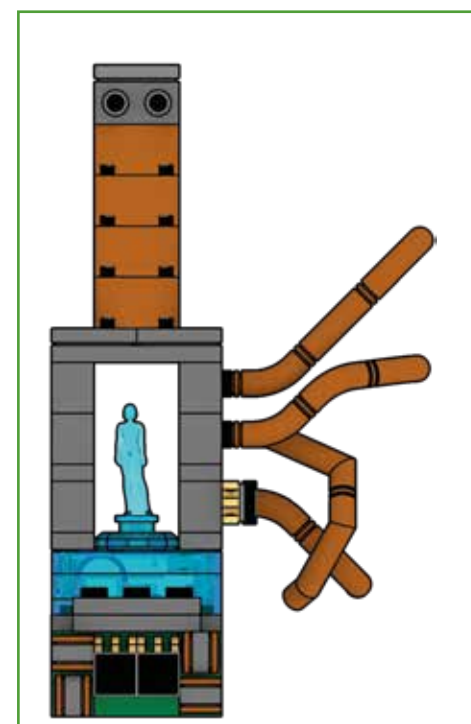

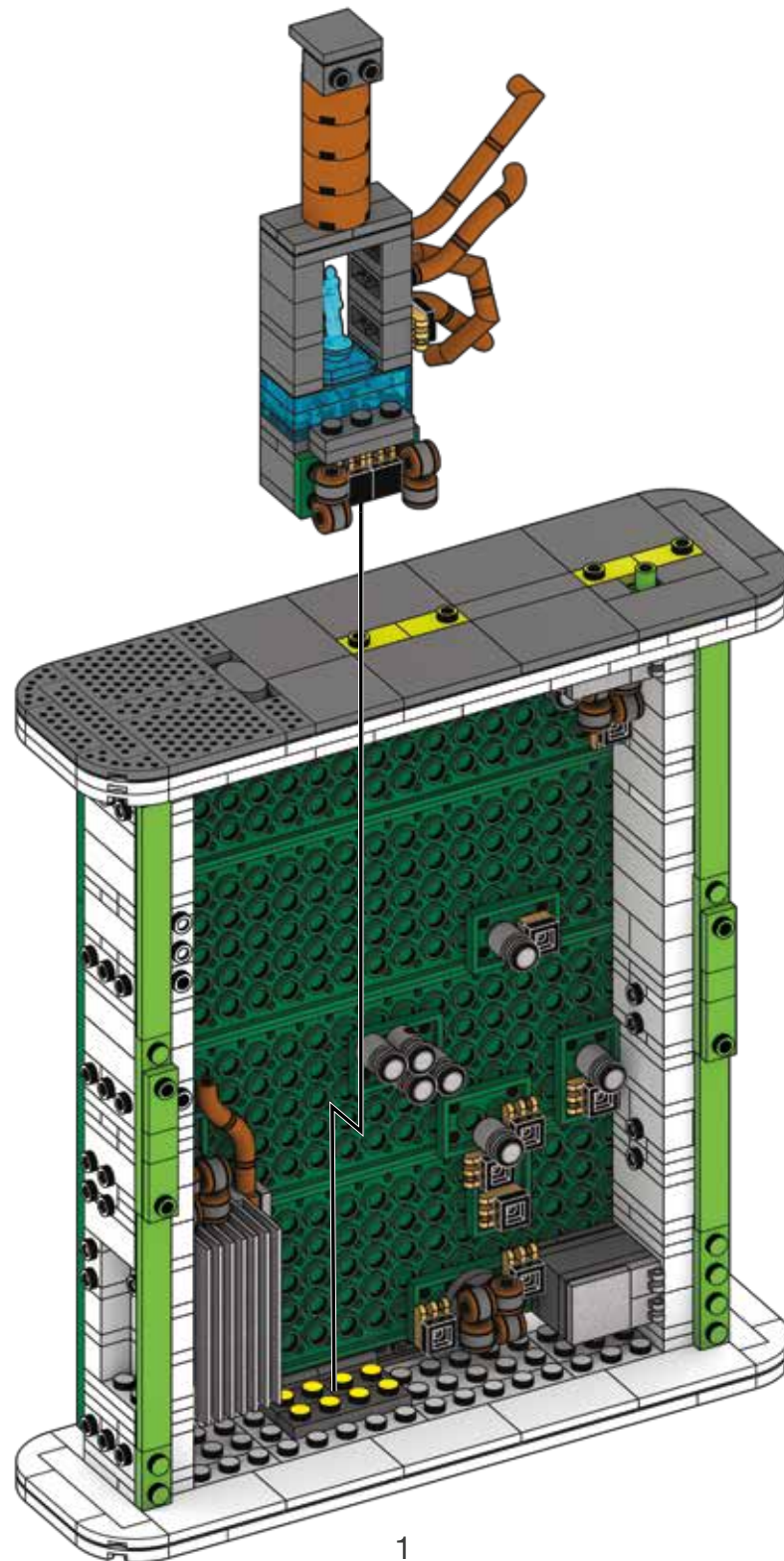

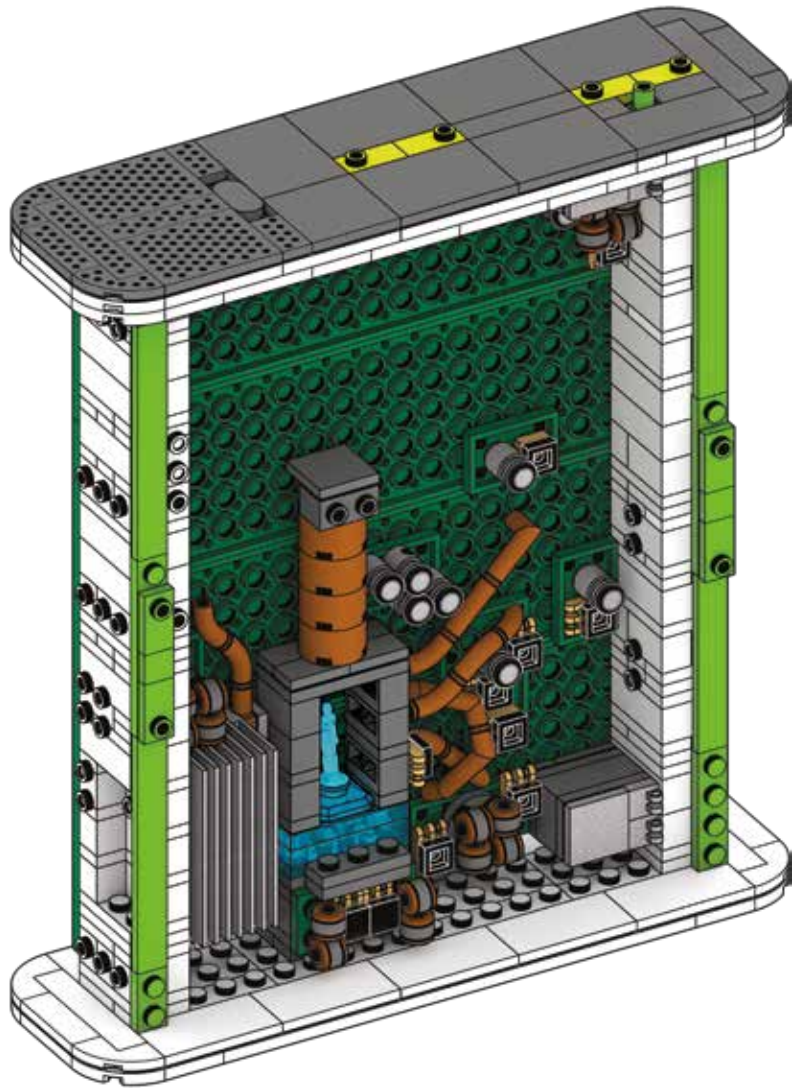

2

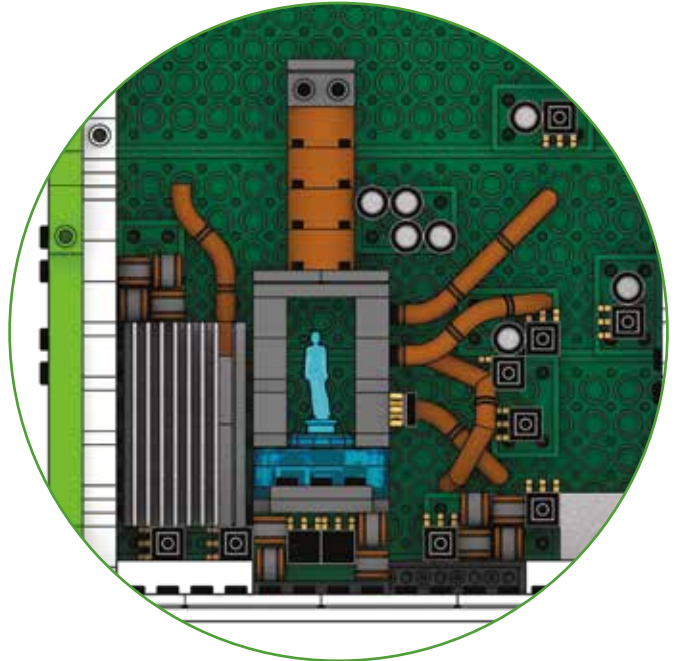

206



207



208

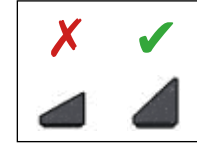

209



210

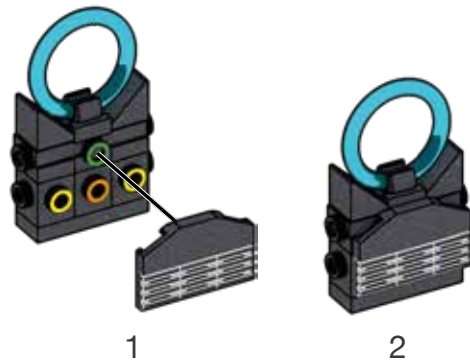

211



212



213

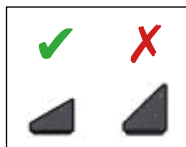

214

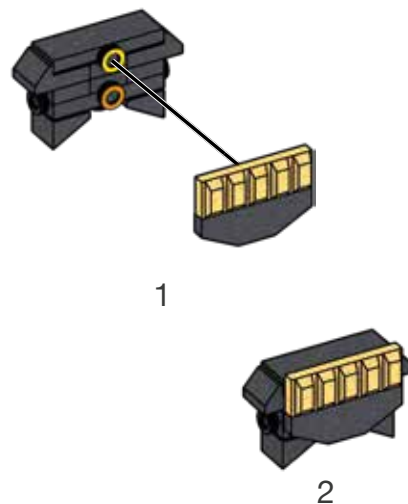

215

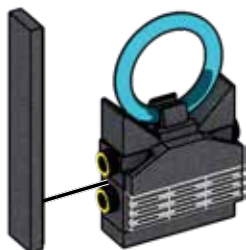

216

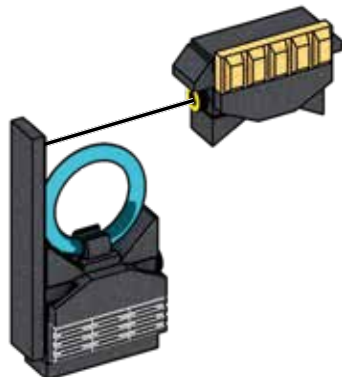

217

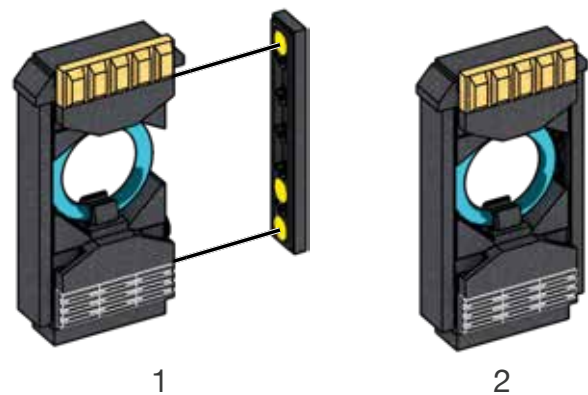

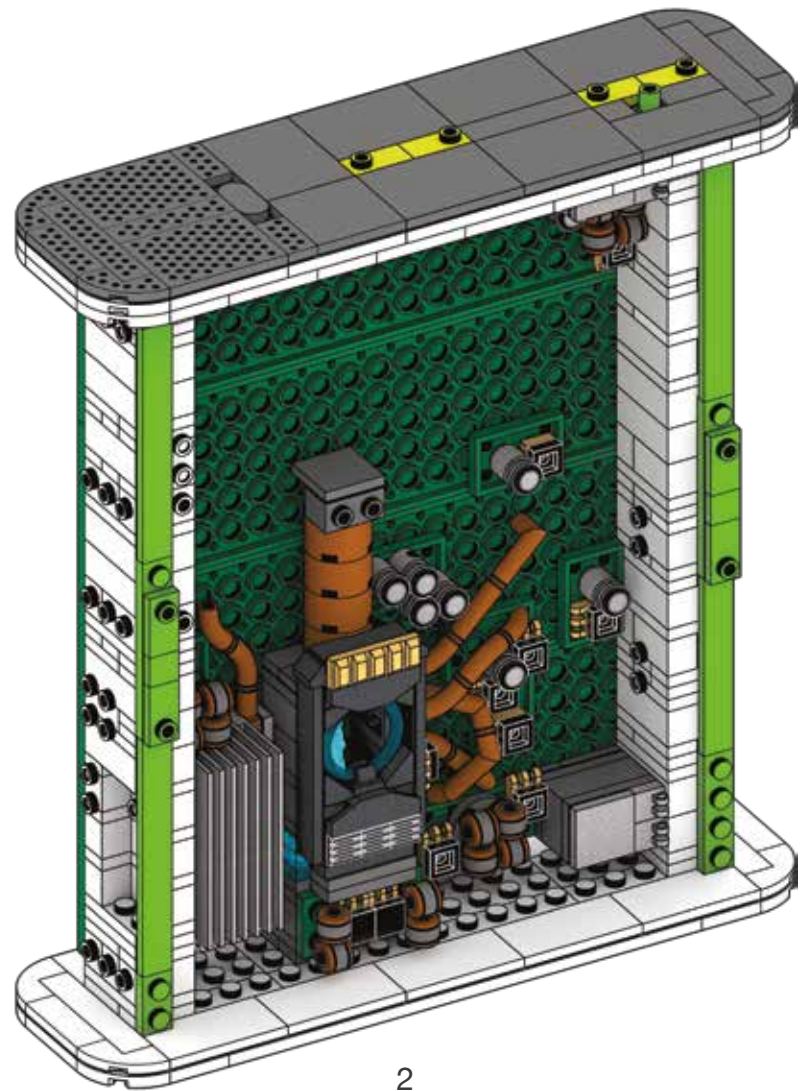
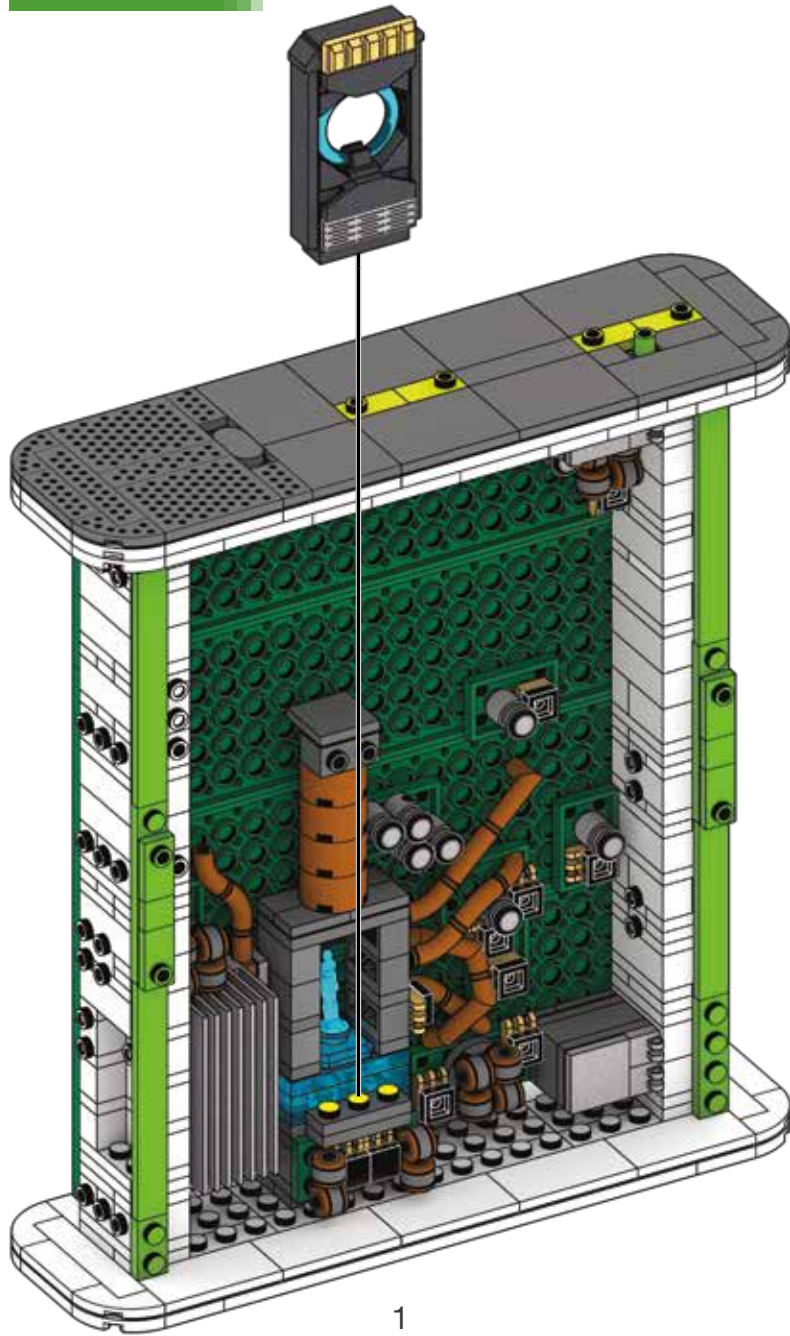

219



1x

5x

1x

1x



220



1x

1x

1x

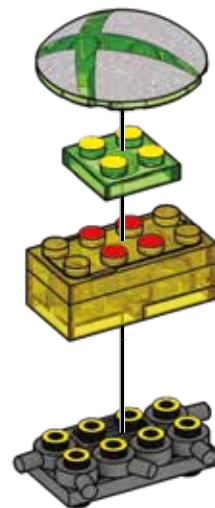
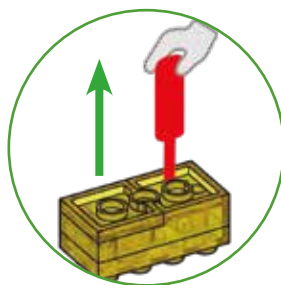

221



1x

1x

1x

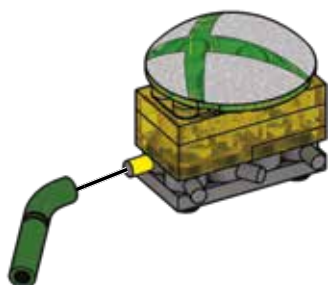
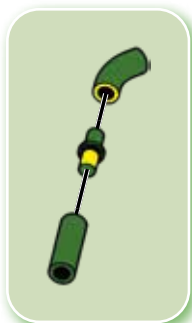

222



1x

2x

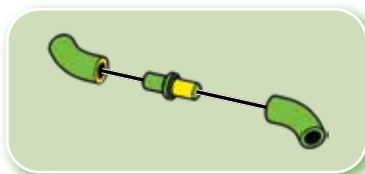

223



224

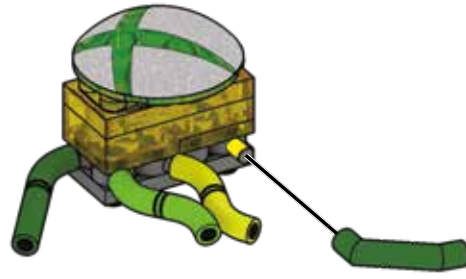
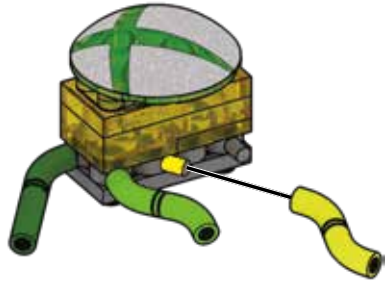
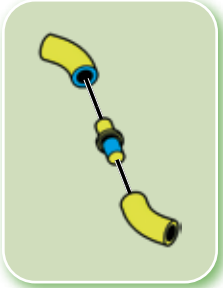

225

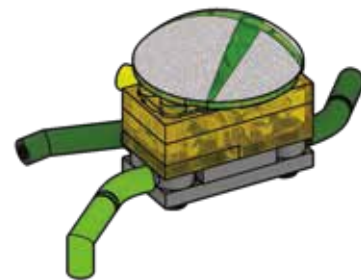
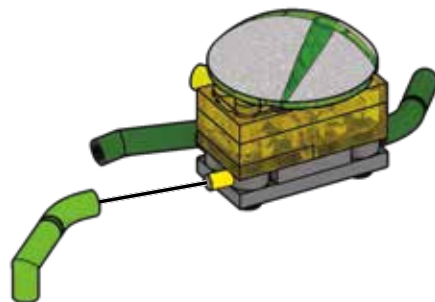

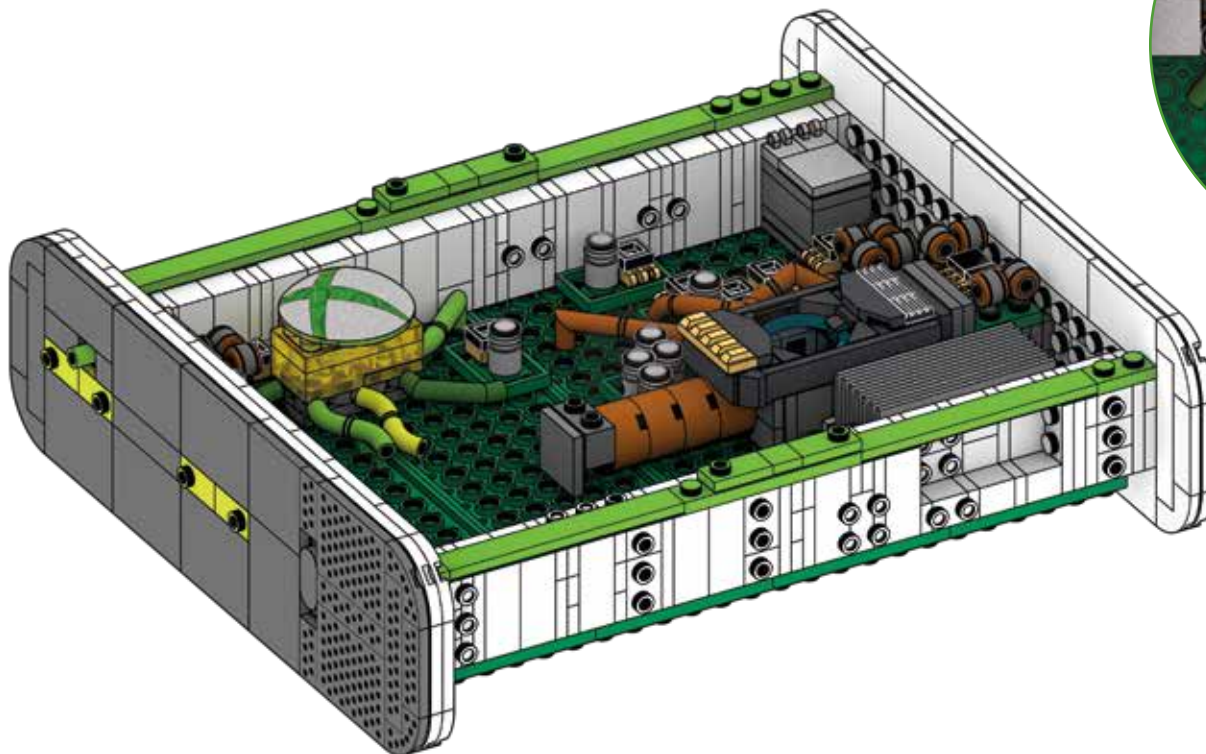
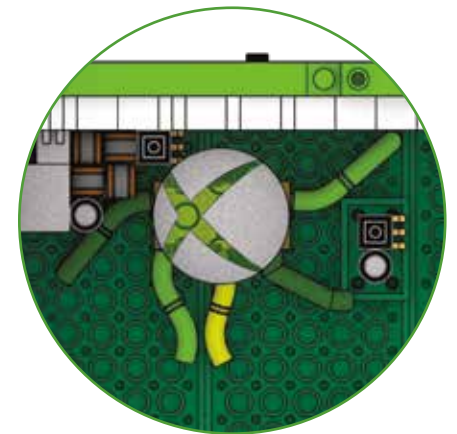
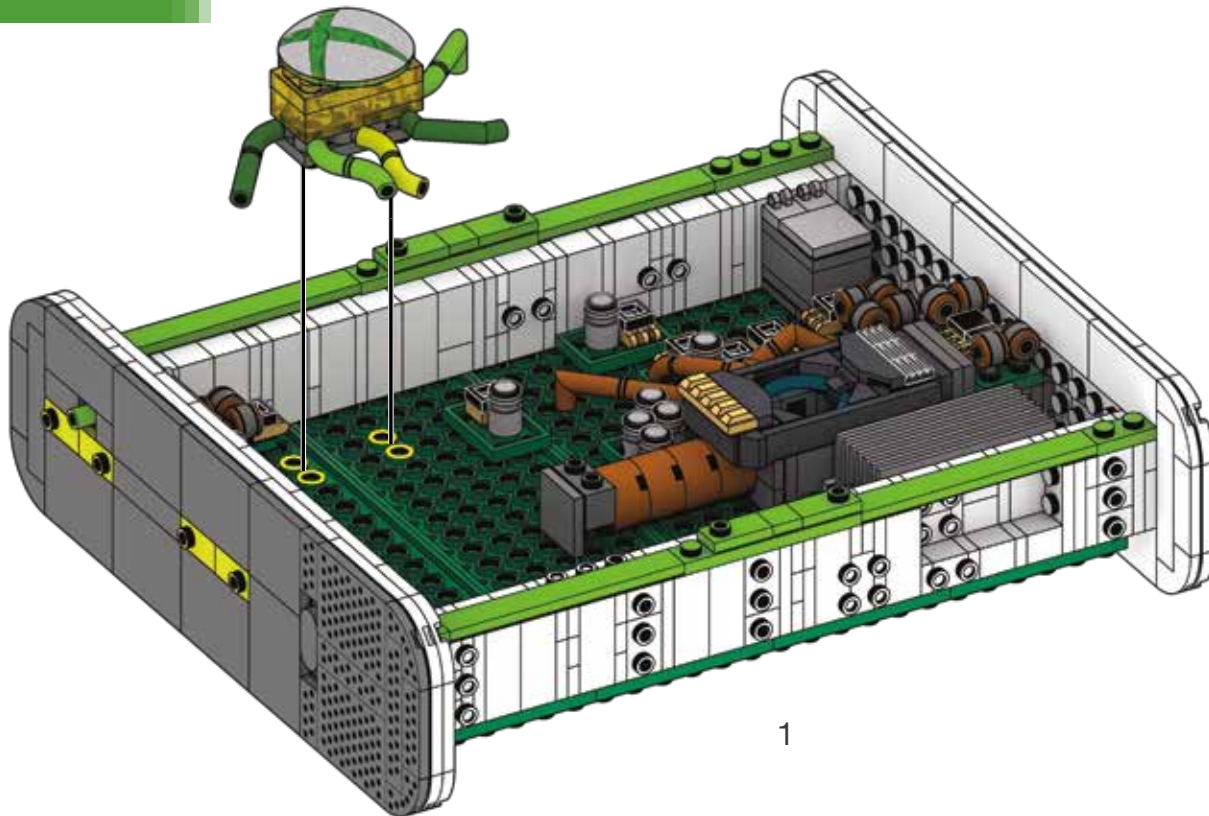



227



2x



2x



2x

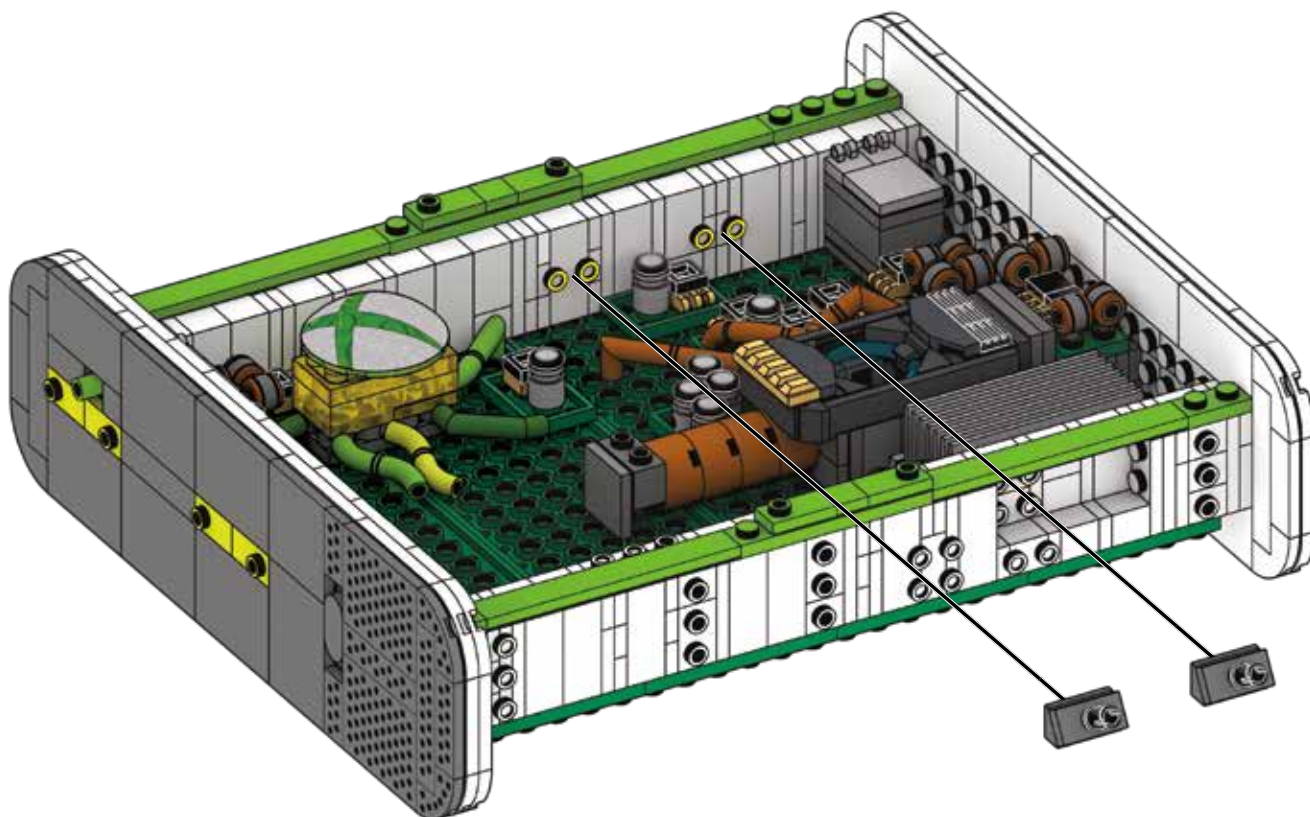
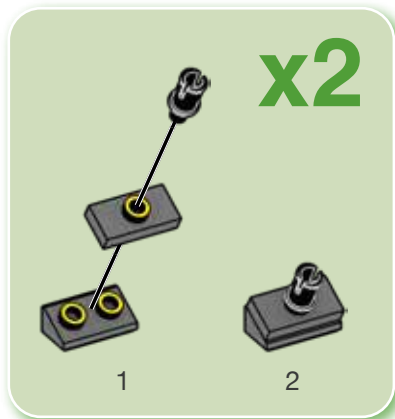

228



2x

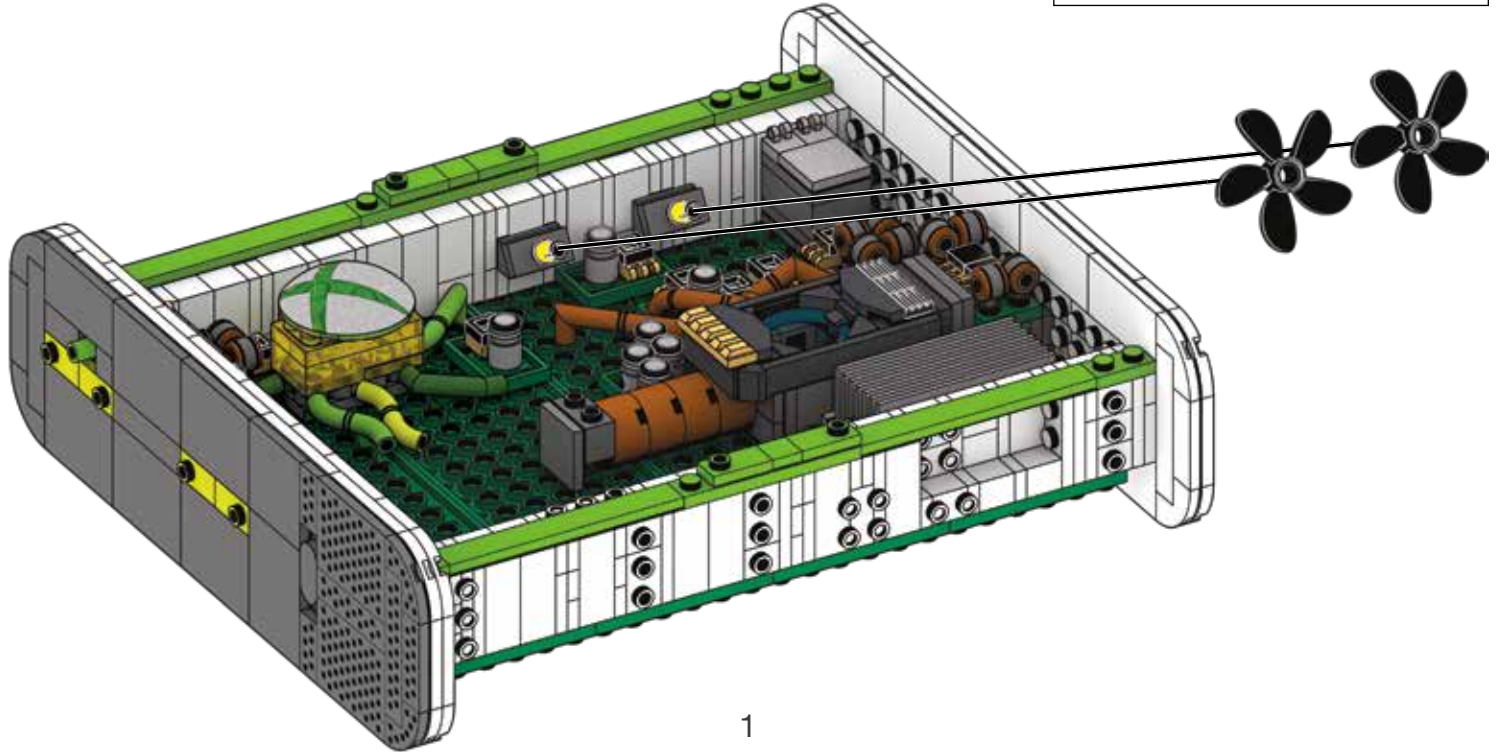
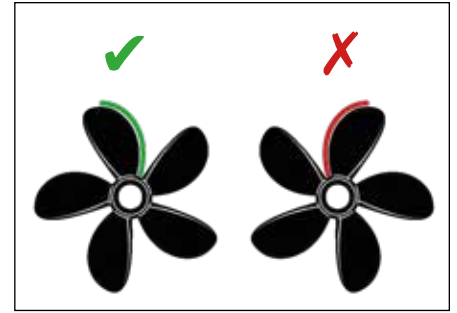

1

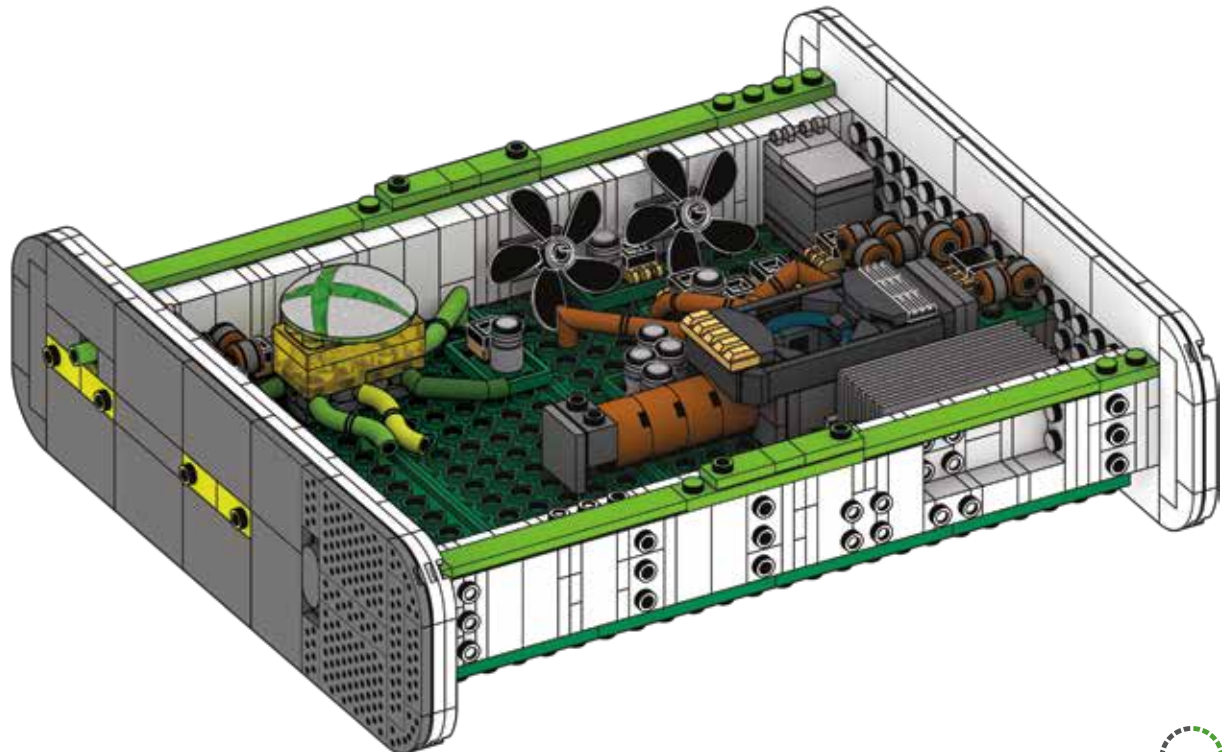

2



229

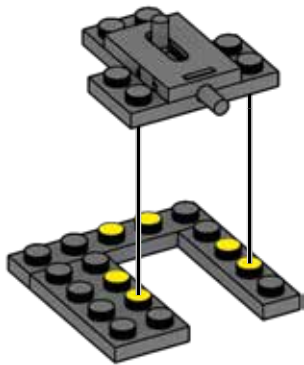
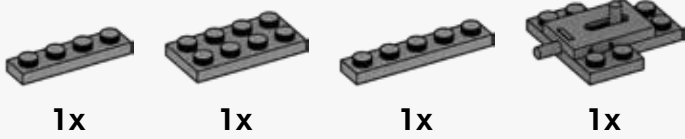

230

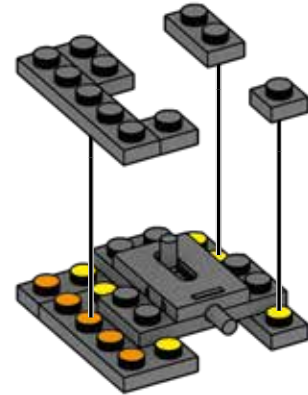

231

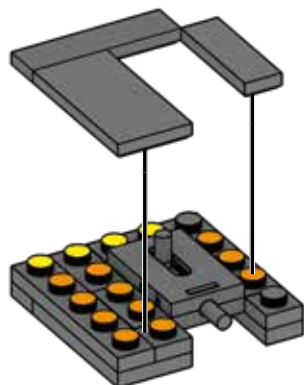
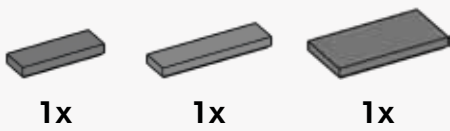

232



2x

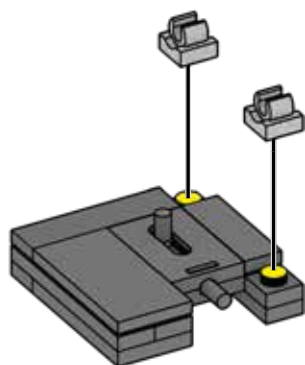

1

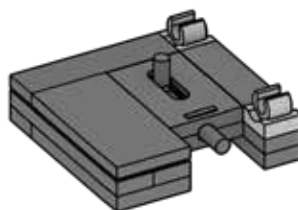

2

233



4x



2x



1



2

x2

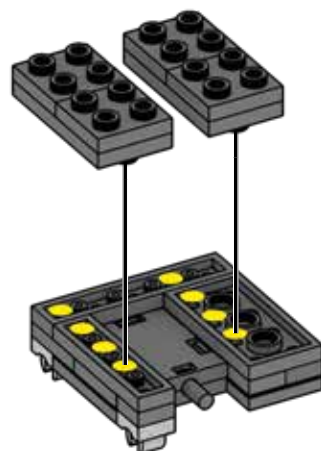

1

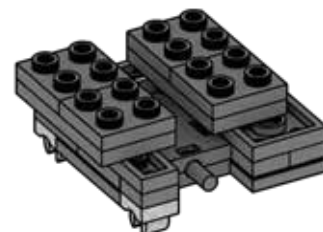

2

234



2x

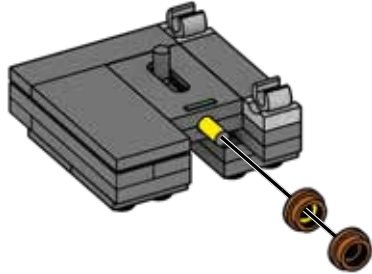

235



1x



1x



1x



1x

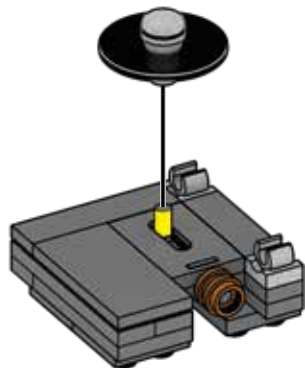
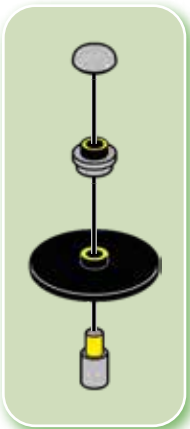

1



2

236

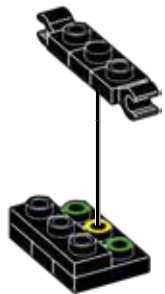
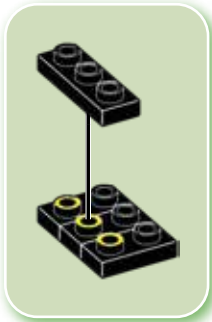

237



238

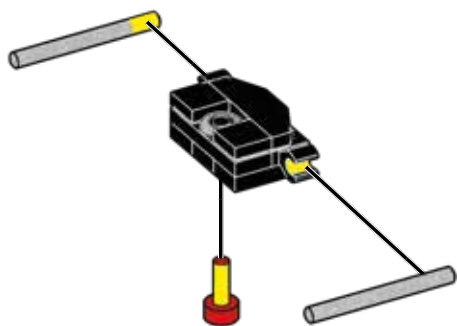
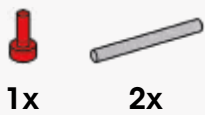

239

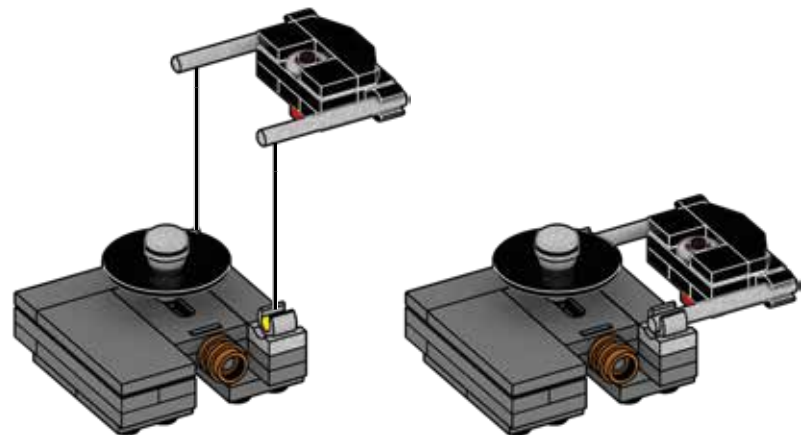

1

2

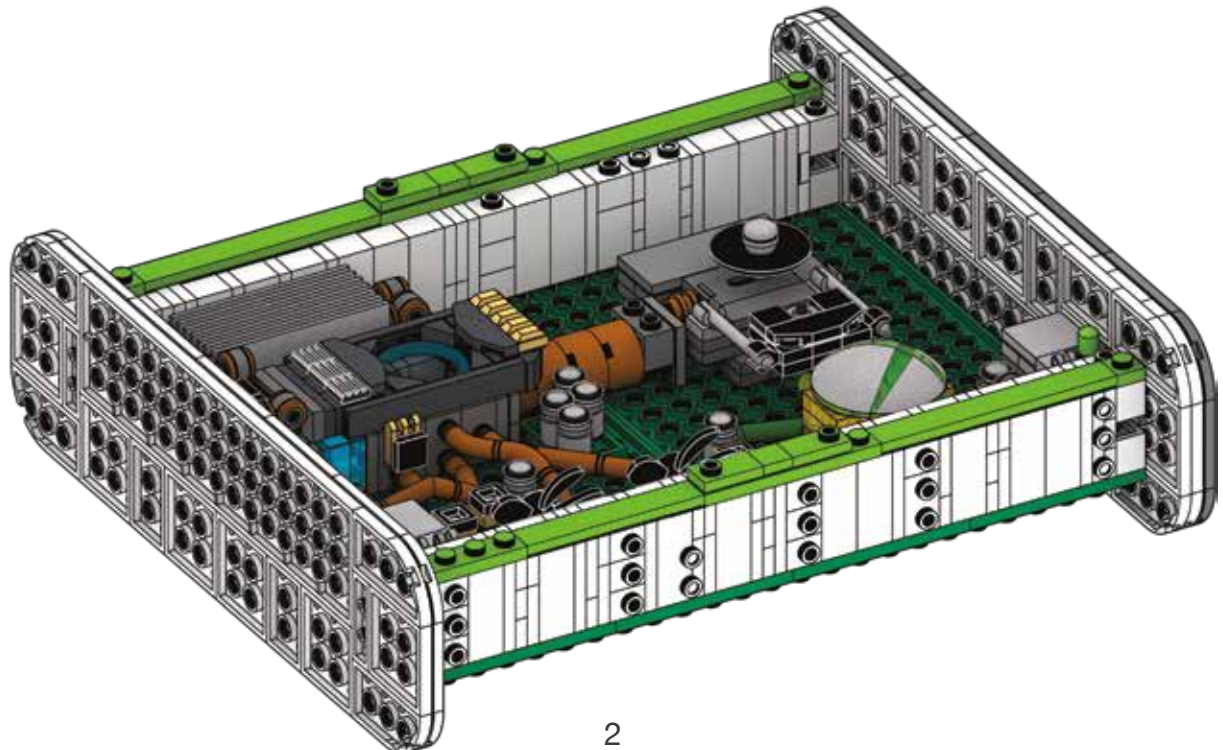
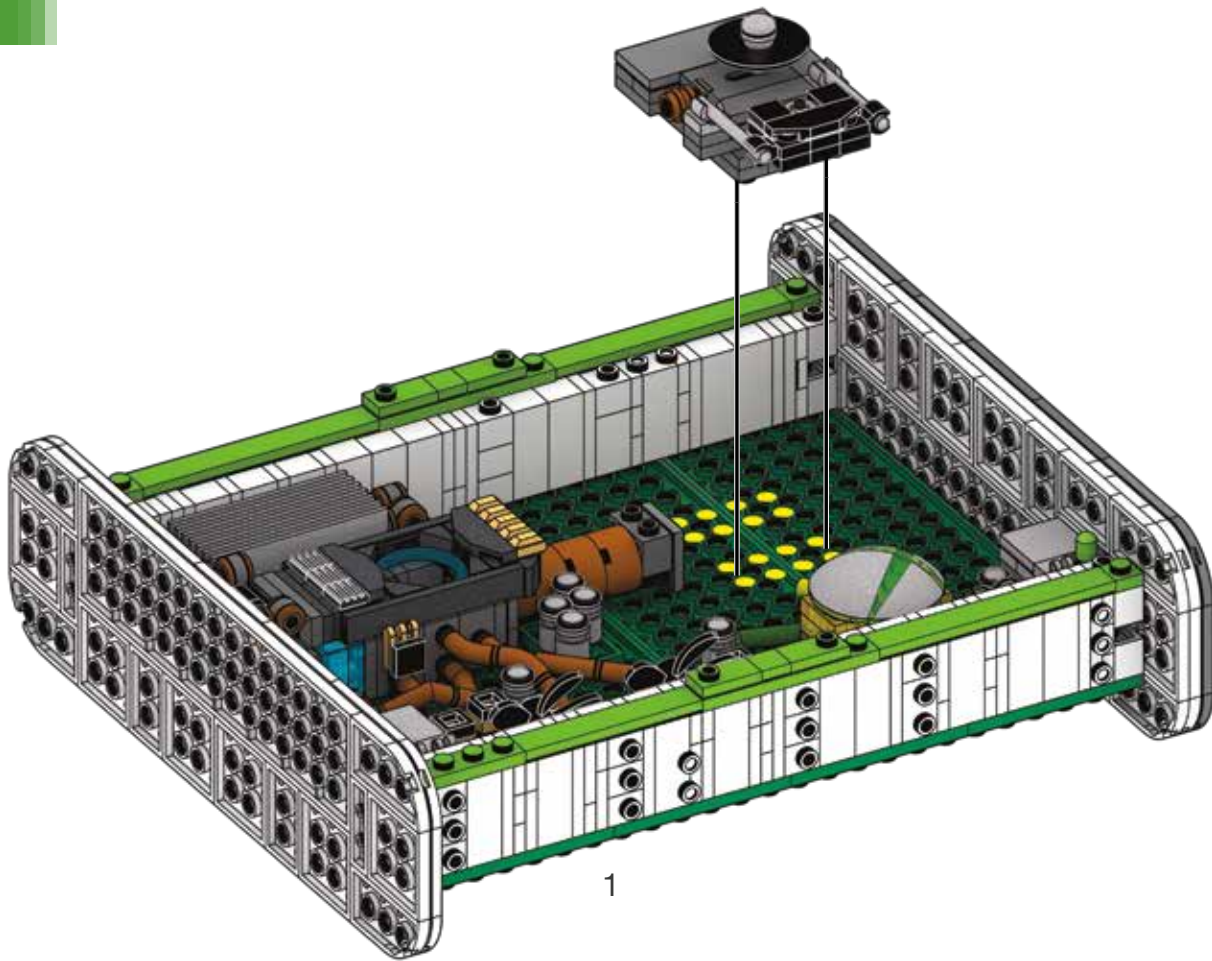

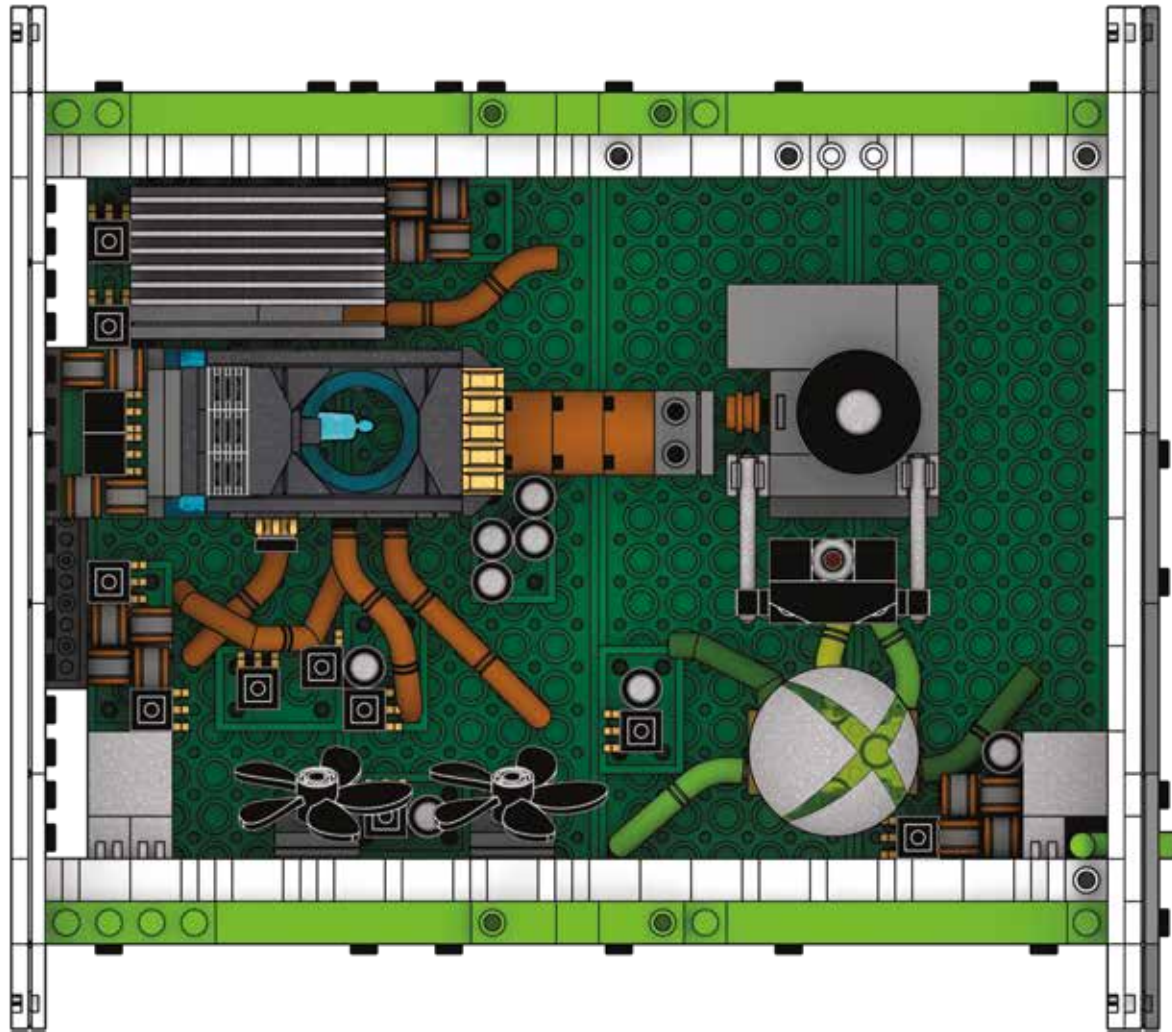

241



2x



2x



1x



1x

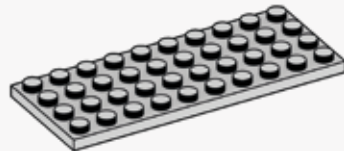

2x

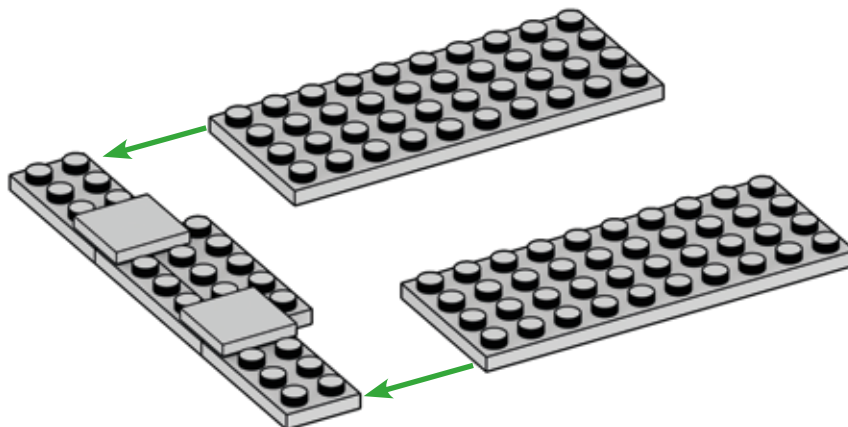
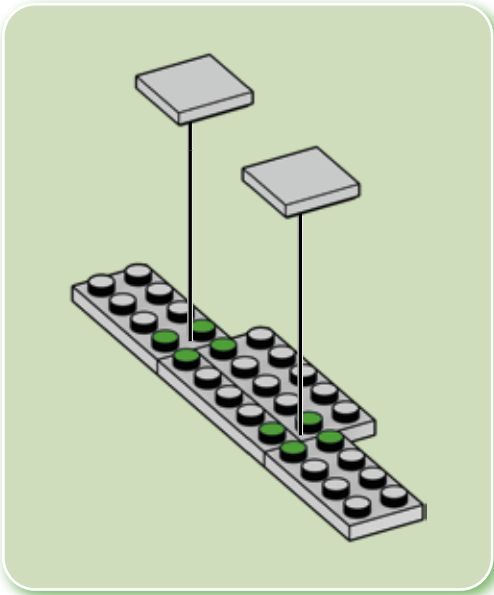

242



2x

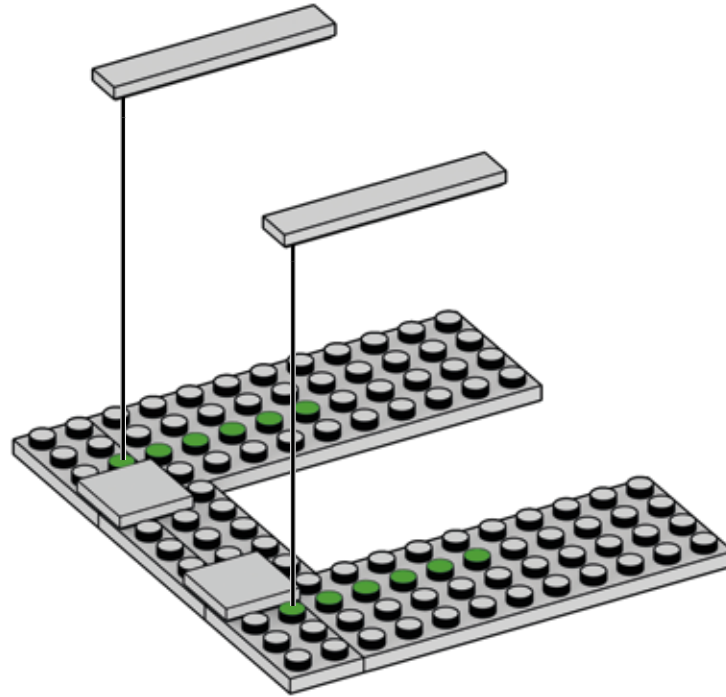

243



3x

2x

1x

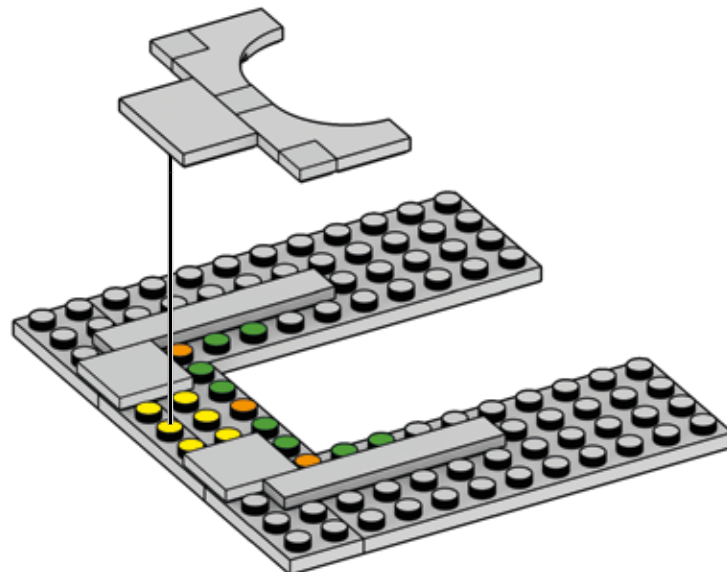

244



1x



1x



2x



2x

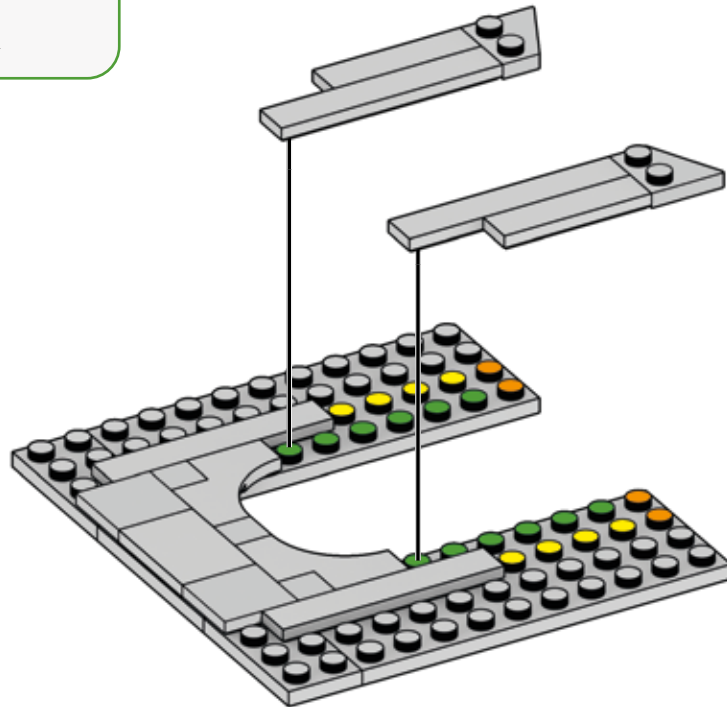

245



1x



1x



2x



1x



1x

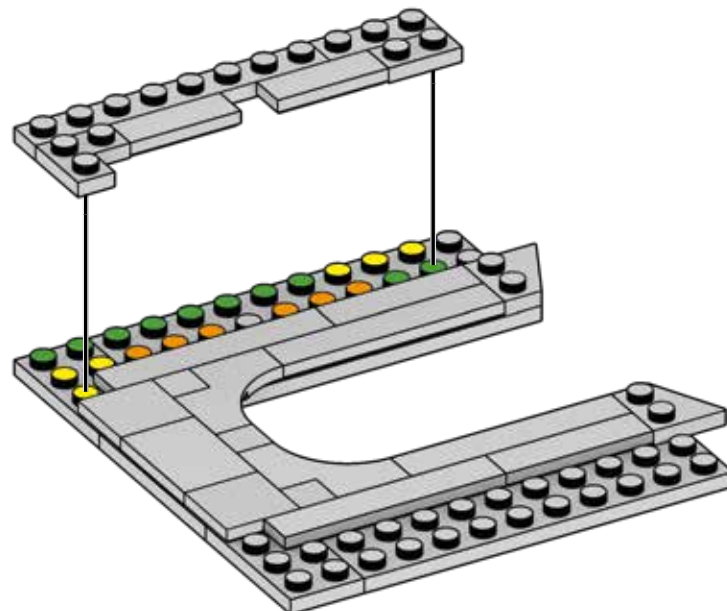

246

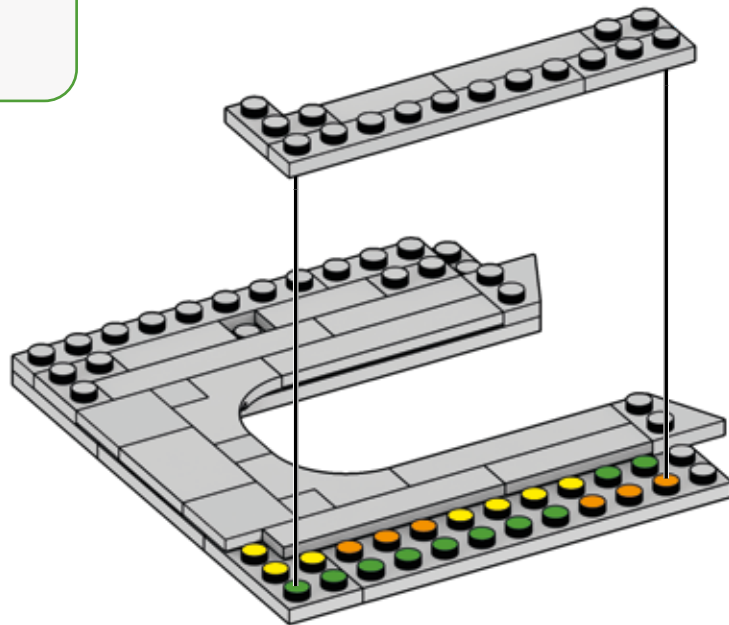
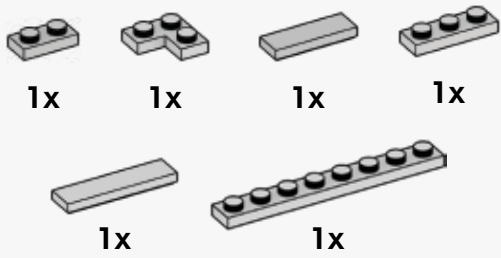

247

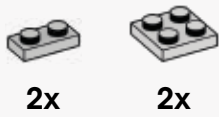

x2

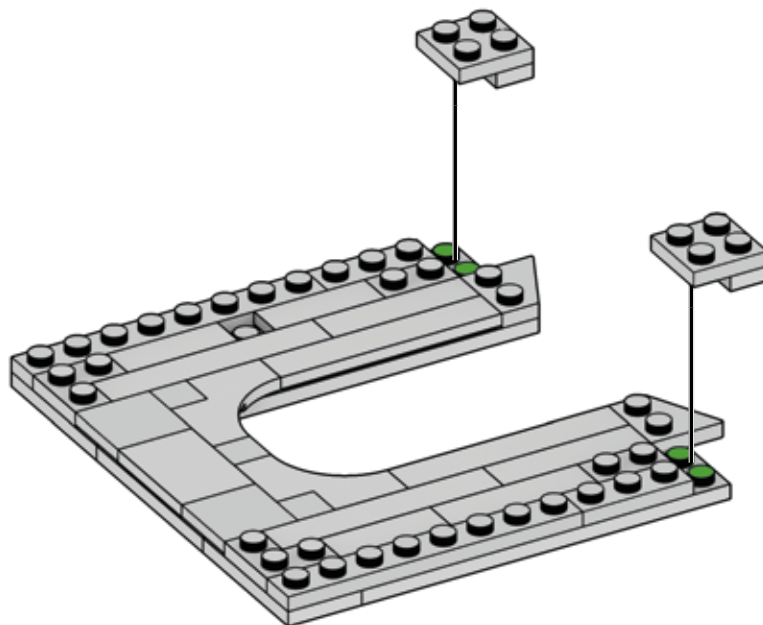

248

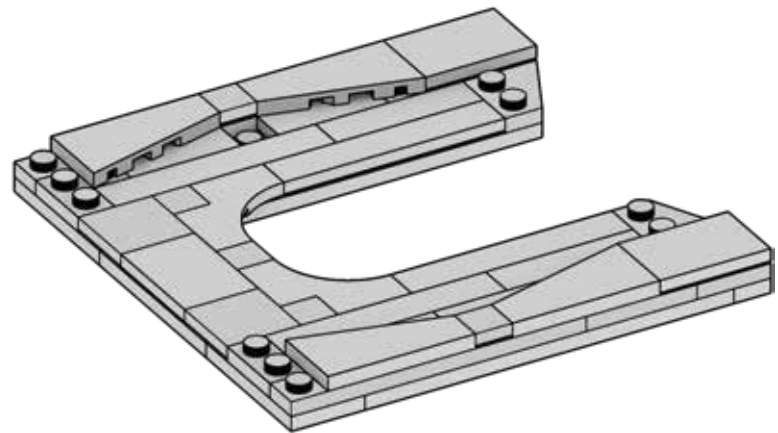
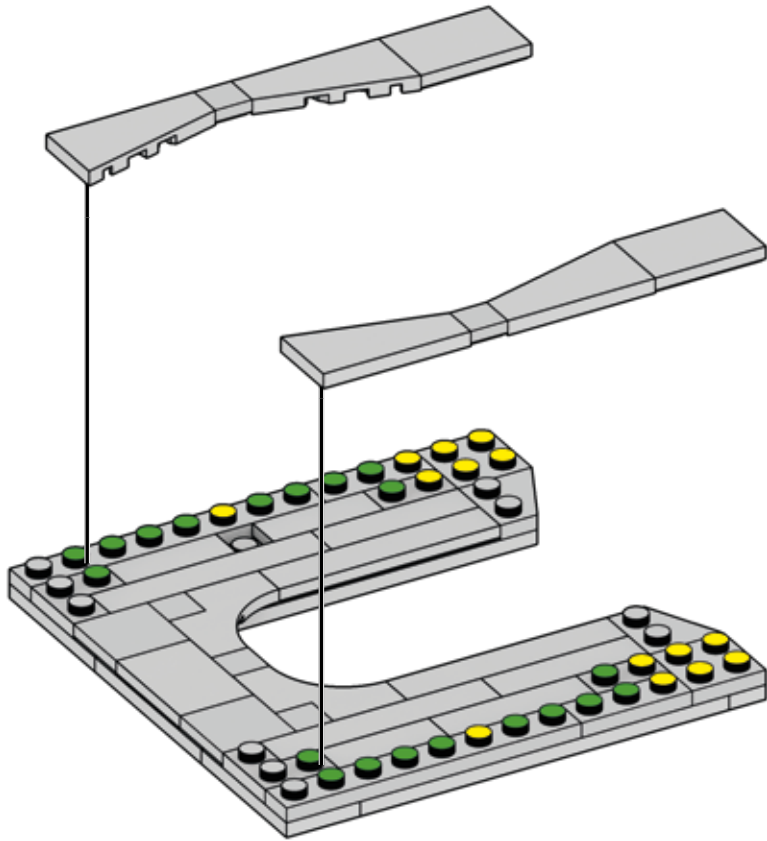
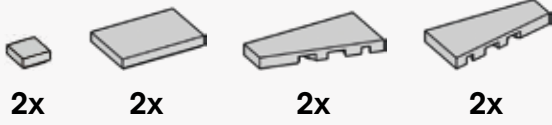

249



2x



2x

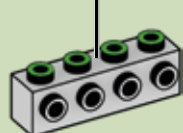

1

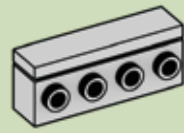

2

x2

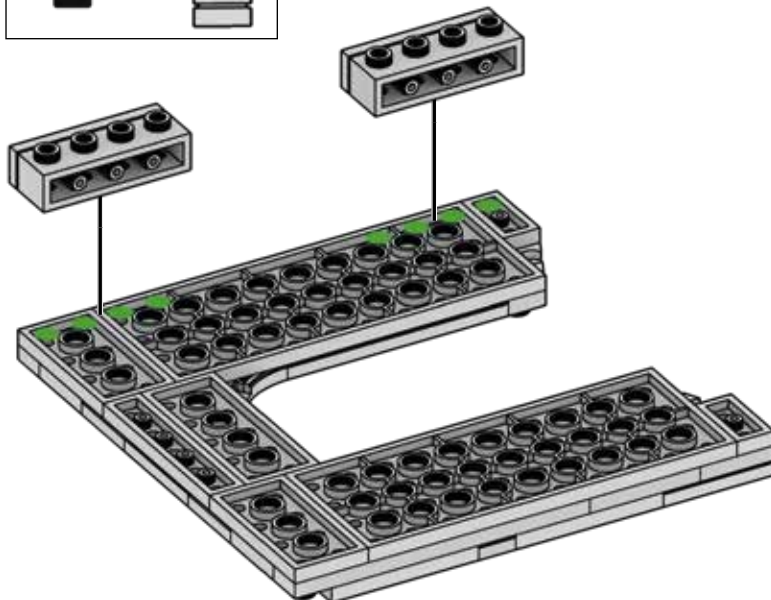
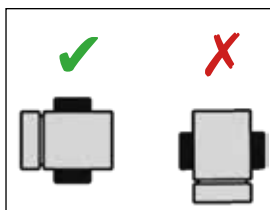

250

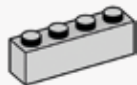

2x

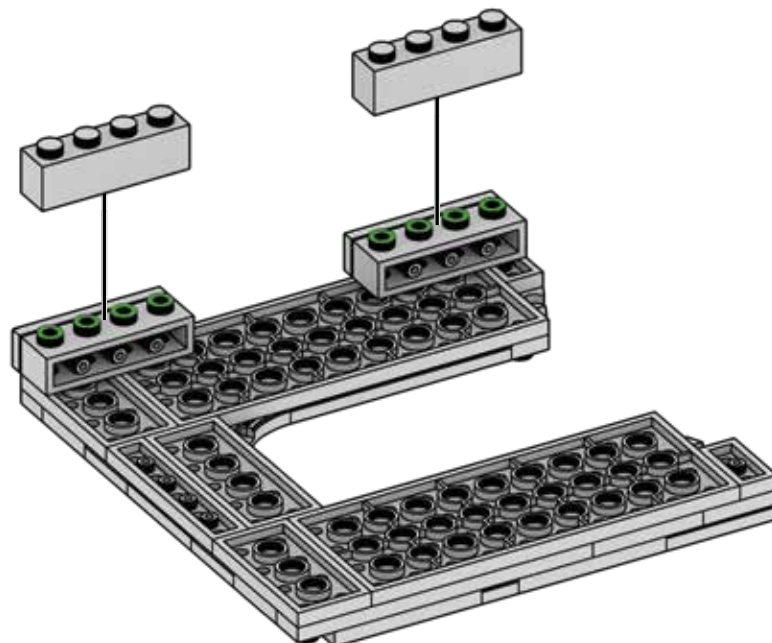

251



1x



1x



1x



3x



1x

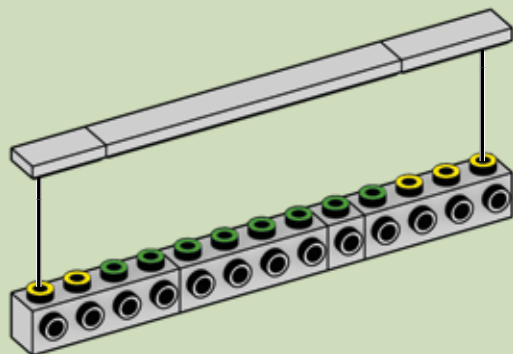

1

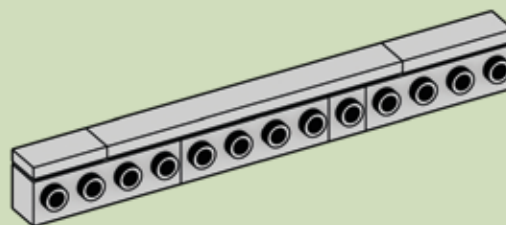

2

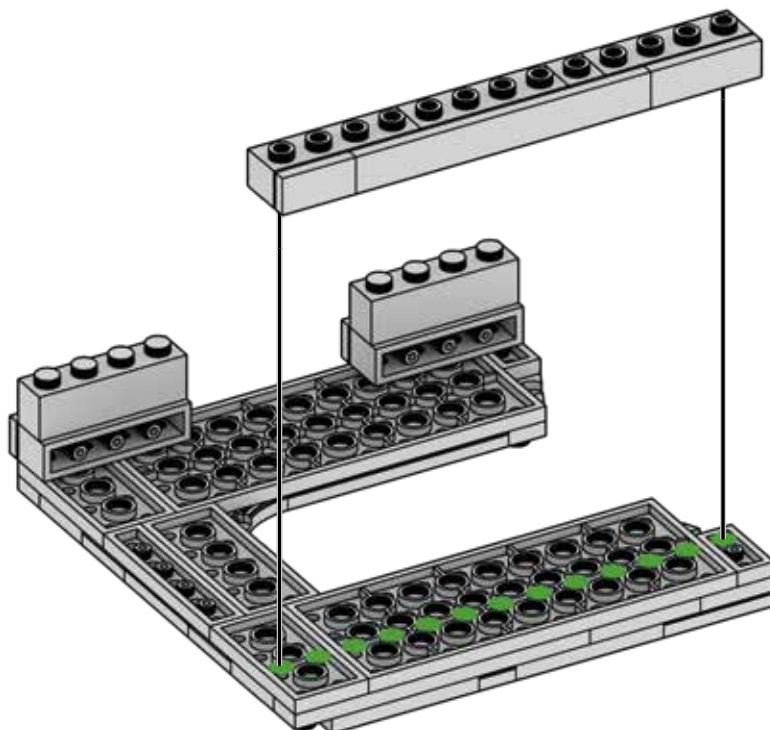

252



2x



2x

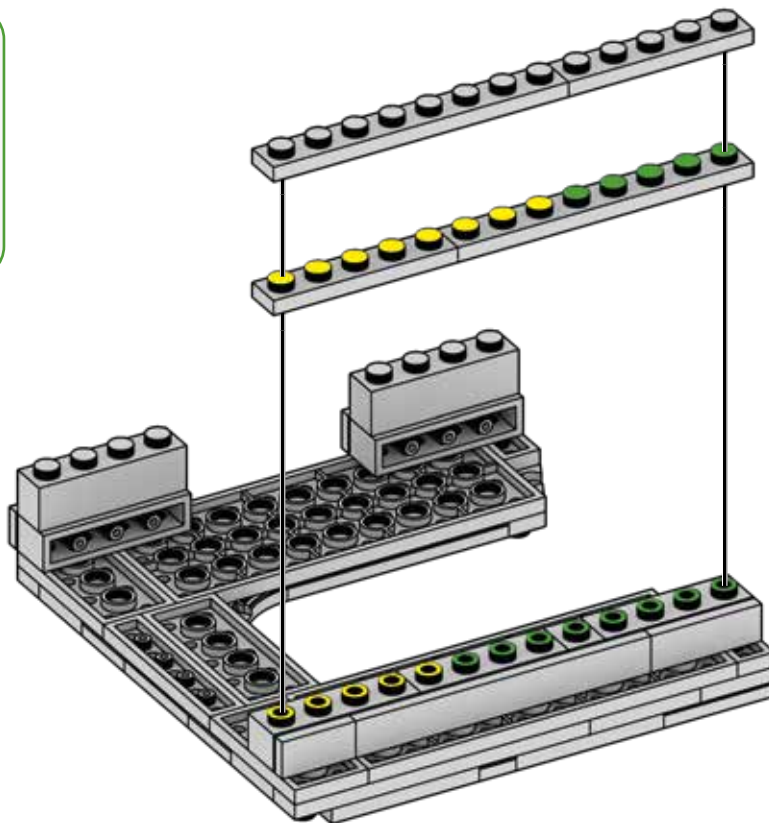

253



1x



1x



2x

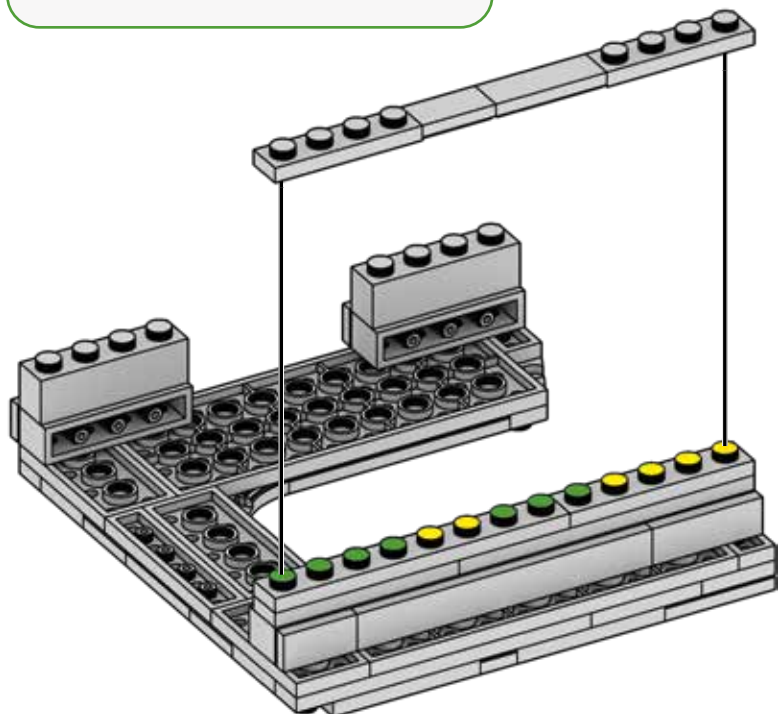

1

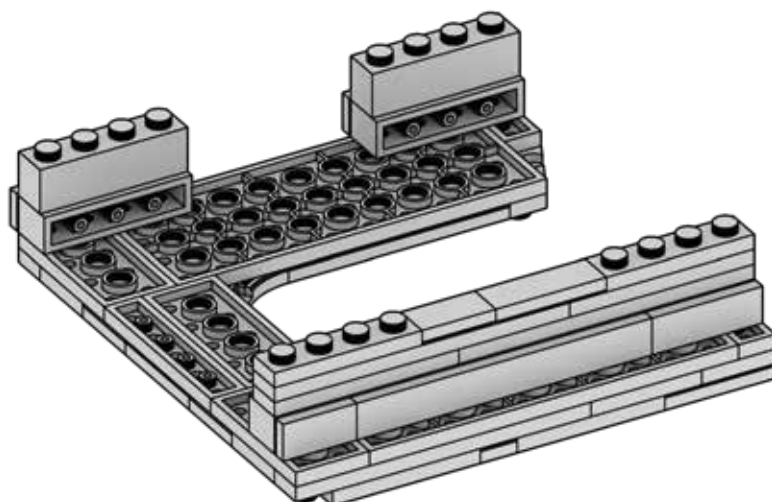

2

254



1x

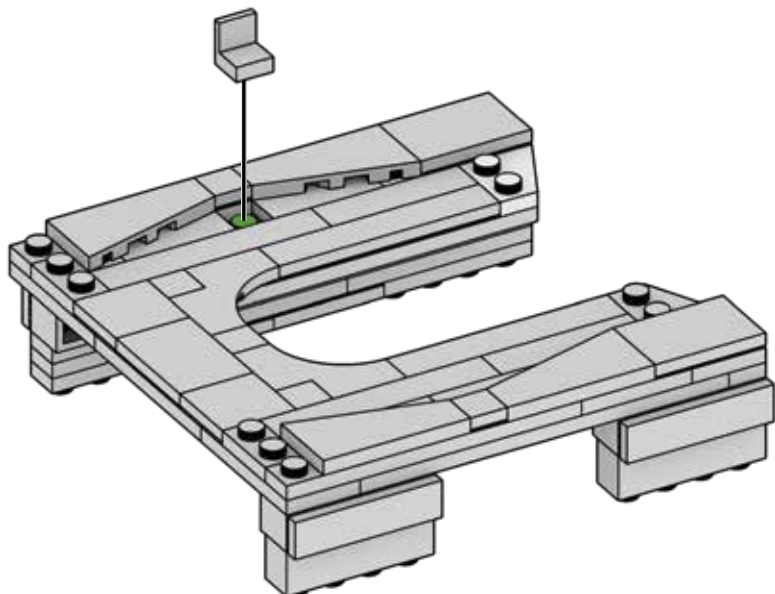

1

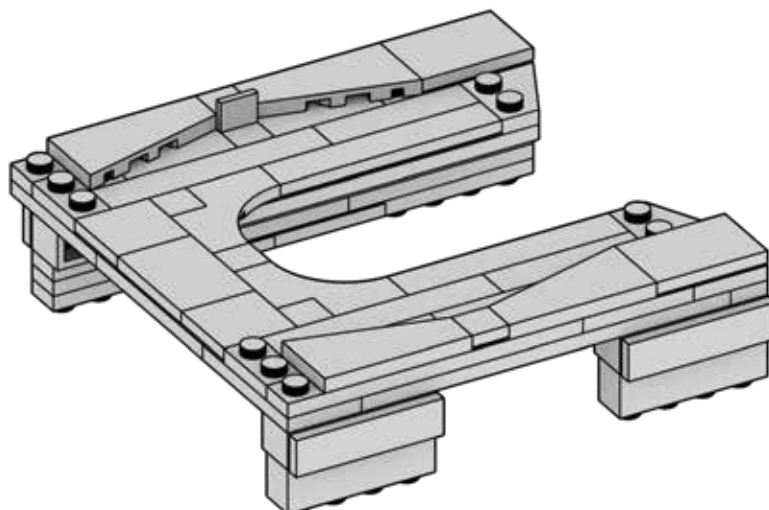

2

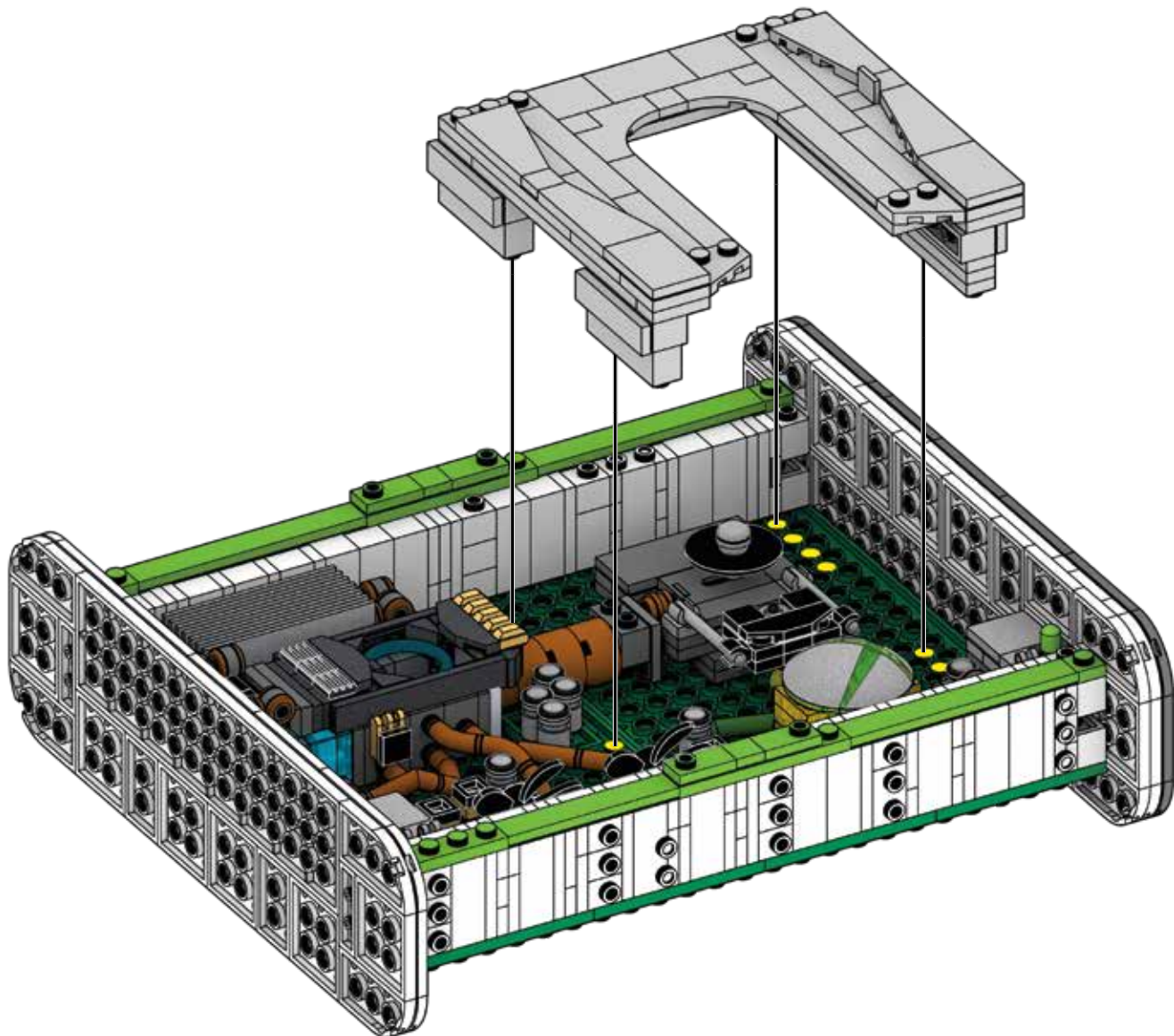

256



1x



2x



1x

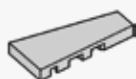

1x

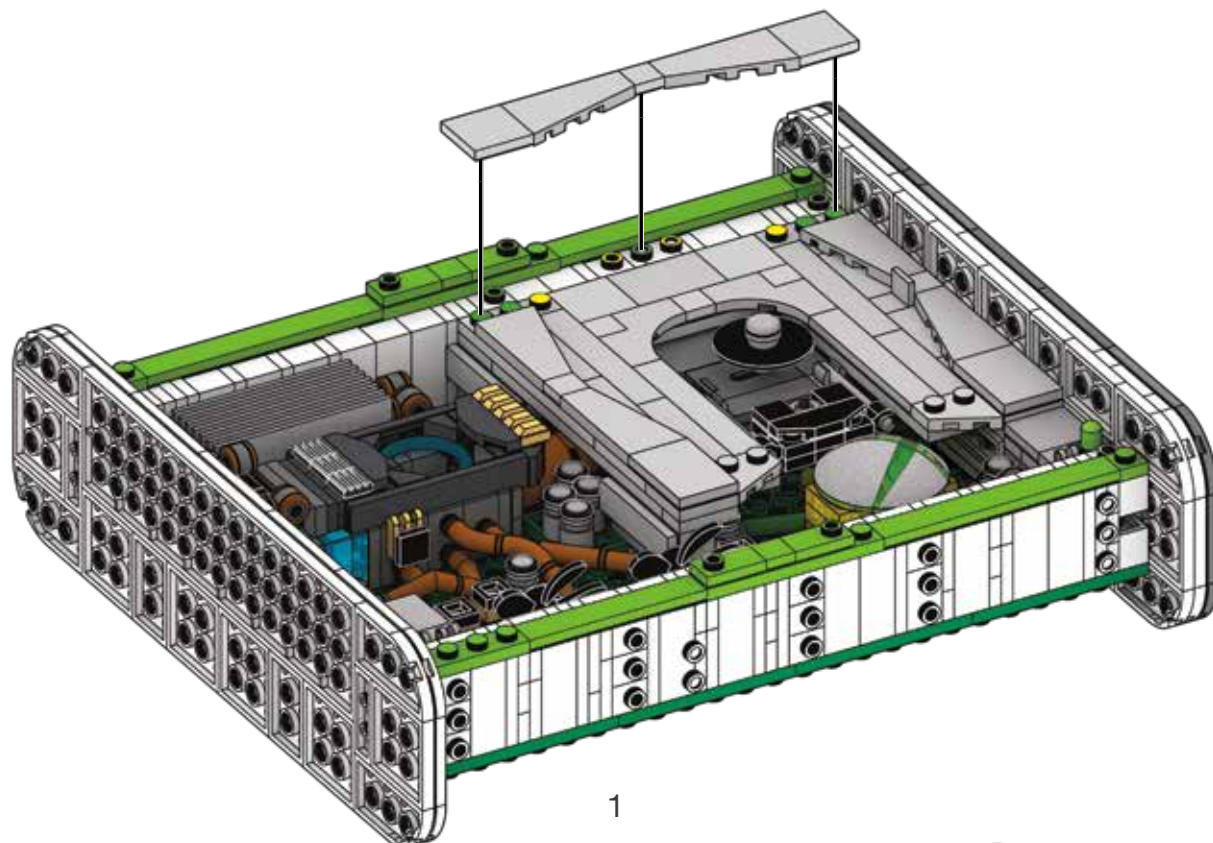

1

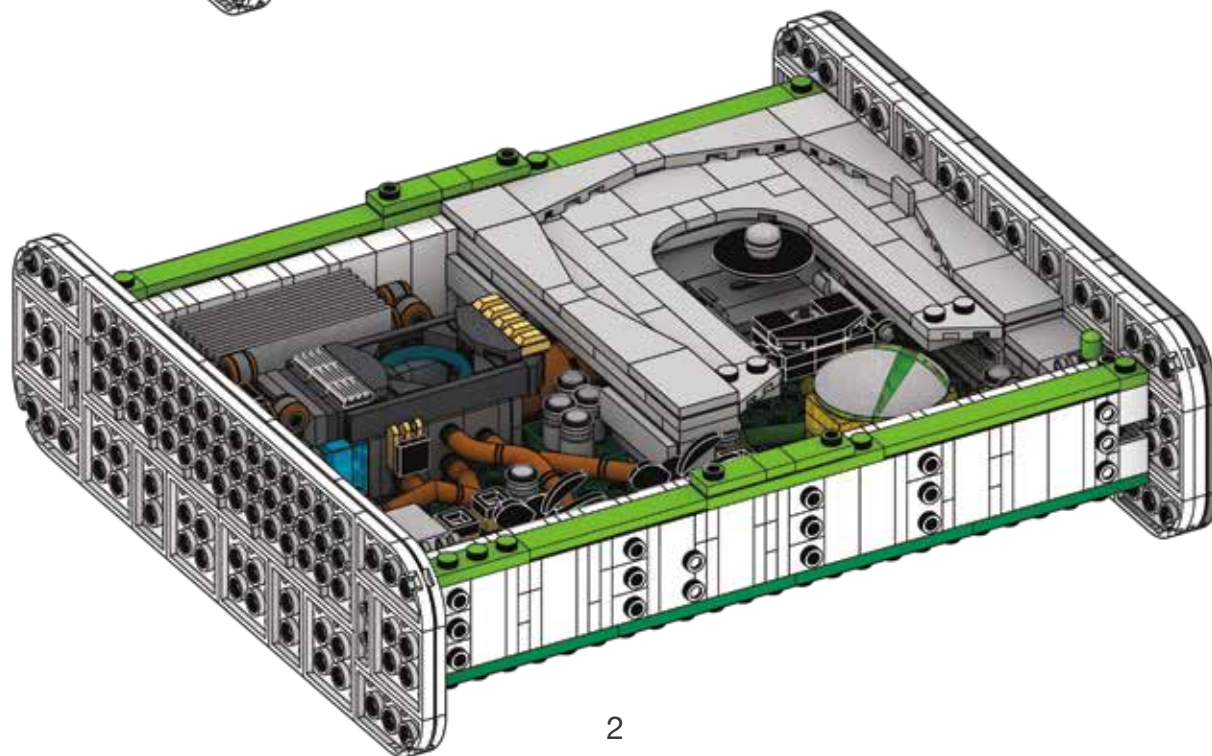

2

75%

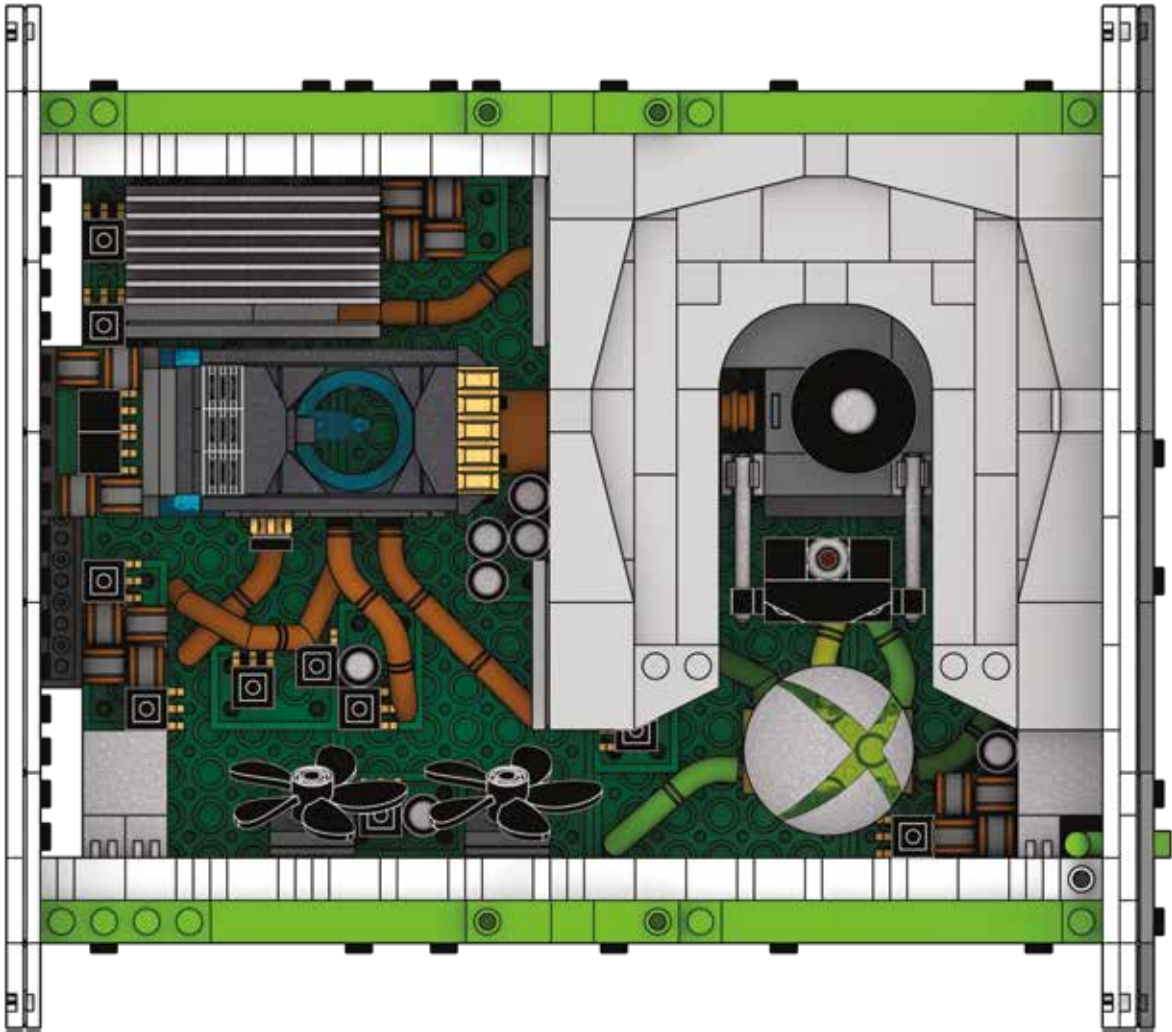



257



1x



1x



2x

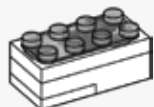

1x

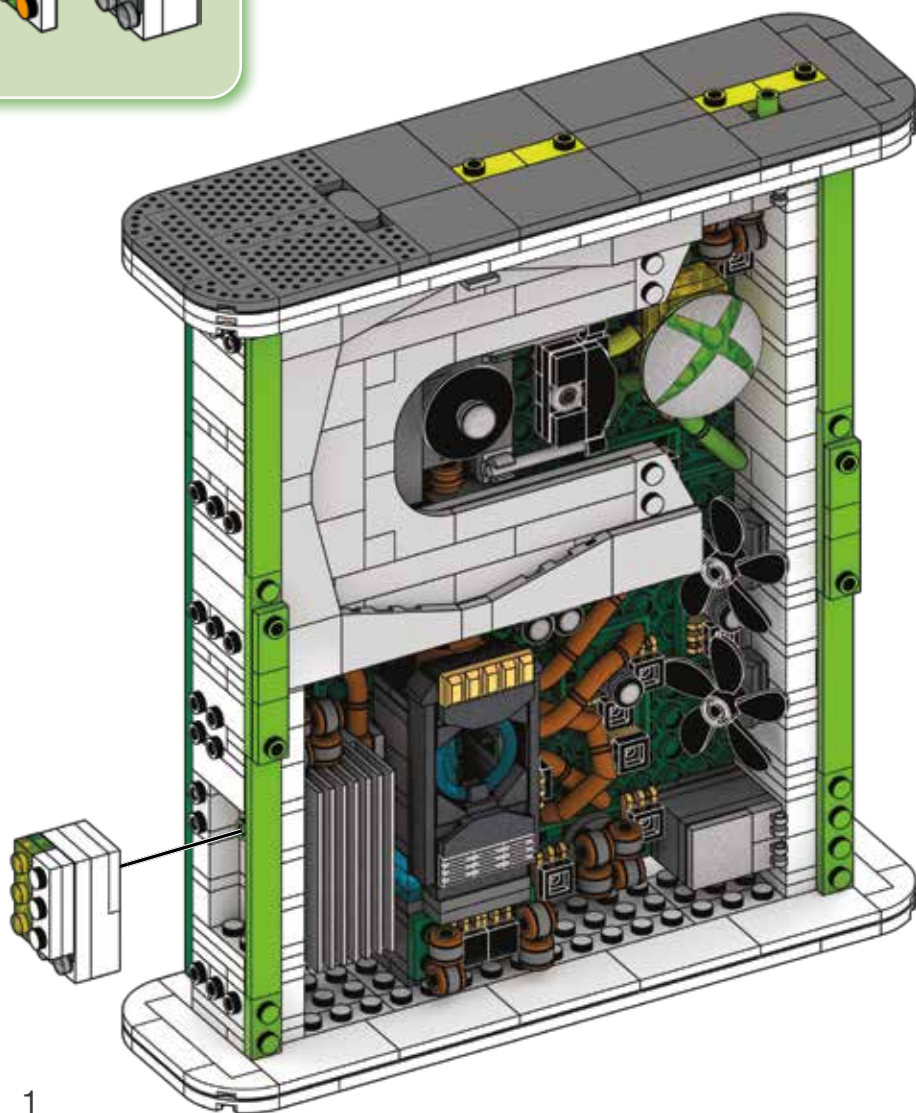
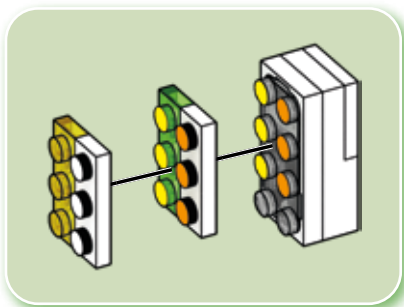
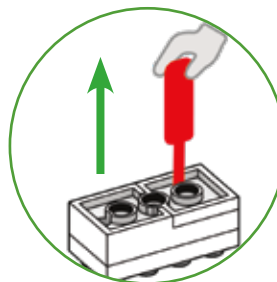

1

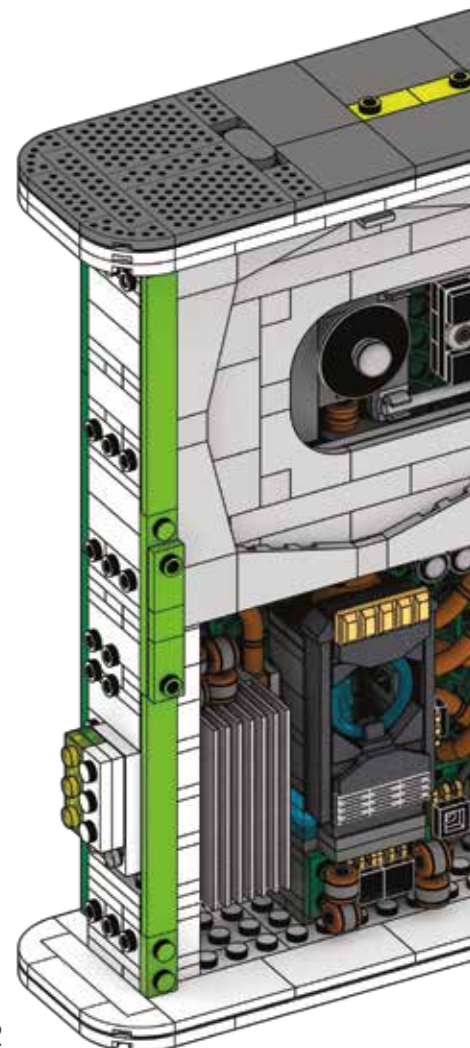

2



258

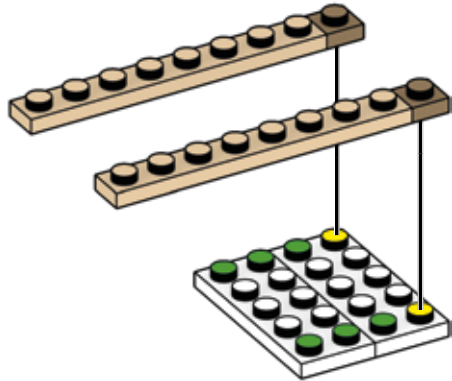
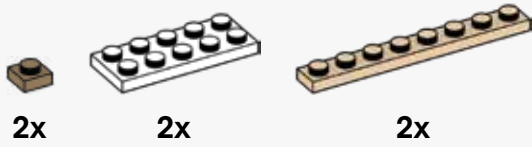

259

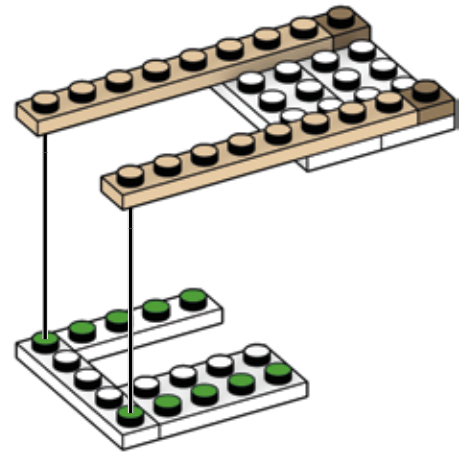
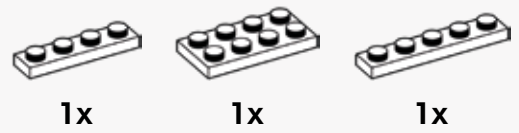

260

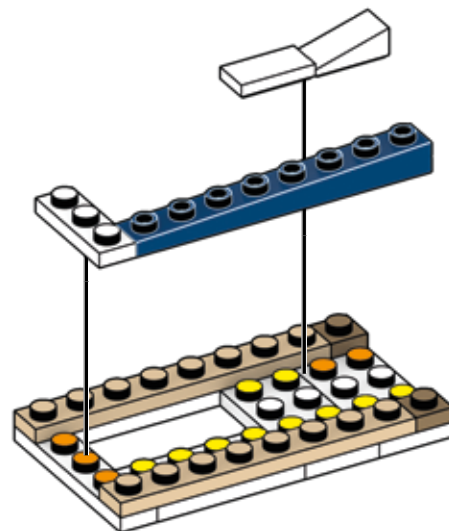
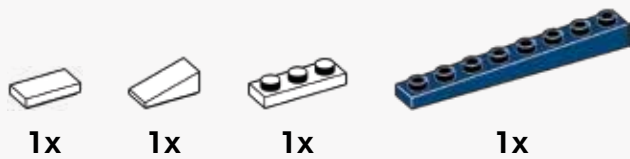

261

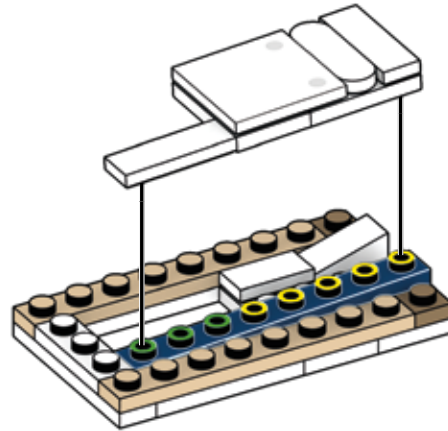
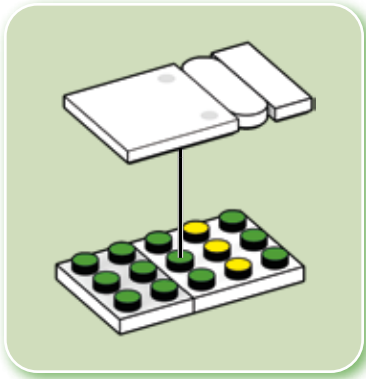
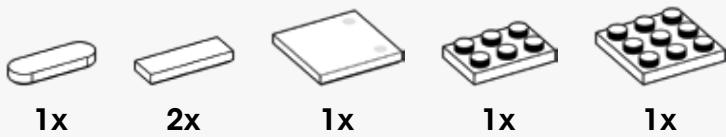

262

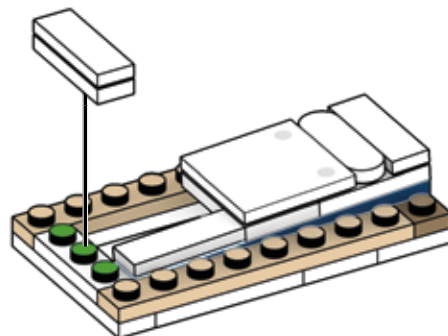
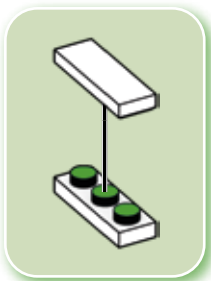

263



1x



1x

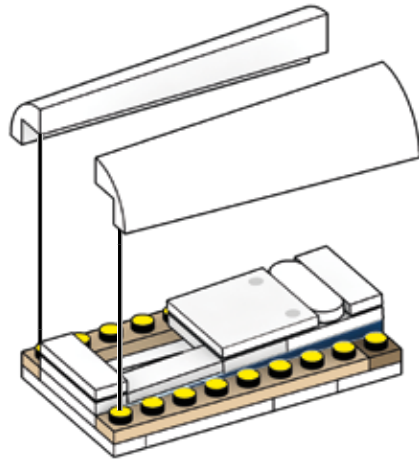

1

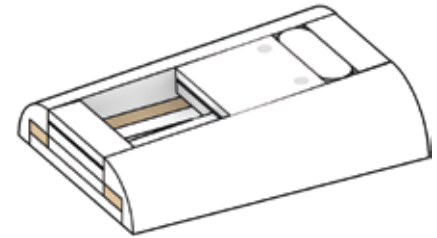

2

264

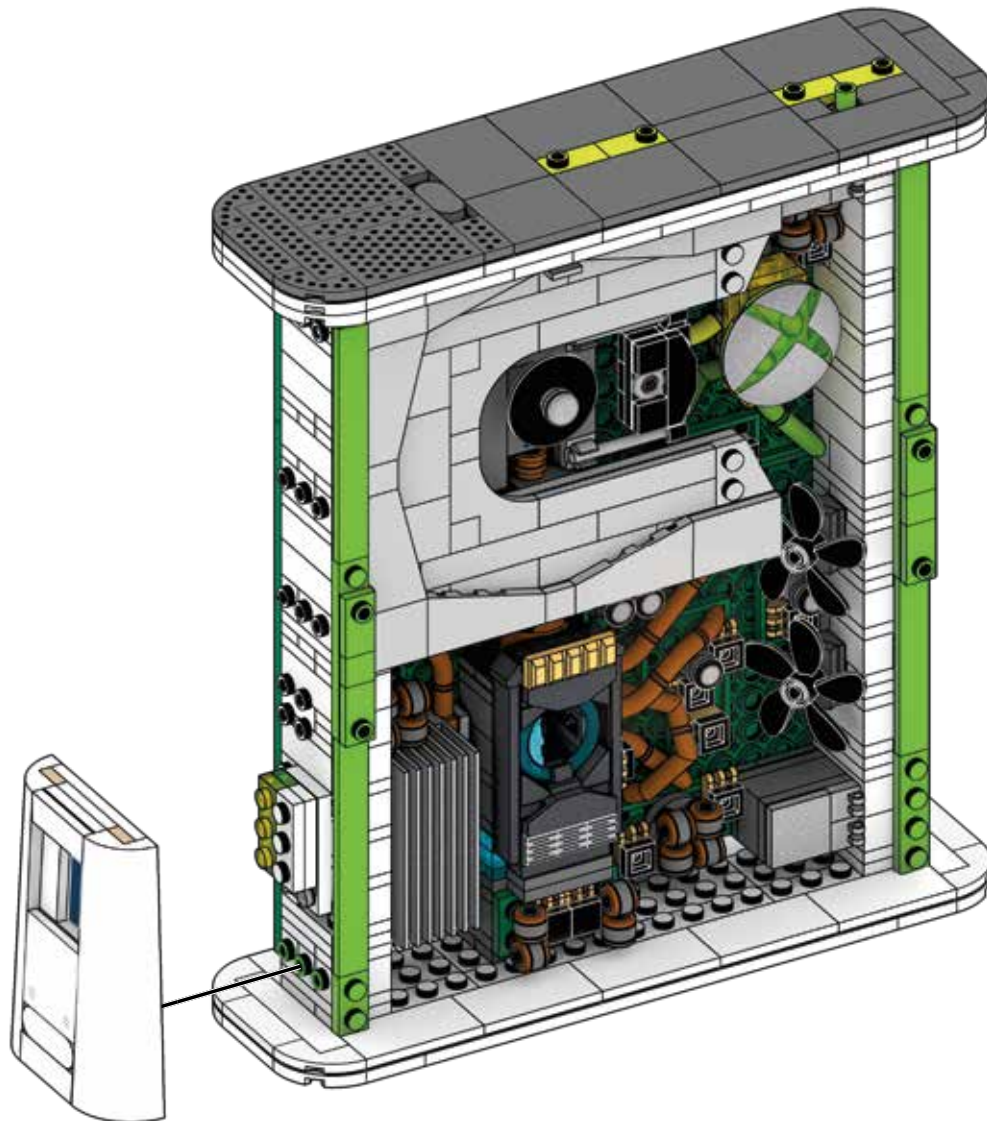

265



1x

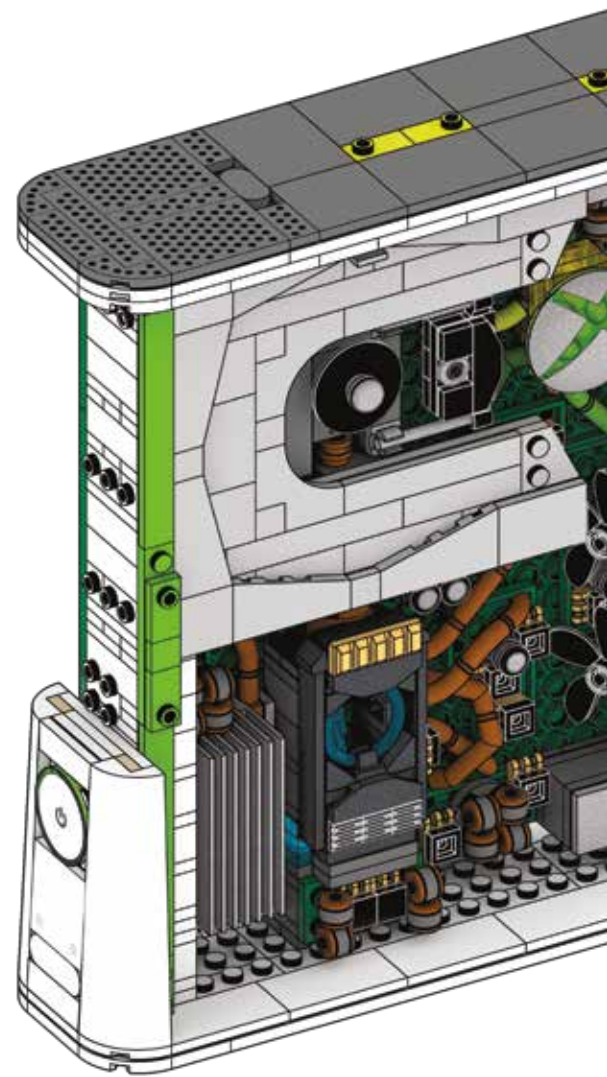
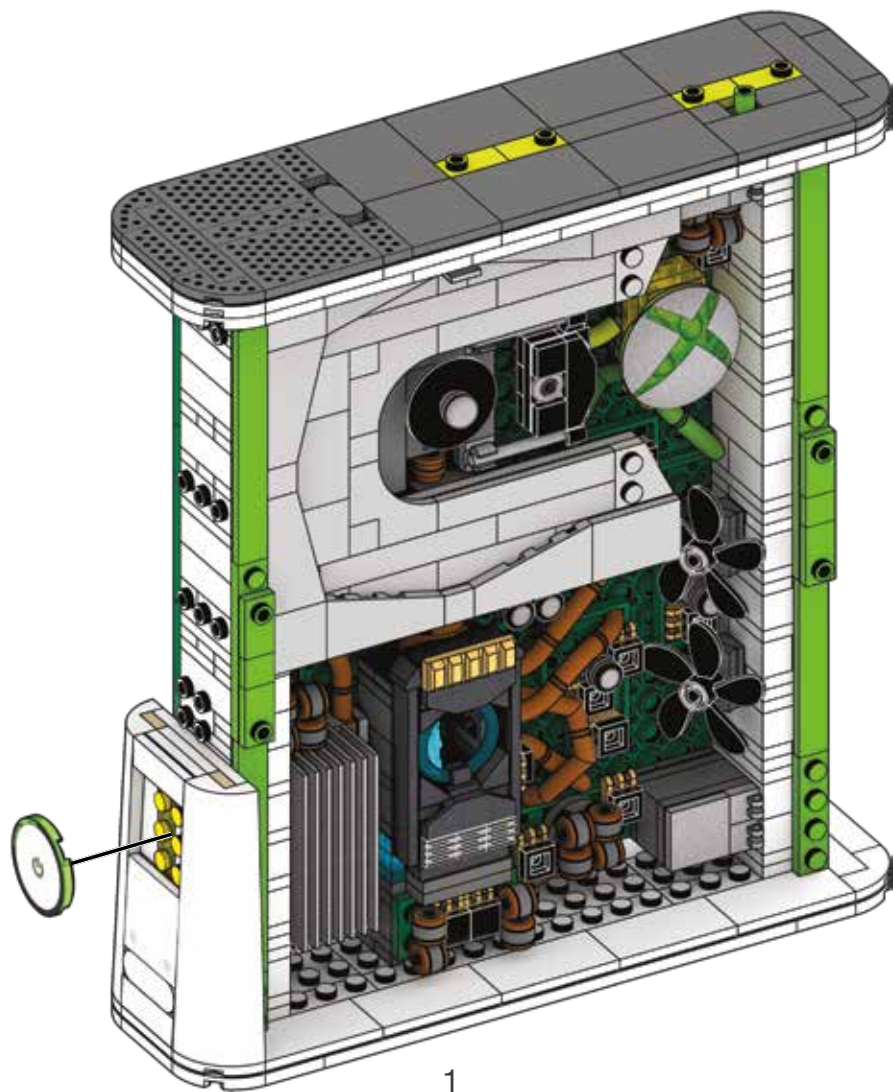

266

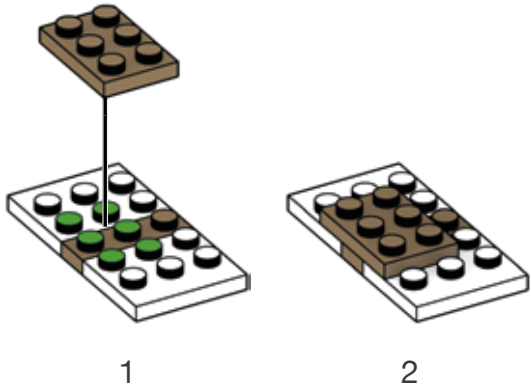

267

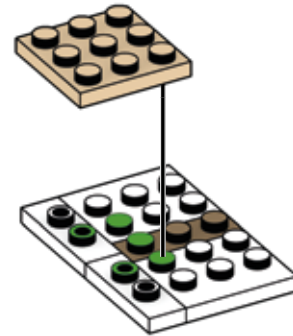

268

269



270

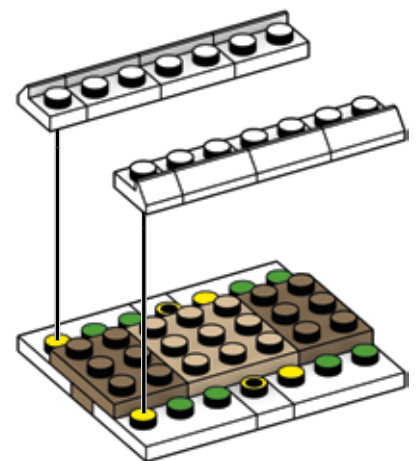
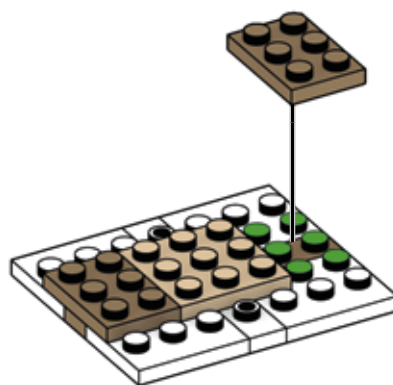
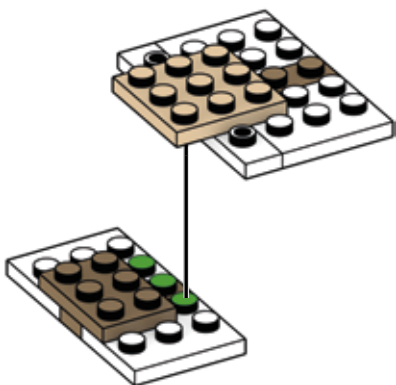
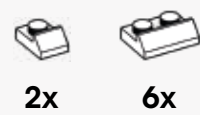

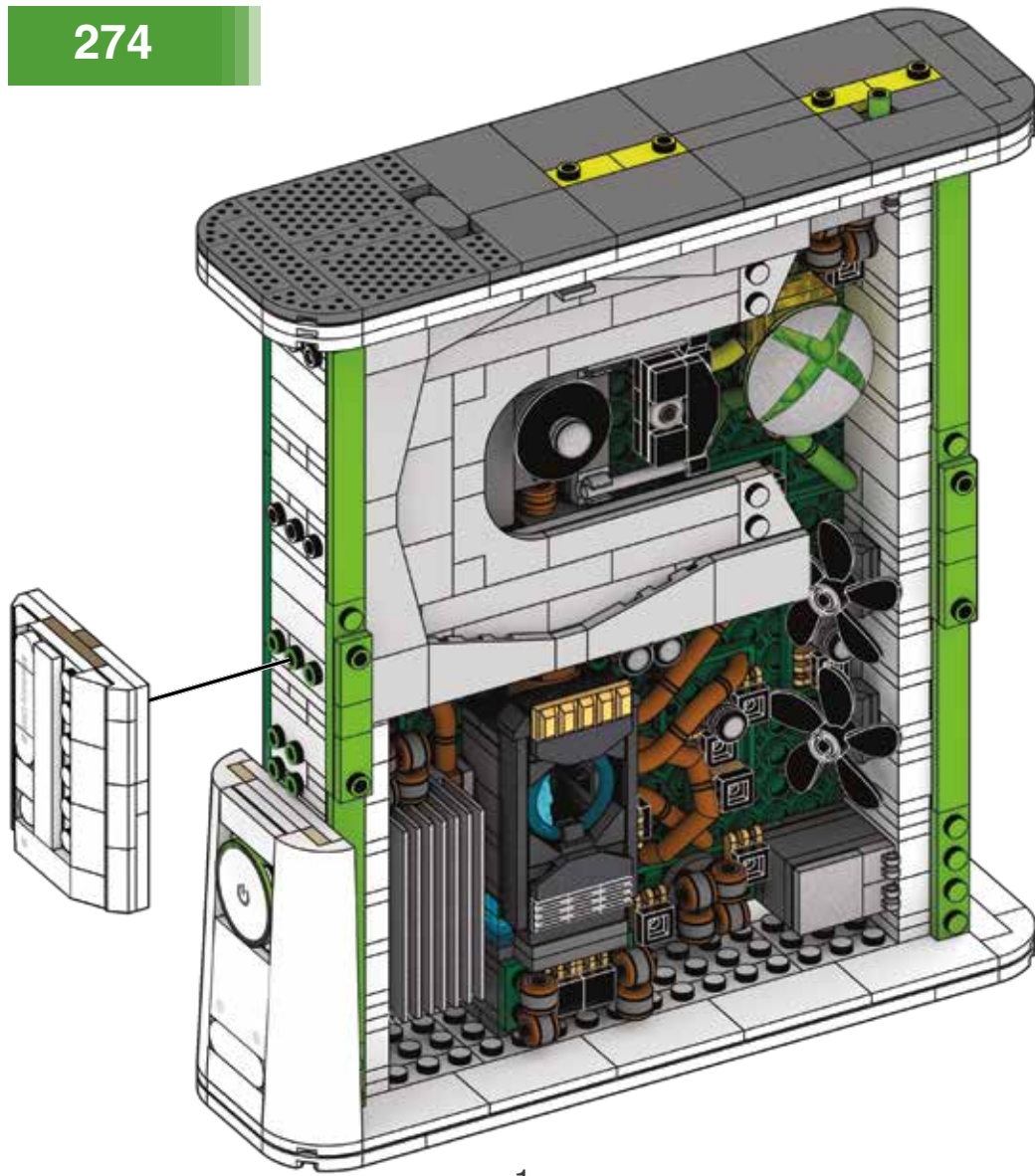

1

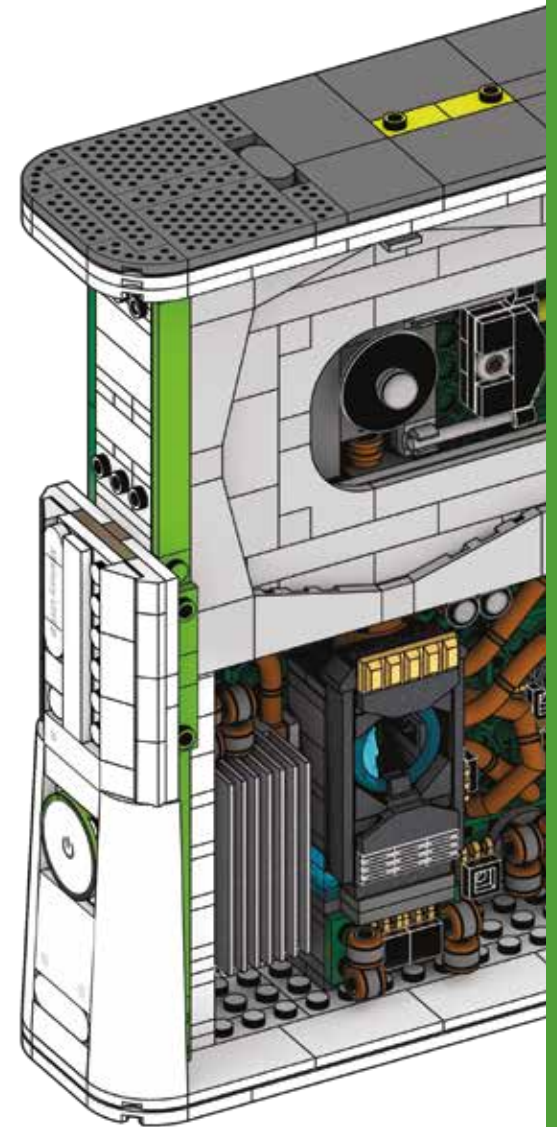

2

275

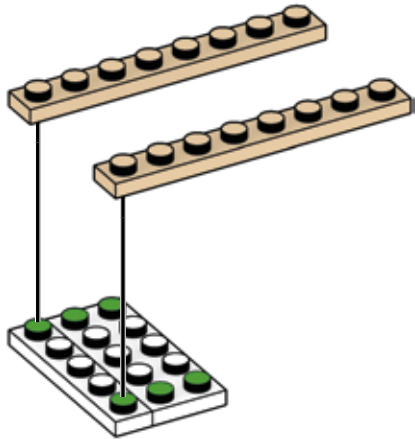
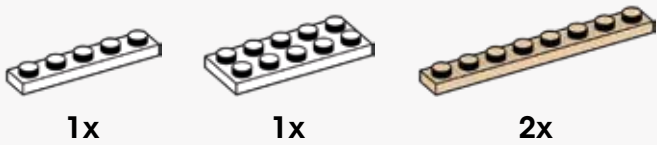

276

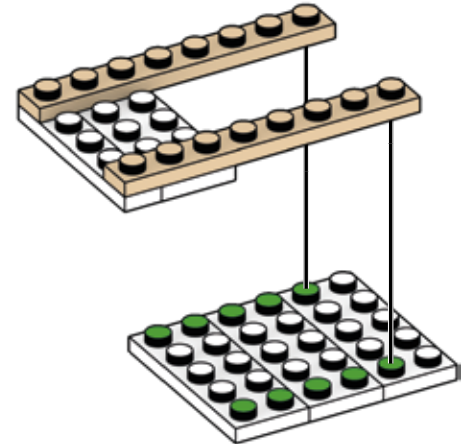
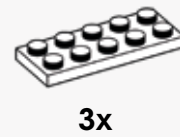

277

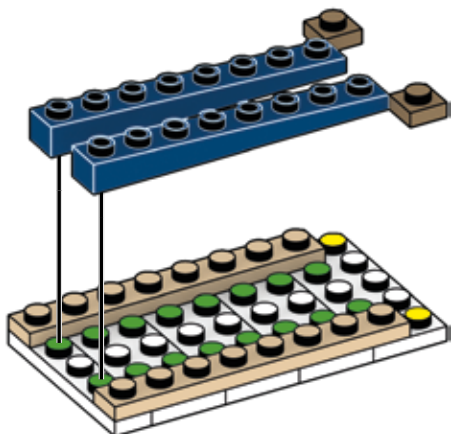

278

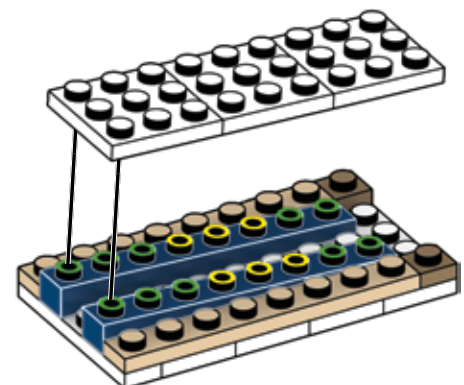
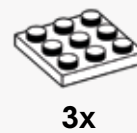

279

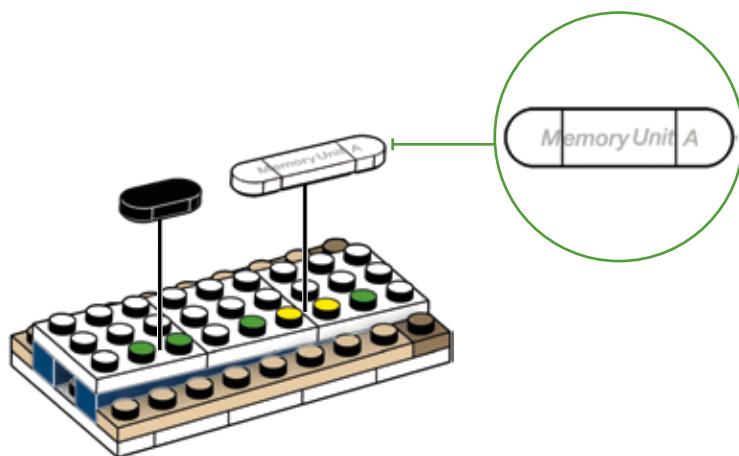

280

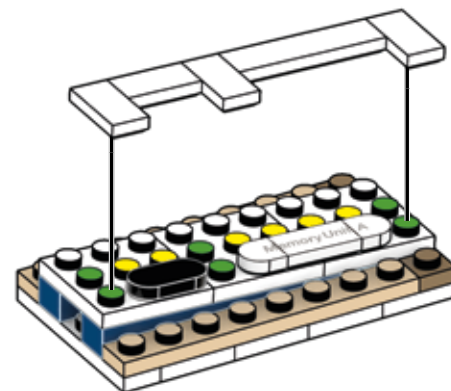
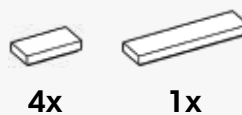

281

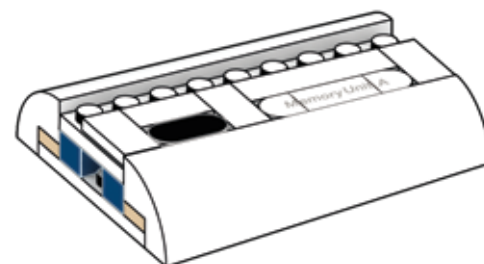
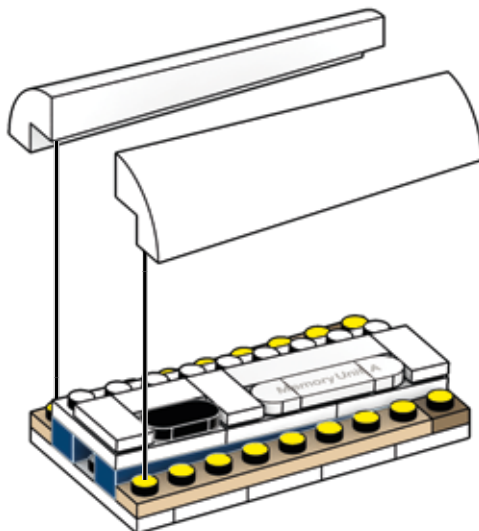

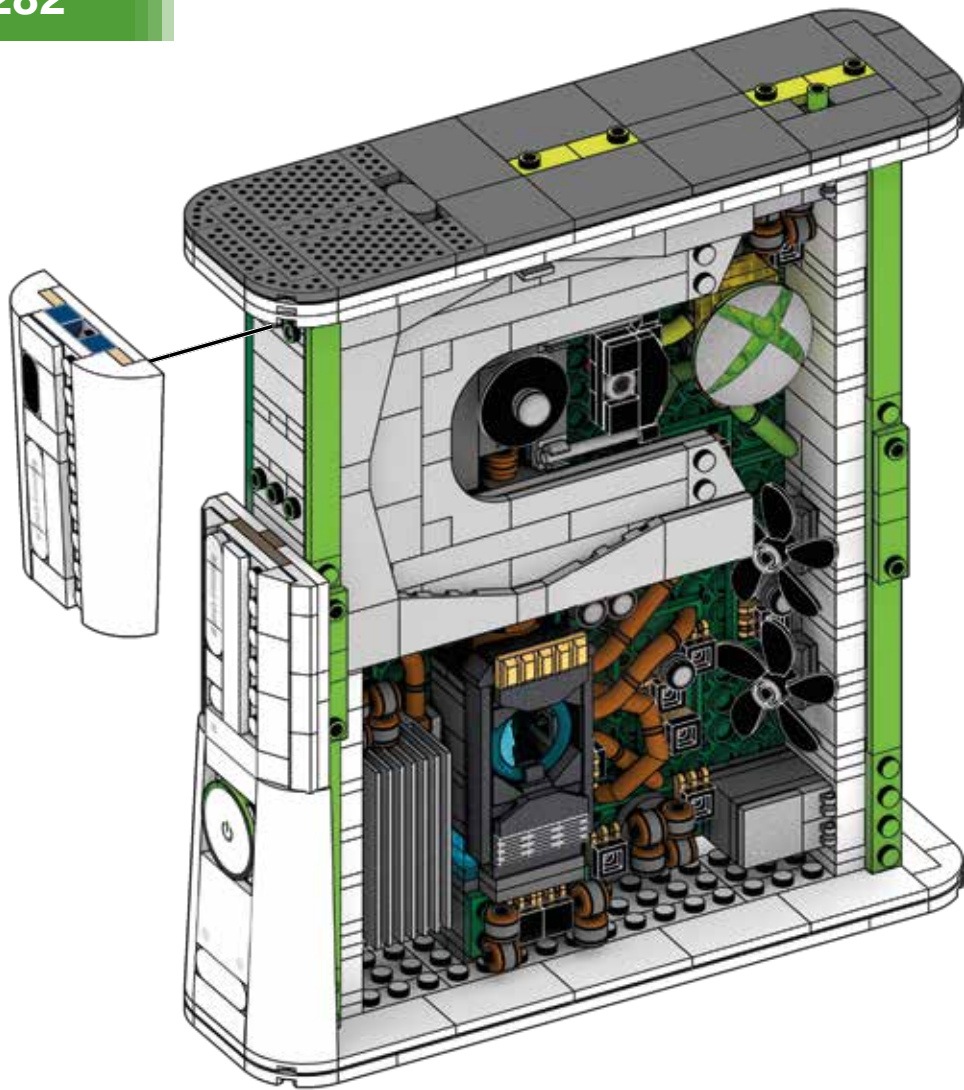

1

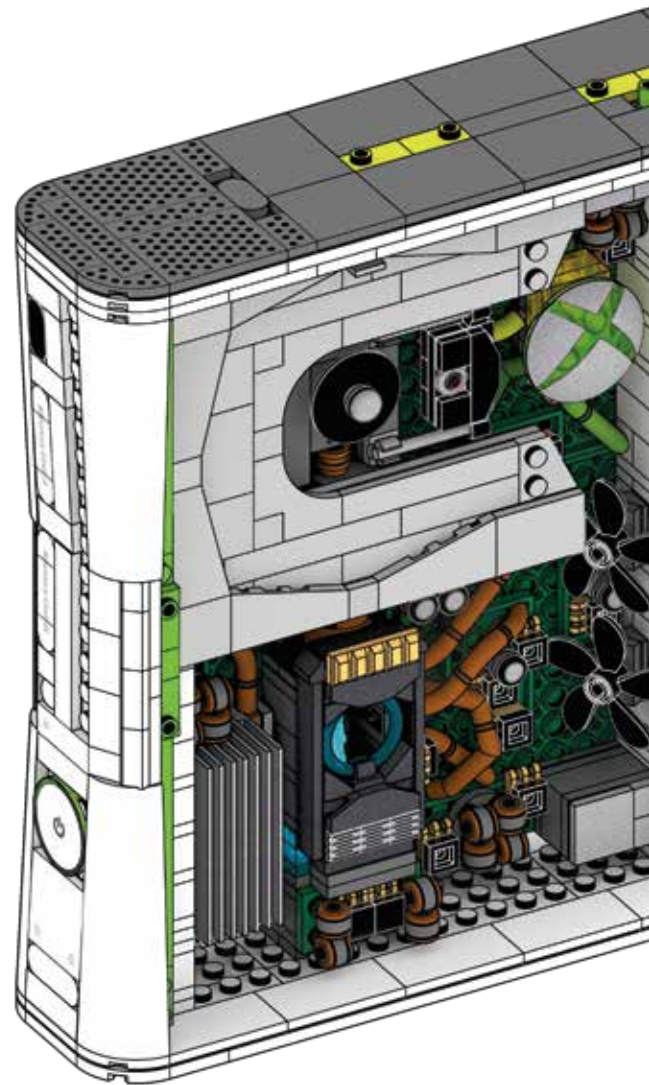

2

283

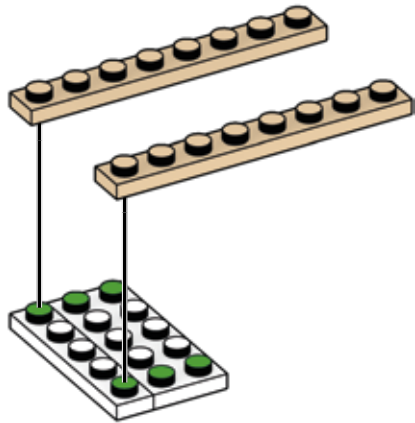
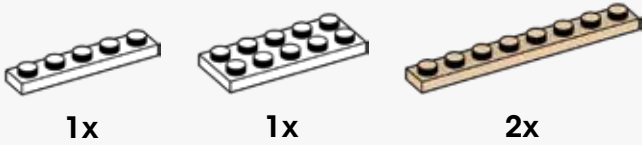

284

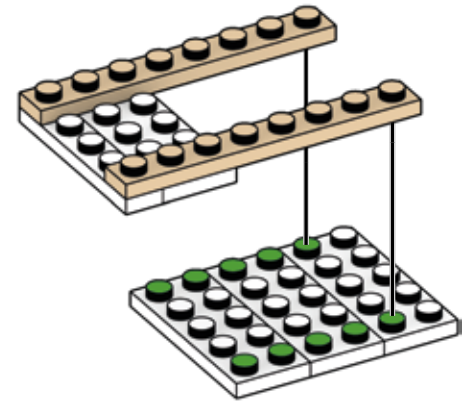
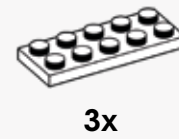

285

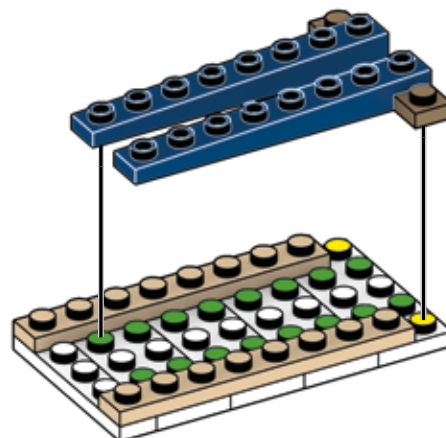

286

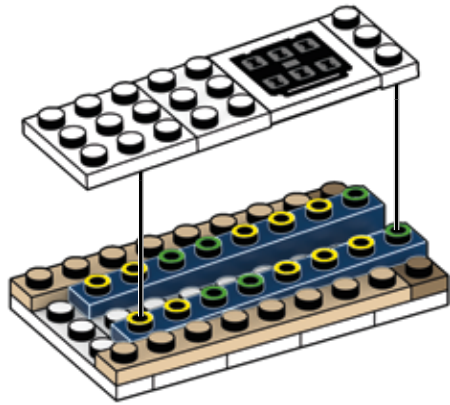
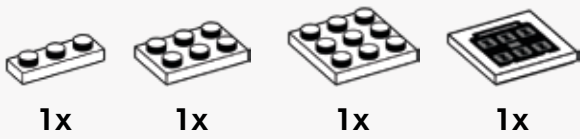

287

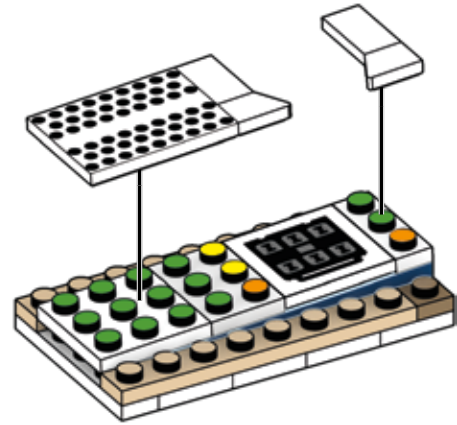
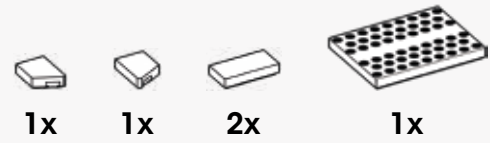

288

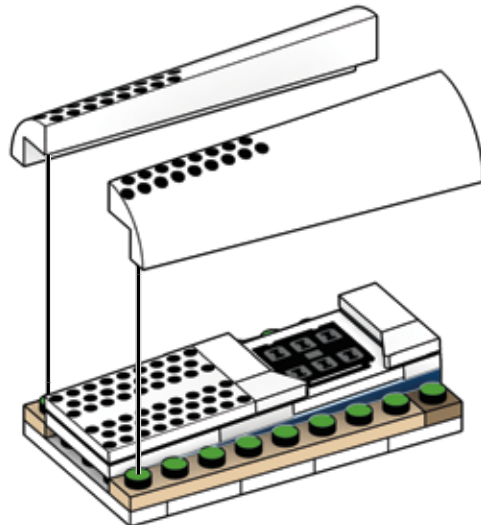
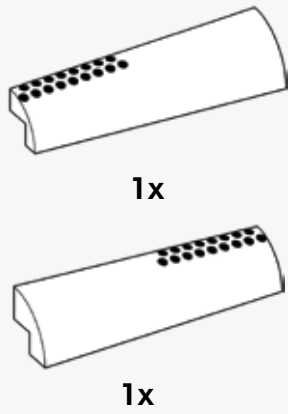

1

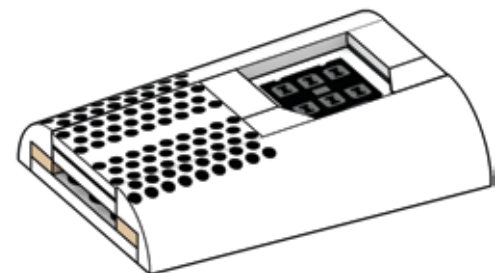

2

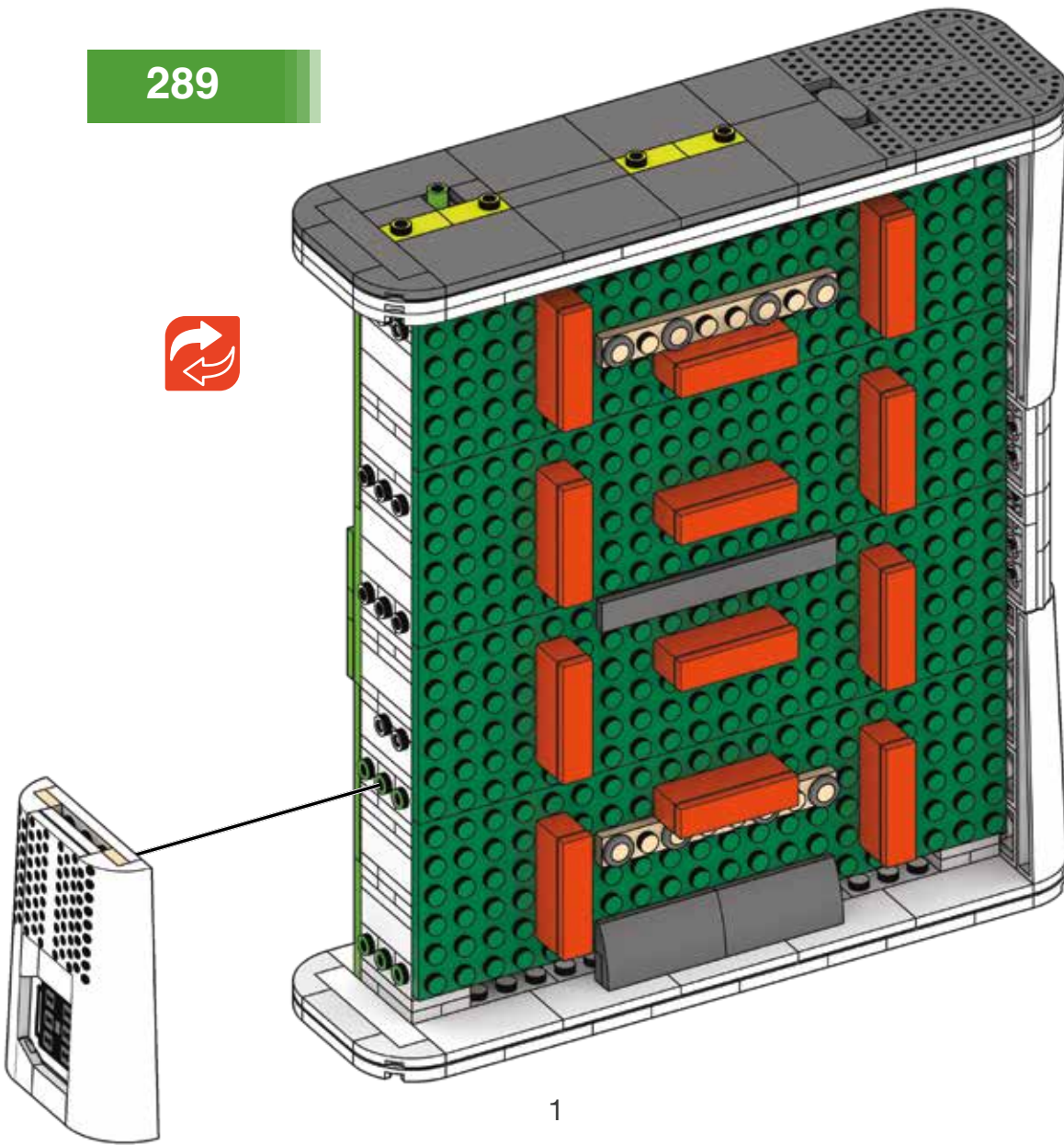

1

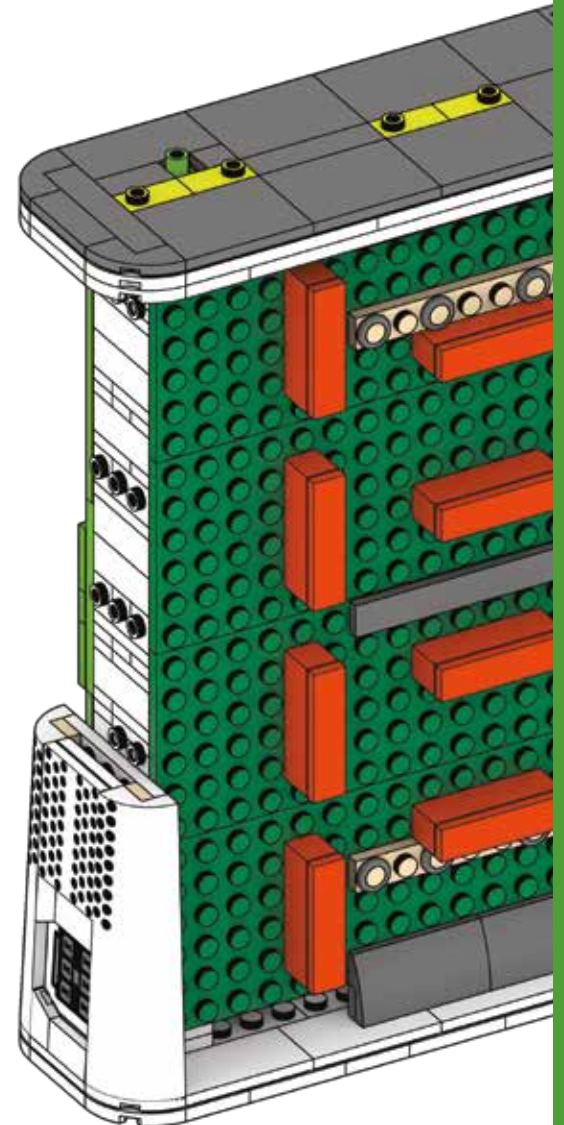

2

290



1x



2x



1x

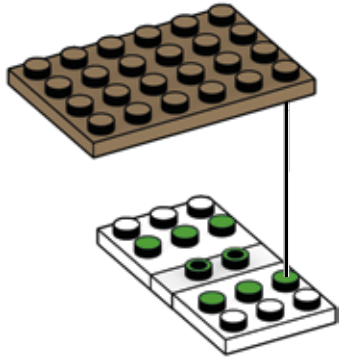

291



2x

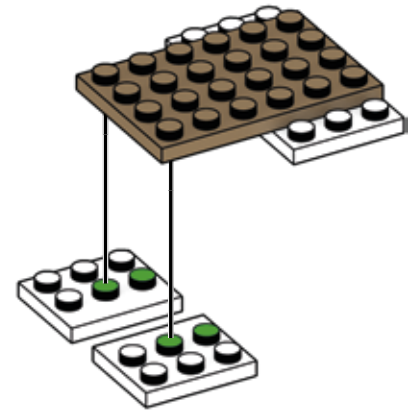

292



1x

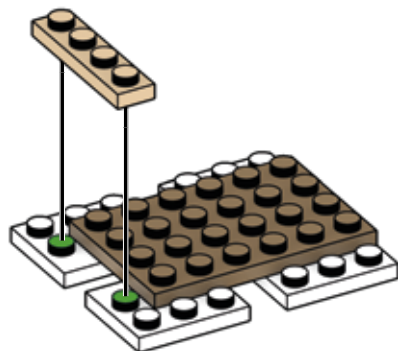

293



1x



1x

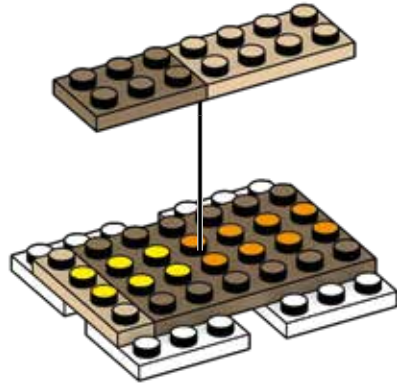

294



1x



1x



2x

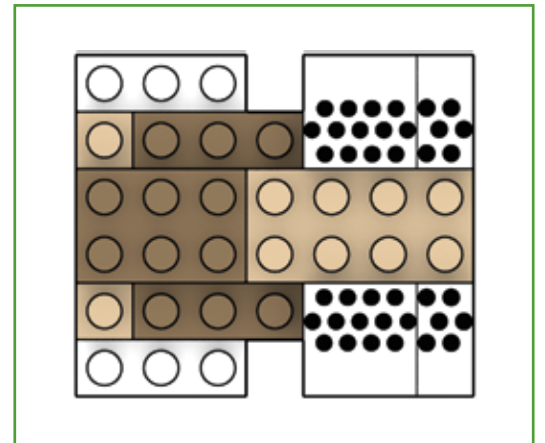
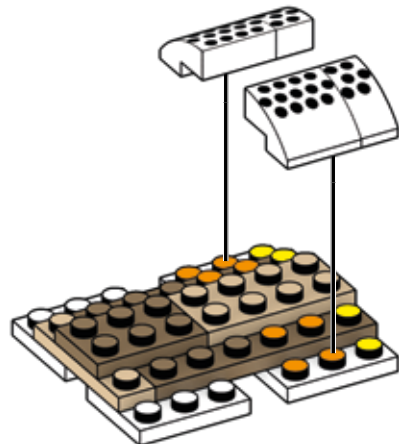

295



2x



2x

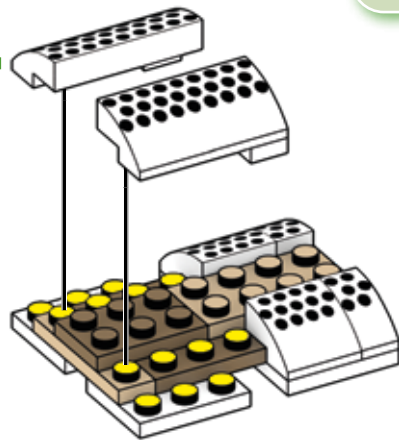
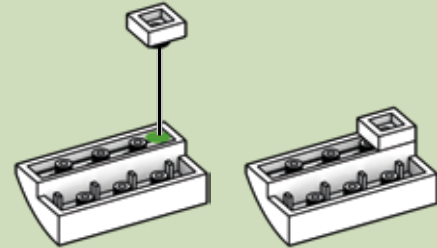
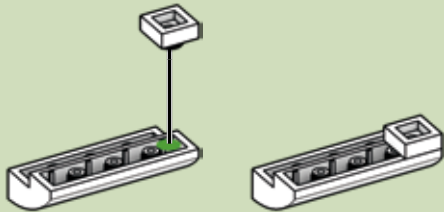

296



1x



1x

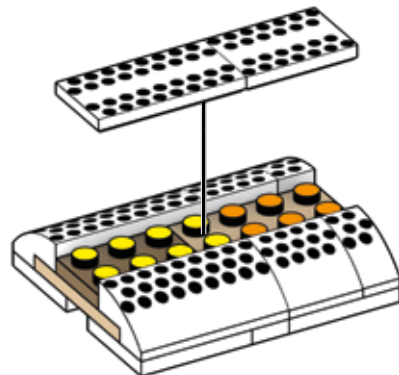

1

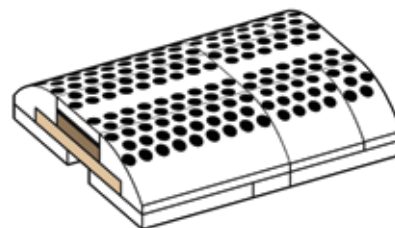

2

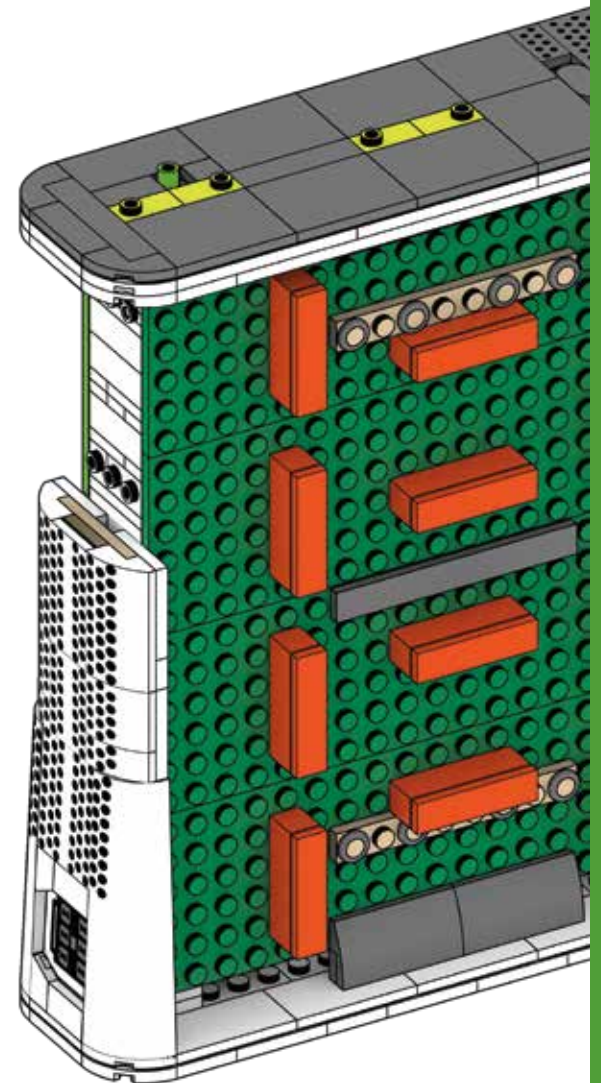
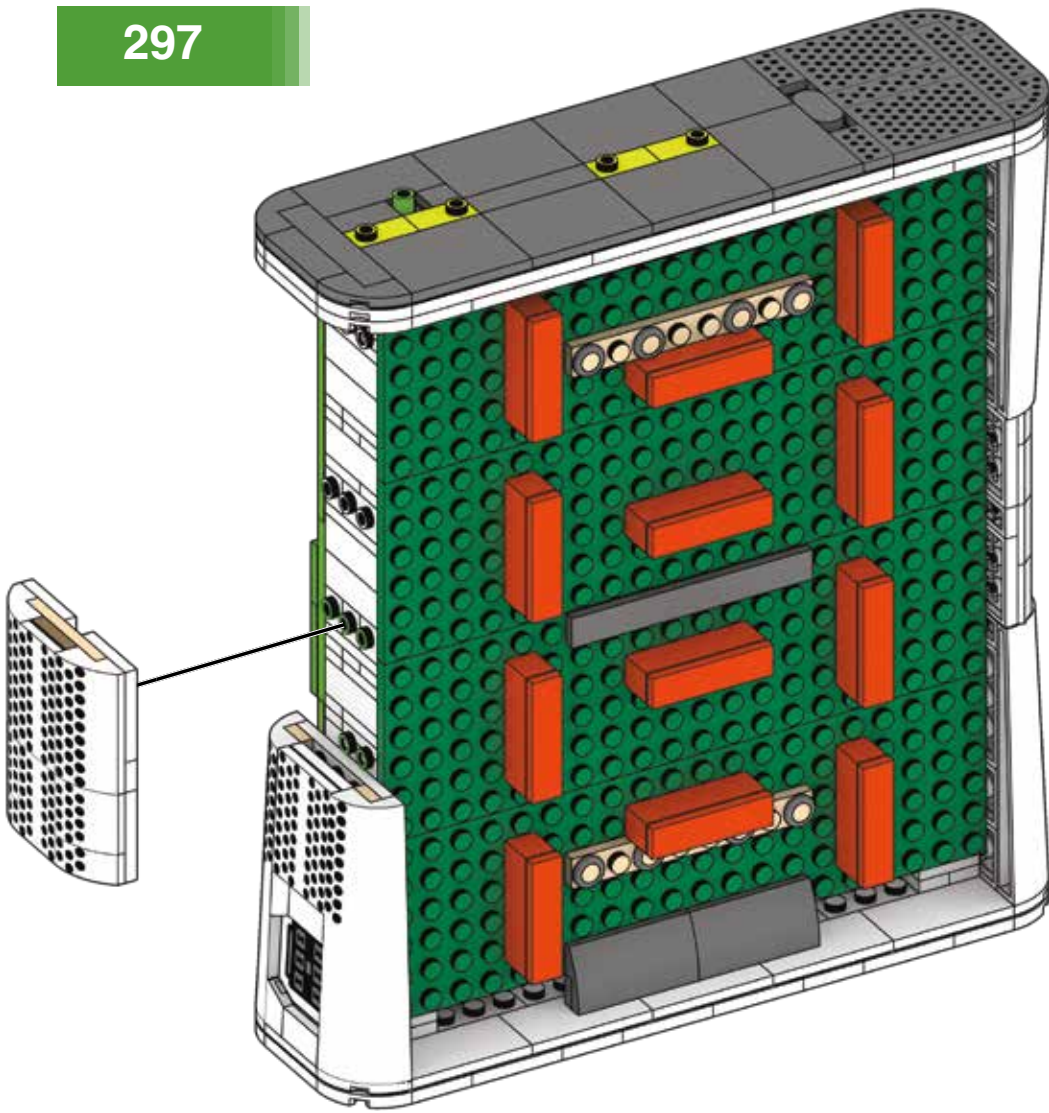

298

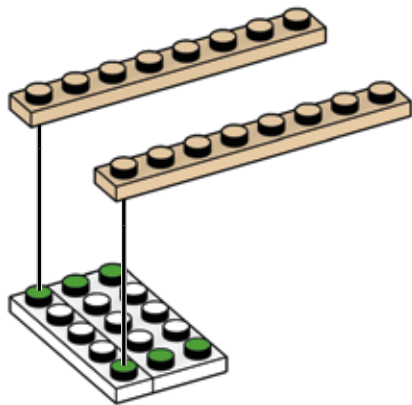
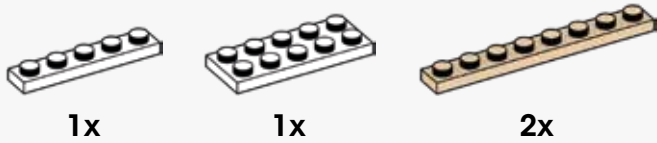

299

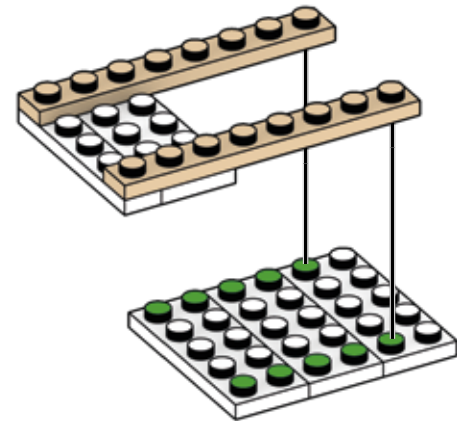
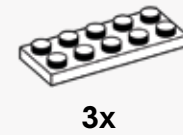

300

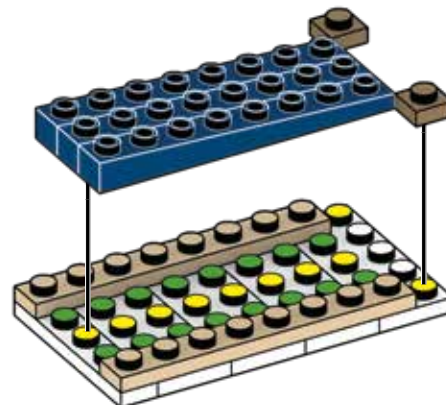

301

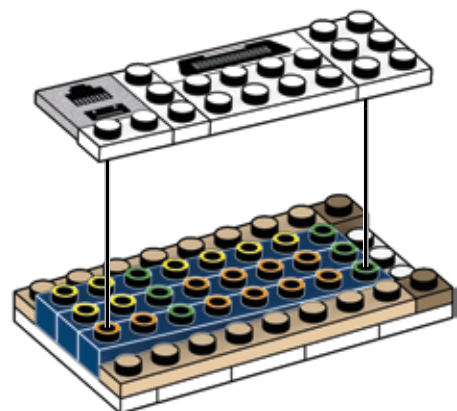
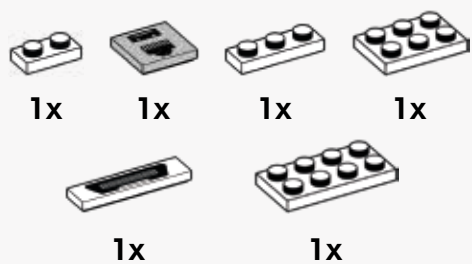

302

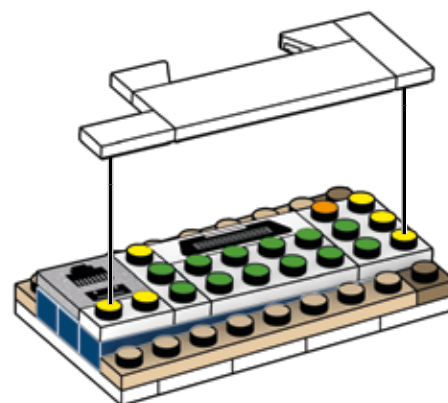
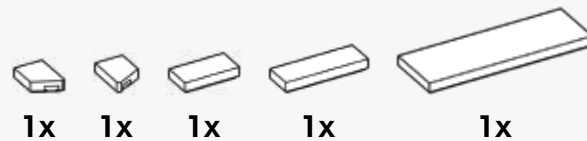

303

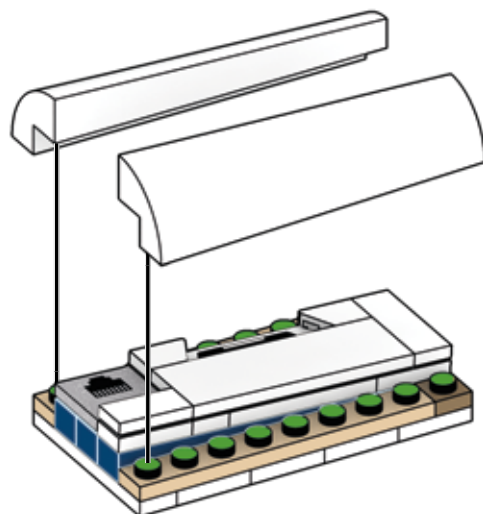
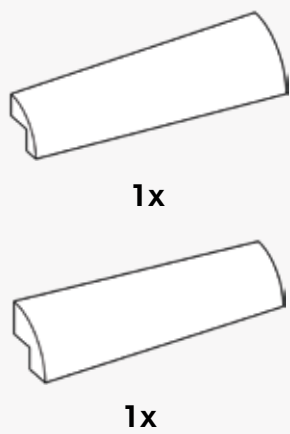

1

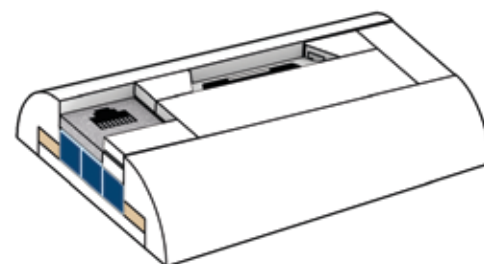

2

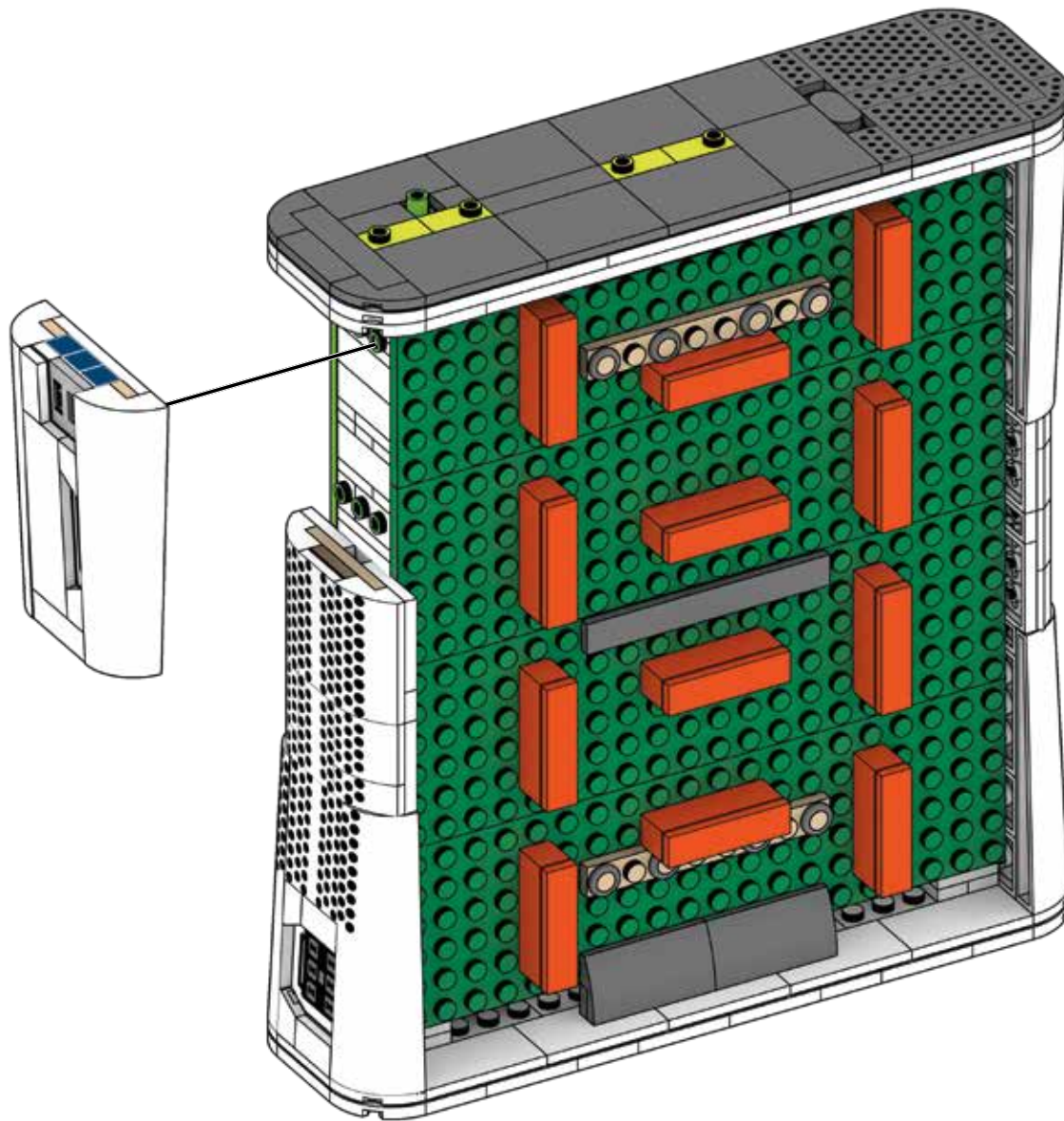

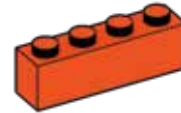
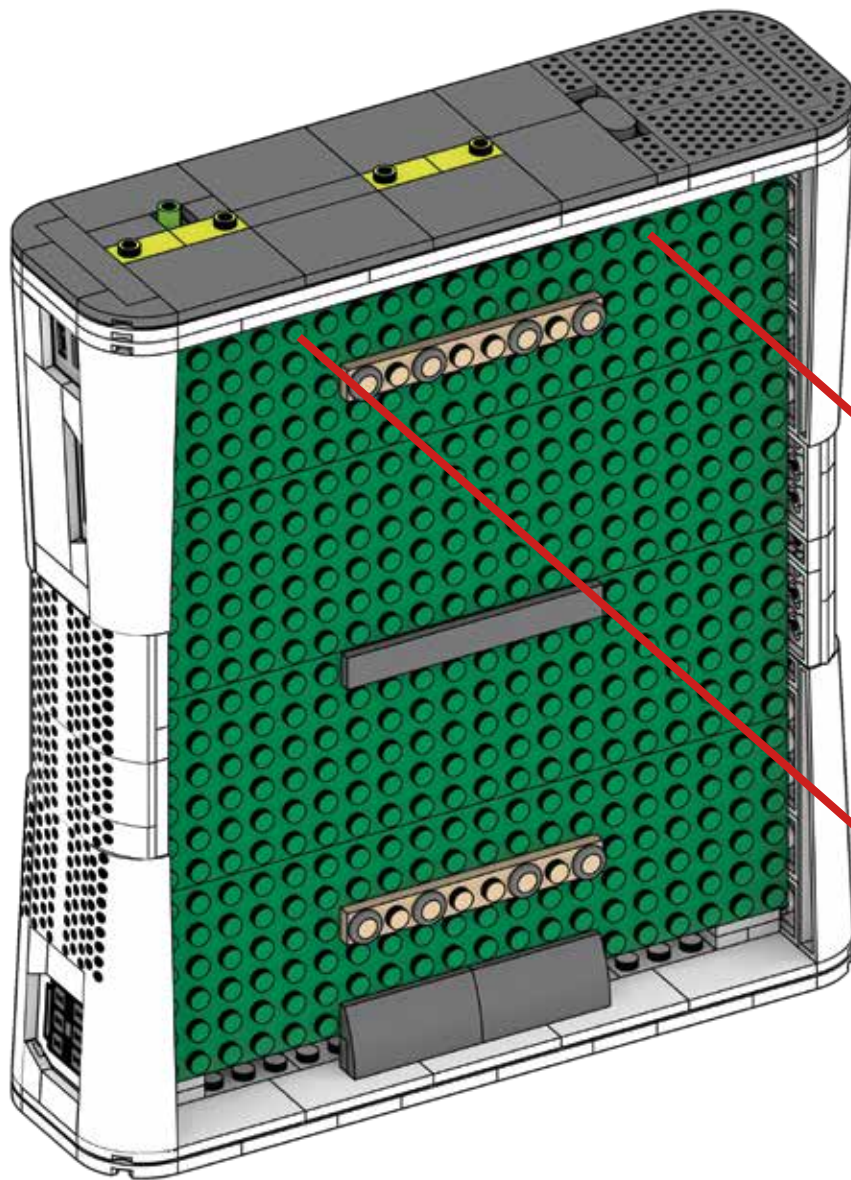

Remove temporary pieces.
Retirer les pièces temporaires.

Retirar las piezas provisionales.

Remover as peças temporárias.

Rimuovere i pezzi provvisori.

Die vorübergehend benötigten Teile entfernen.

Usunąć elementy tymczasowe.

Verwijder tijdelijke delen.

Удалите временные детали.

Fjern midlertidige stykker.

Ta bort temporära delar.

Fjern midlertidige deler.

Poista väliaikaiset osat.

Αφαιρέστε τα προσωρινά κομμάτια.

Geçici parçaları çıkarın.

Odstraňte dočasné diely.

Vyberte dočasné kusy.

Távolítsa el az ideiglenes darabokat.

暫定ピースを外してください

انزع القطع المؤقتة.

移除临时件

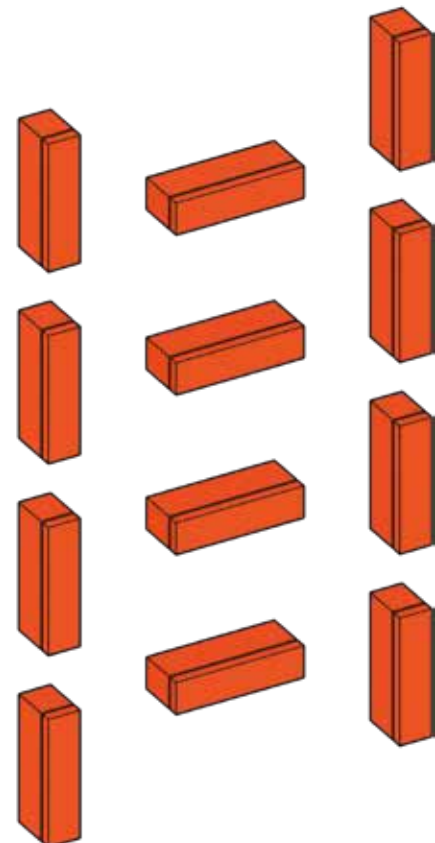

306



4x

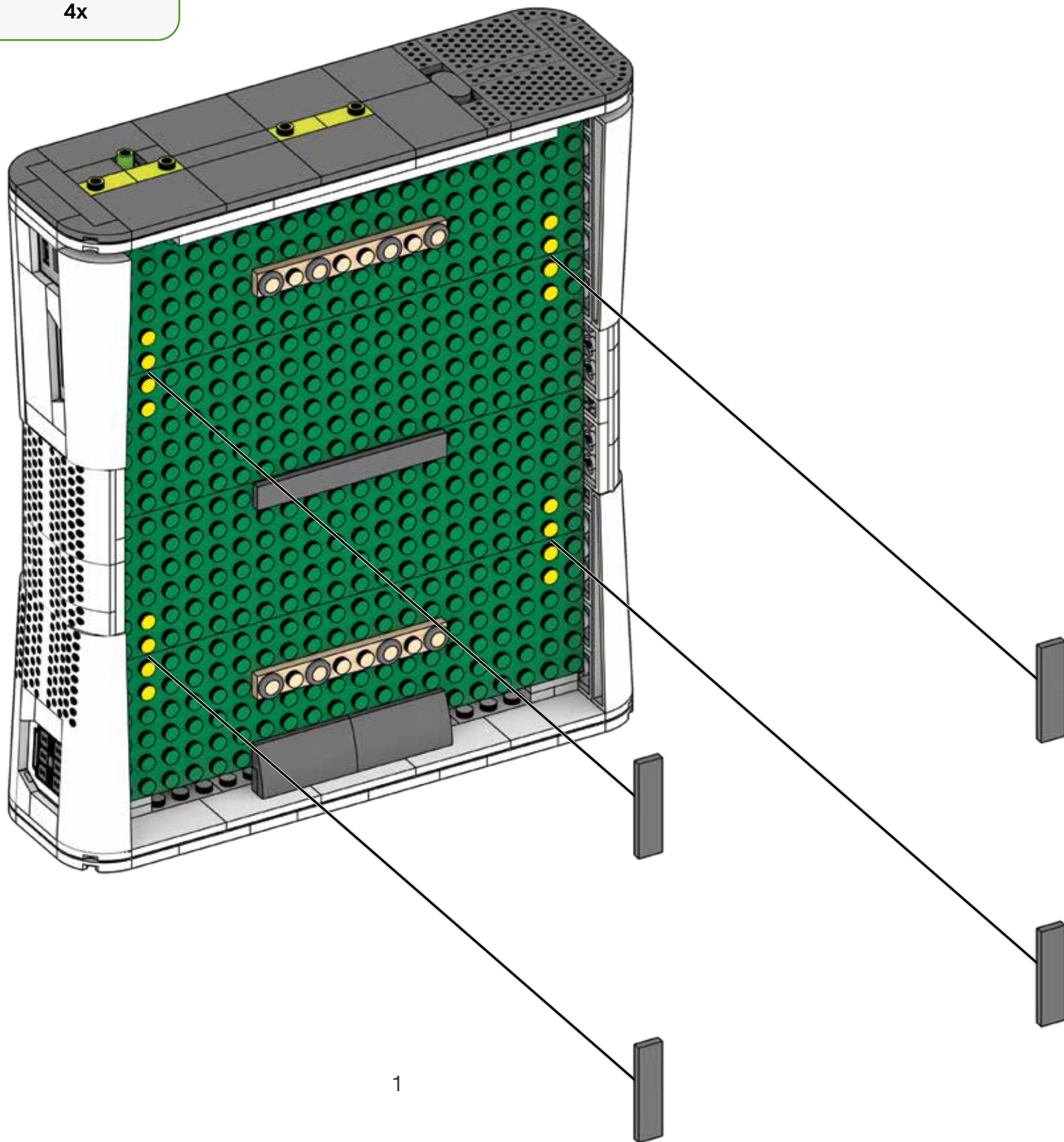

1

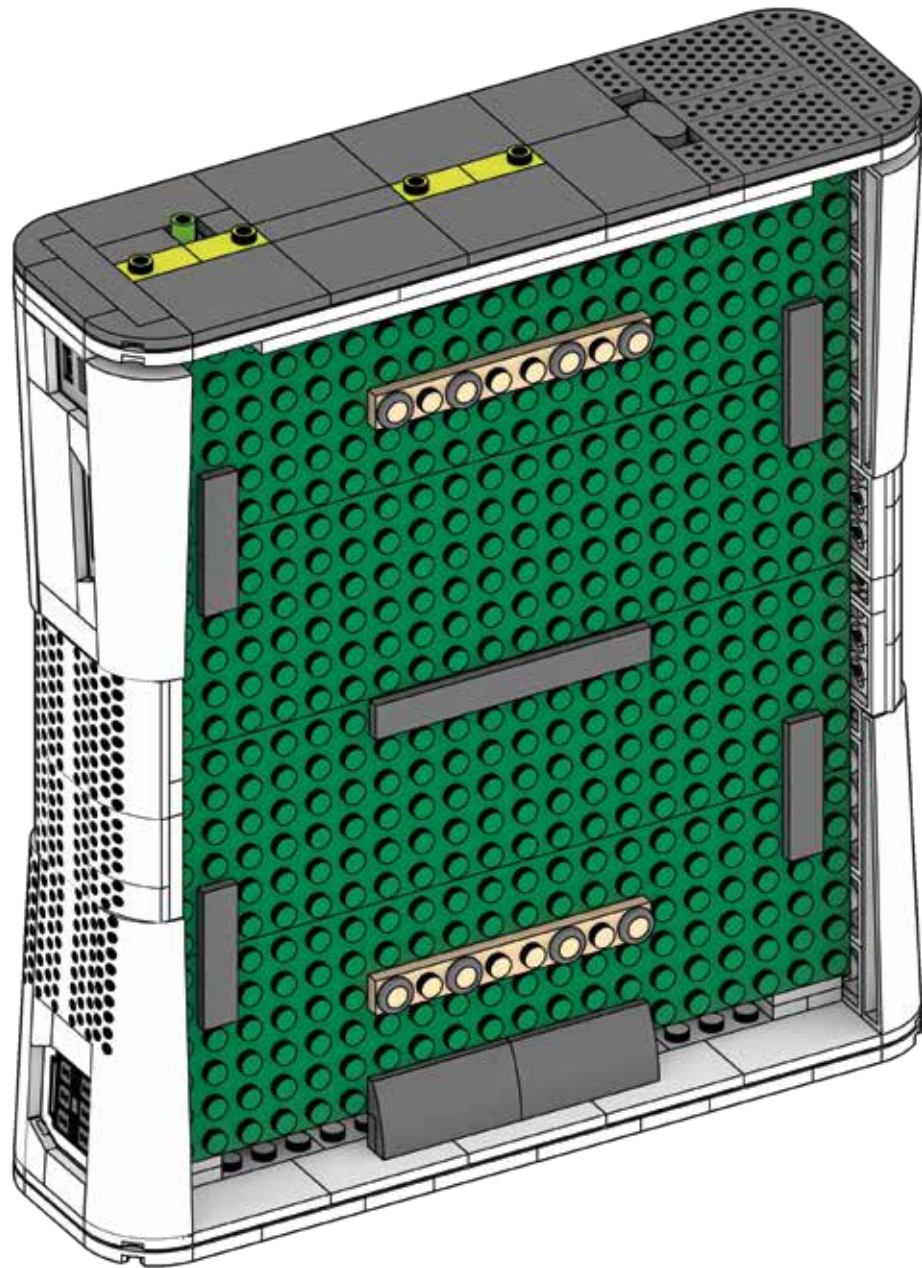

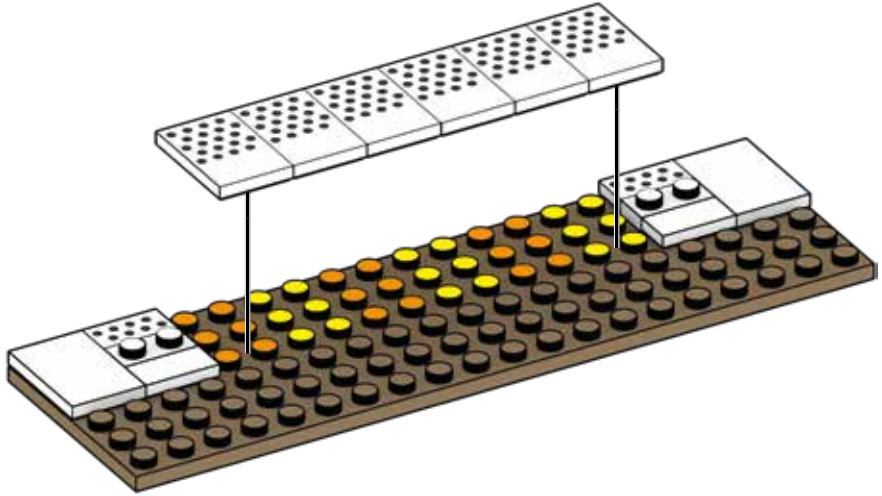
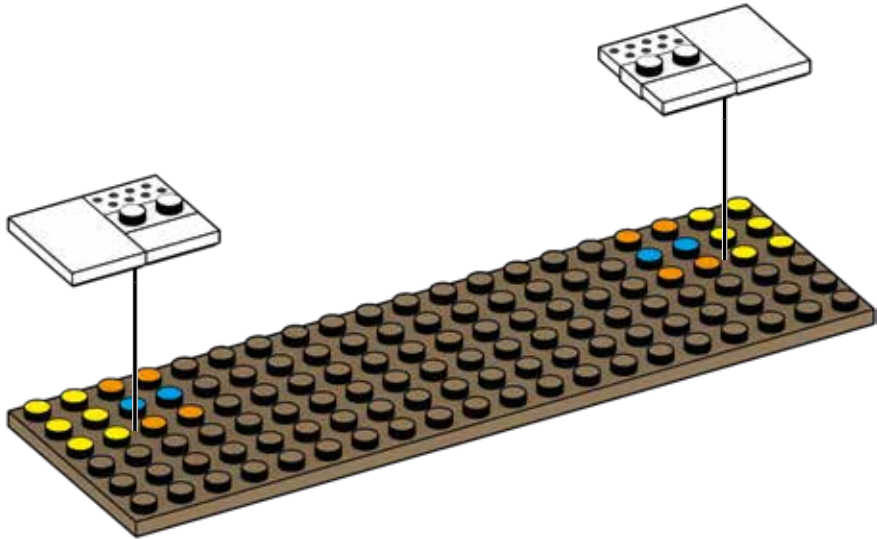
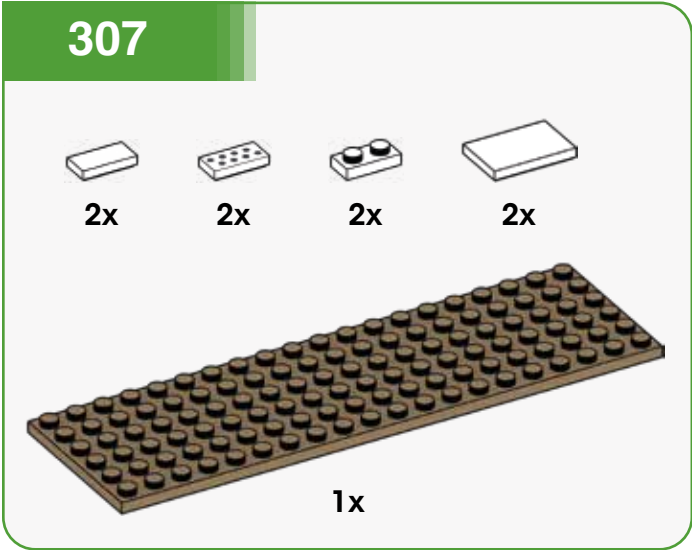
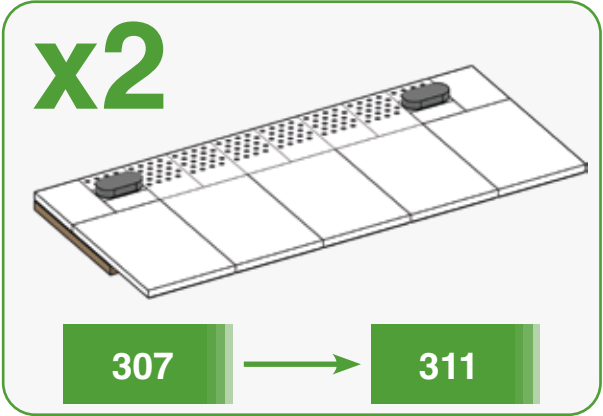

309

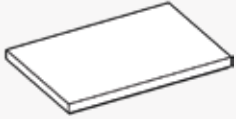

5x

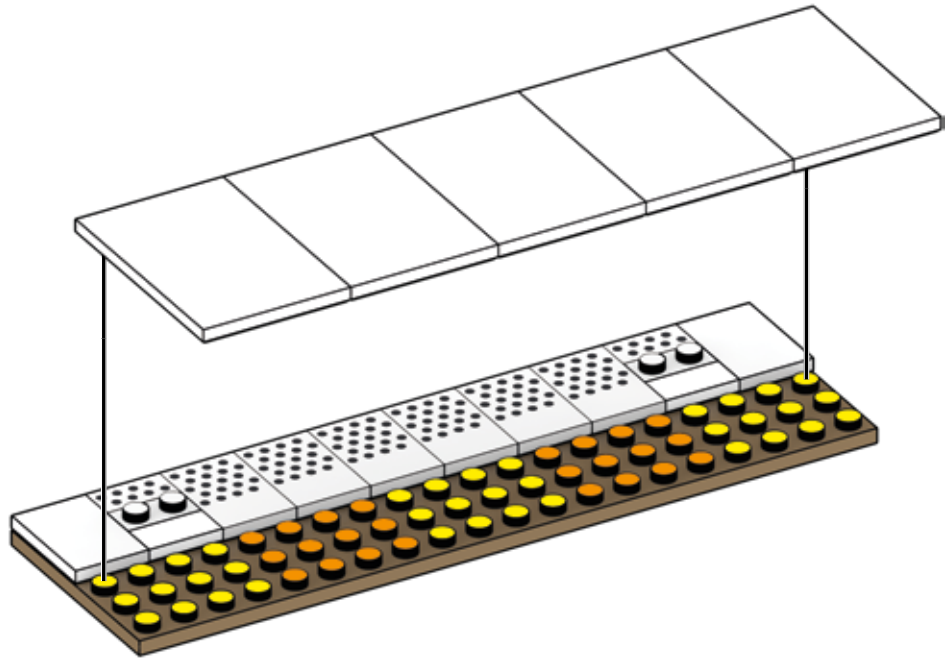

310



2x

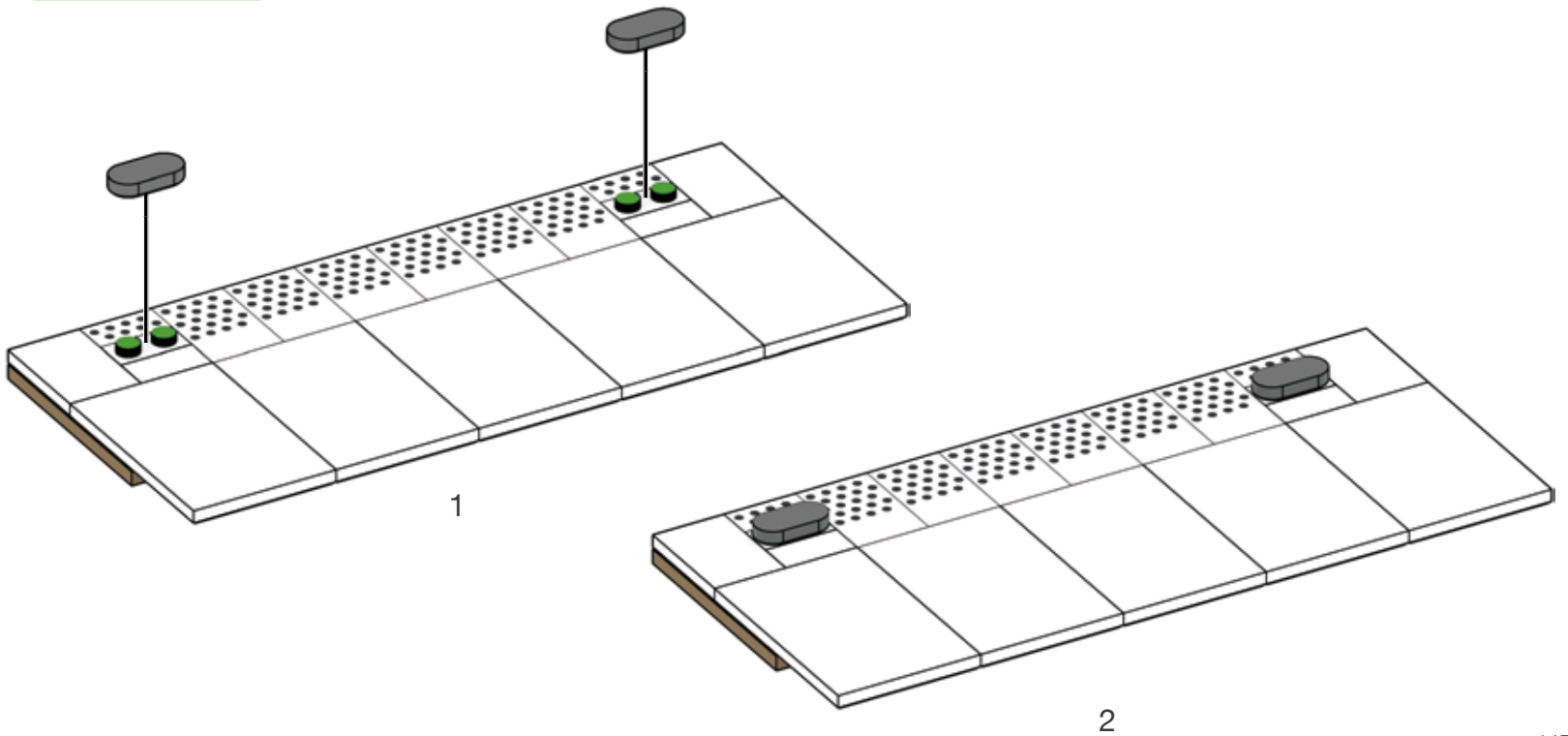

311



2x



2x



2x



1



2

x2

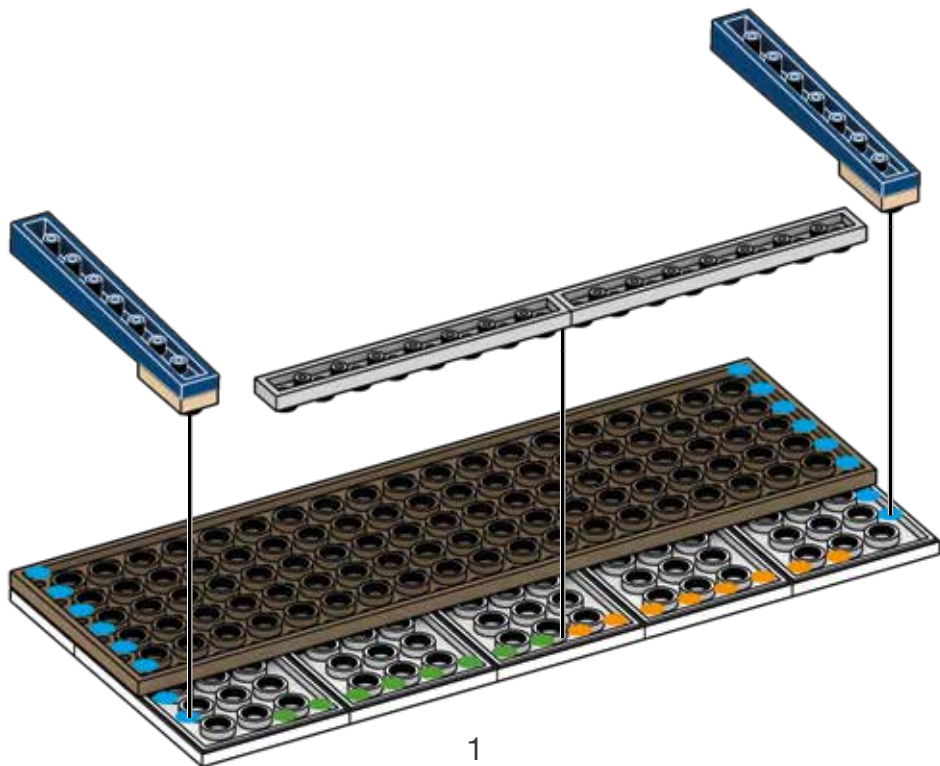

1

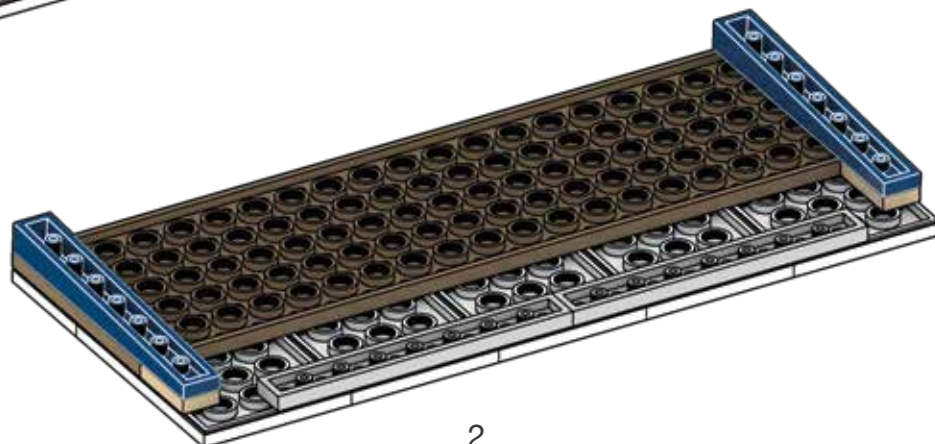

2

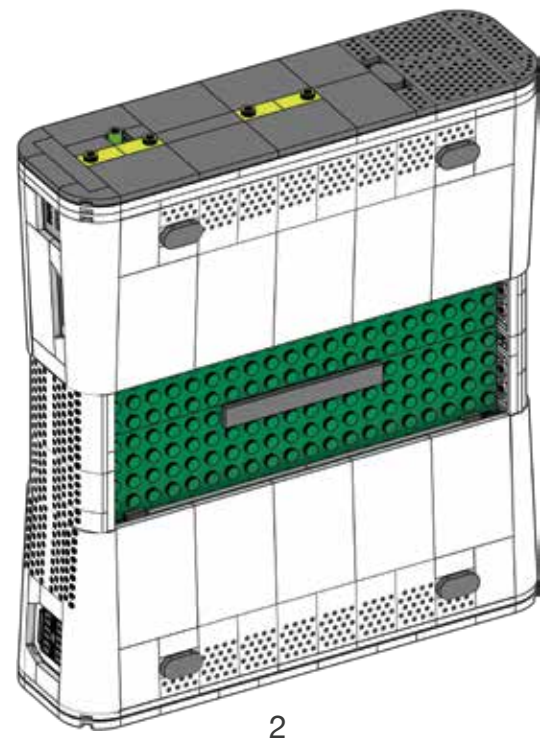
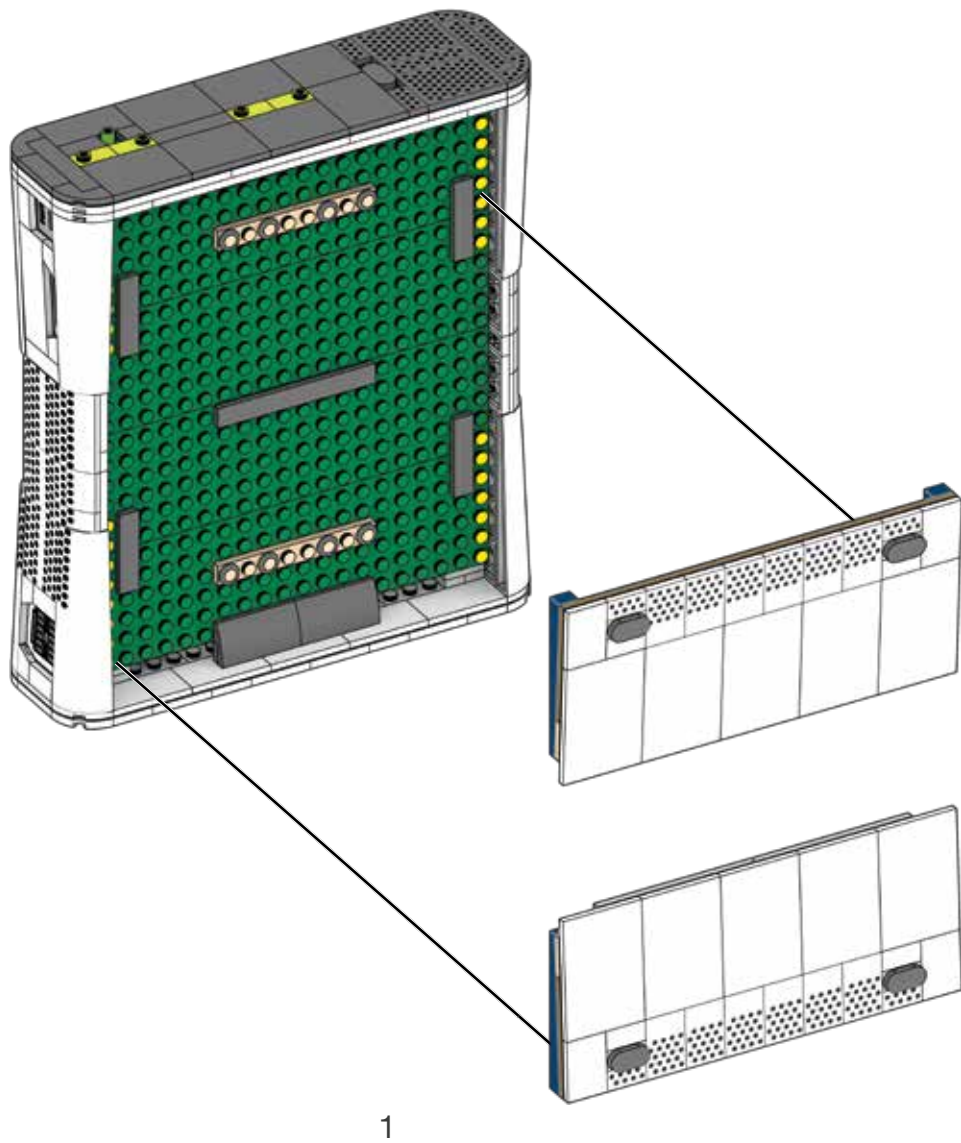

313



1x



1x



2x

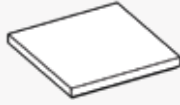

2x

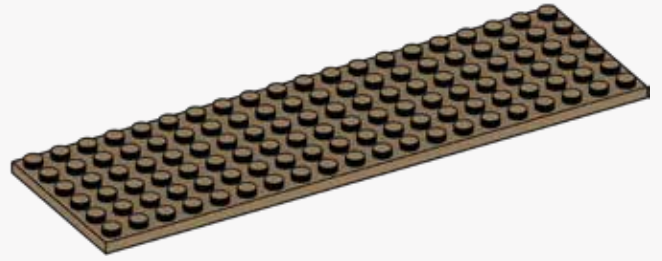

1x

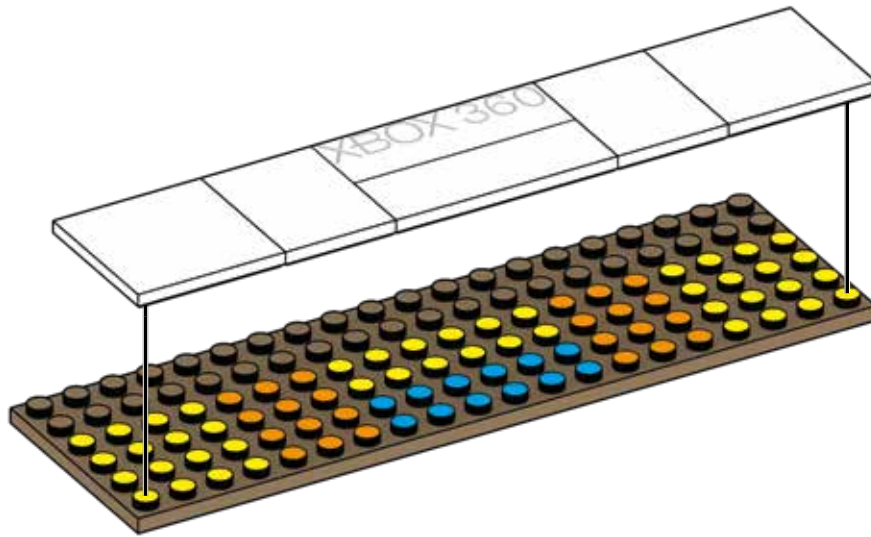

314

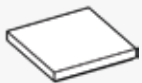

4x



2x

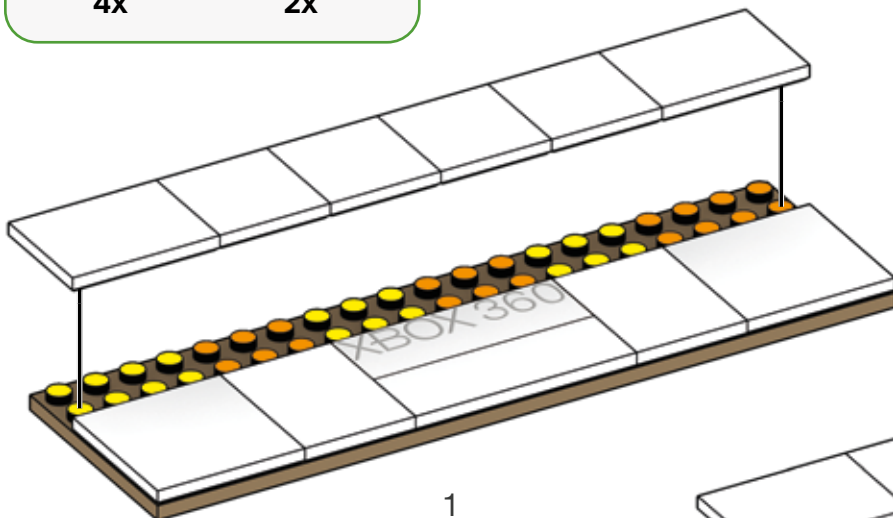

1

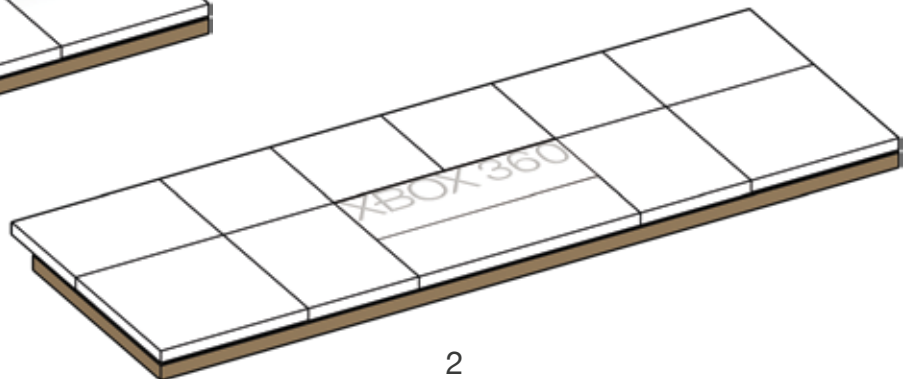

2

315



2x

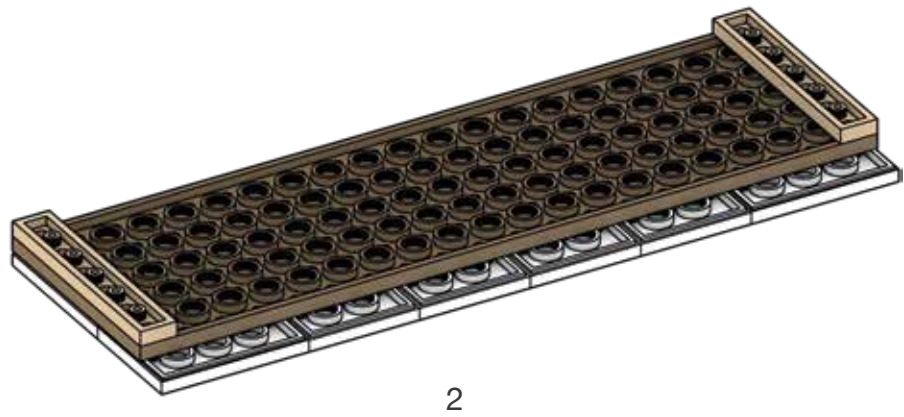
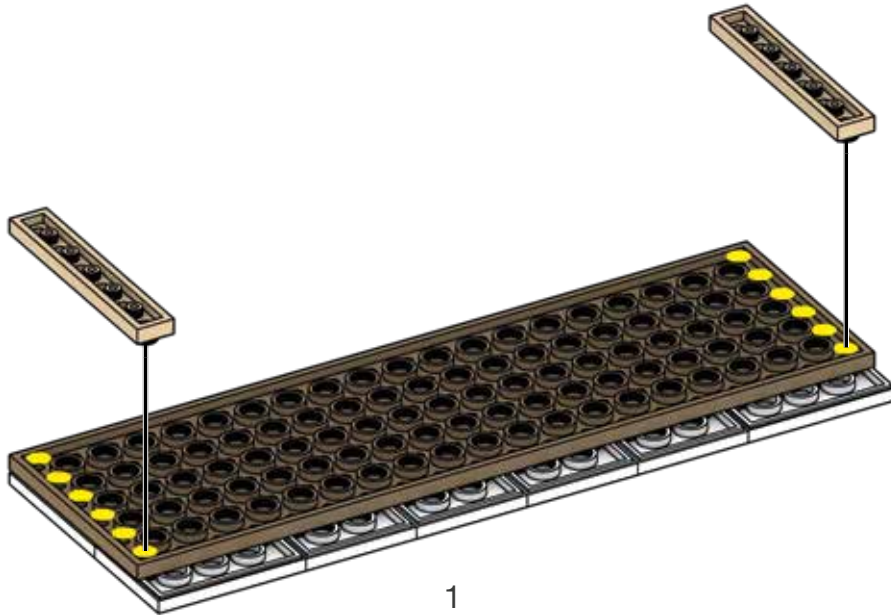

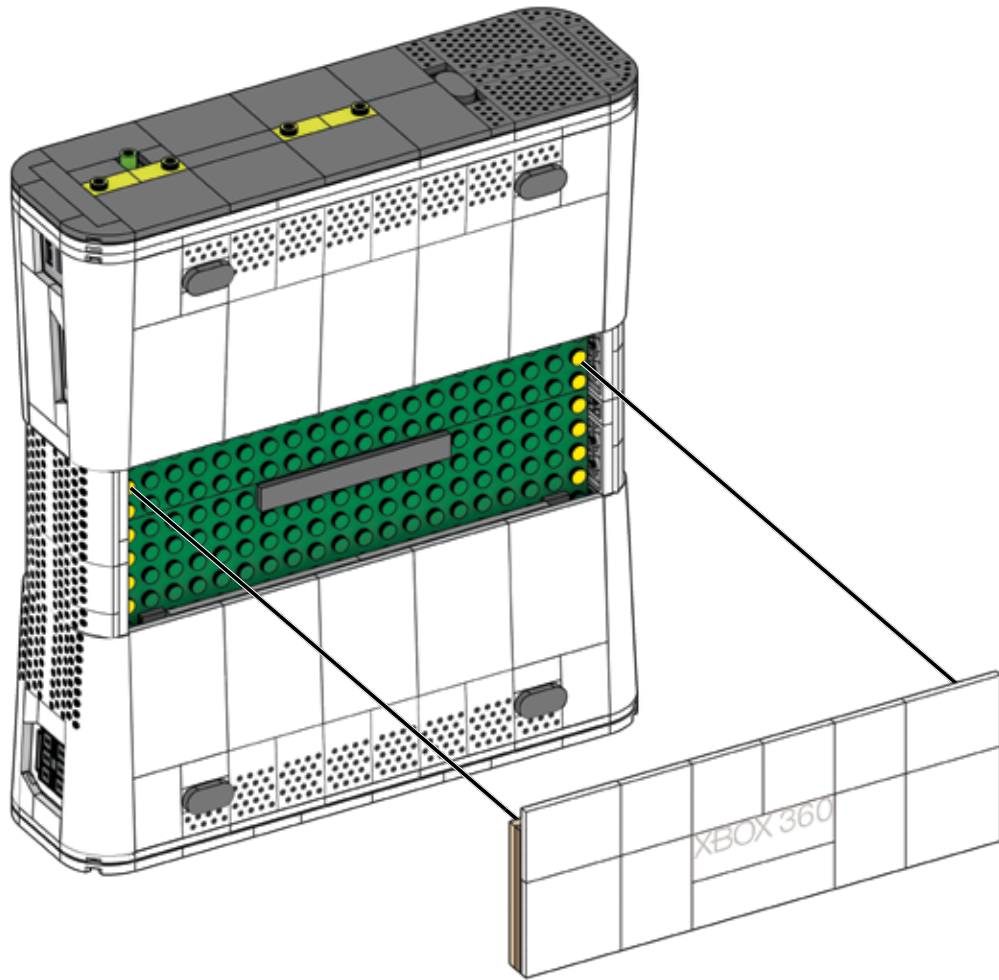

1

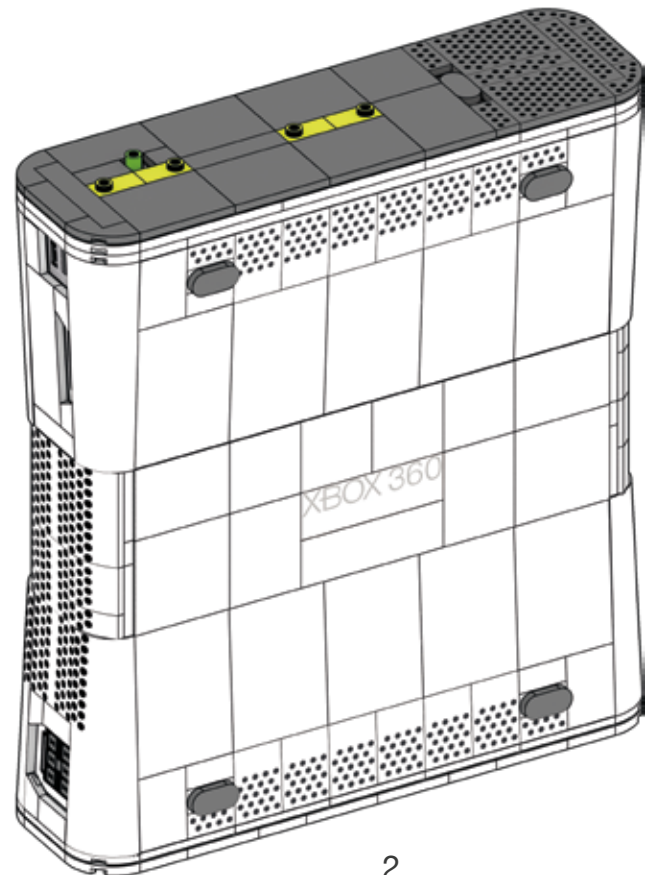

2

317



2x



8x

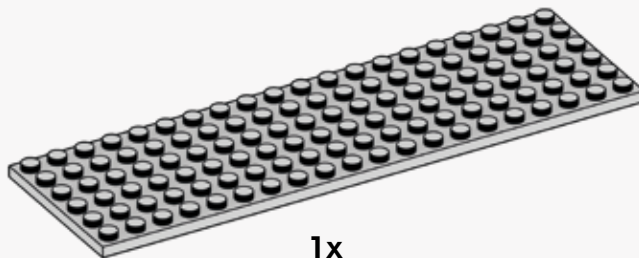

1x

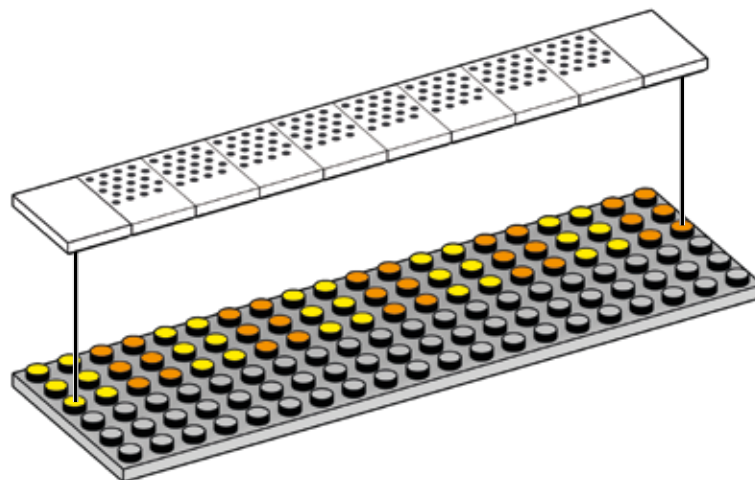

318

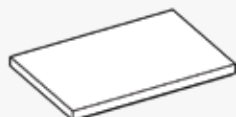

5x

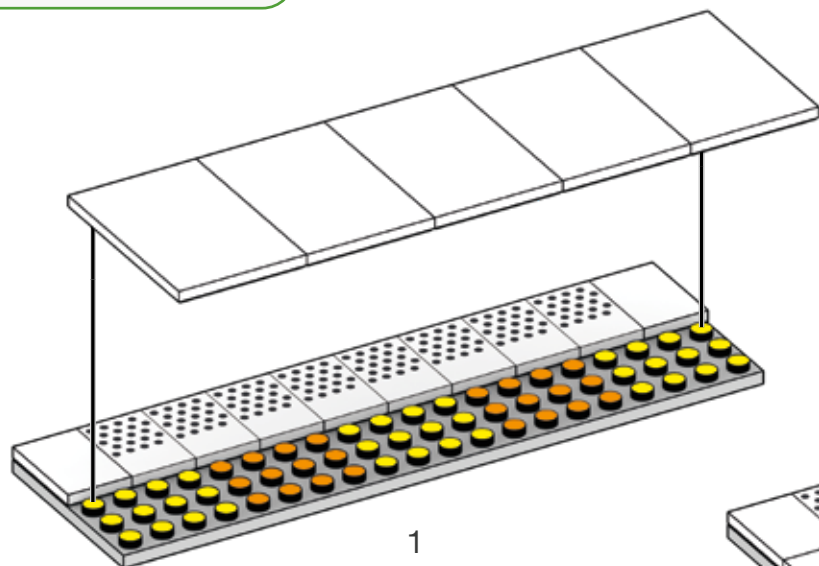

1

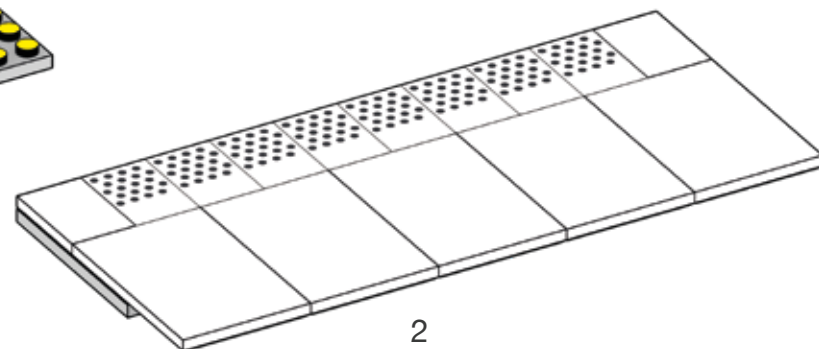

2

319

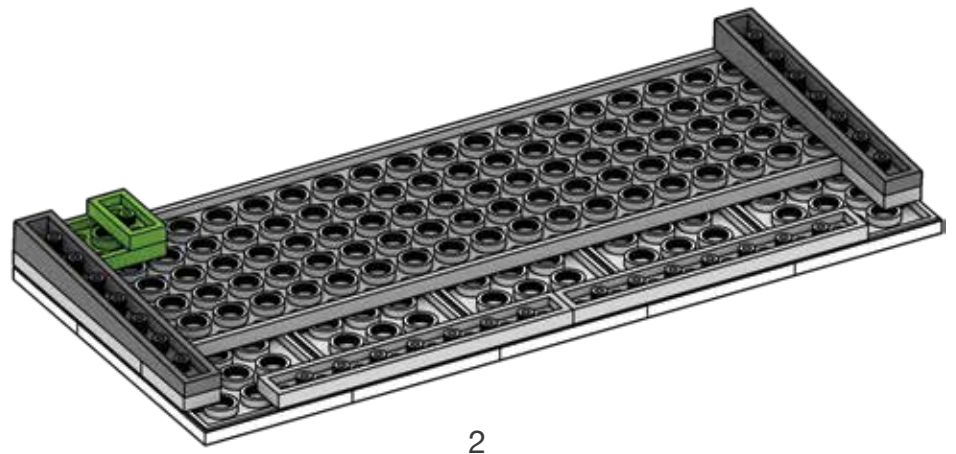
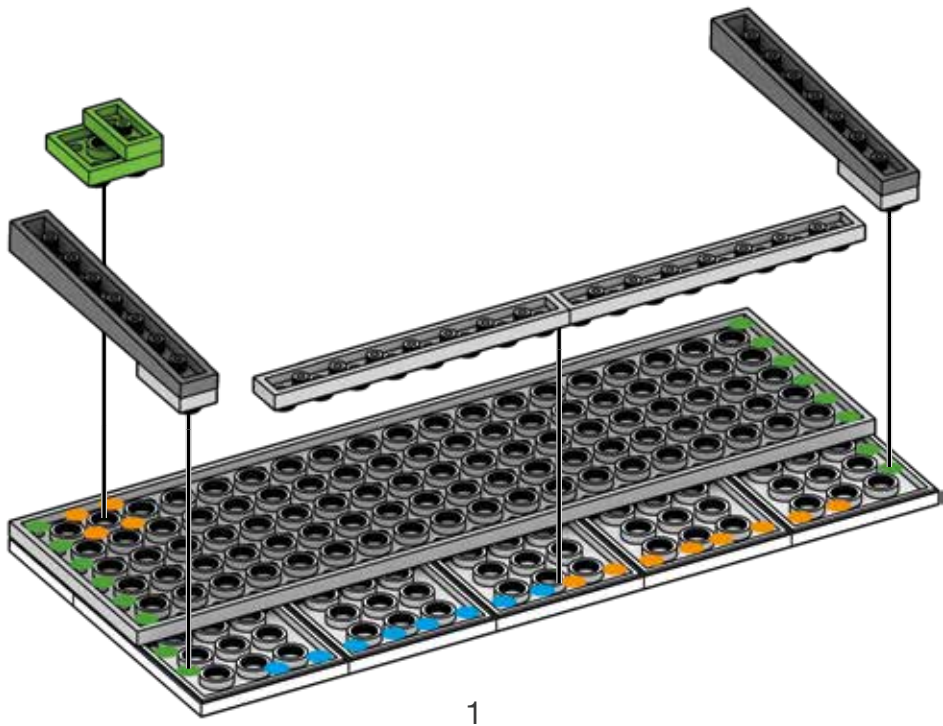
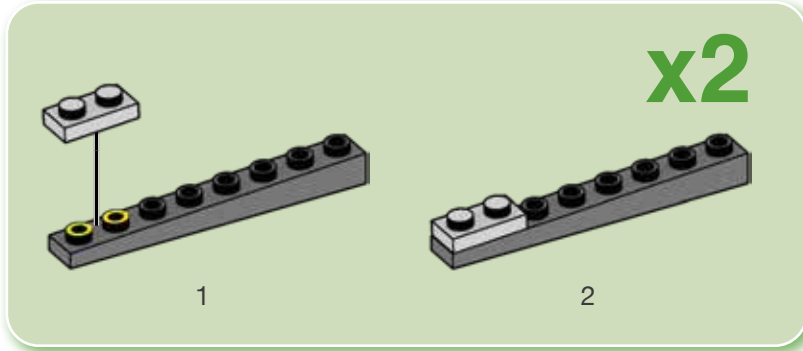
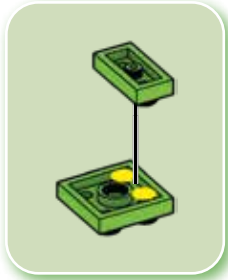
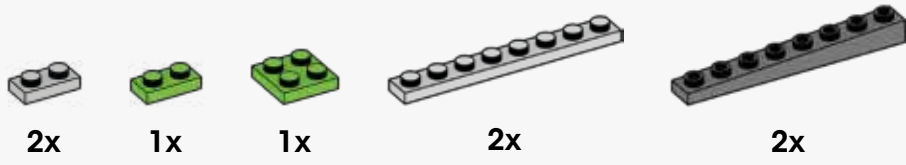

320

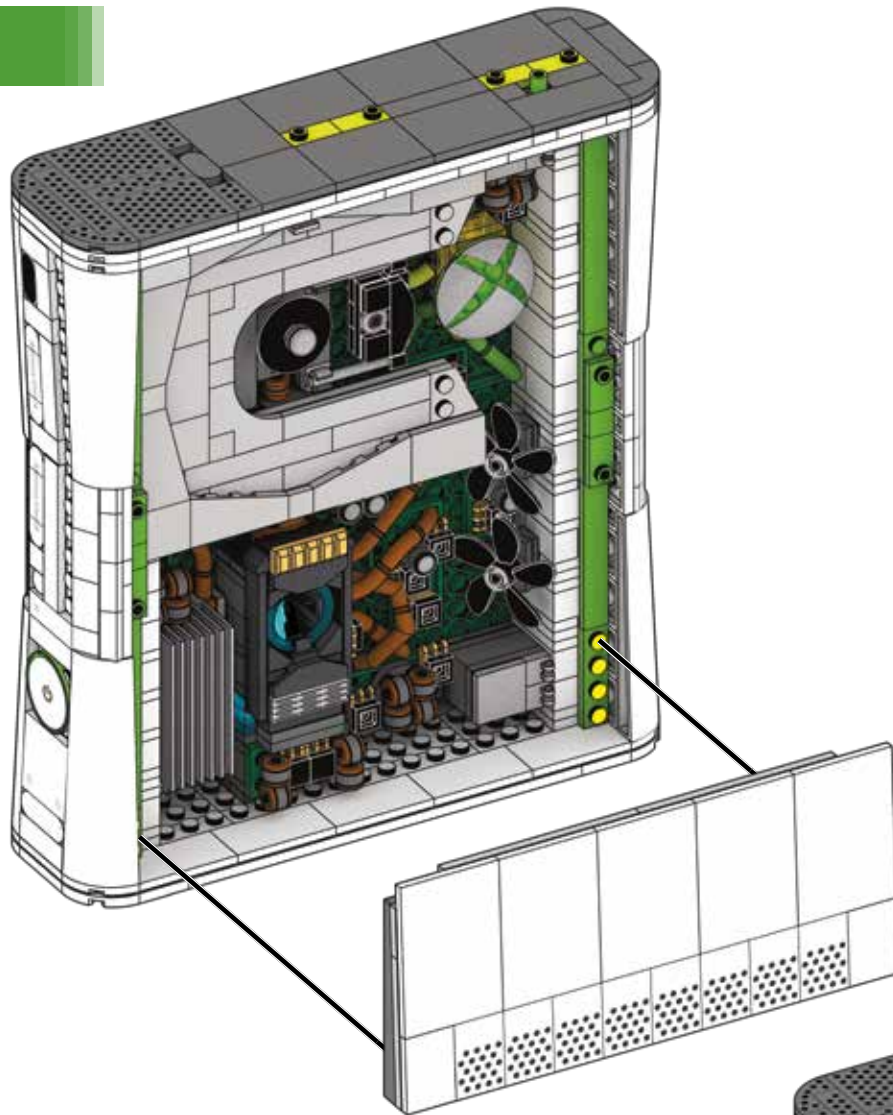

1

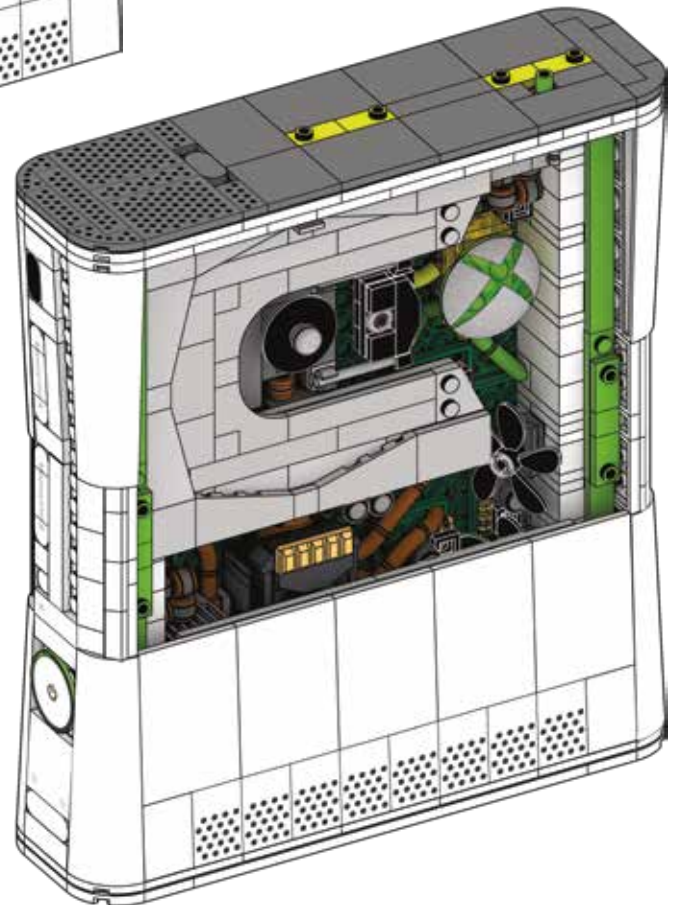

2

321



1x



1x



2x



2x

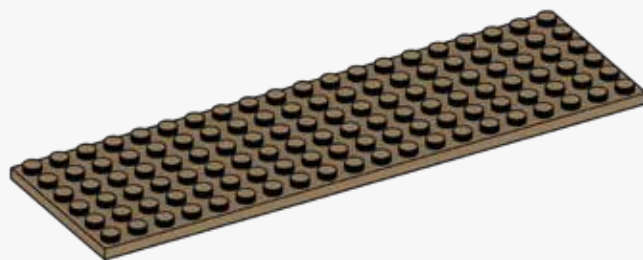

1x

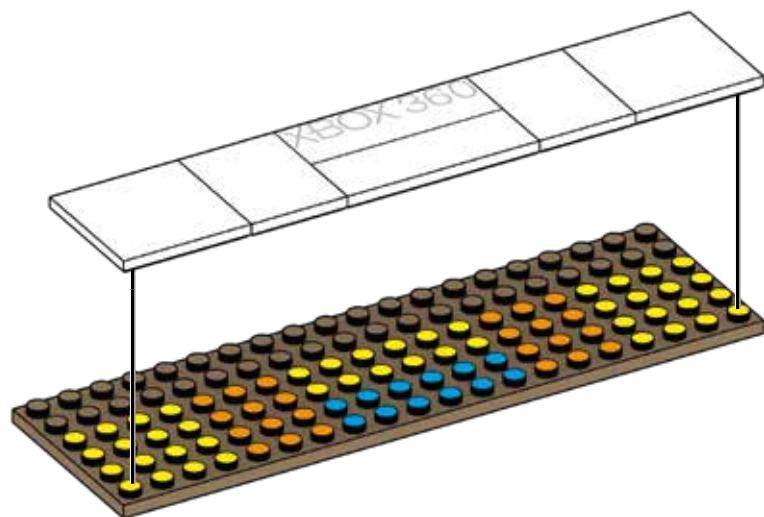

322



4x



2x

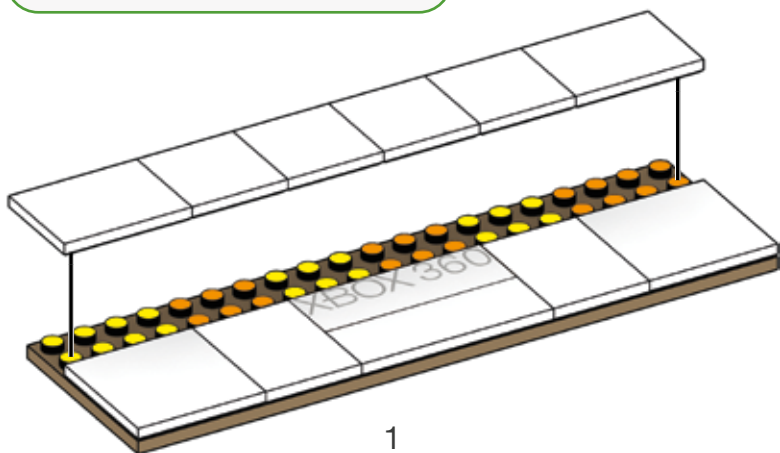

1

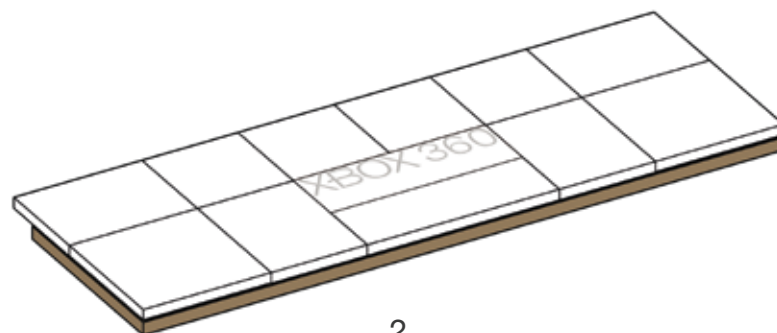

2

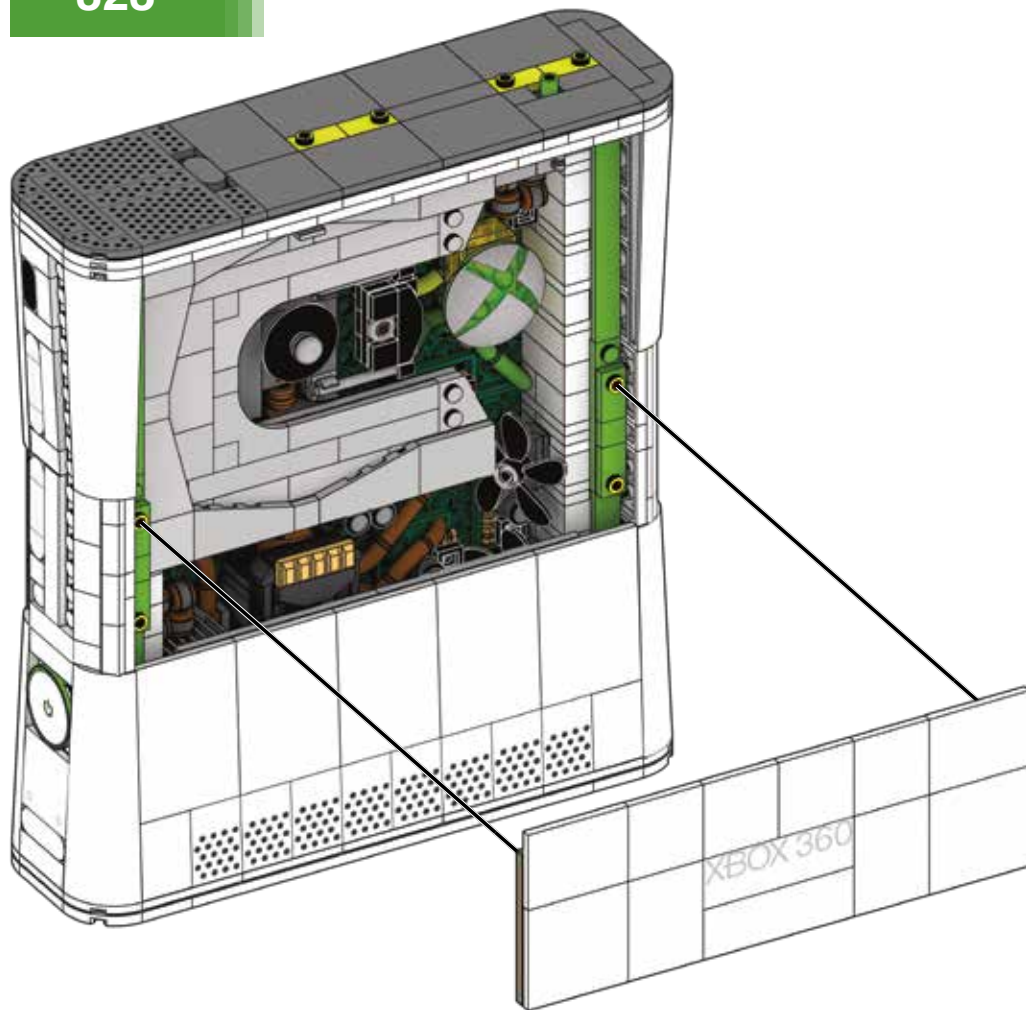

1

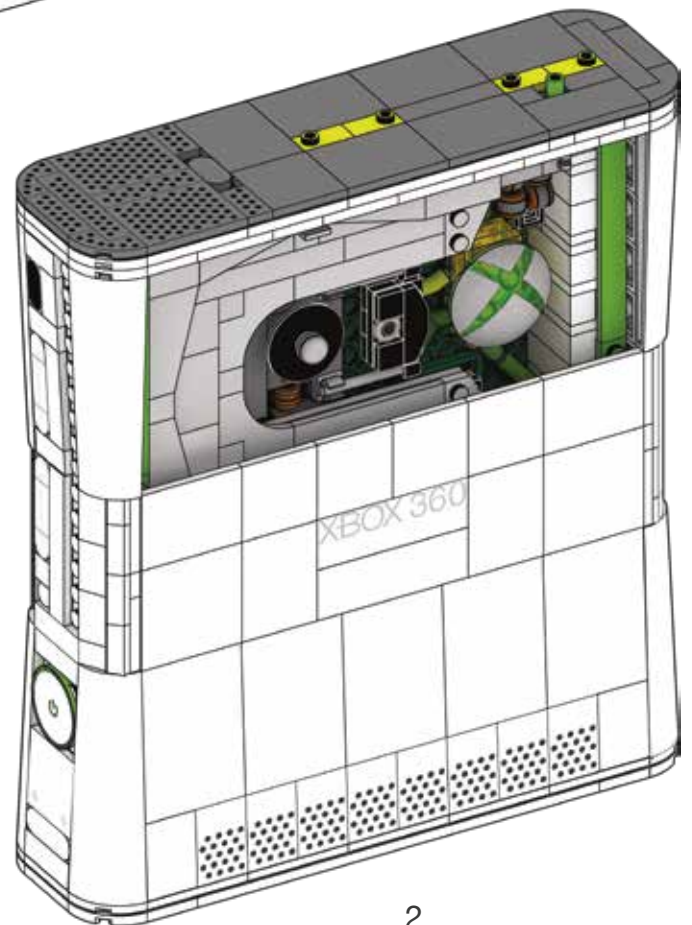

2

324



2x



8x

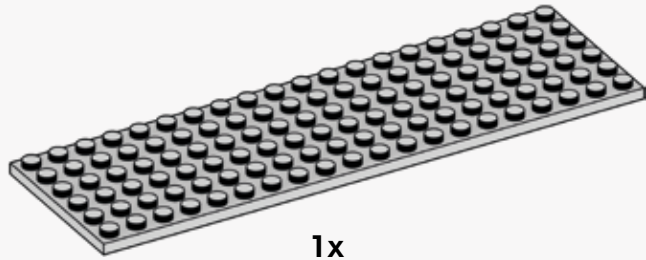

1x

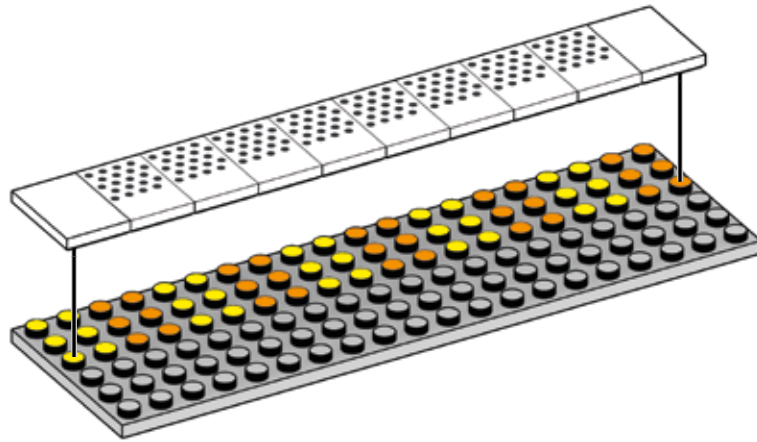

325

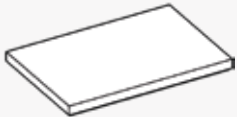

5x

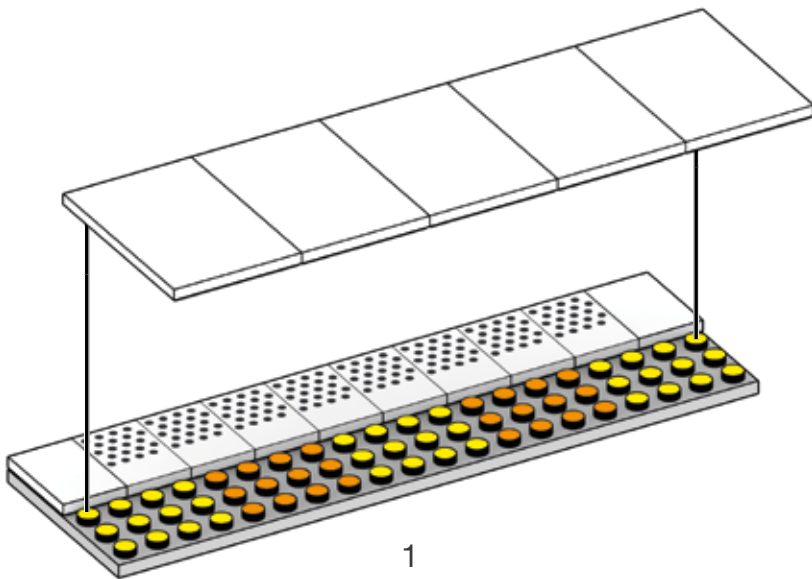

1

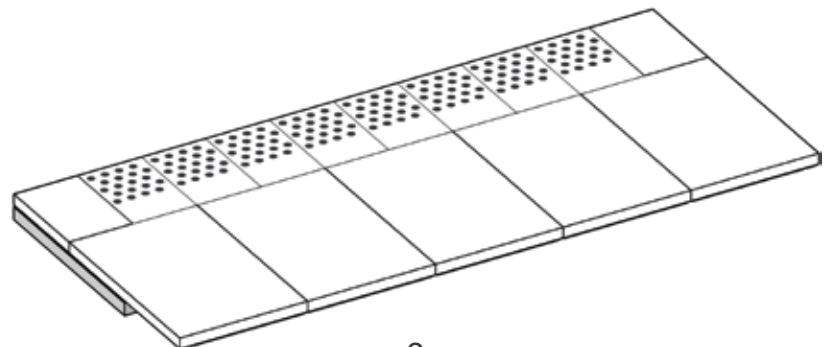

2

326

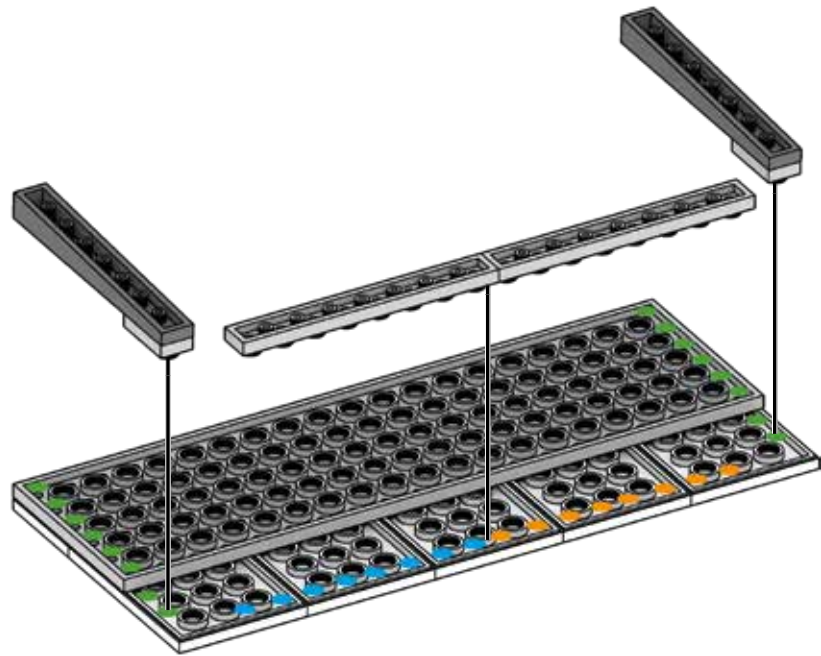
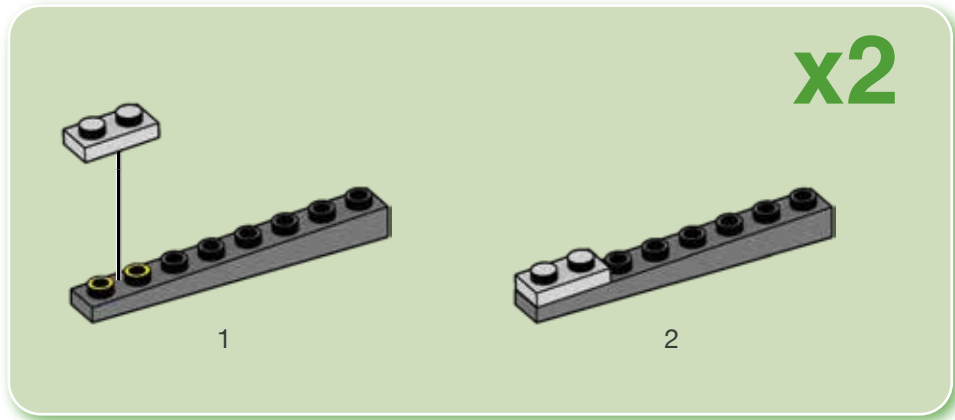

327



1x



1x

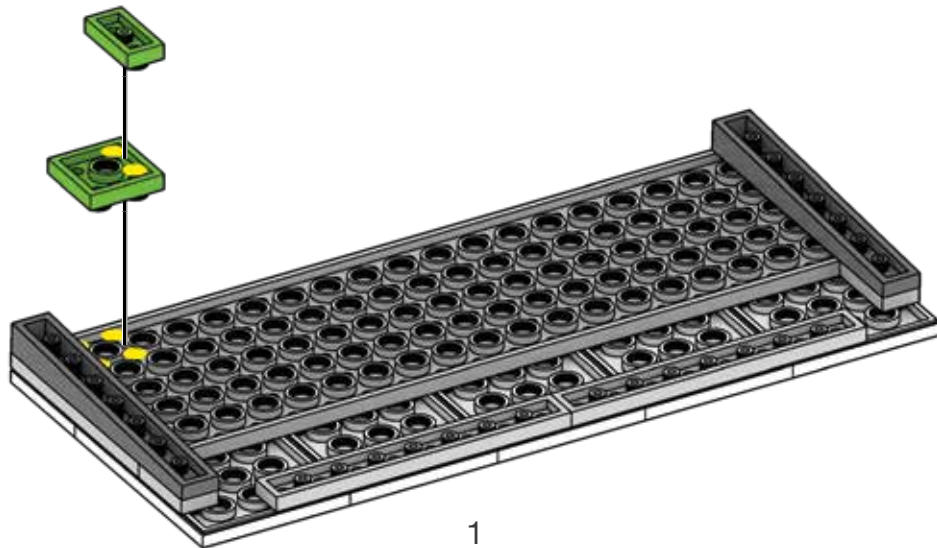

1

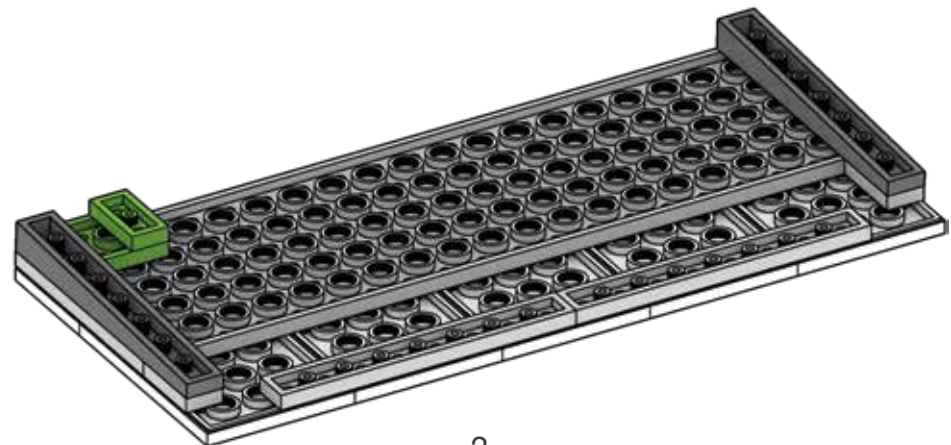

2

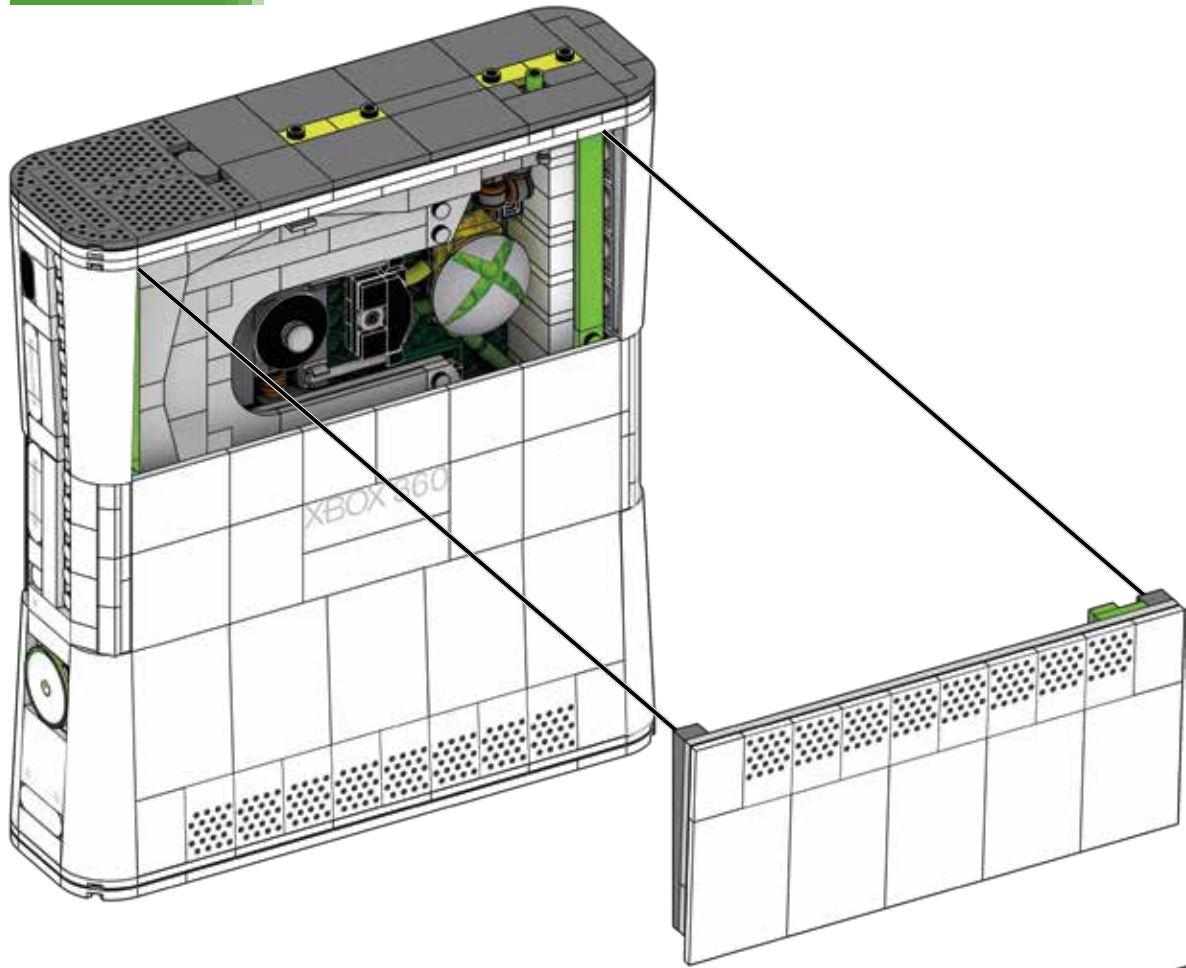

1

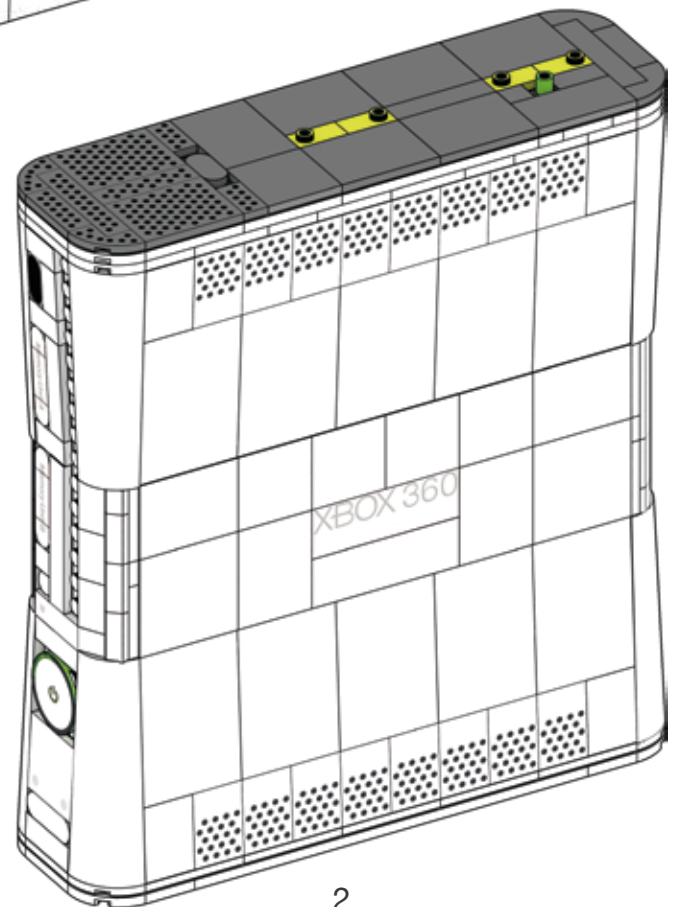

2

329



1x



1x



1x

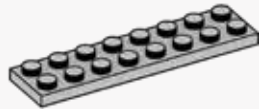

1x

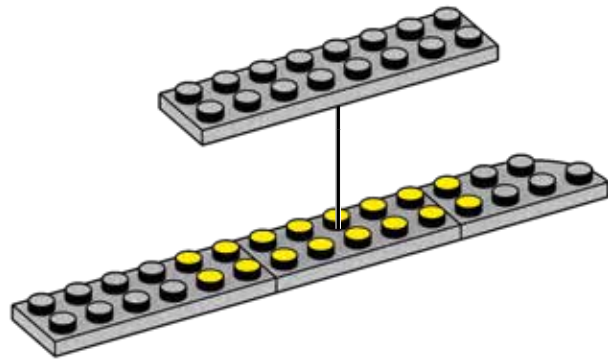

330



1x

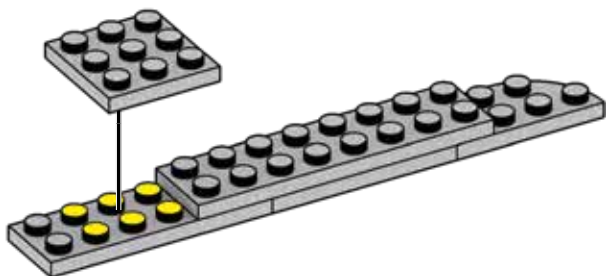

1

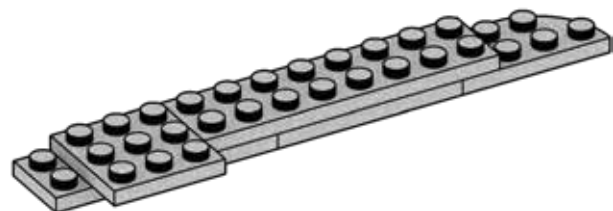

2

331



1x



1x



1x



1x

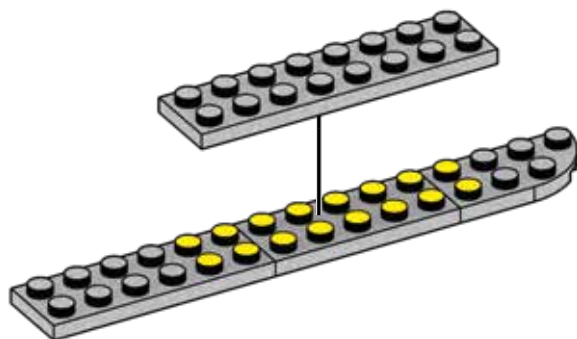

332



1x



1x

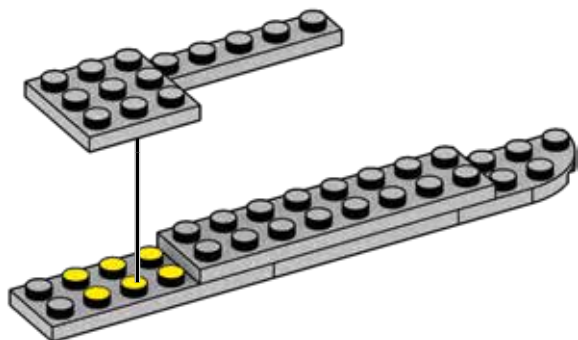
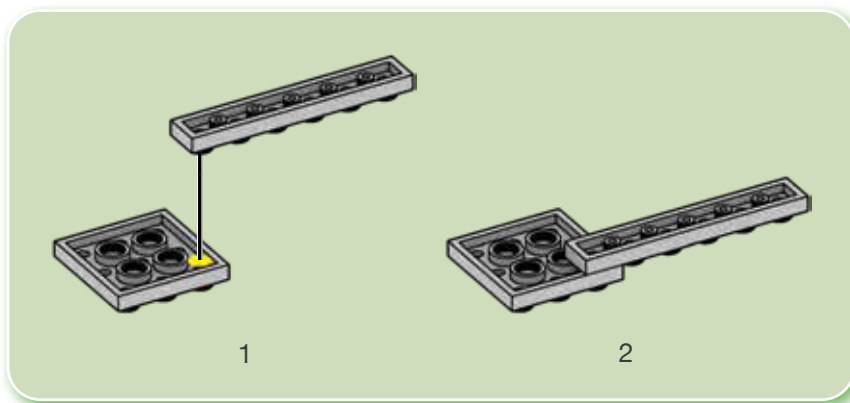

1

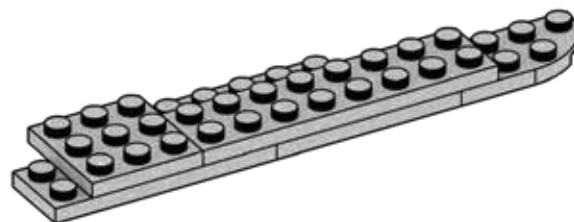

2

333



1x



1x

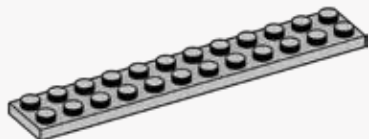

1x

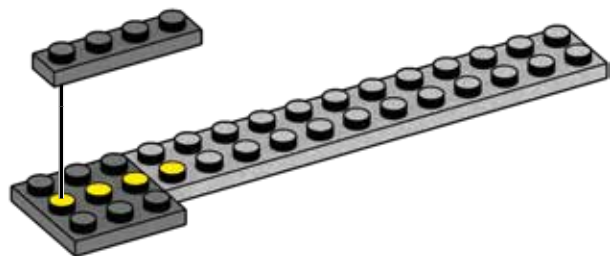

334

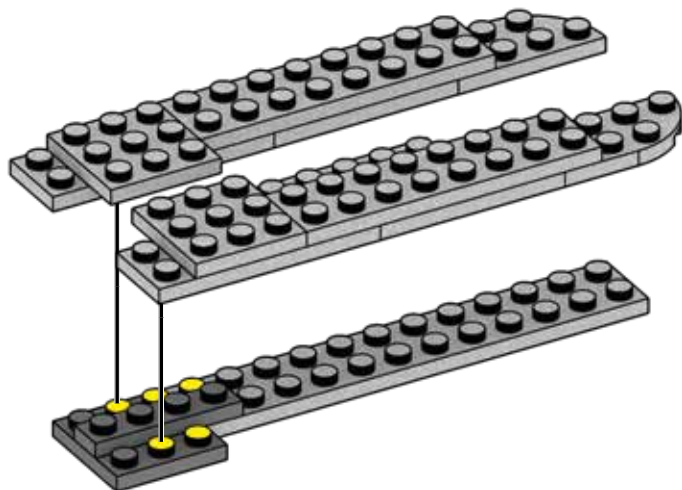

335



7x

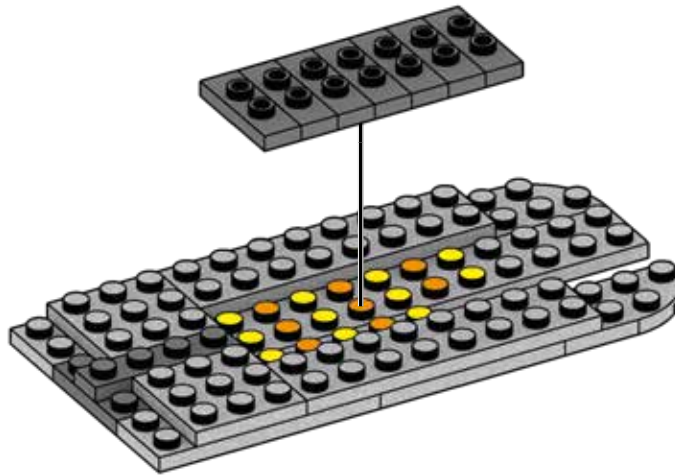

336



1x



1x

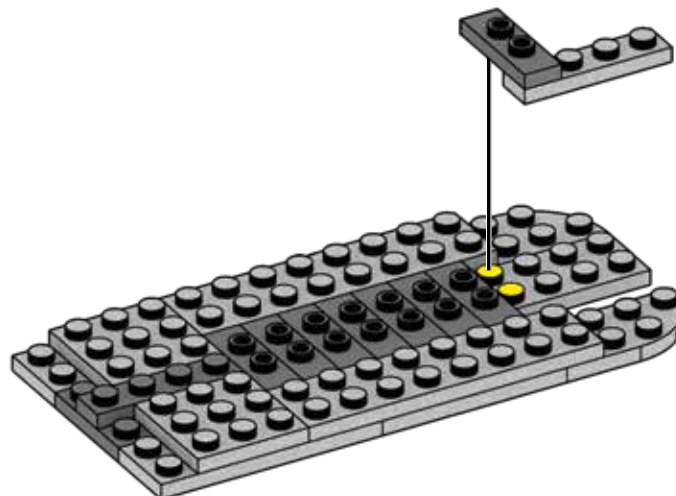
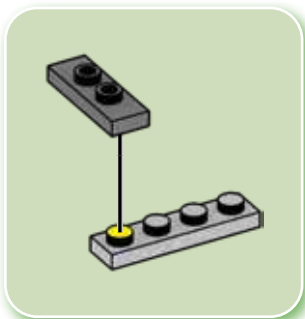

337

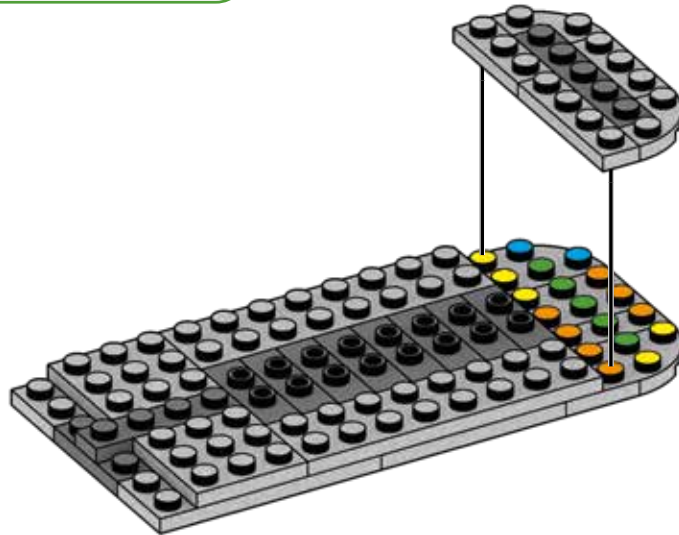
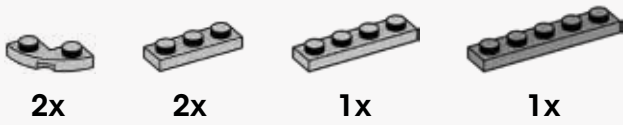

338

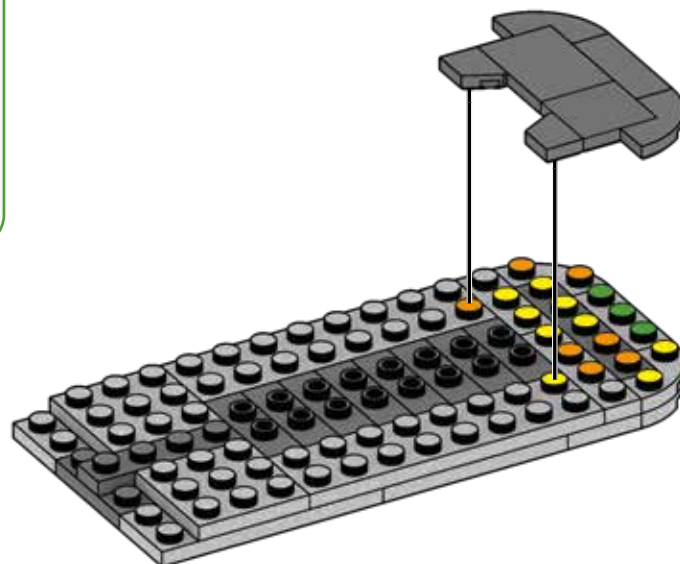
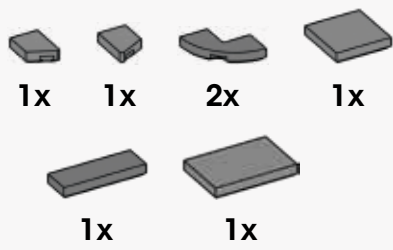

339

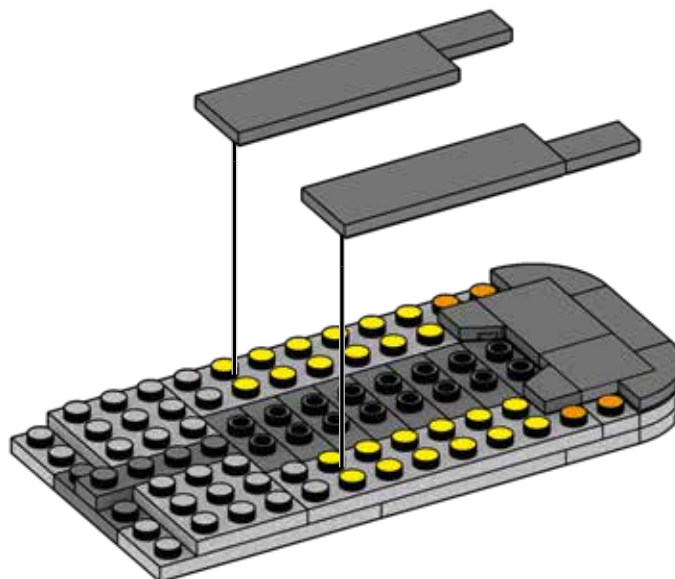
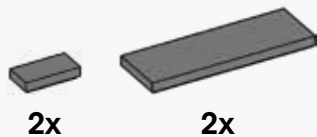

340

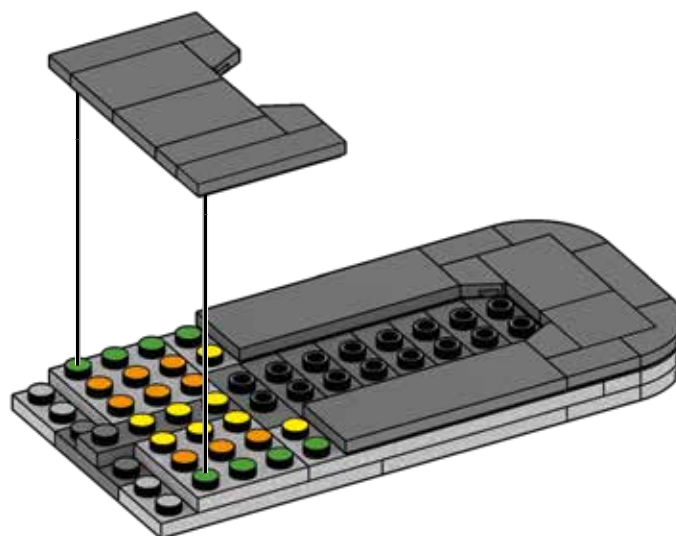
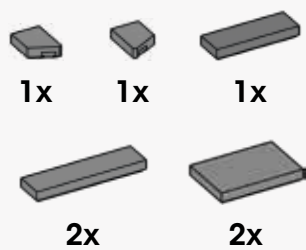

341



1x



1x



1x

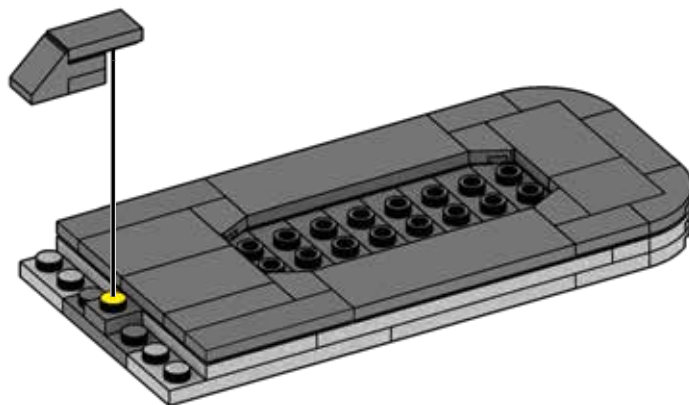
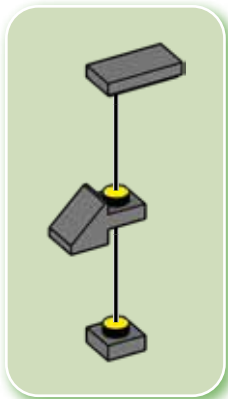

342



1x



1x

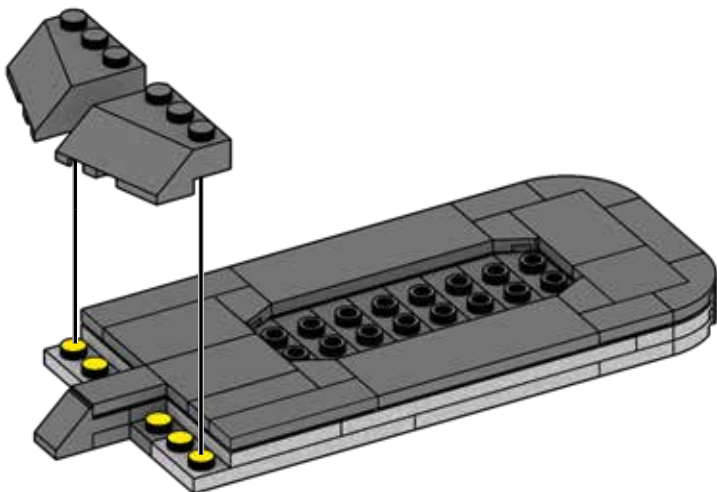

1

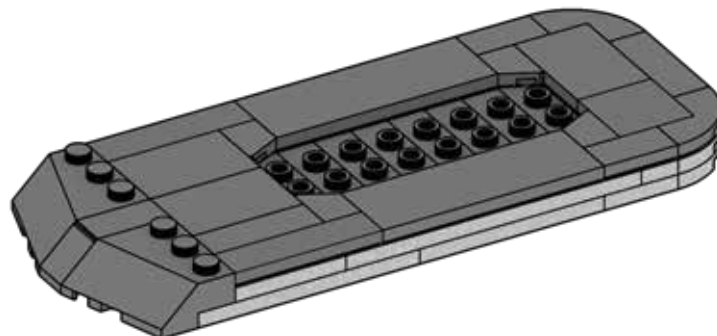

2

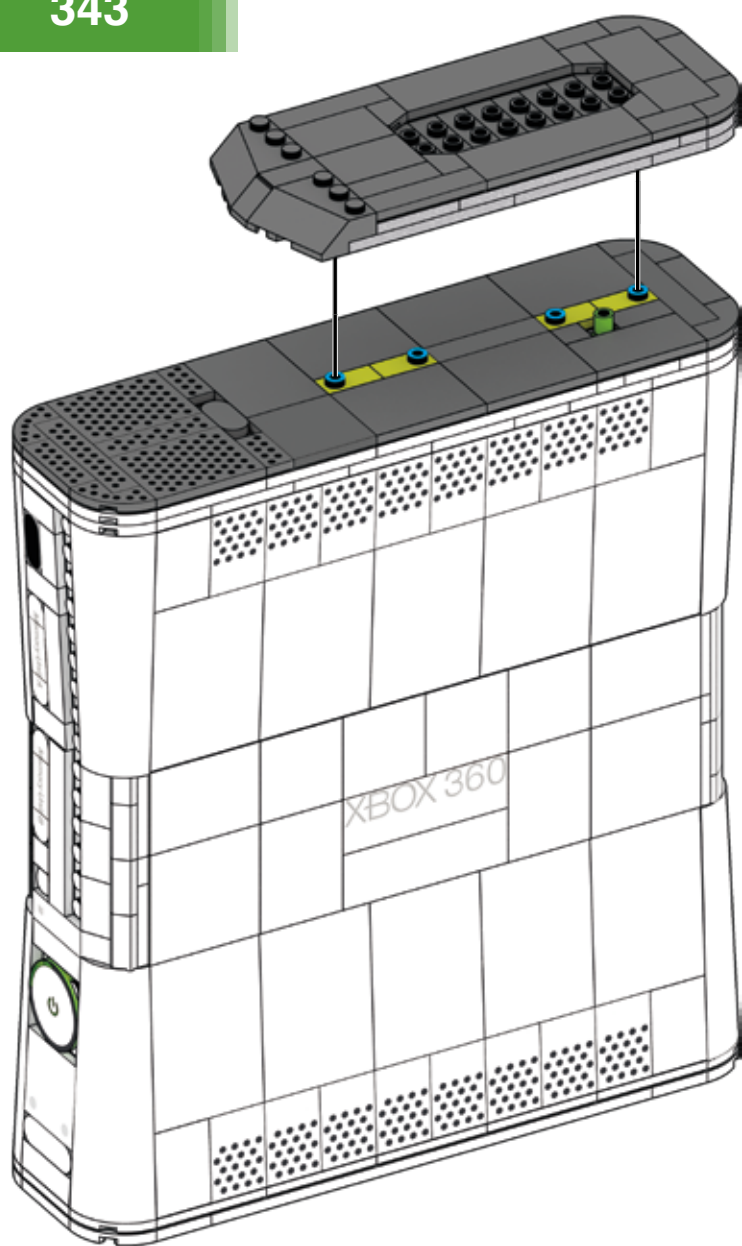

1

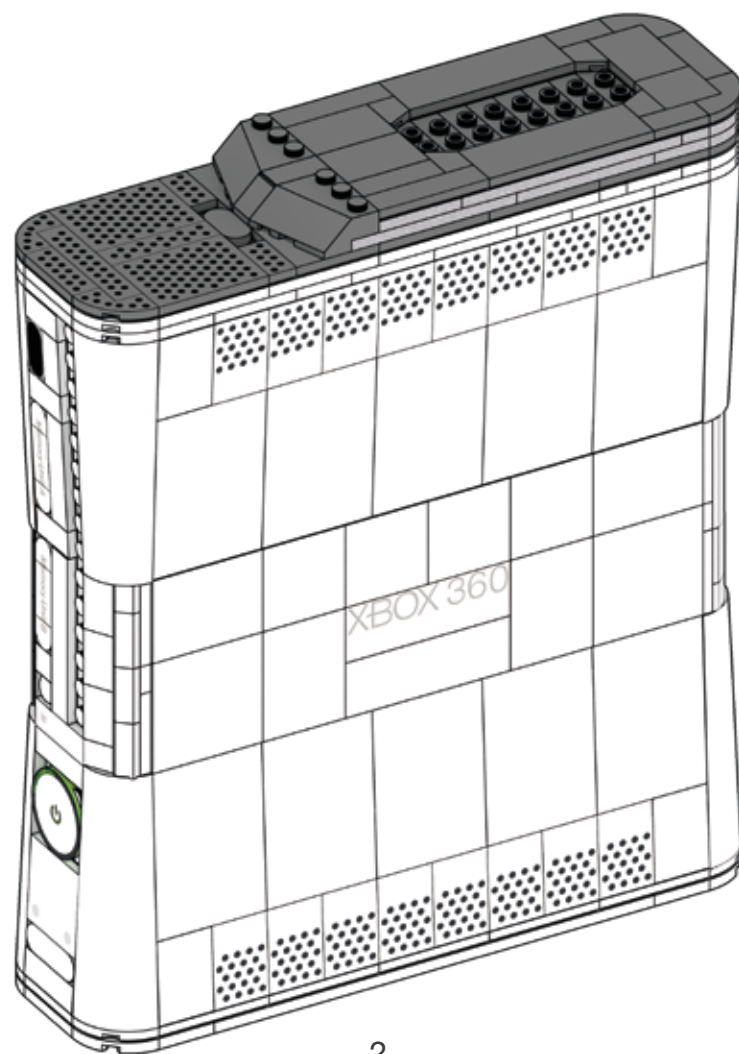

2

344



4x



1x



2x

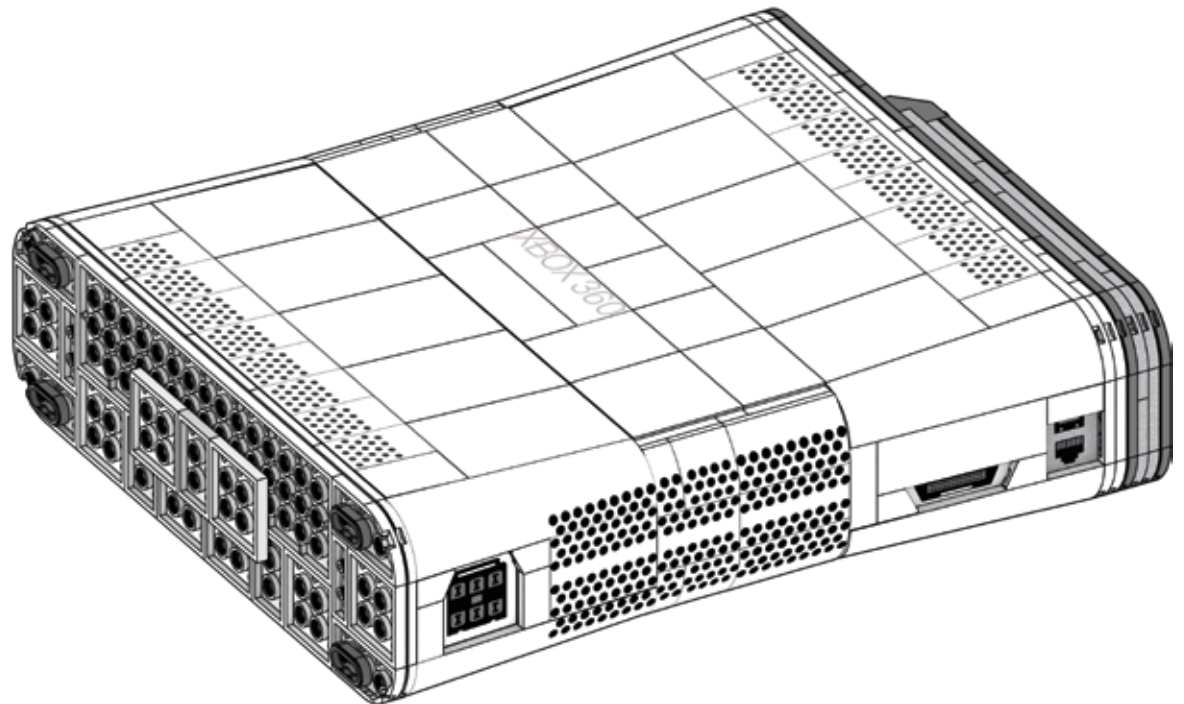
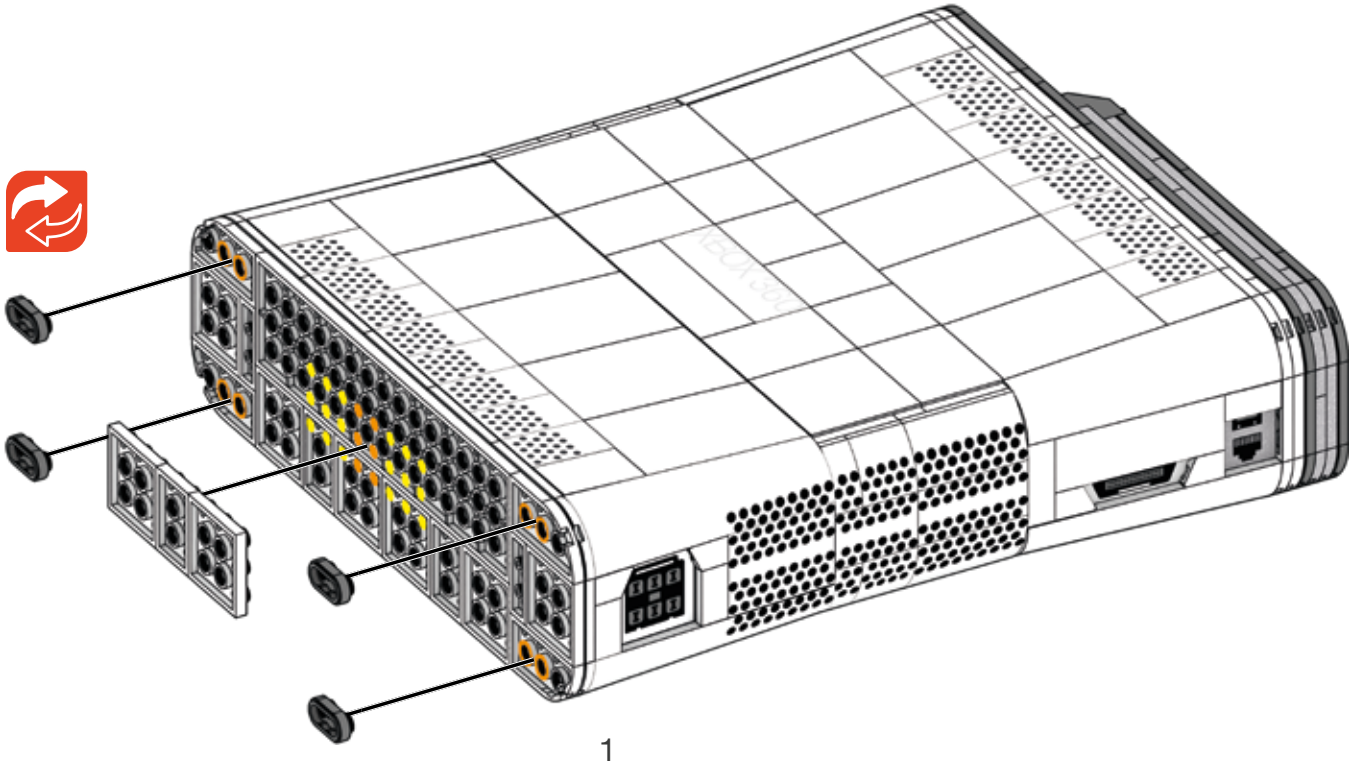

23

345



2x



1x

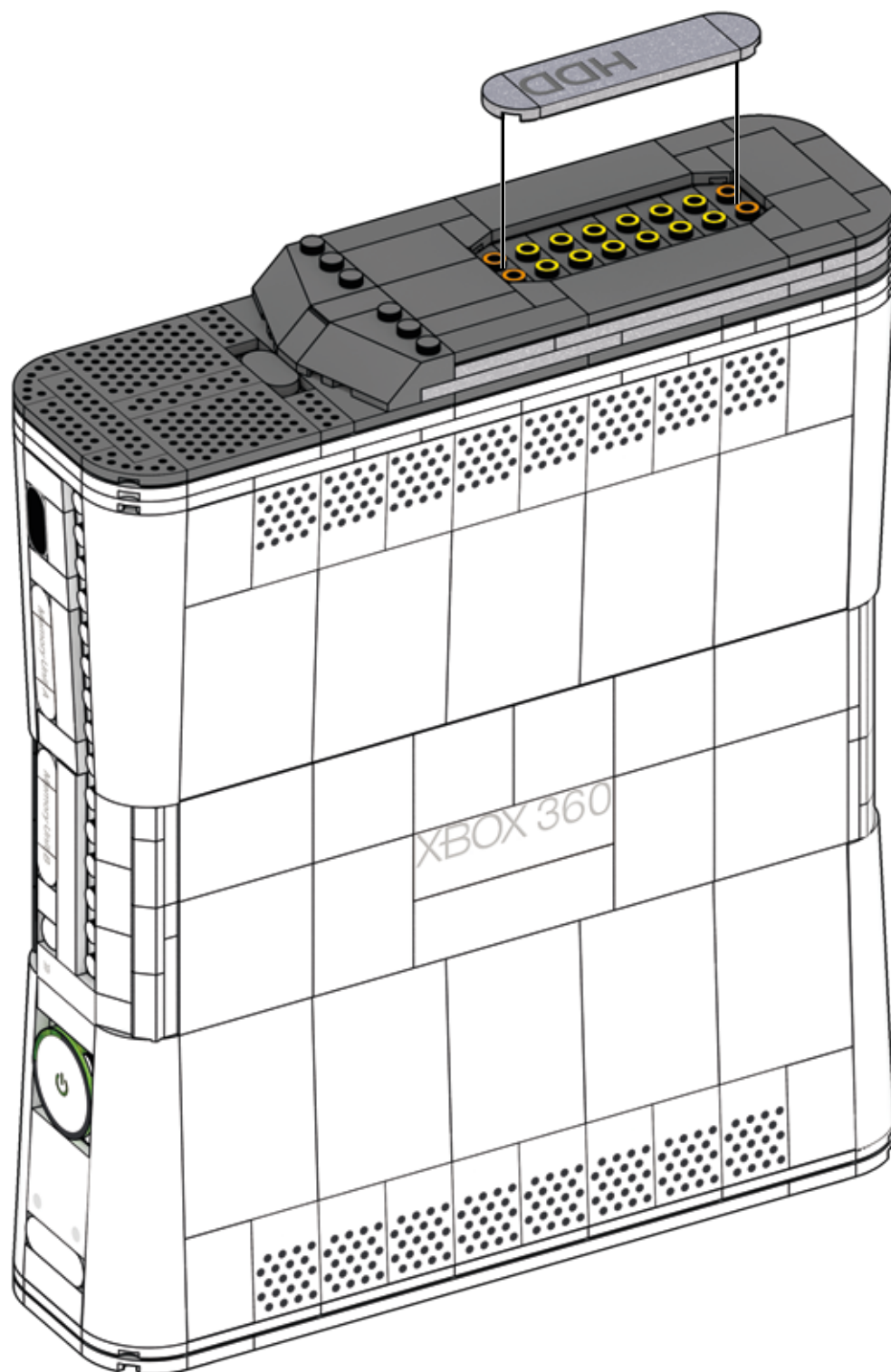

346

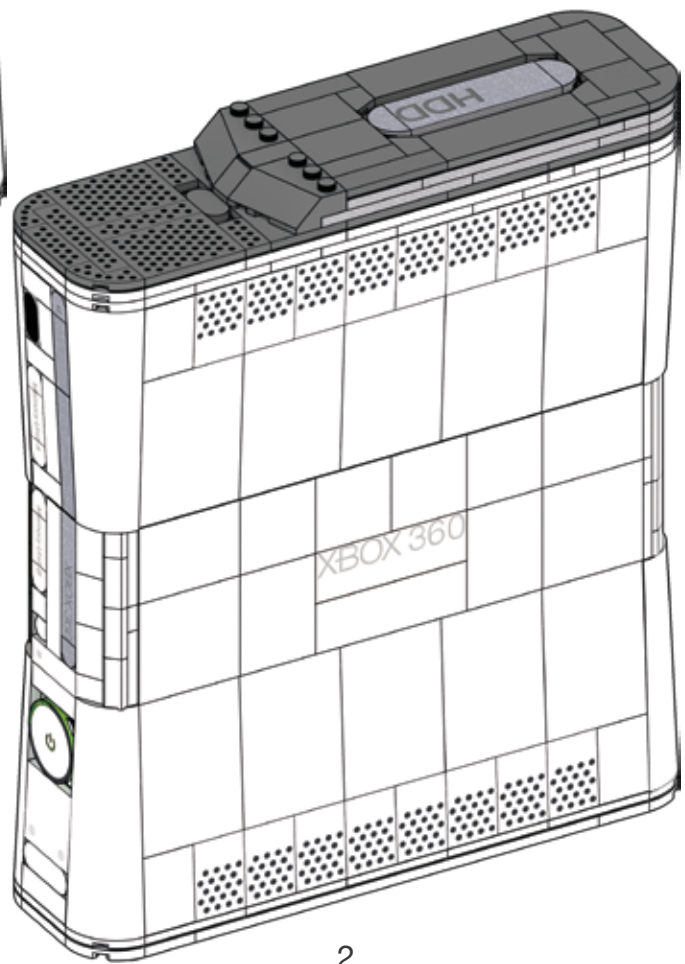
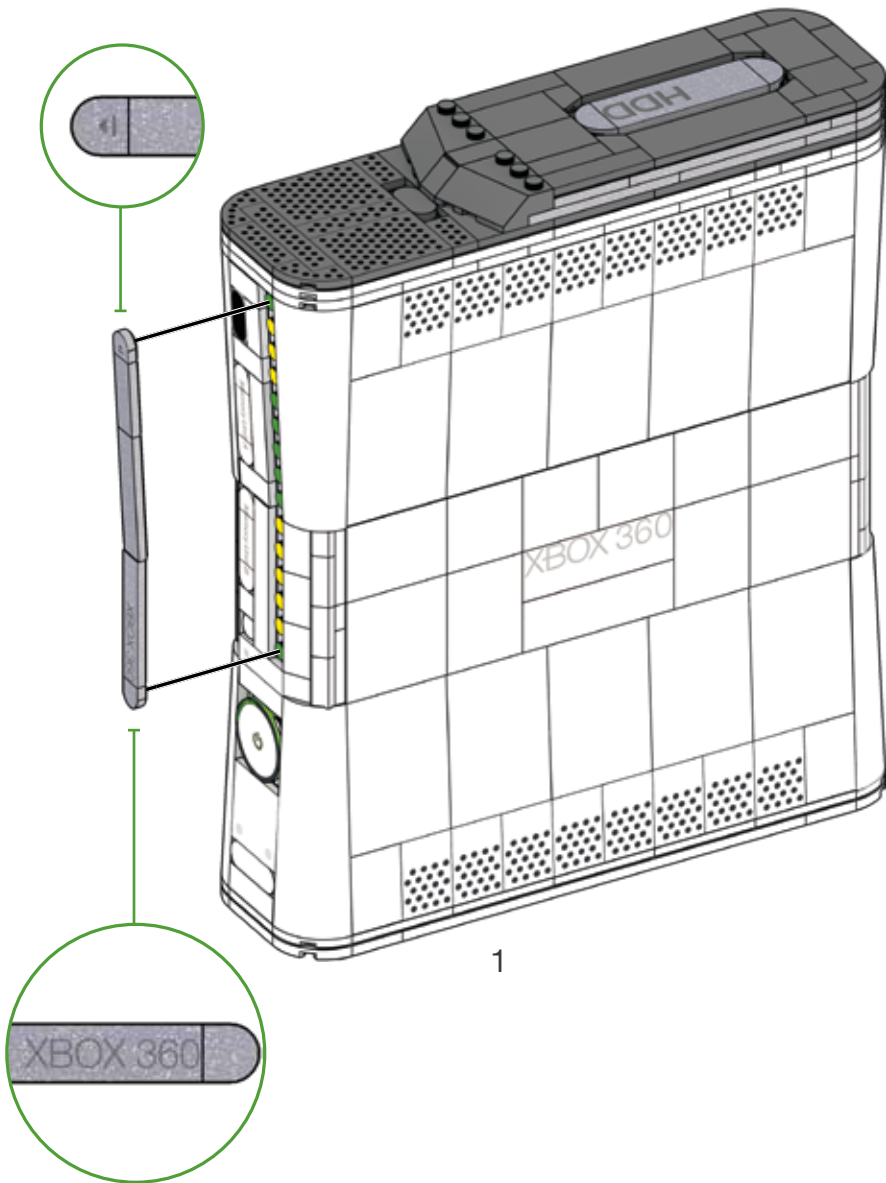
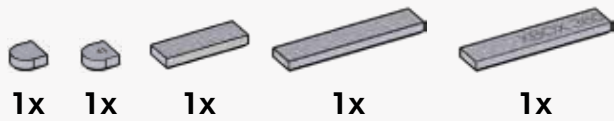



347

4x

2x 1x

1x

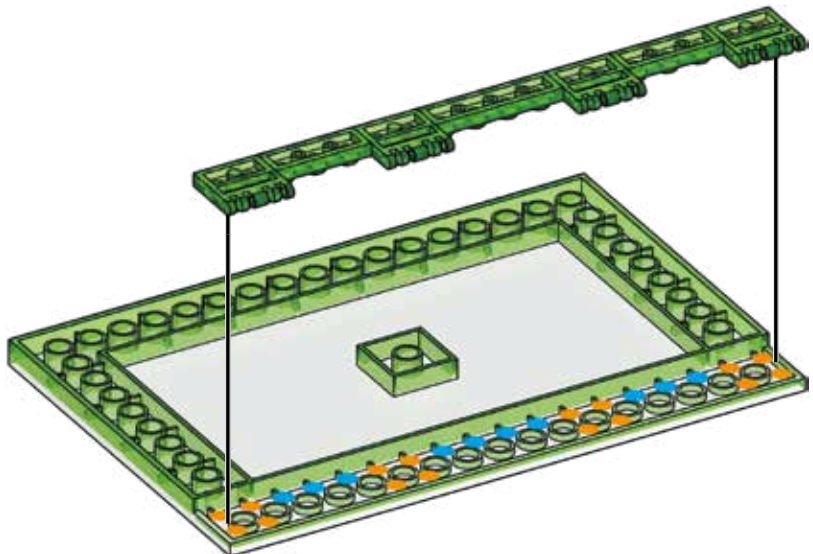

348

2x 6x 2x

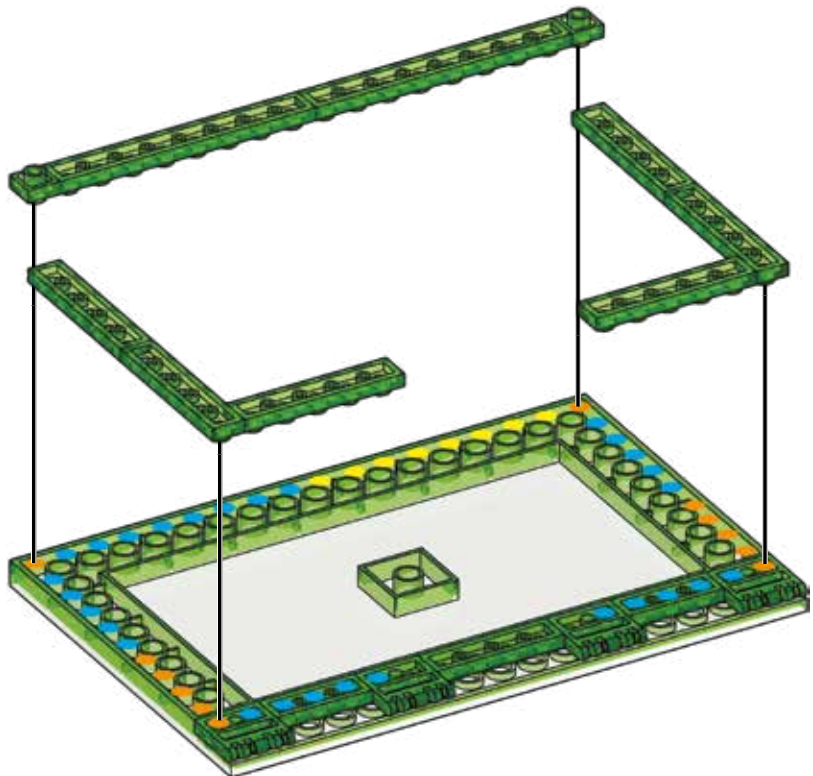

349



1x



1x

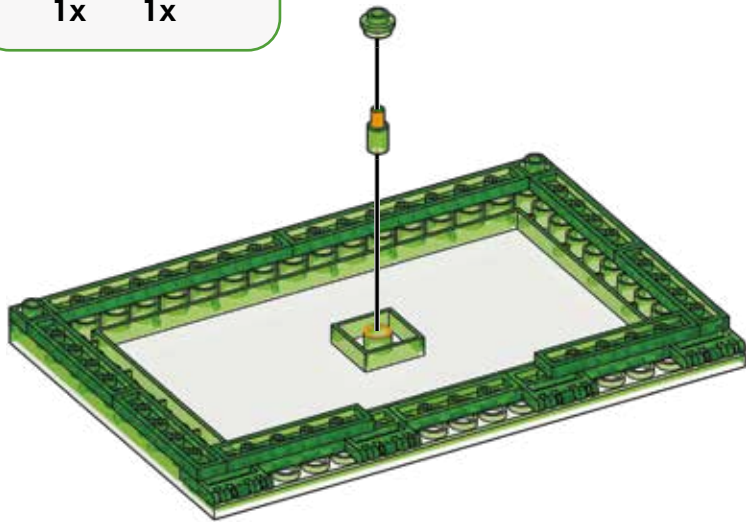

1

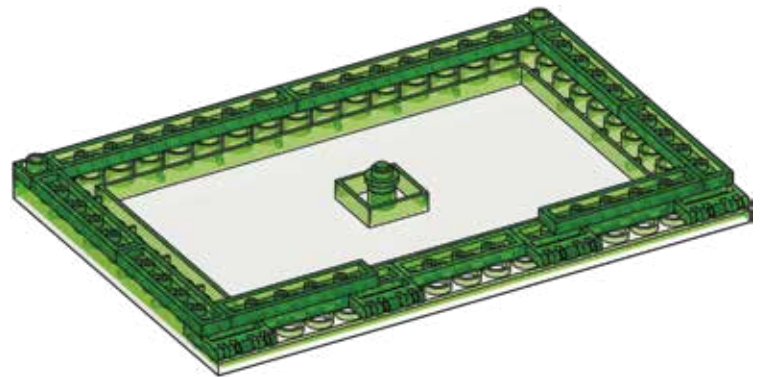

2

350



2x



1x



1x

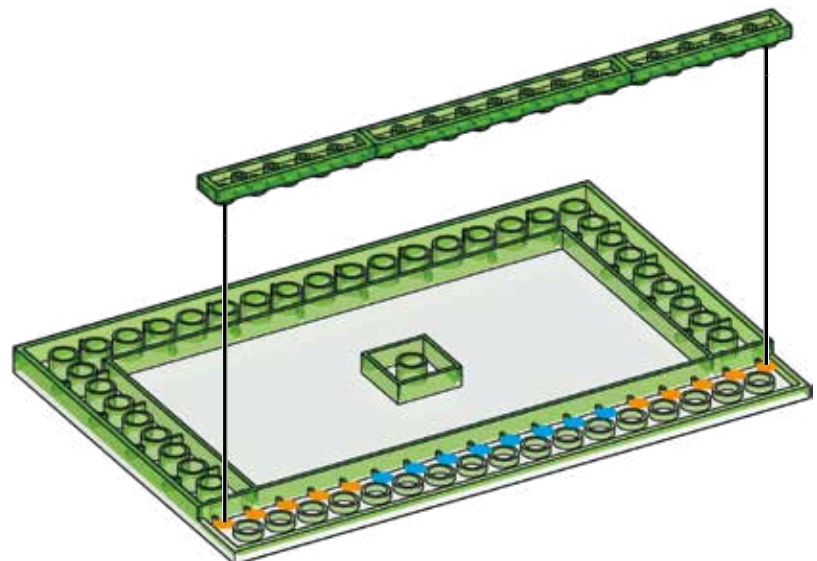

351



6x

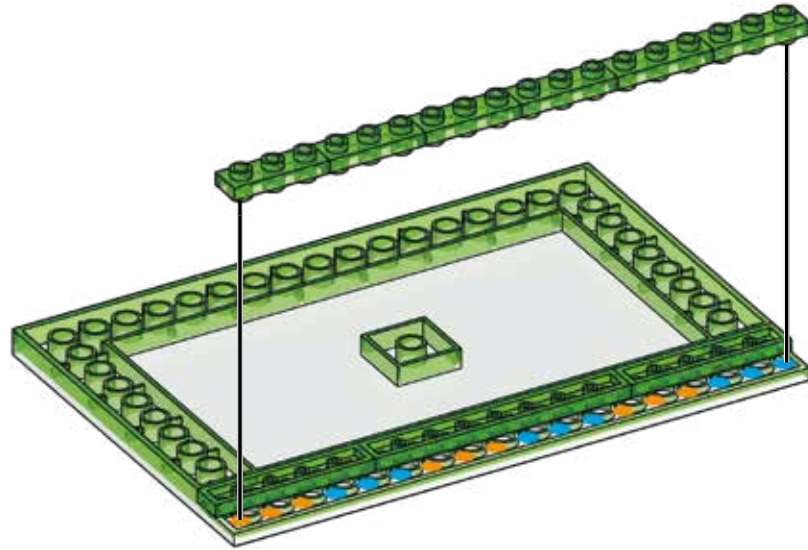

352



8x

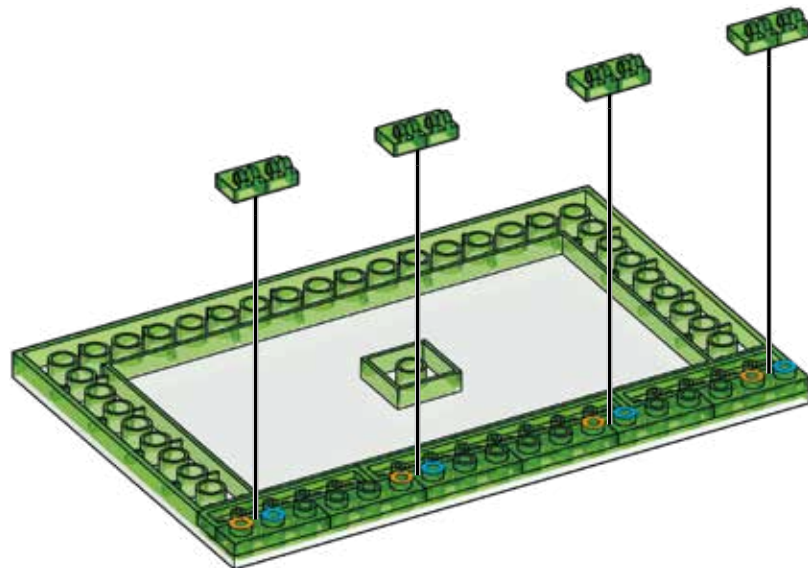

353



4x



3x

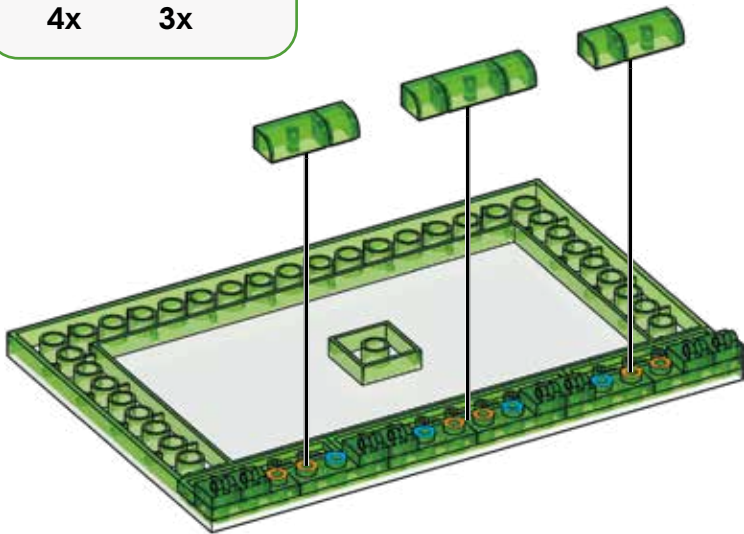

1

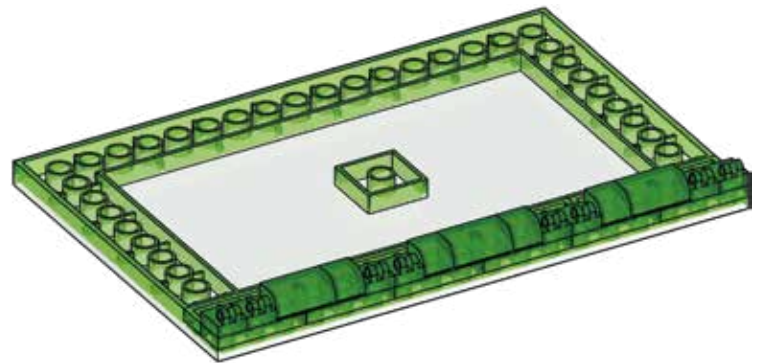

2

354

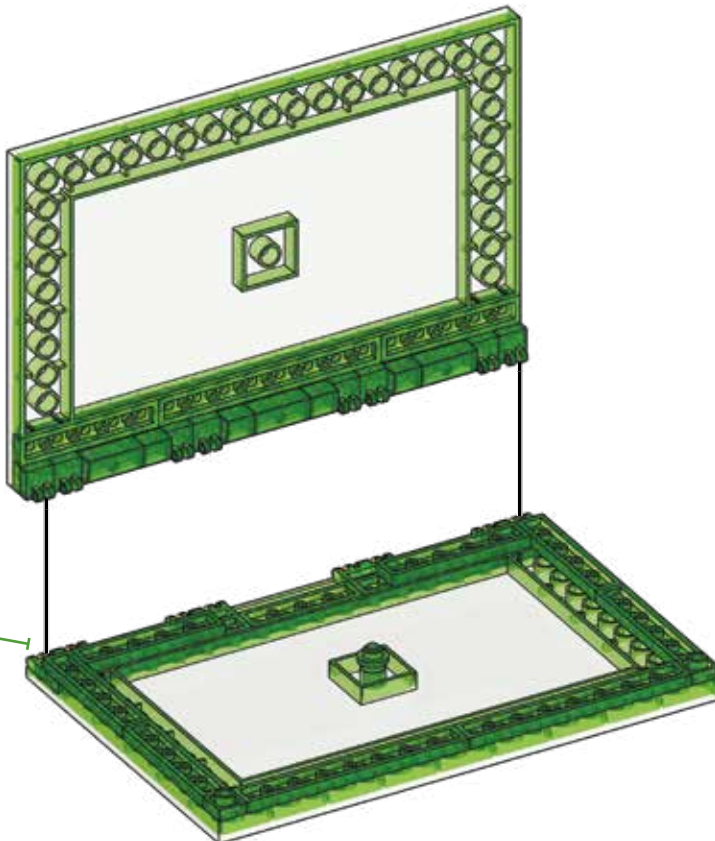
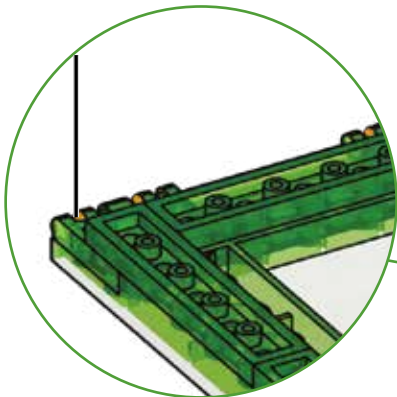

355



1x

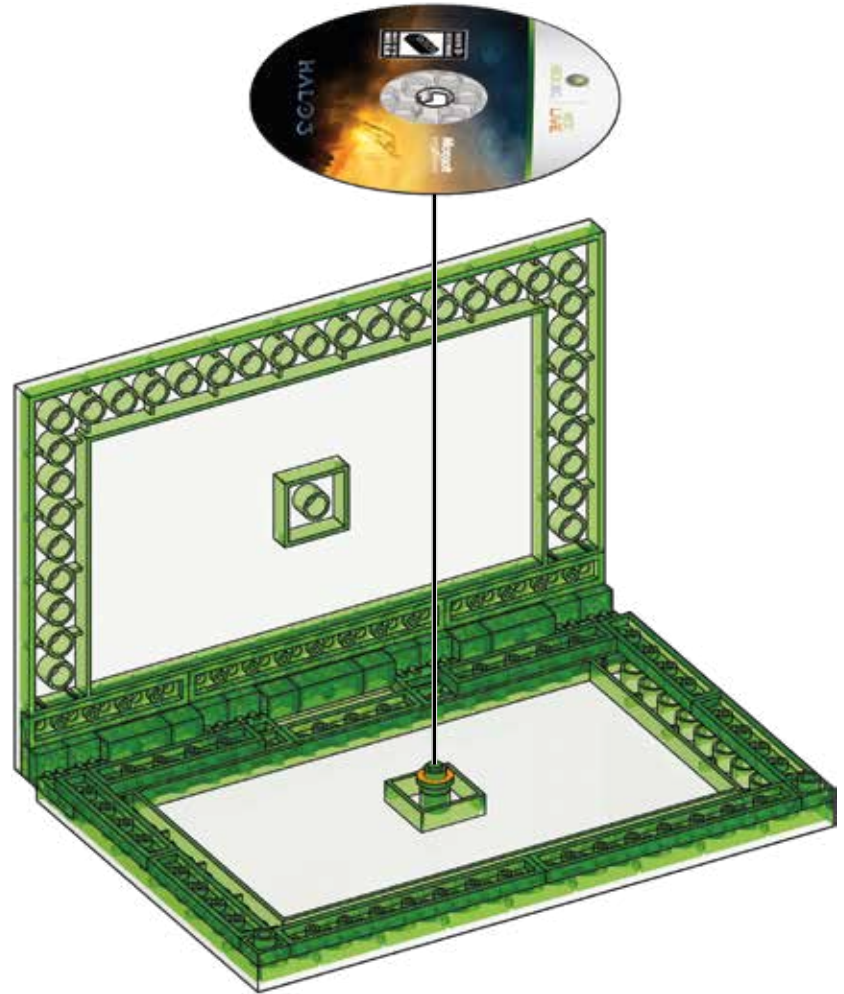
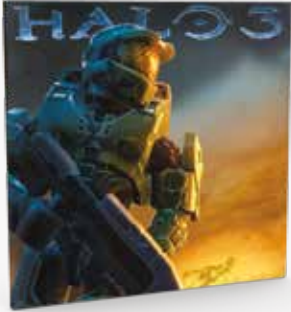

1



2



3

356



1x

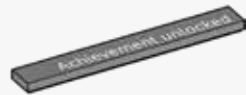

1x



1x

or
ou
o
или



1x



1x

Achievement unlocked
75G - Build an Xbox!

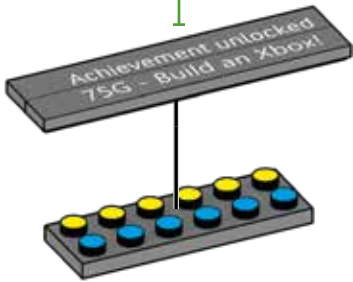

or
ou
o
или

Succès déverrouillé
75G - Construis une Xbox!

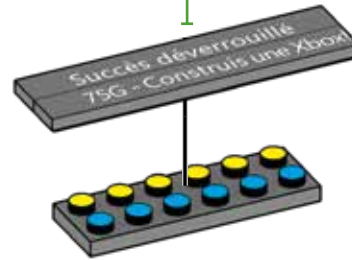

357



1x



1x

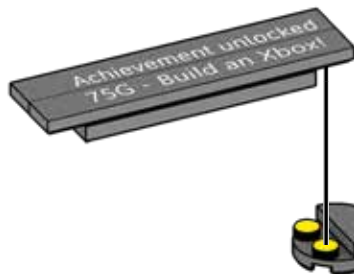

358



1x



1x



359



1x

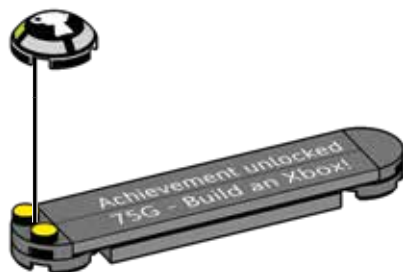

1



2

360



1x

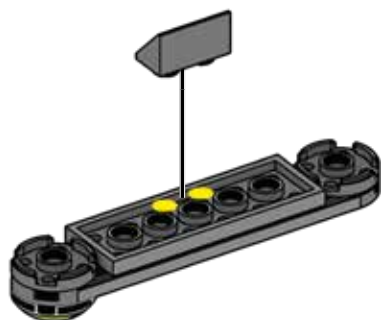

1

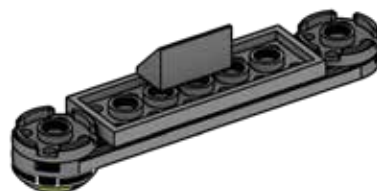

2



3





XBOX 360



COLLECTOR BUILDING SET
BOÎTE DE CONSTRUCTION
POUR COLLECTIONNEUR

SET DE CONSTRUCCIÓN PARA COLECCIONISTAS / CONJUNTO DE CONSTRUÇÃO PARA COLECCIONADORES / BAUSET FÜR SAMMLER / КОЛЛЕКЦИОННЫЙ НАБОР ДЛЯ СБОРКИ



3:4 Scale Model / Échelle / Modelo a escala / Modelo à escala / Modell im Maßstab / Модель в масштабе

1



2





Light-up Xbox Sphere and Cortana chip La sphère Xbox et puce Cortana s'allument

El orbe de Xbox y el chip de Cortana se iluminan
Cortana e logótipo da Xbox com luzes
Leuchtende Xbox-Kugel und Cortana-chip
Загорающаяся сфера Xbox и Чип Кортана





1x AM77583HT	1x AS-HWW15-56	3x AM09104APG	2x AM74300BDG	1x AM80546AFE	1x AM79375BDG	1x AM16680BDG	15x AM79070AFE
1x AS-HWW15-07	1x AS-HWW15-51	8x AM09104WH	2x AM74300AFE	21x AM80010BDG	1x AM79288BDG	1x AM16680WH	1x AM79070APG
1x AS-HWW15-06	1x AS-HWW15-35	13x AM09105AWU	2x AM74299BDG	1x AM76058ARC	2x AS-HWW15-53	2x AM16680BLG	2x AM76467BDG
1x AS-HWW15-08	1x AS-HWW15-34	3x AM77574MM	2x AM74299AFE	8x AM79487APG	1x AS-HWW15-10	1x AS-HWW15-57	12x AM76467AFE
1x AM75332APG	1x AS-HWW15-25	16x AM77574AFE	2x AM74299AFE	1x AM15485BLG	1x AS-HWW15-11	2x AM07590AFE	2x AM76276BDG
1x AS-HWW15-05	1x AS-HWW15-23	12x AM80120AFE	2x AM72244F	1x AM15485BLG	5x AM82100BDG	2x AM07590BDG	1x AM18740BDG
1x AM75332AFE	1x AS-HWW15-20	2x AM79665AFE	1x AM19392HT	4x AM01086AFE	1x AM82100AFE	2x AM07590BDG	1x AM18666BLG
1x AM77341APG	1x AS-HWW15-22	2x AM79590CV	1x AM79403ARD	15x AM07629AFE	1x AM82100F	4x AM73758BDG	1x AM18665BLG
32x AM77341ARC	3x AM03328BDG	2x AM79590CV	2x AM79403ANY	1x AM07629MM	4x AM80174BDG	4x AM73758ANY	1x AM18665BLG
8x AM77341BDG	11x AM03328F	15x AM79590AFE	2x AM79403ANY	7x AM18286MM	4x AS-HWW15-27	4x AM73758HT	8x AM09835AFE
8x AM77341F	11x AM03328AFE	4x AM79590MM	7x AM79403ARC	7x AM18286AFE	2x AS-HWW15-28	4x AM73758AFE	5x AM78189AFE
2x AM18560ARC	2x AM03328BLG	1x AM19999MM	3x AM79403HT	2x AM18286MM	1x AS-HWW15-16	8x AM09393BTN	1x AM82112AFE
1x AM18560APG	2x AM03328HT	2x AM19999APG	1x AM79403HT	1x AM17507BLG	1x AS-HWW15-24	6x AM09393BDG	1x AM82113AFE
1x AM18560WH	13x AM03328ASE	4x AM19530AFE	1x AM76867HT	1x AM17507BLG	1x AS-HWW15-21	1x AM09393APG	1x AM82113AFE
8x AM01113APG	8x AM07223AFE	2x AM19530MM	1x AM17506ARD	1x AM16679BDG	14x AM22501AFE	8x AM09393BLG	1x AM74427AFE
12x AM17003ARC	2x AM07223HT	2x AM17787AFE	1x AM17506ARC	1x AM16679BDG	2x AM22501BLG	28x AM09393AFE	1x AM74426AFE
2x AM17003HT	5x AM07223F	4x AM17787WH	2x AM74645ARC	1x AM17506ARC	4x AM22501BDG	3x AM09393HT	2x AM18272BDG
1x AM17003ARD	6x AM07223BLG	2x AM17127AFE	1x AM74645HT	1x AM17506ARC	3x AM79246F	3x AM03017WH	8x AM18549AFE
1x AM17003ANY	2x AM07223BDG	2x AM17127MM	1x AM74645HT	1x AM17506ARC	2x AM79246BMG	3x AM03017WH	4x AM18549BDG
1x AM74397APG	3x AM79666AYB	2x AM15258MM	2x AM81759BDG	2x AM01417BLG	1x AM79246AFE	3x AM81438F	
1x AM74397WH	2x AM81529WH		2x AM74415F				
1x AM75318X	1x AM76558BDG						

6x
AM80573AFE

4x
AM17128AFE

1x
AS-HWW15-17

1x
AS-HWW15-12

1x
AS-HWW15-13

2x
AM04430AFE

2x
AM17788AFE

1x
AS-HWW15-44

1x
AS-HWW15-43

1x
AM18601BDG

4x
AM09013BDG

7x
AM09013AFE

3x
AM17502BDG

7x
AM17502AFE

1x
AM81353NV

1x
AM81353FM

1x
AM81353AFE

4x
AM18667BDG

4x
AM18667AFE

2x
AS-HWW15-30

2x
AM04322APG

7x
AM04322AFE

1x
AM16972AFE

3x
AM74428AFE

1x
AM74428BMG

2x
AM74428BDG

2x
AM15484BLG

2x
AM15484BDG

10x
AM15484AFE

1x
AM15484APG

2x
AM17153AFE

4x
AM81473AFE

4x
AM80634AFE

2x
AM76525AFE

2x
AM74677BDG

3x
AM19380BDG

1x
AS-HWW15-04

1x
AS-HWW15-59

2x
AS-HWW15-64

1x
AM82107BLG

2x
AM82108BLG

4x
AM01320ARC

3x
AM72240AFE

1x
AM80832F

1x
AS-HWW15-19

1x
AM76762AAV

1x
AM81541AFE

1x
AM81542AFE

2x
AM74106AFE

2x
AS-HWW15-42

2x
AM08481AFE

4x
AM00948BLG

1x
AM0948AFE

2x
AM00948APG

2x
AM00948BDG

1x
AS-HWW15-37

2x
AM03773BLG

2x
AM03773HT

2x
AM03773AFE

2x
AM03773BTN

2x
AM03773WH

1x
AM73009AAV

2x
AM81988AFE

1x
AM81962BMG

4x
AM09267WH

2x
AM01146AFE

4x
AM01146BDG

4x
AM76450AFE

1x
AM76450F

2x
AM76450MM

1x
AM80940AFE

1x
AS-HWW15-54

1x
AM80966BMG

4x
AM80966BDG

1x
AM80966MM

5x
AM80966BLG

1x
AS-HWW15-58

6x
AM80966AFE

1x
AS-HWW15-33

1x
AM74103AWU

1x
AM72600F

6x
AM80143WH

1x
AM80143MM

4x
AM80143BDG

24x
AM01314AFE

2x
AM01314APG

2x
AM01314BLG

2x
AM01314MM

1x
AM01314BDG

1x
AM01314ZD

3x
AM01314WH

1x
AM01314BMG

2x
AM01314ASE

3x
AM74298AFE

9x
AM74298BDG

1x
AM81259APG

1x
AM81260NV

1x
AM81260FM

1x
AM79355F

4x
AM81986BDG

2x
AM76521APG

2x
AM74657ARC

1x
AM74657ARD

1x
AM77465BDG

3x
AM81639BDG

1x
AS-HWW15-46

3x
AM81639BLG

11x
AM81639AFE

1x
AS-HWW15-15

28x
AS-HWW15-26

3x
AM03772ASE

24x
AM03772AFE

1x
AM03772BDG

7x
AM74848BMG

5x
AM16384AFE

1x
AM16384BDG

16x
AM03873AFE

1x
AM03873BDG

2x
AM18775AFE

2x
AM18776AFE

1x
AM15479BDG

1x
AM15478BDG

2x
AM19323AFE

2x
AM80874F

2x
AM78472BLG

2x
AM76225F

1x AS-HWW15-18
 8x AM09838BDG
 1x AM09838AFE
 5x AM09838BLG
 1x AS-HWW15-36
 12x AM09838MCX
 1x AS-HWW15-31
 3x AM09593BTN
 2x AM09593APG
 4x AM09593BDG
 1x AM09593HT
 4x AM09593AFE
 2x AM09593BLG
 1x AM09593WH
 1x AM82118AFE

1x AS-HWW15-38
 8x AM18615AFE
 1x AS-HWW15-40
 1x AM18615BDG
 8x AM74139AFE
 1x AS-HWW15-39
 1x AM81163BTN
 22x AM81163AFE
 1x AM81163BDG
 2x AM81163APG
 5x AM72601BLG
 12x AM01087MCX
 3x AM01087AFE
 2x AM01087BLG

2x AM74416AFE
 1x AM03323APG
 5x AM03323AFE
 1x AM03324APG
 4x AM03324AFE
 3x AM09493BDG
 1x AM09493BTN
 4x AM09493AFE
 2x AM09493BLG
 2x AM77463BDG
 10x AM77463AFE
 1x AS-HWW15-45
 3x AM77321BLG
 3x AM77320BLG

1x AM79871BDG
 1x AM79871BMG
 2x AM01531BDG
 1x AM09033BDG
 2x AS-HWW15-01
 1x AS-HWW15-02
 1x AS-HWW15-03
 8x AM72025AFE
 1x AS-HWW15-49
 6x AM72025BDG
 2x AS-HWW15-29
 1x AS-HWW15-65
 4x AM78728AFE
 2x AS-HWW15-41

2x AM81561BDG
 2x AM07475ASE
 8x AM07475WH
 3x AM07475BDG
 10x AM07475AFE
 3x AM07475BLG
 2x AM17793AFE
 1x AS-HWW15-52
 1x AM17793BDG
 1x AS-HWW15-32
 1x AS-HWW15-55
 1x AM80965BLG
 18x AM80965AFE
 2x AM80965APG
 2x AM81294F

7x AM09292AFE
 1x AM09292APG
 2x AM09292BTN
 2x AM09292BLG
 2x AM09292HT
 1x AM16331AFE
 4x AM16331BLG
 1x AM16331HT
 2x AM16331MM
 1x AM16331APG
 1x AM01480BDG
 2x AM01480APG
 1x AS-HWW15-50
 2x AS-HWW15-09
 2x AM82117BDG
 3x AM82117AFE

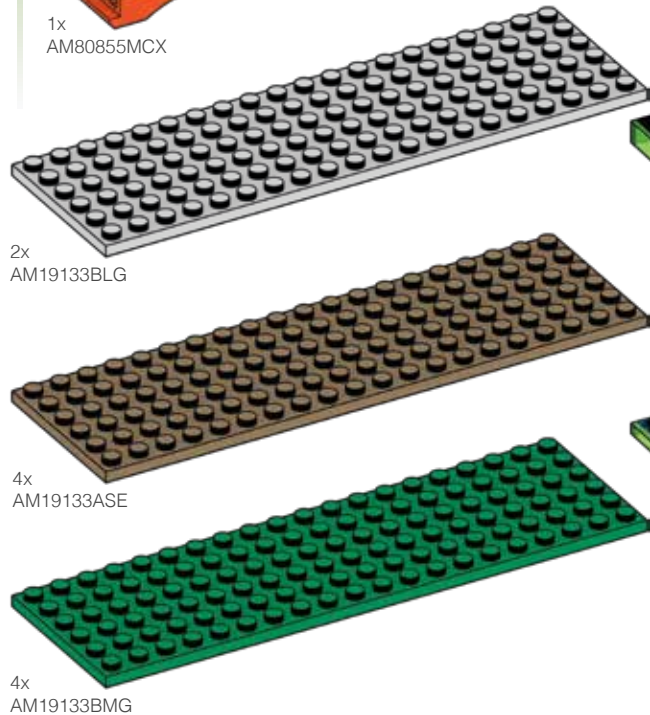
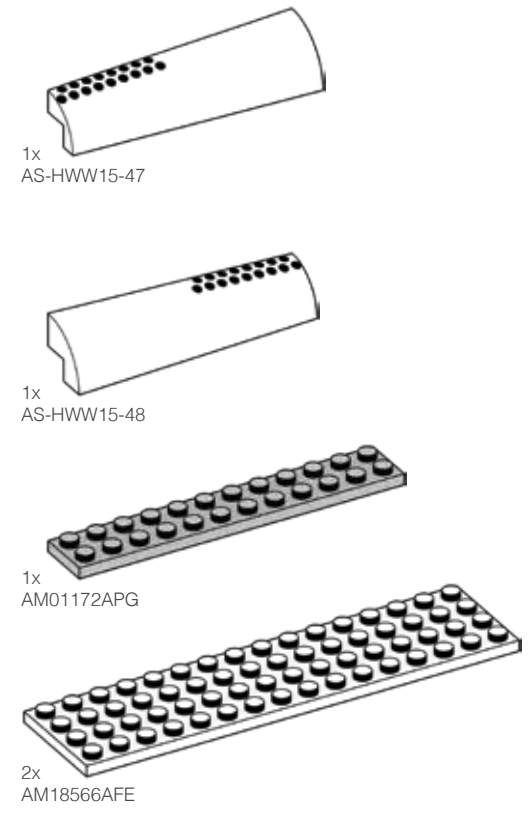
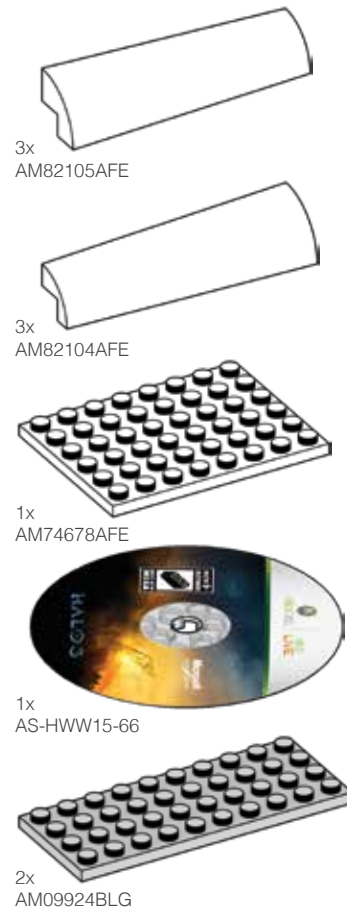
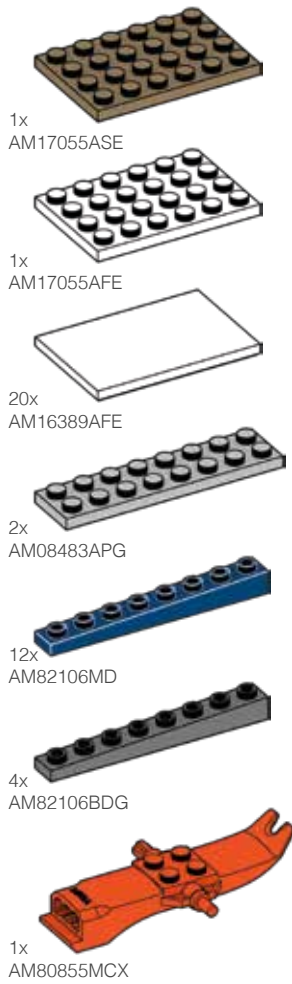
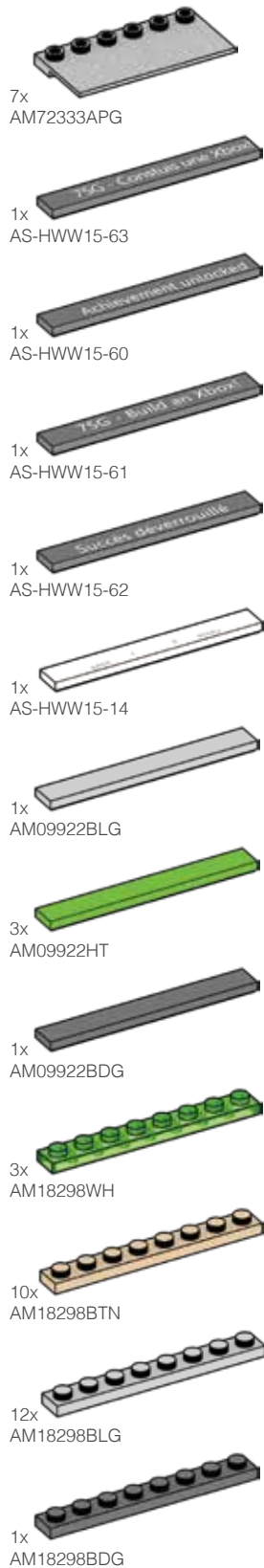

**Missing pieces?
Pièces manquantes?**
 ¿Partes faltantes? • Perdeu peças?
 Fehlen Teile? • Не хватает деталей?

support.megabrands.com

Please read these instructions carefully before first use and keep them for future reference.

Il est recommandé de lire attentivement ce feuillet avant la première utilisation et de le conserver pour référence future.

Leer estas instrucciones cuidadosamente antes de la primera utilización y guardarlas para referencia futura.

Leia as instruções antes do primeiro uso e guarde-as para futura referência.

Leggere le istruzioni prima di cominciare ad usare il gioco e conservarle per reference future.

Die Gebrauchsanleitung bitte durchlesen und aufbewahren.

Proszę uważnie przeczytać instrukcję obsługi przed pierwszym użyciem, a następnie zachować ją na przyszłość.

Wij raden u aan deze handleiding zorgvuldig te lezen en te bewaren voor eventuele raadpleging op een later tijdstip.

Внимательно прочитайте инструкцию перед первым использованием и сохраните ее для дальнейшего использования.

Vær venlig at læse disse instruktioner omhyggeligt inden ibrugtagten og opbevar dem til fremtidig brug.

Läs noggrant igenom dessa instruktioner innan du använder produkten för första gången och spara dem för ev framtidig frågor.

Les disse instruksjonene nøye før første gangs bruk, og ta vare på dem for fremtidige oppslag.

Lue nämä ohjeet huolellisesti ennen ensimmäistä käyttöä ja säilytä ne myöhempää tarvetta varten.

Διαβάστε προσεκτικά τις οδηγίες πριν από τη χρήση και κρατήστε τις για μελλοντική αναφορά.

Ilk kullannidan önce talimatları dikkatlice okumanızı ve bu bilgileri ileride tekrar bakabilmek için saklamanızı öneririz.

Před prvním použitím si pozorně přečtete pokyny a uschovejte je pro budoucí použití.

Před prvním použitím si pozorně přečtajte návod a uschovejte ho pre prípad potreby.

Olvasva el első használat előtt, és őrizze meg az útmutatót, mert a későbbiekben is felhasználható, fontos információkat tartalmaz.

初めてご使用になる前に、この説明書をよくお読みください。また、本書は将来いつでも参照できるように保管してください。

يجب قراءة هذه التعليمات بعناية قبل الاستخدام والاحتفاظ بها للعودة إليها مستقبلاً.

第一次使用前，请仔细阅读本说明书并保留以备将来参考。

BATTERY TYPE / TYPE DE PILES / TIPO DE PILA / TIPO DE PILHA / TIPO DI PILA / BATTERIETYP / TYP BATERII / BATTERIUTYPE / ТИП БАТАРЕЙКИ / BATTERIUTYPE / BATTERIUTYP / BATTERIUTYPE / PARISTOTYYPPI / ΤΥΠΟΣ ΜΠΑΤΑΡΙΑΣ / PİL TİPİ / TYP BATERÍI / TYP BATERIE / ELEM TÍPUSA / 電池の種類 / نوع البطاريات / 電池类型

Includes 12 alkaline, non-rechargeable, button cell batteries (AG3, LR41, 192 or equivalent). Dispose of batteries safely. / Contient 12 piles boutons alcalines non rechargeables (AG3, LR41, 192 ou équivalent). Jetez les piles usées dans un conteneur réservé à cet usage.

Incluye 12 pilas alcalinas de botón no recargables (AG3, LR41, 192 o equivalentes) x1,5V. Desecha las pilas gastadas en un contenedor de reciclaje de pilas.

Inclui 12 pilhas-botão alcalinas, não recarregáveis (AG3, LR41, 192 ou equivalentes). Colocar as pilhas gastas no pilhão.

Include 12 pile alcaline non ricaricabili formato bottone (AG3, LR41, 192 o equivalente). Smaltire le pile nel modo appropriato.

Enthält 12 nicht wiederaufladbare Alkali-Knopfzellen (AG3, LR41, 192 oder gleichwertig). Batterien sicher und vorschriftsgemäß entsorgen.

Zawiera 12 alkalicznych baterii guzikowych jednorazowego użytku (AG3, LR41, 192 lub odpowiednik). Zużyte baterie wyrzucić do odpowiednio oznaczonego pojemnika.

Inclusief 12 niet-oplaadbare alkaline-knopcelbatterijen (AG3, LR41, 192 of vergelijkbaar). Batterijen inleveren als KCA.

В комплект входят 12 щелочных, не перезаряжаемых батареек таблеточного типа (AG3, LR41, 192 или эквивалентного типа).

Утилизируйте батарейки безопасным способом.

Indeholder 12 alkaliske, ikke-genopladelige knapbatterier (AG3, LR41, 192 eller tilsvarende). Kassér batterierne på forsvarlig vis.

Innehåller 12 alkaliska, ej laddningsbara, knappcells batterier (AG3, LR41, 192 eller motsvarande). Släng batterierna på ett miljövänligt sätt.

Inneholder 12 alkaliske ikke-oppladbare knappcellebatterier (AG3, LR41, 192 eller tilsvarende). Kast batteriene på en forsvarlig måte.

Sisältää 12 ei-ladattavaa alkaliniipparistoa (AG3, LR41, 192 tai vastaavia). Hävitä paristot asianmukaisesti.

Περιλαμβάνονται 12 αλκαλικές, μη αναφορτιζόμενες μπαταρίες τύπου button cell (AG3, LR41, 192 ή παρόμοιου τύπου). Παρακαλούμε πετάτε τις παλιές μπαταρίες στους ειδικούς κάδους ανακύκλωσης.

12 adet alkali, şarj edilmeyen düğme pil (AG3, LR41, 192 veya muadili) ürüne dahildir. Pilleri güvenli bir şekilde atın.

Obsahuje 12 alkalických knoflíkových nedobjekcích baterií (AG3, LR41, 192 nebo ekvivalent). Baterie zlikvidujte ekologicky.

Obsahuje 12 alkalických nenabíjateľných gombíkových batérií (AG3, LR41, 192 alebo podobné). Batérie bezpečne zlikvidujte.

12 db nem újratölthető alkáli gombelemet tartalmaz (AG3, LR41, 192 vagy egyenértékű). A lemerült elemeket az azokra vonatkozó szabályozás szerint kezeljeze le.

アルカリボタン電池12個付属。使用済みの電池は、お住まいの自治体の指示に従って捨ててください。

تتضمن 12 بطارية طوية، قرصية غير قابلة للشحن (AG3, LR41, 192 أو ما يماثلها). يجب التخلص من البطاريات بشكل آمن.

包括 12 节不可充电碱性纽扣电池 (AG3, LR41, 192 或同等电池)。安全处置电池。

BATTERY INSTALLATION / INSTALLATION DES PILES / COLOCACIÓN DE LAS PILA / INSTALAÇÃO DAS PILHAS / COME INSERIRE LE PILE / EINLEGEN UND AUSWECHSELN DER BATTERIEN / WKŁADANIE BATERII / HET PLAATSSEN VAN DE BATTERIJEN / УСТАНОВКА БАТАРЕЕК / ISÆTNING AF BATTERIER / BATTERIINSTALLATION / INNSÆTNING AV BATTERIER / PARISTOJEN ASENNUS / ΤΟΠΟΘΕΤΗΣΗ ΜΠΑΤΑΡΙΑΩΝ / PILLERIN YERLEŞTİRİLMESİ / VLOŽENÍ BATERÍI / INSTALÁCIA BATÉRII / AZ ELEM EK BEHELYEZÉSE / 電池の入れ方 / تركيب البطاريات

BATTERY INSTALLATION

Use a phillips (star-bit) screwdriver to unscrew the door of the battery compartment.

Lift and remove the compartment door.

Insert the batteries according to the correct polarity shown.

Replace the door and the screws, do not over-tighten the screws.

INSTALLATION DES PILES

Dévisser le couvercle du compartiment à piles avec un tournevis cruciforme.

Soulever et retirer le couvercle du compartiment à piles.

Insérer les piles en respectant la polarité indiquée.

Replacer le couvercle et les vis, et revisser sans forcer.

COLOCACIÓN DE LAS PILAS

Desatornillar la tapa del compartimento de las pilas con un destornillador de estrella y retirarla.

Colocar las pilas en el compartimento, según la polaridad indicada.

Volver a colocar y atornillar la tapa, sin apretarla demasiado.

INSTALAÇÃO DAS PILHAS

Usar uma chave de estrela para desaparafusar a tampa do compartimento de pilhas.

Levantar e retirar a tampa do compartimento de pilhas.

Inserir as pilhas de acordo com a posição das polaridades mostrada.

Colocar a tampa e o parafuso, e não apertar demasiado o parafuso.

COME INSERIRE LE PILE

Aprire lo sportello dello scomparto pile con un cacciavite a stella.

Sollevar e rimuovere lo sportello dello scomparto pile.

Inserire le pile rispettando le polarità indicate.

Rimettere lo sportello e stringere la vite senza forzare.

EINLEGEN UND AUSWECHSELN DER BATTERIEN

Die Batteriefachabdeckung mit einem Kreuzschlitzschraubenzieher aufschrauben.

Die Batteriefachabdeckung anheben und abnehmen.

Die Batterien in die im Batteriefach angegebene Polrichtung (+/-) einlegen.

Die Batteriefachabdeckung und die Schrauben wieder einsetzen, und die Schrauben festziehen.

Die Schrauben nicht zu fest anziehen, damit sie nicht überdrehen.

WKŁADANIE BATERII

Odkreć pokrywę przedziału na baterie za pomocą śrubokręta krzyżkowego.

Podnieś i zdejmij pokrywę przedziału.

Włóż baterie zgodnie z oznaczeniami biegunów.

Załóż pokrywę i dokreć śruby. Nie dokrećaj zbyt mocno.

HET PLAATSSEN VAN DE BATTERIJEN

Schroef met een kruisopschroevendraaier het klepje van de batterijhouder los.

Leg het klepje even apart.

Zet de batterijen in de houder met de plus- en minpolen zoals afgebeeld.

Zet het klepje terug en draai de schroef vast. Niet te strak vastdraaien.

УСТАНОВКА БАТАРЕЕК

Используйте крестообразную отвертку, чтобы отвинтить крышку батарейного отсека.

Снимите крышку батарейного отсека.

Вставьте батарейки, соблюдая полярность.

Поставьте крышку батарейного отсека на место и закрутите винты. Не закручивайте слишком плотно.

ISÆTNING AF BATTERIER

Brug en stjerneskruejern til at skruе dækslet til batterirummet af.

Løft dækslet af.

Sæt batterierne i, og sørg for, at deres poler vender rigtigt.

Sæt dækslet på igen, og spænd skruen fast. Pas på ikke at spænde den for hårdt.

BATTERIINSTALLATION

Använd en stjärnskrummejsel för att skruva loss batteriluckan.

Lyft och ta bort luckan.

Sätt i batterierna med polerna åt rätt håll som visas på bilden.

Sätt tillbaka luckan och skruva fast skruvarna, men inte för hårt.

INNSÆTNING AV BATTERIER

Bruk et stjerneskruejern til å løsne dekslet på batterirummet.

Løft opp og ta av dekslet.

Sett inn batteriet med riktig polaritet.

Sett på dekslet og skru det fast, men ikke stram for hardt.

PARISTOJEN ASENNUS

Avaa paristokotelon kannen ruuvi ristipäämeissellä.

Nosta kansi irti.

Aseta paristo koteloon merkkien (+/-) mukaisesti.

Aseta kansi paikalleen ja kiristä ruuvi. Älä kiristä ruuvia liikaa.

ΤΟΠΟΘΕΤΗΣΗ ΜΠΑΤΑΡΙΑΩΝ

Χρησιμοποιήστε ένα σταυροκατάβιδο για να ξεβιδώσετε το πορτάκι της θήκης των μπαταριών

Σηκώστε και αφαιρέστε το πορτάκι της θήκης των μπαταριών.

Τοποθετήστε τις μπαταρίες μέσα στη θήκη της, όπως απεικονίζεται.

Κλείστε το πορτάκι της θήκης των μπαταριών και σφίξτε τη βίδα.

PILLERIN YERLEŞTİRİLMESİ

Yıldız tornavidayla pil bölümlerinin kapağınıdaki vidayı gevşetin.

Pil bölümlerinin kapağını kaldırın ve çıkarın.

Pilleri gösterilen şekilde doğru kutuplara göre yerleştirin.

Kapağı yerine yerleştirip vidalarını takın. Vidaları çok fazla sıkmayın.

VLOŽENÍ BATERÍI

Odsroubujte kryt prostoru pro baterie pomocí křížového

šroubováku.

Odklopte a sundejte kryt prostoru pro baterie.

Vložte baterie podle správné polaritý znázorněné uvnitř.

Vraťte zpět kryt prostoru pro baterie a šroubky. Šroubky při utahování nepřetahujte.

INSTALÁCIA BATÉRII

Na odskrutkovanie krytu priestoru pre batérie použite krížový skrutkovač.

Zdvihnutím vyberte kryt priestoru pre batérie.

Vložte batérie tak, aby ste dodržali spránu znázornenú polaritú.

Vraťte kryt priestoru pre batérie a skrutky na miesto, pričom skrutky nadmerne nedotahujte.

AZ ELEM EK BEHELYEZÉSE

Csavarozza le az elemtartó rekesz fedelét egy csillagszavar-

húzó segítségével.

Emelje meg és távolítsa el a rekesz fedelét.

Az elemek behelyezésekor ügyeljen a megfelelő polaritásra.

Helyezze vissza a fedelet és a csavarokat. Ne húzza meg túl erősen a csavarokat.

池の入れ方

プラスのドライバーを使って電池ケースのふたのネジをゆるめ、ふたをあげてください。新しい電池を正しくセットしてください。ふたをもどしたら、ドライバーでしめてください。ネジのしめすぎにご注意ください。

تركيب البطاريات

يجب استخدام مفك براغي (نجمي الرأس)

من نوع phillips لفك براغي غطاء حجرة

البطاريات.

يجب رفع غطاء حجرة البطاريات ونزع

عنه. يجب وضع البطاريات باتجاه الأقطاب الصحيح، كما هو مبين.

يجب إعادة غطاء حجرة البطاريات والبراعي. يجب عدم المبالغة في شدّ

البراعي.

電池安裝

使用十字（星状）螺丝刀旋开电池仓的螺丝。

提起并卸除电池盖。

按照说明中正负极方向装入电池。

将电池盖和螺丝按原来的方式装回，不要过分拧紧螺丝。

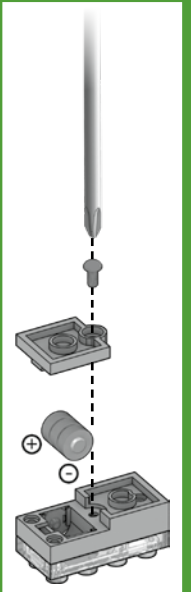

BATTERY SAFETY INFORMATION / MISES EN GARDE AU SUJET DES PILES / INFORMACIÓN DE SEGURIDAD ACERCA DE LAS PILAS / INFORMAÇÕES DE SEGURANÇA SOBRE PILHAS / NORME DI SICUREZZA PER LE PILE / BATTERIESICHERHEITSHINWEISE / INFORMACJE DOTYCZĄCE BEZPIECZNEGO KORZYSTANIA Z BATERII / BATTERI-INFORMATIE / ИНФОРМАЦИЯ ПО БЕЗОПАСНОМУ ОБРАЩЕНИЮ С БАТАРЕЙКАМИ / INFORMATION OM SIKKER BRUG AF BATTERIER / BATTERIINFORMATION / SIKKERHETSINFORMASJON OM BATTERIENE / YLEISIÄ OHJEITA PARISTOJEN JA AKKUJEN TURVALLISESTA KÄYTÖSTÄ / ΠΛΗΡΟΦΟΡΙΕΣ ΓΙΑ ΤΙΣ ΜΠΑΤΑΡΙΕΣ / PIL GÜVENLİĞİ BİLGİLERİ / 電池安全注意信息 / معلومات عن البطاريات والسلامة / 電池についてのご注意



WARNING: Button cell batteries are hazardous. Button cell batteries can cause serious injuries if swallowed or placed inside any part of the body. Keep new and used batteries away from children. Dispose of used batteries immediately. If you think batteries might have been swallowed or placed inside any part of the body, seek immediate medical attention

ADVERTENCIA: Las pilas de botón son peligrosas. Las pilas de botón pueden causar graves lesiones si se ingieren o se introducen en cualquier parte del cuerpo. Mantén las pilas (tanto las nuevas como las usadas) lejos del alcance de los niños. Desecha las pilas gastadas inmediatamente. Si sospechas que el niño se ha tragado una pila o se la ha introducido en alguna parte del cuerpo, acude inmediatamente a un médico.

ATTENTION : LES PILES BOUTONS SONT DANGEREUSES. LES PILES BOUTONS PEUVENT CAUSER DE GRAVES BLESSURES SI ELLES SONT AVALÉES OU PLACÉES À L'INTÉRIEUR D'UNE PARTIE DU CORPS. TENEZ LES PILES NEUVES ET USÉES HORS DE PORTÉE DES ENFANTS. JETEZ LES PILES USÉES IMMÉDIATEMENT. SI VOUS PENSEZ QU'UNE OU PLUSIEURS PILES ONT PU ÊTRE AVALÉES OU PLACÉES À L'INTÉRIEUR D'UNE PARTIE DU CORPS, CONSULTEZ IMMÉDIATEMENT UN MÉDECIN.

ATENÇÃO! AS PILHAS-BOTÃO SÃO PERIGOSAS. AS PILHAS-BOTÃO PODEM CAUSAR FERIMENTOS GRAVES SE ENGOLIDAS OU COLOCADAS NO INTERIOR DE UMA PARTE DO CORPO. MANTER PILHAS NOVAS E USADAS FORA DO ALCANCE DAS CRIANÇAS. ELIMINAR PILHAS USADAS DE IMEDIATO. SE SUSPEITAR QUE UMA PILHA PODERÁ TER SIDO ENGOLIDA OU COLOCADA NO INTERIOR DE UMA PARTE DO CORPO, CONSULTAR UM MÉDICO DE IMEDIATO.

AVVERTENZA: Le pile formato bottone sono pericolose. Le pile formato bottone possono causare gravi lesioni se ingerite o inserite in qualunque parte del corpo. Tenere i bambini lontano da pile nuove e usate. Eliminare immediatamente le pile usate. Contattare immediatamente un medico nel caso in cui si avesse il sospetto che le pile siano state ingerite o inserite in qualunque parte del corpo.

ACHTUNG: Knopfzellen sind gefährlich. Knopfzellen können schwere Verletzungen verursachen, wenn sie verschluckt werden oder auf anderem Weg ins Körperinnere gelangen. Neue und verbrauchte Batterien außer Reichweite von Kindern aufbewahren. Verbrauchte Batterien sofort sicher und vorschriftsgemäß entsorgen. Suchen Sie sofort einen Arzt auf, falls Sie annehmen, dass Batterien verschluckt wurden oder auf anderem Weg ins Körperinnere gelangt sind.

OSTRZEŻENIE: Baterie guzikowe mogą stwarzać zagrożenie. Baterie guzikowe mogą być przyczyną poważnych obrażeń, jeśli zostaną połknięte lub znajdą się wewnątrz dowolnej części ciała. Przechowuj nowe i zużyte baterie poza zasięgiem dzieci. Zużyte baterie niezwłocznie wyrzuć do odpowiednio oznaczonego pojemnika. Jeśli podejrzewasz, że bateria/e mogła/y zostać połknięta/e lub w jakikolwiek inny sposób wprowadzona/e do ciała, natychmiast zgłoś się do lekarza.

WAARSCHUWING: Knopcelbatterijen zijn gevaarlijk. Knopcelbatterijen kunnen ernstig letsel veroorzaken bij inslikken of wanneer ze in een lichaamsholte worden gestopt. Nieuwe en gebruikte batterijen uit de buurt houden van kinderen. Oude batterijen meteen weggoeien. Als je denkt dat de batterijen mogelijk zijn ingeslikt of vastzitten in een lichaamsholte, moet je onmiddellijk medische hulp inroepen.

ОСТОРОЖНО: Батарейки таблеточного типа являются опасными. Батарейки таблеточного типа могут стать причиной серьезных травм при проглатывании или помещении внутрь любой части тела. Храните новые и использованные батарейки в недоступном для детей месте. Утилизируйте использованные батарейки немедленно. Если вы предполагаете, что батарейки были проглочены или помещены внутрь любой части тела, обратитесь за медицинской помощью немедленно.

ADVARSEL: Knappcellebatterier er farlige. Knappcellebatterier kan forårsage alvorlige skader, hvis de sluges eller på anden måde er kommet ind i kroppen. Opbevar nye og brugte batterier uden for børns rækkevidde. Bortskaf brugte batterier øjeblikkeligt. Hvis du tror at et batteri er blevet slugt eller på anden måde er kommet ind i kroppen, skal du søge lægehjælp øjeblikkeligt.

WARNING: Knappcells batterier kan vara farliga. Knappcells batterier kan orsaka allvarliga skador om man sväljer eller på annat sätt får i sig dem. Håll nya och använda batterier borta från barn. Kasta använda batterier omedelbart. Om du tror att någon har sväljt eller fått i sig batterier, sök läkarhjälp omedelbart.

ADVARSEL: Knappcellebatterier er farlige. Knappcellebatterier kan forårsake alvorlige personskader om de svelges eller befinner seg i en kroppsdell. Nye og brukte batterier må holdes unna barn. Kast batterier som er brukt, umiddelbart. Hvis du mistenker at batterier kan ha blitt svelget eller befinner seg i en kroppsdell, må du øyeblikkelig kontakte lege.

VAROITUS: Nappiparistot ovat vaarallisia. Nielytä niitä minikä tahansa kehonosan sisälle joutunut

nappiparistot voi aiheuttaa vakavia vammoja. Pidä uudet ja käytetyt paristot pois lasten ulottuvilta. Hävitä käytetyt paristot välittömästi. Jos epäilet, että paristo on joutunut nieluun tai minikä tahansa kehonosan sisälle, hakeudu välittömästi lääkärin hoitoon.

ΠΡΟΣΟΧΗ: Οι μπαταρίες button cell είναι επικίνδυνες. Οι μπαταρίες button cell μπορεί να προκαλέσουν σοβαρούς τραυματισμούς κατάποσης ή τοποθέτησης μέσα σε οποιοδήποτε μέρος του σώματος. Κρατήστε τις νέες και τις χρησιμοποιούμενες μπαταρίες μακριά από τα παιδιά. Πελάξτε τις χρησιμοποιούμενες μπαταρίες αμέσως. Ζητήστε αμέσως ιατρική βοήθεια σε περίπτωση κατάποσης της μπαταρίας.

UVARI: Dúgme piller tehlikeldid. Dúgme piller, yutulmasi veya vücudun herhangi bir yerine yerleştirilmesi durumunda ciddi yaralanmalara neden olabilir. Yeni ve kullanılmış pilleri çocuklardan uzak tutun. Kullanılan pilleri derhal atın. Pillerin yutulduğuna veya vücudun almindığı dışünüyöransız derhal tibbi yardım alın.

UPOZORNĚNÍ: Knoflíkové baterie mohou představovat nebezpečí. Knoflíkové baterie mohou způsobit závažná poranění pokud dojde k jejich spolknutí či jejich vlození do jiných částí těla. Nové i použité baterie uchovávejte mimo dosah dětí. Použité baterie okamžitě zlikvidujte. Pokud máte podezření, že došlo ke spolknutí baterií či jejich vlození do jiných částí těla, vyhledejte ihned lékařskou pomoc.

UPOZORNENIE: Gombíkové batérie sú nebezpečné. Gombíkové batérie môžu po požití alebo vložení do kotrekoľvek časti tela spôsobiť závažné zranenia. Nové aj použité batérie uchovávajte mimo dosahu detí. Použité batérie ihneď zlikvidujte. Ak máte podozrenie, že došlo k prehltnutiu batérií či ich vloženiu do iných častí tela, vyhľadajte ihneď lekársku pomoc.

FIGYELMEZTETÉS: A gombelemek veszélyesek. A gombelemek lenyelése vagy a test bármely részébe helyezése súlyos sérüléseket okozhat. Az új és használt elemek gyermekek elől elzárva tartandók. A használt elemeket azonnal sejtjezzék le. Ha oka van feltételezni, hogy egy elemet lenyeltek vagy bármilyen módon a testbe kerültek, azonnal forduljon orvoshoz.

危険 (きけん) 保護者の方へ 必ずお読みください。 この商品はボタン電池を使用します。ボタン電池を飲み込んだり、鼻の穴など体の一部に入れたりすると、重篤化し最悪の場合は死に至るおそれがあります。未使用または使用済みの電池は、絶対にお子さまの届かない場所に保管してください。使用済みの電池はすぐに処分してください。方が、電池を飲み込んだり、体の一部に入れてしまった可能性がある場合は、すぐに医師に相談してください。

تحذير: البطاريات الفورية خطيرة. قد تنتسب البطاريات الفورية بحوادث إصابات خطيرة أو البقع أو إذا تم وضعها داخل أي جزء من الجسم. يجب إلقاء البطاريات الجديدة والمستهلكة بعيداً عن متناول الأطفال. يجب التخلص من البطاريات المستهلكة في الحال. إذا ظننت أنه قد تم ابتلاع البطاريات أو تم وضعها في أي جزء من الجسم، يجب طلب الرعاية الصحية فوراً.

警告：纽扣电池含有害物质。若不慎吞入或使纽扣电池进入任一身体部位，可能会对身体造成严重伤害。请妥善保管新旧电池，使它们远离儿童视线。电池报废后请立即处理。若不慎吞入电池或使电池进入任一身体部位，请立即就医。

PROPER DISPOSAL / MISE AU REBUT APPROPRIÉE / DESECHAR CORRECTAMENTE / ELIMINAÇÃO ADEQUADA / ELIMINAZIONE CORRETTA / KORREKTE ENTSORGUNG / WŁĄCZIWA UTYLIZACJA / INLEVEREN VAN BATTERIËN / НАДЛЕЖАЩАЯ УТИЛИЗАЦИЯ / KORREKT BORTSKAFFELSE / KORREKT AVFALLSHANTERING / AVFALLSHÄNDTERING / ASIANNUKAINEN HÄVITTÄMINEN / ΕΝΑΠΟΘΕΣΗ ΜΠΑΤΑΡΙΩΝ / DOGRU ŞEKİLDE İMHA ETME / ŘÁDNÁ LKVIDACE / SPRÁVNA LKVIDÁCIA / MEGFELELŐ ÁRTALMATLANÍTÁS / 廃棄について / التخلص السليم /



Protect the environment by not disposing of this product or any batteries with household waste. This symbol indicates that this product shall not be treated as household waste. Check your local authority for recycling advice and facilities. / Protégez l'environnement en ne jetant pas ce produit et tout type de piles avec les ordures ménagères. Ce symbole indique que ce produit ne doit pas être jeté avec les ordures ménagères. Consultez la municipalité pour obtenir des conseils sur le recyclage et connaître les centres de la région. / Ayúdenos a proteger el medio ambiente y no tire este producto ni las baterías a la basura doméstica. Este símbolo indica que el producto no debe ser tratado como basura doméstica. Para más información sobre la eliminación correcta de residuos, póngase en contacto con la junta de residuos o el ayuntamiento de su localidad. / Proteger o ambiente – não colocar este produto nem nenhuma pilha no lixo doméstico. Este símbolo indica que este produto não deverá ser tratado como lixo doméstico. Para mais informações sobre conselhos de reciclagem e locais de recolha de lixo, consulte os organismos locais responsáveis. / Per proteggere l'ambiente non smaltire questo prodotto con i normali rifiuti domestici. Questo simbolo indica che il prodotto non rientra nella categoria dei rifiuti domestici. Rivolgersi alle autorità locali competenti per i consigli

sul riciclaggio e sulle relative strutture di smaltimento. / Schützen Sie die Umwelt, indem Sie dieses Produkt und/oder dazugehörige Batterien nicht in den Hausmüll geben. Dieses Symbol bedeutet, dass das Produkt nicht über den Hausmüll entsorgt werden darf. Wenden Sie sich bitte hinsichtlich der Entsorgung und Informationen zu öffentlichen Rücknahmestellen an die zuständigen Behörden. / Chroní srodovisko! Nie wyrzucaj tego produktu ani żadnych baterii razem z odpadami gospodarstwa domowego. Ten symbol oznacza, że produkt nie powinien być traktowany jak odpad z gospodarstwa domowego. Dowiedz się od lokalnych władz, jakie są możliwości recyklingu w Twojej okolicy. / Denk aan het milieu en zet dit product of de batterijen niet bij het huishoudafval. Dit symbool geeft aan dat het product niet bij het huishoudafval mag worden gezet. Win advies in bij jouw gemeente en informeer naar faciliteiten voor recycling. / Защитите окружающую среду, утилизирував данное изделие и батарейки отдельно от бытовых отходов. Этот символ означает, что данный продукт не утилизируется как бытовые отходы. Узнайте у местных властей о правилах и пунктах утилизации. / Beskyt miljøet ved ikke at smide dette produkt ud sammen med husholdningsaffald. Symbolet angiver, at dette produkt ikke må behandles som husholdningsaffald. Kontakt de lokale myndigheder for oplysninger om genbrugsordning. / Skydda miljön och släng inte den här produkten eller några batterier med hushållsavfallet. Den här symbolen indikerar att produkten inte ska hanteras som hushållsavfall. Kontakta din lokala myndighet för information om återvinning. / Ta vare på miljøet ved ikke å kaste dette produktet eller batterier som vanlig restavfall. Dette symbolet viser at produktet ikke skal behandles som vanlig restavfall. Kontakt de lokale myndighetene for å få tips om resirkulering. / Suojele ympäristöä: älä hävittää tuotetta tai paristoja talousjätteen mukana. Tämä symboli osoittaa, että tätä tuotetta ei saa käsitellä talousjätteenä. Kierrätystä ja kierrätyspalveluja koskevia ohjeita saa paikallisviranomaisilta. / Προστατέψτε το περιβάλλον. Μην αναποθέτετε το προϊόν ή τις μπαταρίες με απόβλητα οικιακής προέλευσης.

Autó to σύμβολο υποδεικνύει ότι δεν πρέπει να μεταχειρίζεστε το προϊόν ως απόβλητο οικιακής προέλευσης. Συμβουλευτείτε την κατά τόπο αρμόδια αρχή για περισσότερες οδηγίες και πληροφορίες για την ανακύκλωση. / Çevreyi korumak için bu ürünü ve hiçbir pilli evsel atıklanınızla birlikte çöpe atmayın. Bu işaret, ürünü evsel atık olmadığınız gösterir. Geri dönüşüm önerileri ve tesisleri için bölgenizdeki yetkililere danışın. / Čraňte životní prostředí a nevyhazujte tento výrobek ani baterie do domovního odpadu. Tento symbol znamená, že s tímto výrobkem nemá být zacházeno jako s domácím odpadem. Informace o recyklování a sběrnách vám poskytnou příslušné správní úřady. / Čraňte životné prostredie a nevhazujte tento výrobok, ani batérie do domáceho odpadu. Tento symbol znamená, že s týmto výrobkom sa nemá zaobchádzať ako s komunálnym odpadom. Odporúčania týkajúce sa recyklácie a informácie o zariadeniach na recykláciu vám poskytne miestny úrad. / Övja a környezetet! A termékét és az elemeket a háztartási hulladéktól elkülönítve sejtjezzék le. A szimbólum azt jelenti, hogy a termék nem kezelhető háztartási hulladékként. Forduljon a helyi hatóságokhoz, ahol hulladék-újrahasznosítási tanácsokat kaphat, és tájékozódhat az újrahasznosítható hulladékok gyűjtő helyekről. / 商品や電池の廃棄については、お住まいの自治体の指示に従って、商品についてのマークを参考に捨ててください。 / يجب المساهمة في الحفاظ على البيئة بعدم التخلص من هذا المنتج أو أي من البطاريات من خلال رميه في القمامة المنزلية. يسير هذا الرمز إلى أنه لا يجب رمي هذا المنتج في القمامة المنزلية. يجب استشارة الجهات المعنية حول طرق إعادة التدوير والرافاق المعدة لذلك. / 为了保护环境，请勿将本产品或任何电池和生活垃圾混合丢弃。此符号表示不得将该产品作为家庭垃圾进行处理。请您查询当地回收建议和设施。

BATTERY SAFETY INFORMATION / MISES EN GARDE AU SUJET DES PILES / INFORMACIÓN DE SEGURIDAD ACERCA DE LAS PILAS / INFORMAÇÃO IMPORTANTE SOBRE PILHAS / NORME DI SICUREZZA PER LE PILE / BATTERIESICHERHEITSHINWEISE / INFORMACJE DOTYCZĄCE BEZPIECZNEJ KOROZYJANIA Z BATERII / BATTERIJ-INFORMATIE / ИНФОРМАЦИЯ ПО ТЕХНИКЕ БЕЗОПАСНОСТИ БАТАРЕЙ / INFORMATION OM SIKKER BRUG AF BATTERIER / BATTERIINFORMATION / SIKKERHETSINFORMASJON OM BATTERIENE / YLEISIÄ OHJEITA PARISTOJEN JA AKKUJEN TURVALLISESTA KÄYTTÖSTÄ / ΠΑΡΗΦΟΡΕΙΣ ΓΙΑ ΤΙΣ ΜΠΑΤΑΡΙΕΣ / PIL GÜVENLİĞİ BİLGİLERİ / BEZPEČNOSTNÍ INFORMACE O BATERIÍCH / BEZPEČNOSTNÉ INFORMÁCIE O BATERIÁCH / AZ ELEMEK BIZTONSÁGARA VONATKOZÓ INFORMÁCIÓK / 電池についてのご注意 / 電池安全注意信息 / معلومات عن البطاريات

و السلامة معلومات عن سلامة البطريات

da sostanze chimiche o danneggiare il giocattolo. Per prevenire le perdite di liquido:
• Non ricaricare pile non ricaricabili.
• Estrarre le pile ricaricabili dal giocattolo prima della ricarica.
• Ricaricare le pile ricaricabili removibili solo sotto la supervisione di un adulto.
• Non mischiare pile alcaline, standard (zinco-carbone) o ricaricabili.
• Non mischiare pile vecchie e nuove.
• Usare solo pile dello stesso tipo o equivalenti, come raccomandato.
• Le pile devono essere inserite rispettando la corretta polarità (+ e -).
• Estrarre le pile scariche dal giocattolo.
• Non cortocircuitare mai i terminali delle pile.
• Eliminare le pile con la dovuta cautela.
• Non gettare le pile nel fuoco. Potrebbero esplodere o presentare perdite di liquido.

In Ausnahmefällen können Batterien auslaufen, Die auslaufende Flüssigkeit kann Verbrennungen verursachen oder das Produkt zerstören. Um ein Auslaufen von Batterien zu vermeiden, beachten Sie bitte folgende Hinweise:
• Niemals Alkali-Batterien, Standardbatterien (Kohle-Zink) oder wiederaufladbare Batterien miteinander kombinieren.
• Niemals alte und neue Batterien zusammen einlegen. Immer alle Batterien zur gleichen Zeit auswechseln.
• Darauf achten, dass die Batterien in der richtigen Polrichtung (+/-) eingelegt sind.
• Die Batterien immer herausnehmen, wenn das Produkt längere Zeit nicht benutzt wird.
• Alte oder verbrauchte Batterien immer aus dem Produkt entfernen.
• Batterien zum Entsorgen nicht ins Feuer werfen, da die Batterien explodieren oder auslaufen können.
• Die Anschlussklemmen dürfen nicht kurzgeschlossen werden.
• Nur Batterien desselben oder eines entsprechenden Batterietyps wie empfohlen verwenden.
• Nicht wiederaufladbare Batterien dürfen nicht aufgeladen werden.
• Wiederaufladbare Batterien vor dem Aufladen immer aus dem Produkt herausnehmen.
• Das Aufladen wiederaufladbarer Batterien darf nur unter Aufsicht eines Erwachsenen durchgeführt werden.
• Batterien sicher und vorschriftsgemäß entsorgen.

Wyjątkowych okolicznościach baterie mogą się rozlać, co może spowodować oparzenia chemiczne lub zniszczyć ten produkt. Aby uniknąć wycieków z baterii, postępuj zgodnie z poniższymi zaleceniami:
• Nie łądaj ponownie baterii jednorazowego użytku.
• Przed ładowaniem akumulatorów wyjmij jez produktu.
• Akumulatory można ładować jedynie pod nadzorem osoby dorosłej.
• Nie mieszaj ze sobą baterii alkalicznych, standardowych (cyńkowo-węglowych) oraz akumulatorów.
• Nie stosuj jednocześnie baterii starych i nowych.
• Stosuj wyłącznie baterie tego samego typu lub ich odpowiedniki, zgodnie z zaleceniami.
• Baterie wkładaj zgodnie z oznaczeniami biegunów (+ oraz -).
• Zawsze wyjmij zużyte baterie z produktu.
• Nie wlewjaz zaciśków zasilańa.
• Zużyte baterie wyrzucaj do odpowiednio oznaczonego pojemnika.
• Nie wyrzucaj tego produktu do ognia. Baterie wewnątrz zabawki mogą wybuchnąć lub wycieknąć.

In uitzonderlijke omstandigheden kan uit batterijen vloeistof lekken die brandwonden kan veroorzaken of het product onherstelbaar kan beschadigen. Om batterijlekkage te voorkomen:
• Nooit batterijen van een verschillend type bij elkaar gebruiken; alkaline-, standaard (koolstof-zink) of oplaadbare batterijen.
• Plaats de batterijen zoals aangegeven in de batterijhouder.
• Batterijen uit het product verwijderen wanneer het langere tijd niet wordt gebruikt.
• Lege batterijen altijd uit het product verwijderen.
• Batterijen inleveren als KCA.
• Batterijen niet in het vuur gooien; de batterijen kunnen dan ontpluffen of gaan lekken.
• Zorg ervoor dat er geen kortsluiting bij de batterijpolen ontstaat.
• Batterijen moeten worden geplaast met de juiste polariteit (+ en -).
• Niet-oplaadbare batterijen mogen niet worden opgeladen.
• Als er uitneembare oplaadbare batterijen worden gebruikt, de batterijen uit het product verwijderen voordat ze worden opgeladen.
• Als er uitneembare oplaadbare batterijen worden gebruikt, mogen die alleen onder toezicht van een volwassene worden opgeladen.

В исключительных случаях батарейки могут дать течь, что может привести к химическим ожогам или повредить игрушку. Чтобы избежать протекания батареек необходимо сделать следующее:
Не следует пытаться перезарядить неаккумуляторные батарейки.
• Перезаряжаемые батарейки перед зарядкой необходимо вынуть из устройства.
• Перезаряжаемые батарейки следует перезаряжать только под присмотром взрослых.
• Не используйте одновременно щелочные, стандартные (угольно-цинковые) или перезаряжаемые батарейки.
• Не смешивайте старые и новые батарейки.
• Рекомендуется использовать только батарейки того же или эквивалентного типа.
• Батарейки необходимо вставить, соблюдая полярность (+ и -).
• Израсходованные батарейки необходимо вынуть из изделия.
• Зажимы подключения источника питания нельзя подвергать короткому замыканию.
• Утилизируйте батарейку (ки) безопасным образом.
• Не выбрасывайте изделие в огонь. Имеющиеся внутри него батарейки могут взорваться или потечь.

I sjældne tilfælde kan batterier lække væske, som kan sætte huden eller ødelægge produktet. Sådan undgår du batterilekkage:
• Bland ikke alkaliske batterier, almindelige batterier (kul-zink) og genopladelige batterier.
• Læg batterierne i som vist i batterierummet.
• Tag batterierne ud, hvis produktet ikke skal bruges i længere tid.
• Fjern altid brugte batterier fra produktet.
• Bland ikke nye og gamle batterier.
• Sørg for, at batteriernes poler vender rigtigt (+ og -).
• Produktet må ikke brændes, da batterierne kan eksplodere eller lække.
• Batteriernes poler må aldrig kortslutes.
• Brug kun batterier af samme eller tilsvarende type som dem, der anbefales.
• Genopladelige batterier skal tages ud af produktet, før de oplades.
• Hvis der bruges udtagedige, genopladelige batterier, må de kun oplades under opsyn af en voksen.

I undantagsfall kan batterierna läcka vätska som kan orsaka frätskador eller förstöra leksaken. Undvik batteriläckage:
• Icke uppladdningsbara batterier får inte laddas upp.
• Ta ut eventuella laddningsbara batterier ur leksaken innan de laddas upp.
• Uppladdningsbara batterier får bara laddas under överinseende av en vuxen.
• Blanda aldrig olika typer av batterier, alkaliska med vanliga (kol-zink) eller laddningsbara batterier.
• Blanda aldrig nya och gamla batterier.
• Använd bara batterier av den typ (eller motsvarande) som rekommenderas.
• Sätt i batterierna med polerna åt rätt håll (+ och -).
• Ta ut uttjänta batterier ur leksaken.
• Batteriopolerna får inte kortslutas.
• Lagg användta batterier i en batteriholk eller lämna in dem.
• Kasta inte leksaken i eld.
Batterierna inuti kan explodera eller läcka.

في بعض الحالات الاستثنائية، قد تسرب السوائل من البطاريات وتسبب في حروق كيميائية مؤذية للجلد أو متلفة المنتج نفسه. لتفادي حدوث أي تسرب في البطارية:
• يجب عدم شحن البطاريات غير القابلة للشحن.
• يجب عدم وضع البطاريات القابلة للشحن داخل المنتج إذا لم تكن مفحوة جيدا.
• يجب شحن البطاريات القابلة للشحن تحت إرف الكبار فقط.
• يجب عدم استعمال أنواع المختلفة مع بعضها البعض مثل البطاريات القلوية أو البطاريات العادية (الكربون الزنك) أو البطاريات القابلة للشحن.
• يجب عدم استخدام البطاريات الجديدة والقديمة معاً.
• ينصح باستخدام البطاريات المتجانة في النوع فقط.
• يجب إدخال البطاريات تبعاً للقطبية الصحيحة (+ و -).
• يجب إزالة البطاريات المستهلكة من المنتج فوراً.
• يجب عدم وصل الأجهزة الطرفية للبطاريات ضمن دائرة كهربائية قصيرة.
• يجب التخلص من البطارية/البطاريات المستهلكة بشكل آمن.
• يجب عدم حرق هذا المنتج للتخلص منه. قد تتفجر البطاريات الموجودة داخل المنتج أو تسرب منها السوائل الكيميائية.

在特殊情况下，电池可能会泄漏液体，这种情况将会引起化学烧伤或者毁坏你的产品。为避免电池泄漏，应注意以下几点：不得对一次性的非充电电池进行充电。对于可充电的电池，在充电之前要将其从本产品中卸下。只有在成年人监护的情况下，才能对可充电电池进行充电。不得混合使用碱性，标准（碳锌），或可充电电池。不得将新旧电池混合使用。只能使用说明书中推荐的相同的或同等型号的电池类型。电池要按照所标示的正确极性进行安装。耗尽的电池要从本产品中取下，更换新电池。电源端子不能短路。请安全处置废旧电池。不要将本产品放置在火中。其中安装的电池可能会爆炸或泄漏。

I unntakstilfeller kan batteriene lekke væsker som kan føre til kjemiske brannår eller ødelægge produktet. Slik unngår du batterilekkasje:
• Bruk ikke alkaliske, standard (karbon-sink) eller oppladbare batterier samtidig.
• Batteriene må settes inn med riktig polaritet (+ og -).
• Ta ut batteriene hvis produktet blir stående lenge ubrukt.
• Ta alltid ut flate batterier.
• Kast batteriene på en forsvarlig måte. Produktet må ikke brennes.
Batteriene kan da eksplodere eller lekke.
• Batteriopolene må aldri kortslutes.
• Bruk bare batterier av samme eller tilsvarende type som anbefalt.
• Forsøk aldri å lade ikke-oppladbare batterier.
• Ta ut oppladbare batterier fra produktet før du lader dem.
• Hvis det brukes oppladbare batterier, må en voksen være med når batteriene skal lades.

Jos paristoja tai akkuja käsittelee väövrän, niistä voi vuotaa nesteitä, jotka saattavat aiheuttaa kemiallisen palovamman tai pilata tuotteen. Noudata siksi seuraavia ohjeita:
• Älä lataa paristoja uudestaan.
• Irota ladattavat akut tuotteesta ennen lataamista.
• Jos käytät irrotettavia akkuja, muista että ne saa ladata vain aikuisen valvonnassa.
• Älä käytä sekaisin tavallisia paristoja, alkaliparistoja ja ladattavia akkuja.
• Älä käytä sekaisin eri-ikäisiä paristoja ja akkuja.
• Käytä vain suostellun tyypissä tai vastaavia paristoja ja akkuja.
• Aseta paristot ja akut kotelon merkkin (+ ja -) mukaisesti.
• Irota loppuun kuluneet paristot ja akut.
• Älä koskaan aiheuta oikoskulkua pariston tai akun napojen välille.
• Hävitä paristot ja akut asianmukaisesti.
• Älä polta tuotetta.
Sen sisällä olevat paristot tai akut saattavat räjähtää tai vuotaa.

Στις μπαταρίες μπορεί να προκληθεί διαρροή και να προκαλέσει εγκαύματα ή να καταστρέψει το προϊόν. Για να αποφύγετε τη διαρροή:
• Οι μη-επαναφορτιζόμενες μπαταρίες δεν πρέπει να φορτίζονται.
• Βγάλτε τις μπαταρίες από το παιχνίδι πριν τις φορτίσετε.
• Οι επαναφορτιζόμενες μπαταρίες πρέπει να βγαίνουν από το παιχνίδι πριν την φόρτιση.
• Οι μπαταρίες πρέπει να φορτίζονται μόνο από ενήλικες.
• Μη χρησιμοποιείτε παράλληλα αλκαλικές, συμβατικές ή επαναφορτιζόμενες (κίκλιου-καδμίου) μπαταρίες.
• Μη χρησιμοποιείτε παράλληλα παλιές και καινούριες μπαταρίες.
• Χρησιμοποιήστε μπαταρίες ίδιου ή παρόμοιου τύπου με αυτόν που συνιστούμε.
• Στιγμιουργείται ότι έχετε προβεθεθεί σωστά τους πόλους των μπαταριών (+ και -).
• Απομακρύνετε τις παλιές μπαταρίες από το προϊόν.
• Μη βρκαυκυκλώνετε τους πόλους των μπαταριών.
• Πετάτε τις παλιές μπαταρίες στους ειδικούς κάδους ανακύκλωσης.
• Μην πετάτε το προϊόν σε φωτιά.
Μπορεί να προκληθεί έκρηξη ή διαρροή από τις μπαταρίες που περιέχονται.

Bazi ender durumlarda piller kimyasal yanıklara neden olabilir veya ürünüñüze zarar verebilecek birmadde sizinti yapabilir. Pil sizintiñiarından kaçınmak için:
Şarj edilemeyen piller şarj edilmemelidir.
• Şarj edilebilir piller şarj edilmeden önce üründen çıkarılmalıdır.
• Şarj edilebilir piller sadece bir yetiştikin gözetiminde şarj edilebilir.
• Alkalin, standart (karbon-çinko) veya şarj edilebilir pilleri bir arada kullanmayın.
• Eski ve yeni pilleri birlikte kullanmayın.
• Yalnızca aynı ya da eşdeğer olarak önerilen türde piller birlikte kullanılmalıdır.
• Piller doğru kutup yönünde (+ ve -) yerleştirilmelidir.
• Bitmiş piller üründen çıkarılmalıdır.
• Bestleme terminalarınere kisa devre yaptırılmamalıdır.
• Pilleri güvenli bir şekilde atın.
• Bir ürünüñüze atmayın. İçindeki piller patlayabilir veya sizinti yapabilir.

Baterie mohou vyjimečně vytékat, což může způsobit poleptání nebo poškození výrobku. Chcete-li se vyhnout vytěčení baterií:
• Nenabíjajte baterie, ktoré nejsou dobíjecí.
• Dobíjecí baterie před nabíjením vyjměte z výrobku.
• Dobíjecí baterie nabíjajte pouze pod dohledem dospělé osoby.
• Nemíchejte alkalické, standardní (karbon-zinkové) nebo dobíjecí baterie.
• Nepoužívejte současně staré a nové baterie.
• Doporučujeme používat pouze baterie stejného nebo ekvivalentního typu.
• Při vkládání baterií dodržte správnou polaritu (+ a -).
• Vybíťte baterie z výrobku vyjměte.
• Napájací svorky nesmí být zkratované.
• Baterie (baterií) se zbavujte ekologicky.
• Výrobek nevhazujte do ohně.
Baterie v něm vložené mohou vybuchnout nebo vytéct.

Výjimečně môžu z batérií unikať tekutiny, ktoré môžu spôsobiť poleptanie alebo zničie výrobku. Ak chcete zabrániť úniku kyseliny z batérií:
• Nenabíjajte baterie, ktoré nie sú označené ako nabíjateľné.
• Nabíjateľné baterie pred nabíjaním vyberte z výrobku.
• Nabíjateľné baterie pred nabíjaním vyberte z výrobku.
• Nabíjateľné batérie treba nabíjať zásadne pod dohľadom dospelaj osoby.
• Nekombinujte alkalické, štandardné (uhlíkovozinkové) a dobíjateľné batérie.
• Nekombinujte staré a nové batérie.
• Doporučujeme používať iba batérie rovnakého alebo ekvivalentného typu.
• Batérie sa musia vložiť so správnou polaritou (+ a -).
• Vybíťte batérie z výrobku vyberte.
• Napájacie terminály nesmú byť skratované.
• Batériu (batérie) bezpečne zlikvidujte.
• Výrobok nevhazujte do ohňa.
Batérie v ňom vložené môžu explodovať alebo vytiecť.

Az elemekből rítánk folyadék szivároghat, ami kémiai égési sérülést okozhat, vagy tönkretelheti a játékot. Az elemszivárgás megelőzése érdekében:
Ne töltsé újra a nem újratölthető elemeket.
• Töltés előtt távolítsa el az újratölthető elemeket a játékból.
• Ha újratölthető elemeket használ, azok csak felnőtt felügyelete alatt tölthetők újra.
• Ne tegyen be egyszerre különböző típusú – alkáli-, hagyományos (szén-cink) és újratölthető – elemeket!
• Ne keverjen régi és új elemeket.
• Csak a javasolttal azonos vagy egyenértékű elemek használata megengedett.
• Megfelelő polaritással helyezze be az elemeket (+ és -).
• A lemerült elemeket távolítsa el a termékől.
• Ne okozzon rövidzárlatot az ellátó-csatlakozón.
• Az elemek(ek) biztonságosan helyezze el.
• Ne dobja a terméket tűzbe.
A benne található összetevők felbomhatnak vagy szivárogni kezdhete.

例外的な状況では、電池の液漏れが発生し、化学的な火傷や製品の損傷が発生する場合があります。電池の液漏れを防ぐには以下の指示に従ってください。充電でない電池に充電しないでください。充電電池は、充電時に製品から外してください。充電電池は、必ず大人の監督のもとで充電してください。アルカリ電池、標準（炭素亜鉛）電池、充電電池を混ぜて使用しないでください。古い電池と新しい電池を混ぜて使用しないでください。推奨されている同一あるいは同等の電池のみ使用してください。電池は極性を正しく合わせて使用する必要があります。消耗した電池は製品から外してください。電源のターミナルはショートさせないでください。電池は安全に廃棄してください。本製品を焼却しないでください。内部の電池が爆発したり液漏れしたりする可能性があります。

In exceptional circumstances, batteries may leak fluids that can cause a chemical burn injury or ruin your product. To avoid battery leakage:
• Non-rechargeable batteries are not to be recharged.
• Rechargeable batteries are to be removed from the product before being charged.
• Rechargeable batteries are only to be charged under adult supervision.
• Do not mix alkaline, standard (carbon-zinc), or rechargeable batteries.
• Do not mix old and new batteries.
• Only batteries of the same or equivalent type as recommended are to be used.
• Batteries are to be inserted with the correct polarity (+ and -).
• Exhusted batteries are to be removed from the product.
• The supply terminals are not to be short-circuited.
• Dispose of battery(ies) safely.
• Do not dispose of this product in a fire.
The batteries inside may explode or leak.

Lors de circonstances exceptionnelles, des substances liquides peuvent s’écouler des piles et provoquer des brûlures chimiques ou endommager le jouet. Pour éviter tout écoulement des piles:
NE PAS RECHARGER DES PILES NON RECHARGEABLES.
• Les piles rechargeables doivent être retirées du produit avant d’être rechargées.
• En cas d’utilisation de piles rechargeables, celles-ci ne doivent être chargées que par un adulte.
• Ne pas mélanger des piles alcalines, standard (carbone-zinc) ou rechargeables.
• Ne jamais mélanger des piles usées avec des piles neuves.
• N’utiliser que des piles du même type que celles recommandées ou des piles équivalentes.
• Veiller à bien insérer les piles en respectant le sens des polarités (+) et (-).
• Toujours retirer les piles usées du produit.

• Ne pas court-circuiter les bornes des piles.
• Jeter les piles usées dans un conteneur réservé à cet usage.
• Ne pas jeter le produit au feu.
Les piles incluses pourraient exploser ou couler.

En circunstancias excepcionales, las pilas pueden desprender líquido corrosivo que puede provocar quemaduras o dañar el juguete. Para evitar el derrame de líquido corrosivo:
• No intentar cargar las pilas no-recargables.
• Antes de recargar las pilas recargables, sacarlas del juguete.
• Recargar las pilas recargables siempre bajo supervisión de un adulto.
• No mezclar pilas de diferentes tipos: alcalinas, estándar (carbono-cinc) o recargables.
• Utilizar pilas del tipo recomendado en las instrucciones o equivalente.
• Colocar las pilas según la polaridad indicada (+ y -).
• Retirar las pilas del juguete si no se va a utilizar durante un largo período de tiempo.
• Evitar cortocircuitos en los polos de las pilas.
• Desectar las pilas gastadas en un contenedor especial para pilas.
• No quemar el juguete ya que las pilas de su interior podrían explotar o desprender líquido corrosivo.

Em raras situações, as pilhas podem derramar fluido que pode causar queimaduras ou danificar o produto. Para evitar o vazamento de fluido:

ADVERTÊNCIA! NÃO RECARREGAR PILHAS NÃO RECARREGÁVEIS.

Retirar as pilhas recarregáveis do produto antes de proceder ao seu carregamento;
• As pilhas recarregáveis devem ser recarregadas apenas na presença de um adulto.
• Não misture pilhas alcalinas, padrão (carbono-zinco) ou recarregáveis;
• Não misturar pilhas gastas com pilhas novas;
• Só devem ser usadas pilhas e baterias do tipo recomendado ou um similar.
• As pilhas devem ser colocadas, seguindo a indicação correta de polaridade corretã(+ e -);
• Retirar as pilhas gastas do produto;
• Não provocar curto-circuito nos terminais das pilha.
• Descartar as pilhas gastas em local adequado.
• Não eliminar as pilhas no fogo, pois podem explodir ou derramar fluido.

In casi eccezionali il pile potrebbero presentare perdite di liquido che potrebberocausare ustioni

⚠ WARNING:

- Do not leave this toy close to a source of heat or in direct sunlight.
- Do not operate this toy outdoors.
- Operate this toy in a dry area.
- Avoid sand and water. If moisture gets inside the electronic compartment, remove the batteries and allow it to dry thoroughly before using.

ADVERTENCIA:

- No deje este juguete cerca a un fuente de calor o en contacto directo con la luz del sol.
- No use este juguete al aire libre.
- Use este juguete en áreas secas.
- Evite arena y agua. Si entra humedad al compartimiento electrónico, retire las baterías y deje permita que seque por completo antes de usarlo.

ATTENTION :

- NE LAISSEZ PAS CE JOUET PRÈS D'UNE SOURCE DE CHALEUR OU EXPOSÉ DIRECTEMENT À LA LUMIÈRE DU SOLEIL.
- NE PAS UTILISER CE JOUET À L'EXTÉRIEUR.
- UTILISEZ LE JOUET DANS UN ENDROIT SEC.
- ÉVITEZ LE SABLE ET L'EAU. SI L'HUMIDITÉ S'INFILTRE À L'INTÉRIEUR DU COMPARTIMENT ÉLECTRONIQUE, RETIREZ LES PILES ET LAISSEZ-LE SÉCHER COMPLÈTEMENT AVANT D'UTILISER LE JOUET.

ATENÇÃO:

- NÃO DEIXE ESTE BRINQUEDO PRÓXIMO A FONTES DE CALOR OU DIRETAMENTE EXPOSTO AO SOL.
- NÃO UTILIZE ESTE BRINQUEDO EM ÁREAS ABERTAS.
- UTILIZE ESTE BRINQUEDO EM ÁREAS SECAS.
- EVITE AREIA E ÁGUA. SE ENTRAR UMIDADE NO COMPARTIMENTO ELETRÔNICO, REMOVA AS PILHAS E DEIXE O SECAR TOTALMENTE ANTES DE UTILIZAR NOVAMENTE.

AVVERTENZA:

- Non lasciare il giocattolo vicino a una fonte di calore o alla luce diretta del sole.
- Non utilizzare all'esterno.
- Utilizzare il giocattolo su superfici asciutte.
- Evitare il contatto con sabbia e acqua. Se penetra umidità all'interno della parte elettronica, rimuovere le batterie e aspettare che i componenti elettronici siano completamente asciutti prima dell'uso.

This device complies with Part 15 of the FCC Rules.

Operation is subject to the following two conditions:

- (1) This device may not cause harmful interference, and
 - (2) this device must accept any interference received, including interference that may cause undesired operation.
- This equipment has been tested and found to comply with the limits for a Class B digital device, pursuant to part 15 of the FCC rules. These limits are designed to provide reasonable protection against harmful interference in a residential installation. This equipment generates, uses and can radiate radio frequency energy and, if not installed and used in accordance with the instructions, may cause harmful interference to radio communications. However, there is no guarantee that interference will not occur in a particular installation. If this equipment does cause harmful interference to radio or television reception, which can be determined by turning the equipment off and on, the user is encouraged to try to correct the interference by one or more of the following measures:
 - Reorient or relocate the receiving antenna.
 - Increase the separation between the equipment and receiver.
 - Connect the equipment into an outlet on a circuit different from that to which the receiver is connected.
 - Consult the dealer or an experienced radio/TV technician for help.

WARNING:

- Das nicht in die Nähe einer Wärmequelle oder in die Sonne stellen.
- Spielzeug nicht in Außenbereichen verwenden.
- Spielzeug in trockener Umgebung nutzen.
- Sand und Wasser vermeiden. Falls Feuchtigkeit in das Elektronikfach gelangt, Batterien entfernen und das Elektronikfach vor der erneuten Nutzung vollständig trocknen lassen.

OSTRZEŽENIE:

- Nie należy zostawiać zabawki blisko źródła ciepła lub na słońcu.
- Nie używać zabawki na dworze.
- Zabawkę należy używać w miejscu suchym.
- Należy unikać piasku i wody. Jeżeli wilgoć dostanie się do środka mechanizmu elektronicznego, należy usunąć baterie i pozostawić do całkowitego wyschnięcia przed kolejnym użyciem.

WAARSCHUWING

- Zet dit speelgoed niet in de buurt van een warmtebron of in het volle zonlicht.
- Gebruik het speelgoed alleen binnen.
- Gebruik dit speelgoed in een droge ruimte.
- Vermijd zand en water. Als er vocht in het batterijvak komt, verwijder dan de batterijen en laat het vak goed drogen voordat u het speelgoed opnieuw gebruikt.

ВНИМАНИЕ!

- Не оставляйте данную игрушку вблизи источника высокой температуры или под воздействием прямых солнечных лучей.
- Не используйте данную игрушку на улице.
- Используйте данную игрушку в сухом помещении.
- Избегайте попадания песка и воды. При попадании влаги в отсек для электроники выньте батарейки и хорошо просушите перед следующим использованием.

ADVARSEL:

- Efterlad ikke dette legetøj tæt på en varmekilde eller i direkte sollys.
- Brug ikke dette legetøj udendørs.
- Anvend dette legetøj i et tørt område.
- Undgå sand og vand. Hvis der kommer fugt i den elektroniske del, skal batterierne fjernes, og lejetøjet skal tørre helt, før det anvendes igen.

WARNING:

- Lämna inte denna leksak nära en värmekälla eller i direkt solljus.
- Använd inte denna leksak utomhus.
- Använd denna leksak i ett torrt utrymme.
- Undvik sand och vatten. Om fukt kommer in i elektronikutrymmet, ta ur batterierna och låt torka ordentligt innan du använder den.

ADVARSEL:

- Dette leketøyet må ikke ligge nær en varmekilde eller i direkte sollys.
- Ikke bruk dette leketøyet utendørs.
- Dette leketøyet skal brukes på et tørt sted.
- Unngå sand og vann. Hvis det kommer fukt inni elektronikken, må du ta ut batteriene og la det tørke godt før den brukes igjen.

VAROITUS:

- Älä jätä tätä lelua lämpölähteiden läheisyyteen tai suoraan auringonpaist-eeseen.
- Älä käytä tätä lelua ulkona.
- Käytä tätä lelua vain kuivissa olosuhteissa.
- Älä altista lelua hiekalle ja vedelle. Jos kosteutta pääsee leluun elektroniik-kaosastoon, irrota paristot ja anna leluun kuivua täysin ennen sen käyttöä.

ΠΡΟΕΙΔΟΠΟΙΗΣΗ:

- Μην αφήνετε το παιχνίδι κοντά σε πηγές θερμότητας ή εκτεθειμένο στο άμεσο ηλιακό φως.
- Μην χρησιμοποιείτε το παιχνίδι σε εξωτερικούς χώρους.
- Να χρησιμοποιείτε το παιχνίδι σε πρσιοςές χωρίς υγρασία.
- Να αποφεύγετε τη χρήση στην άμμο και το νερό. Αν εισχωρήσει υγρασία στη θήκη των ηλεκτρονικών εξαρτημάτων, αφαιρέστε τις μπαταρίες και αφήστε τις να στεγνώσουν εντελώς πριν τις χρησιμοποιήσετε.

NOTE: Changes or modifications not expressly approved by the manufacturer responsible for compliance could void the user's authority to operate the equipment.

Cet appareil est conforme à l'article 15 de la réglementation de la FCC. L'utilisation de ce dispositif est autorisée seulement aux deux conditions suivantes :

- (1) il ne doit pas produire de brouillage nuisible, et
- (2) l'utilisateur du dispositif doit être prêt à accepter tout brouillage radioélectrique reçu, même si ce brouillage est susceptible de compromettre le fonctionnement du dispositif.

- Cet appareil a été testé et jugé conforme aux limites de la classe B pour un appareil numérique en vertu de l'article 15 de la réglementation de la FCC. Ces limites ont été instaurées pour fournir une protection raisonnable contre toute interférence nuisible dans une installation résidentielle. Cet appareil génère, utilise et peut émettre de l'énergie radiofréquence. S'il n'est pas installé et utilisé conformément aux instructions, il peut provoquer des interférences sur les communications radio. Cependant, il n'est pas garanti que des interférences ne se produiront pas dans certaines installations. Si cet appareil cause des interférences à la réception radio ou télévisée (ce qui peut être vérifié

UYARI:

- Oyuncakçı ısı kaynağının yakınına veya doğrudan güneş ışığına yakın bir noktada bırakmayın.
- Bu oyuncakçı açık alanlarda çalıştırmayın.
- Bu oyuncakçı kuru bir alanda çalıştırın.
- Kum ve su ile temasından kaçının. Elektronik bölümün içine nem gireerse pilleri çıkarın ve kullanmadan önce tamamen kuruması için bekleyin.

UPOZORNĚNÍ:

- Nenečhávajte hračku deľší dobu poblíž zdroje tepla či na priámom slnečnom svetle.
- Hračka není určena pro venkovní použití.
- Používejte hračku v suchém prostředí.
- Zamezte kontaktu s pískem a vodou. Pokud dojde k vniknutí vlhkosti do elektronické příhradky, vyjměte baterie a před dalším použitím ji nechte důkladně vyschnout.

UPOZORNENIE:

- Nenečhávajte hračku v blízkosti tepelného zdroja alebo na priamom slnku.
- Nepoužívajte hračku vonku.
- Hračku používajte len na suchých miestach.
- Vyhybajte sa písku a vode. Ak sa do elektronickeho priečinka dostane vlhkosť, vyberte batérie a pred ďalším použitím ho nechajte dôkladne vyschnúť.

FIGYELMEZTETÉS:

- A termékét ne hagyja hőforrás közelében vagy közvetlen napfénynek kitéve.
- Kültéren ne használja a termékét.
- A termékét száraz területen használja.
- Ne használja homok és víz közelében. Ha az elektronicus rekeszbe folyadék kerül, távolítsa el az elemeket, és az ismételt használat előtt várja meg, amíg teljesen megszárad.

警告:

- おもちゃを熱源の近くに置いたり直射日光にさらしたりしないでください。
- おもちゃを屋外で使用しないでください。
- おもちゃを乾燥した場所で使用しないでください。
- 砂や水を避けてください。湿気が電子部分の内側に入った場合は、電池を外して使用前に完全に乾燥させるようにしてください。

- لا تترك هذه اللعبة بالقرب من مصدر للحرارة أو أشعة الشمس المباشرة.
- لا تترك بتشغيل هذه اللعبة في الهواء الطلق.
- قم بتشغيل هذه اللعبة في منطقة جافة.
- تجنب الرمال و الماء. إذا تسربت الرطوبة داخل المقصورة الإلكترونية، أزل البطاريات و اتركها لتجف تمامًا قبل الاستخدام.

安全警告:

- 本玩具应远离热源，防止阳光直接照射。
- 不要在户外操作这个玩具。
- 在干燥的地方操作这个玩具。
- 避免接触沙子和水。如果水分进到电子元件仓内，取出电池晾干，再使用之前应使其完全干燥。

en éteignant l'appareil puis en le remettant sous tension), l'utilisateur peut tenter de les résoudre en suivant une ou plusieurs des mesures ci-après :

- Réorienter ou déplacer l'antenne réceptrice.
- Augmenter l'espace entre l'appareil et le récepteur.
- Brancher l'appareil sur une prise de courant différente de celle sur laquelle le récepteur est branché.
- Pour obtenir de l'aide, contacter le vendeur ou un technicien radio/télévision expérimenté.

REMARQUE : Tout changement ou modification de cet appareil n'ayant pas été expressément approuvé par les parties responsables de sa conformité peut entraîner l'annulation du droit d'exploitation de l'équipement par l'utilisateur.

CAN ICES-3 (B)/NMB-3 (B)

*** Problem**
Lights do not turn on.

Possible causes
Dead batteries.
Incorrect battery placement.
Dirty battery contacts.

Try these solutions
Replace batteries.
Remove batteries and install according to instructions and diagram.
Clean battery terminals.

*** Problème**
Les lumières ne s’allument pas.

Causes possibles
Les piles sont usées.
Les piles sont incorrectement installées.
Les contacts des piles sont sales.

Essayez ces solutions
Remplacez les piles.
Retirez les piles et installez-les en respectant les directives et le schéma.
Nettoyez les bornes des piles.

*** Problema**
La luces no encienden.

Causas posibles
Pilas gastadas.
Colocación incorrecta de las pilas.
Los contactos de las pilas están sucios.

Probar estas soluciones
Cambiar las pilas del juguete.
Sacar las pilas del juguete y volverlas a poner siguiendo las instrucciones y el esquema.
Limpiar los contactos de las pilas.

*** Problema**
As luzes não acender.

Causas possíveis
Pilhas gastas.
Pilhas colocadas incorretamente.
Contactos das pilhas sujos.

Experimentar estas soluções
Substitua as pilhas.
Retirar as pilhas e voltar a instalá-las de acordo com as instruções e o diagrama.
Limpar os terminais das pilhas..

*** Problemi**
Le luci non si accendono.

Possibili cause
Le batterie sono scariche.
Inserimento errato delle batterie.
Contatti delle batterie sporchi.

Possibili soluzioni
Sostituire le batterie.
Rimuovere le batterie e re-inserirle secondo le istruzioni e il diagramma.
Pulire i terminali delle batterie

*** Problem**
Die Lichter schalten nicht ein.

Mögliche Ursachen
Batterien leer.
Batterien wurden inkorrekt eingesetzt.
Verschmutzte Batteriekontakte.

Diese Maßnahmen versuchen
Batterien austauschen.
Batterien entnehmen und gemäß Anweisungen und Abbildung einsetzen.
Batterieklemmen reinigen.

*** Problem**
Światła nie świecą.

Możliwe przyczyny
Wyczerpane baterie.
Złe włożone baterie.
Brudne styki baterii.

Wypróbować poniższe rozwiązania
Wymienić baterie.
Wyjąć baterie, a następnie włożyć je z powrotem zgodnie z instrukcją i diagramem.
Wyczyścić styki.
Przełączyć wyłącznik ON/OFF w pozycję ON.

*** Problemen**
Lichtjes werken niet.

Mogelijke oorzaken
Leg de batterijen
Batterijen onjuist geplaatst
Vervuilde batterijcontactpunten

Probeer deze oplossingen
Vervang batterijen
Verwijder de batterijen en plaats ze opnieuw volgens de instructies en de afbeelding
Maak de contactpunten schoon.

*** Проблема**
Лампочки не горят.

Возможные причины
Разряженные батарейки.
Неправильно установленные батарейки.
Грязные контакты батареек

Возможное решение проблемы
Замените батарейки.
Вывньте батарейки и вставьте в соответствии с инструкцией и рисунком.
Почистите контакты батареек.

*** Problem**
Lysene tænder ikke.

Mulige årsager
Flade batterier.
Forkert placering af batterier.
Beskidte batterikontakter.
Flade batterier.
Forkert placering af batterier.
Beskidte batterikontakter.

Prøv disse løsninger,
Udskift batterierne.
Fjern batterierne, og isæt dem i henhold til vejledningen og diagrammet.
Rens batteriklemmerne.Udskift batterierne.
Fjern batterierne, og isæt dem i henhold til vejledningen og diagrammet.
Rens batteriklemmerne.

*** Problem**
Ljuset tänds inte.

Möjliga orsaker
Förbrukade batterier.
Felaktigt batteriplacering.
Smutsiga batterikontakter.

Prova dessa lösningar
Byt batterier.
Ta ut batterierna och installera enligt instruktioner och diagram.
Rengör batteripolerna.

*** Problem**
Lys slår seg ikke på.

Mulige årsaker
Tomme batterier.
Batteriplasseringen er feil.
Batterikontaktene er tilsmusset.

Prøv disse løsningene
Skift batterier.
Skift batterier og installer batteriene i henhold til instruksjonene og diagrammet.
Rengjør batteriklemmene.

*** Ongelma**
Valot eivät syty päälle.

Mahdolliset syyt
Paristoissa ei ole virtaa.
Paristo on asetettu väärin paikalleen.
Paristokontaktit likaiset.

Kokeile seuraavia ratkaisuja:
Vaihda paristot.
Vaihda paristot ja asenna uudet ohjeiden ja kuvien mukaisesti.
Puhdista paristonavat.

*** Πρόβλημα**
Οι φωτεινές λυχνίες δεν ανάβουν.

Πιθανές αιτίες
Οι μπαταρίες έχουν αδειάσει.
Η τοποθέτηση των μπαταριών είναι λανθασμένη.
Οι επαφές της μπαταρίας είναι βρώμικες.

Δοκιμάστε αυτές τις λύσεις
Αντικαταστήστε τις μπαταρίες.
Αφαιρέστε τις μπαταρίες και τοποθετήστε τις σύμφωνα με τις οδηγίες και το διάγραμμα.
Καθαρίστε τους ακροδέκτες των μπαταριών

*** Sorun**
Işıklar yanmıyor.

Olası nedenler
Pillerin bitmesi.
Pillerin yanlış yerle _tirilmesi.
Kirli pil kontakları.

Bu çözümleri deneyin
Pilleri de _irin.
Pilleri çıkarın ve talimatlar ile _emalara göre tekrar takın.
Pil kutuplarını temizleyin.

*** Problémy**
Světla se nerozsvítí.

Možné příčiny *(jsou-li platné)
Vybité baterie.
Nesprávné vložené baterie. Kontakty baterií jsou znečištěné.

Vyzkoušejte tato řešení
Vyměňte baterie.
Vyměňte baterie a vložte je podle pokynů a nákrasu. Očistěte kontakty baterií.

*** Problémy**
Svetlá sa nerozsvietia.

Možné príčiny * (ak je to relevantné)
Prázdne batérie.
Nesprávne umiestnenie batérie. Znečistené kontakty batérií.

Vyskúšajte tieto riešenia
Vymeňte batérie.
Vyberte batérie a vložte ich v súlade s pokynmi a nákrasom. Očistite terminály batérií.

*** Problémák**
A fények nem világítanak.

Lehetséges okok *(adott esetben)
Az elemek lemerültek.
Az elemek nem megfelelően vannak behelyezve. Az elemek érintkezői elszenny-eződtek.

Próbálja ki az alábbi megoldásokat
Cserélje ki az elemeket.
Távolítsa el az elemeket, majd helyezze be őket az utasításoknak és az ábrának megfelelően. Tisztítsa meg az elemek érintkezőit.

*** 問題**
ライトが光らない。

可能性のある原因
電池が切れている。
電池が正しく取り付けられていない。
電池の接点が汚れている。

これらの対策をお試しください
電池を交換してください。
電池を外して、指示および図に従って取り付けてください。
電池のターミナルを掃除してください。

المشكلة
المصابيح لا تضيء .

الأسباب الممكنة
البطاريات فارغة.
وضع غير صحيح البطارية.
أطراف البطارية متسخة.

قم بتجربة هذه الحلول
استبدل البطاريات.
أزل البطاريات وثبتها وفقاً للإرشادات والرسم.
قم بتنظيف أطراف البطارية.

*** 问题**
指示灯打不开。

可能的原因
废旧电池。
电池安装不正确。
电池触点油污或受损。

尝试这些解决方案
更换电池。
根据说明书和安装图拆卸和安装电池。
清洁电池接线端子。

Batteries included with this toy are for demonstration purposes only. In order to get the best performance from this toy, we recommend that fresh alkaline batteries be inserted prior to use. Les piles incluses dans ce jouet sont uniquement destinées à l'essai du jouet. Il est recommandé de remplacer les piles incluses par des piles alcalines neuves afin d'obtenir une performance optimale du jouet.

Las pilas que incorpora el juguete son solo a efectos de demostración. Para un mejor funcionamiento, recomendamos sustituirlas por pilas alcalinas nuevas al adquirir el juguete.

As pilhas incluídas com este brinquedo destinam-se apenas a efeitos de demonstração. Para obter o melhor desempenho deste brinquedo, recomendamos que, antes da utilização, sejam instaladas pilhas novas alcalinas.

Le pile fornite con il giocattolo servono solo per la dimostrazione. Per un funzionamento ottimale del giocattolo,

inserire delle pile alcaline nuove prima dell'uso. Die enthaltenen Batterien dienen ausschließlich Vorführzwecken im Geschäft. Ihre Lebensdauer kann daher beeinträchtigt sein. Für optimale Leistung dieses Produkts empfehlen wir, die beigefügten Batterien vor dem Gebrauch des Produkts durch neue Alkali-Batterien zu ersetzen. Batterie dołączone do tej zabawki służą wyłącznie do celów demonstracyjnych. W celu zapewnienia jak najlepszego działania zabawki przed użyciem zalecamy wymianę baterii na nowe baterie alkaliczne.

De bijgeleverde batterijen zijn alleen bedoeld om te laten zien hoe het speelgoed werkt. Voor de beste prestatie van het speelgoed, raden wij aan om nieuwe alkalinebatterij te plaatsen voor het gebruik.

Батарейки, входящие в комплект с этой игрушкой, предназначены только для демонстрационных целей. Для оптимальной работы игрушки рекомендуем вставить две новые щелочные батарейки.

Batterierne, der følger med dette legetøj, er kun

til demonstration. For at få den bedste ydelse fra dette legetøj, anbefaler vi, at nye alkaliske batterier sættes for brug.

Batterierna som medföljer leksaken är endast för demonstrationssyfte. För att få bästa prestanda från den här leksaken, rekommenderar vi att nya alkaliska batterier sätts i före användning. Batteriene som fulgte med dette leketøyet er kun beregnet for demonstrasjon. For at leketøyet skal yte best mulig, anbefaler vi å sette i nye alkaliske batterier for bruk.

Tämän lelun mukana toimitetut paristot ovat tarkoitettu vain esittelykäyttöön. Saavuttaaksesi tämän lelun parhaan suorituskyvyn, suosittelemme, että asennat uudet alkaliparistot ennen lelun käyttöä.

Οι μπαταρίες που περιλαμβάνονται είναι μόνο για τη δοκιμή του προϊόντος. Για καλύτερα αποτελέσματα, προτείνουμε να αντικαταστήσετε τις μπαταρίες με καινούριες πριν από την χρήση. Bu oyuncuğun içindeki piller yalnızca tanıtım amaçlıdır. En iyi performans için kullanımdan önce oyuncuğa yeni alkalil piller takılmasın öneririz.

Baterie dodávané s touto hračkou jsou určeny pouze pro předváděcí účely. Aby hračka fungovala co nejlépe, doporučujeme před použitím vložit nové alkalické baterie. Batérie dodávané s touto hračkou slúžia len na ukážku. Ak chcete dosiahnuť čo najlepší výkon hračky, odporúčame pred začiatkom používania vložiť nové alkalické batérie. A legjobb teljesítmény elérése érdekében azt javasoljuk, hogy a használat előtt helyezzen be új alkáli elemeket.

このおもちゃに同梱されている電池は、デモのみを目的としています。おもちゃの最高の性能を發揮するには、使用前に新しいアルカリ電池を挿入されることを推奨いたします。

البطاريات المتضمنة مع هذه اللعبة هي لأغراض التجربة فقط. لأفضل أداء لهذه اللعبة، ننصح بإدخال بطاريات قوية جديدة قبل الاستخدام.

本玩具配套的电池仅用于演示目的。为了在操作本玩具时获得其最佳的性能，我们建议在使用本玩具之前安装新的碱性电池。

BATTERY SAFETY INFORMATION / MISES EN GARDE AU SUJET DES PILES / INFORMACIÓN DE SEGURIDAD ACERCA DE LAS PILAS / INFORMAÇÕES DE SEGURANÇA SOBRE PILHAS / NORME DI SICUREZZA PER LE PILE / BATTERIESICHERHEITSHINWEISE / INFORMACJE DOTYCZĄCE BEZPIECZNEGO KORZYSTANIA Z BATERII / BATTERIJ-INFORMATIE / ИНФОРМАЦИЯ ПО БЕЗОПАСНОМУ ОБРАЩЕНИЮ С БАТАРЕЙКАМИ / INFORMATION OM SIKKER BRUG AF BATTERIER / BATTERIINFORMATION / SIKKERHETSINFORMASJON OM BATTERIENE / YLEISIÄ OHJEITA PARISTOJEN JA AKKUJEN TURVALLISESTA KÄYTTÖSTÄ / ΠΑΡΟΧΟΡΕΙΣ ΓΙΑ ΤΙΣ ΜΠΑΤΑΡΙΕΣ / PIL GÜVENLİĞİ BİLGİLERİ / BEZPEČNOSTNÍ INFORMACE O BATERIÍCH / BEZPEČNOSTNÉ INFORMÁCIE O BATERIÁCH / A BIZTONSÁGOS ELEMHASZNÁLATRA VONATKOZÓ TUDNIVALÓK / 電池についてのご注意 / معلومات عن البطاريات والسلامة

⚠ WARNING: Batteries are to be changed or installed by an adult. Do not leave batteries within reach of children. ADVERTENCIA: Las pilas deben ser cargadas o colocadas por un adulto. No dejar las pilas al alcance de los niños.

ATTENTION : LES PILES DOIVENT ÊTRE REMPLACÉES OU INSTALLÉES PAR UN ADULTE. NE PAS LAISSER LES PILES À LA PORTÉE DES ENFANTS.

ATENÇÃO: AS PILHAS DEVEM SER

保留备用

产品中有害物质的名称及含量						
部件名称	有害物质或元素					
	铅 (Pb)	汞 (Hg)	镉 (Cd)	六价铬 (Cr(VI))	多溴联苯 (PBB)	多溴二苯醚 (PBDE)
电路板组件	×	○	○	○	○	○

本表格依据 SJ/T 11364 的规定编制。
○：表示该有害物质在该部件所有均质材料中的含量均在 GB/T 26572 规定的限量要求以下
×：表示该有害物质至少在该部件的某一均质材料中的含量超出 GB/T 26572 规定的限量要求。
备注：以上标示“×”的部件，部分含有有害物质超过限量要求是由于目前科学及技术有限，暂时无法实现替代或减量化。



本产品的环保使用期限为 10 年。产品使用期限是指用户按照说明书描述正常使用条件下有效。

《废弃电器电子产品回收处理管理条例》指示性说明
为了更好的关爱及保护地球，当用户不再需要此产品或产品寿命终止时，请遵守国家废弃电器电子产品回收处理相关法律法规，将其交给当地具有国家认可的回收处理资质厂商进行回收处理。

SUBSTITUÍDAS OU INSTALADAS POR UM ADULTO. NÃO DEIXAR AS PILHAS AO ALCANCE DAS CRIANÇAS. AVVERTENZA: Le pile devono essere sostituite o inserite da un adulto. Tenere le pile fuori dalla portata dei bambini. WARNING: Die Batterien müssen von einem Erwachsenen eingesetzt und ausgetauscht werden. Die Batterien nicht in der Reichweite von Kindern lassen. OSTRZEŻENIE: Baterie może wkładać i wymieniać tylko osoba dorosła. Baterie należy przechowywać poza zasięgiem dzieci. WAARSCHUWING: De batterijen moeten worden geïnstalleerd en vervangen door een volwassene. Houd de batterijen buiten het bereik van kinderen. ПРЕДУПРЕЖДЕНИЕ! Замена и установка батареек должна осуществляться взрослым. Не оставляйте батарейки в пределах досягаемости детей. ADVARSEL: Batterierne skal udskiftes eller installeres af en voksen. Anbring ikke batterierne inden for børns rækkevidde. WARNING: Batterier får endast installeras och bytas av en vuxen. Lämna inte batterier inom räckhåll för barn. ADVARSEL: Batteriene må skiftes eller installeres av en voksen. Oppbevar batteriene utenfor barns rekkevidde. VAROITUS: Aikuisen tulee asentaa ja vaihtaa paristot. Älä jätä paristoja lasten ulottuville. ΠΡΟΣΟΧΗ: Η τοποθέτηση ή η αντικατάσταση των μπαταριών πρέπει να γίνεται από ενήλικα. Μην αφήνετε τις μπαταρίες σε ομήλια που μπορεί το παιδί να τις φτάσει. UYARI: Piller bir yetişkin tarafından değiştirilmeli veya takılmalıdır. Pilleri çocukların erişemeyeceği yerlerde saklayın. UPOZORNENÍ: Vkládání a výměnu baterií musí provádět dospělá osoba. Nenechávejte baterie v dosahu dětí. UPOZORNENIE: Batérie musí vymieňať alebo vkladať dospelá osoba. Nenechávajte batérie v dosahu detí. FIGYELMEZTETÉS: Az elemek cseréjét és behelyezését felnőtt végezze. Az elemek gyermekkel elől elzárva tartandók. 注意：電池的交換是保護者的一方行請。お子さんの手が届くところに電池を置かないでください。 تحذير : يجب استبدال البطارية من قبل الكبار فقط. يجب عدم ترك البطاريات في متناول الأطفال.

警告：電池需由成人更換或安裝。請勿將電池放在兒童可接觸到的地方



XBOX 360



COLLECTOR BUILDING SET
BOÎTE DE CONSTRUCTION
POUR COLLECTIONNEUR

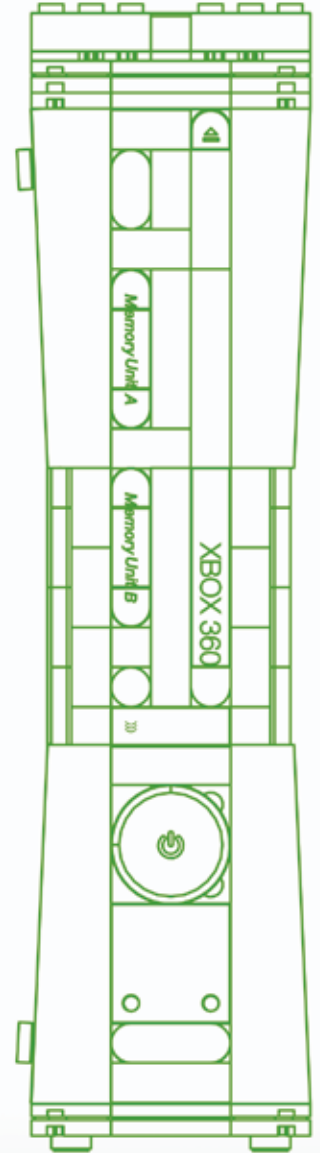
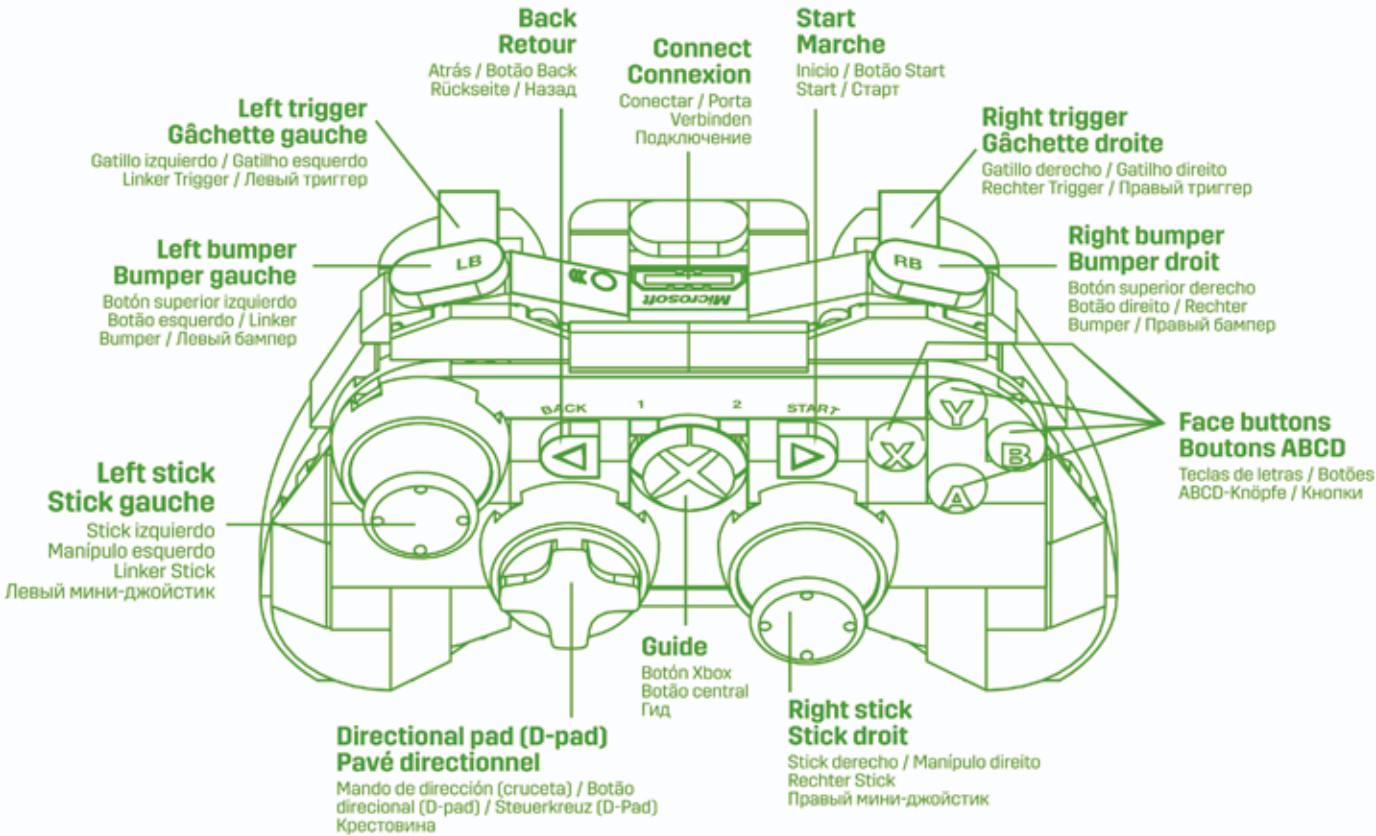

MEGASHOWCASE.com



© 2023 Microsoft Corporation. All Rights Reserved. Microsoft, Halo, the Halo logo, Xbox, the Xbox logo, and 343 Industries are trademarks of the Microsoft group of companies.

Mattel Canada Inc. Mississauga, Ontario L5R 3W2.
MADE IN CHINA. FABRIQUÉ EN CHINE. FABRICADO NA CHINA. HECHO EN CHINA.
ИЗГОТОВЛЕНО В КИТАЕ. ÇIN'DE ÜRETİLMİŞTİR. صنع في الصين.

© 2023 MEGA Brands &™ MEGA Brands.
Printed in China / Imprimé en Chine



AD-HWW15-02B