

MEGA™

HotWheels

BUILDING SETS

1



**WONDER
BUILDERS™**

GYG66

TWINDUCTION™





Fuel their imagination with building toys that support creative thinking and problem solving.

Stimulez leur imagination avec des jouets de construction qui encouragent l'esprit créatif et la résolution de problèmes.

Alimenta su imaginación con juguetes de construcción que ayudan a desarrollar el ensamblado creativo y la resolución de problemas. / Abasteça a imaginação dele com brinquedos de montar que suportam o pensamento criativo e a resolução de problemas. / Dieses Bauspielzeug beflügelt nicht nur die Phantasie, sondern unterstützt auch kreatives und lösungsorientiertes Denken. / Разжигайте воображение детей с помощью конструктора, развивающего творческие способности и логическое мышление.



Authentic details Détails authentiques

Detalles auténticos
Detalhes autênticos
Authentische Details
Реалистичные детали



Special pieces Pièces spéciales

Piezas especiales
Peças especiais
Spezielle Teile
Специальные детали



Compatible with major brands Compatible avec les grandes marques

Compatible with marcas líderes
Compatível com a maioria das marcas
Mit Bausteinen führender Marken kombinierbar
Совместимость с основными брендами

Learn more
Pour en savoir plus

Más información · Sabe mais · Weiterer
Infos gibt es auf · Узнать больше

play.megaconstrux.com

MEGA
CONSTRUX

MEGA
UNBOXED

Build Assemblez

Construye | Constrói
Bauen | Стройте



Share | Partagez

Devices not included | Appareils non inclus | Dispositivos não incluído | Dispositivos não incluídos | Geräte nicht enthalten
Устройства не входят в комплект

Build ideas & challenges! Des idées de construction et des défis!

¡Crea ideas y desafíos!
Desafios e ideias para construções!
Verschiedene Bauideen und
Herausforderungen!
Открывайте новые
идеи и испытания!



Set(s) sold separately and subject to availability. / Ensemble(s) vendu(s) séparément. Certains produits peuvent ne pas être commercialisés. / Se vende(n) por separado y está(n) sujeto(s) a disponibilidad. / Conjunto(s) vendido(s) em separado e sujeito(s) à disponibilidade. / Set in vendita separatamente, secondo disponibilità. / Das/Die Set(s) sind separat erhältlich. Набор(-ы) продаются отдельно, при наличии.

unboxed.megaconstrux.com



1





2



2x

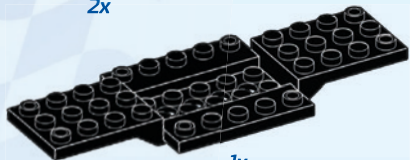

1x

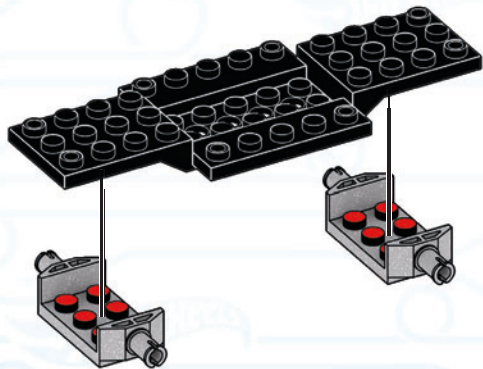

3



1x



1x

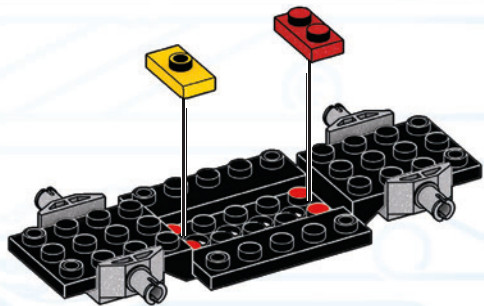

4



1x



1x

5



2x

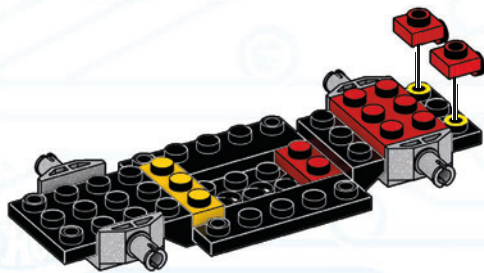
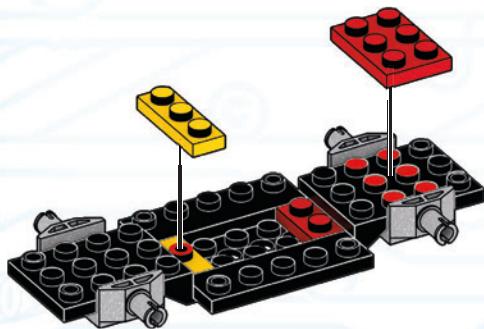



TWINDUCTION™

6



1x

7



1x



1x

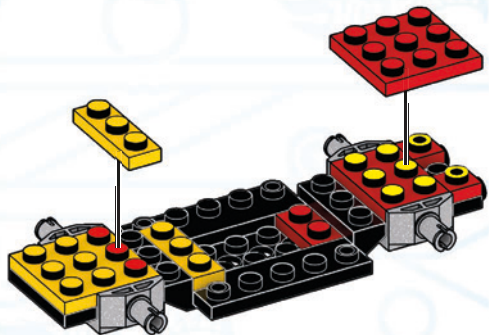
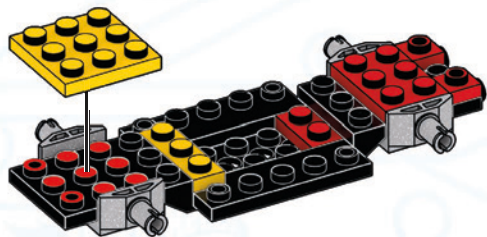

8



2x



2x

9



1x



1x

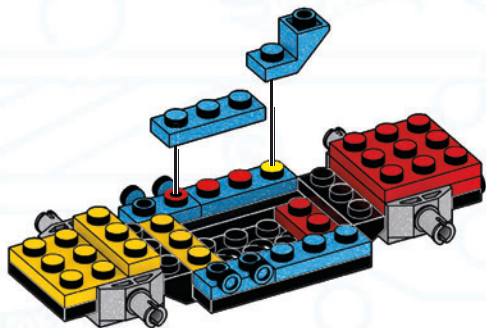
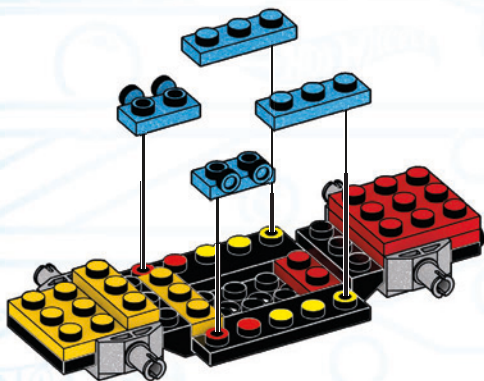



TWINDUCTION™

10



1x

11



1x

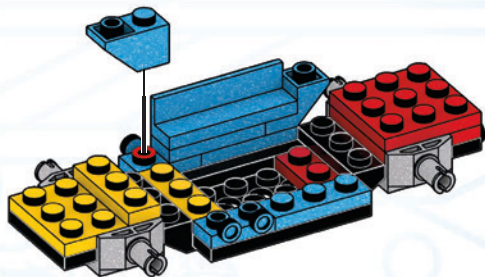
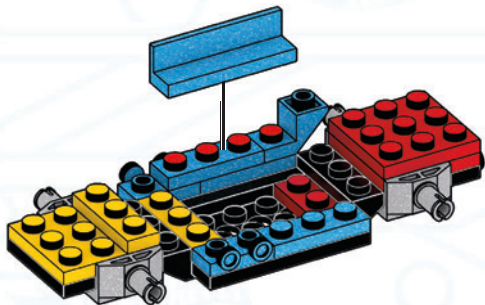

12

1x

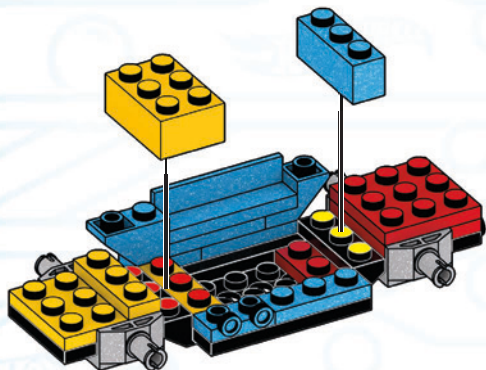

1x

**13**

1x

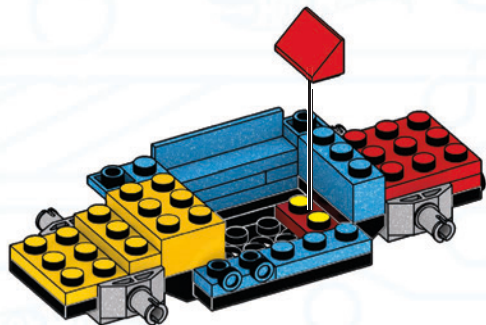



14



1x



1x

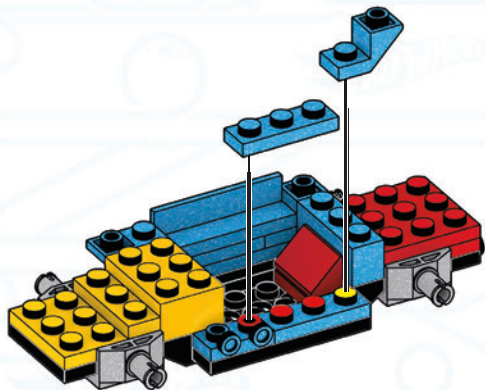

15



1x

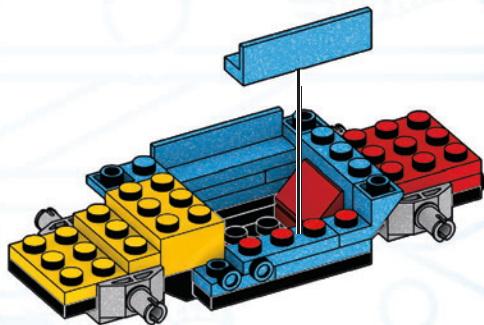

16



1x

17



2x

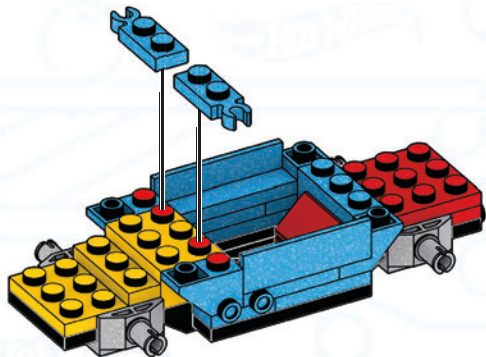
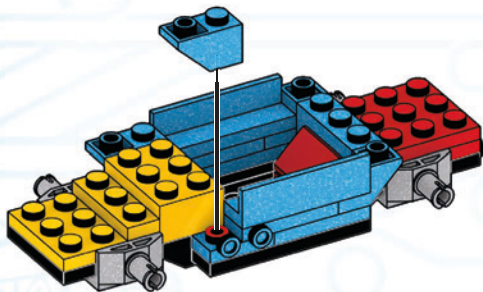



TWINDUCTION™

18



1x

19



1x



1x

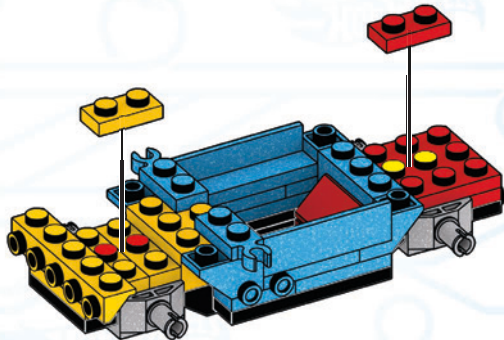
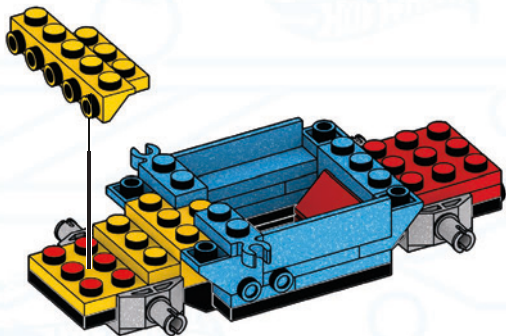

20

4x

21

1x

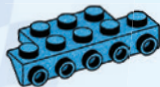

1x

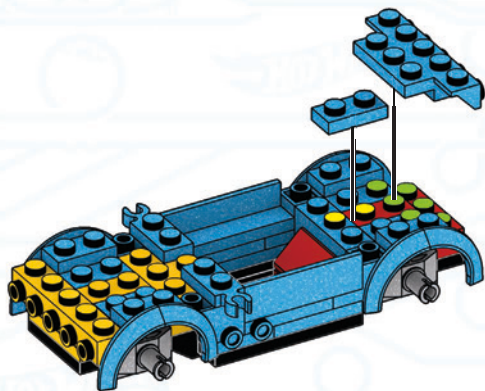
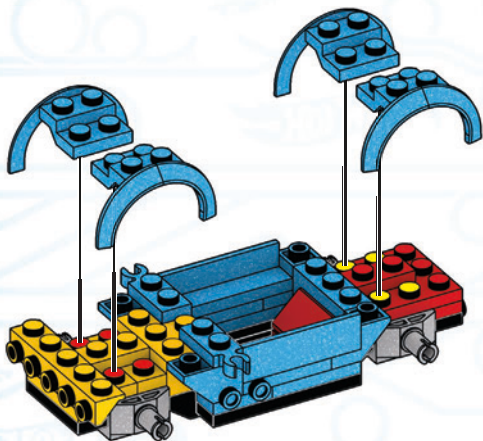



TWINDUCTION™

22



2x

23



1x



1x

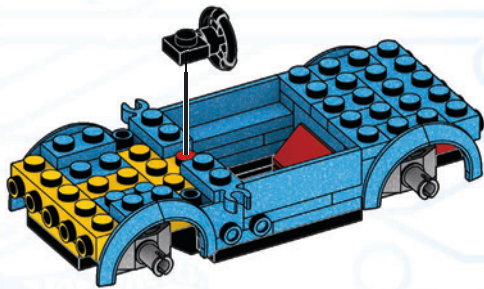
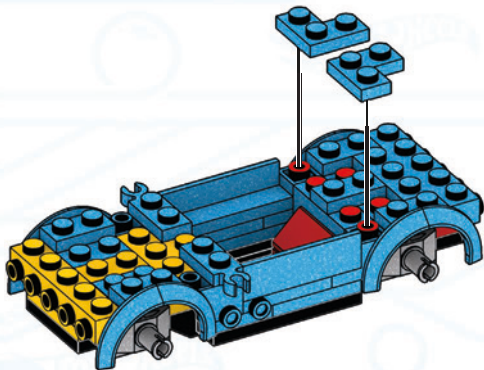

24



2x



1x

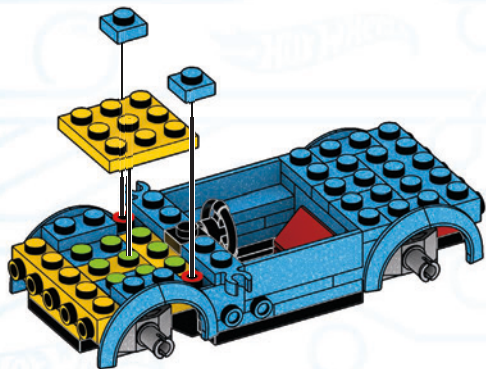

1

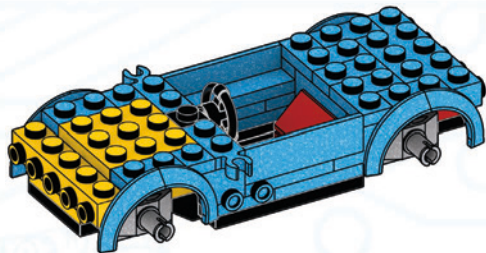

2



25



1x



1x

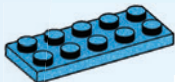

1x

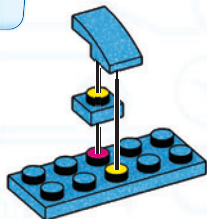

26



1x



1x

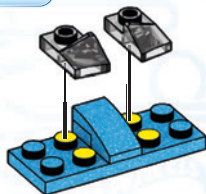

27



1x



1x

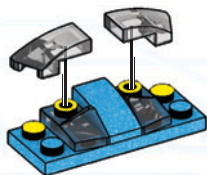

28



2x

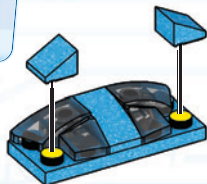

1



2

29

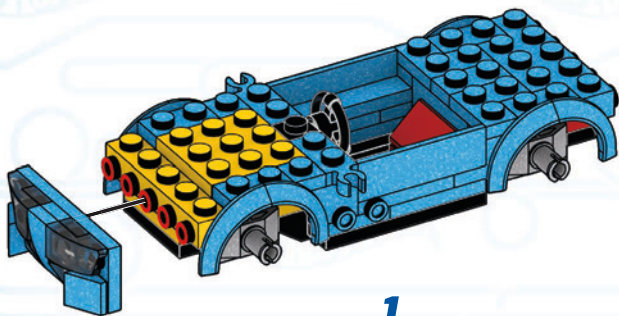

1

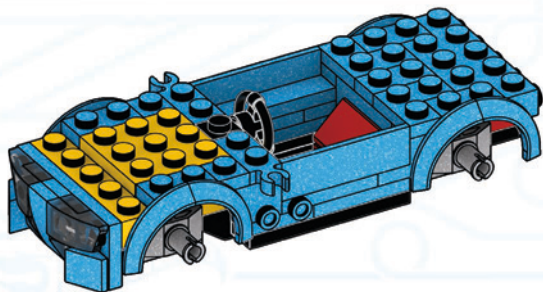

2



TWINDUCTION™

30



1x

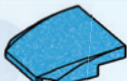

1x

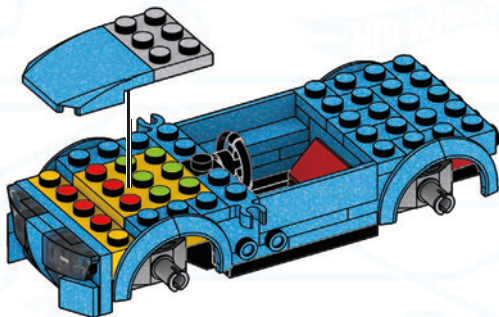

31



1x



1x

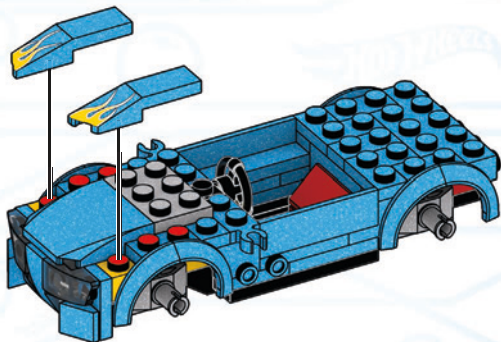

32

1x

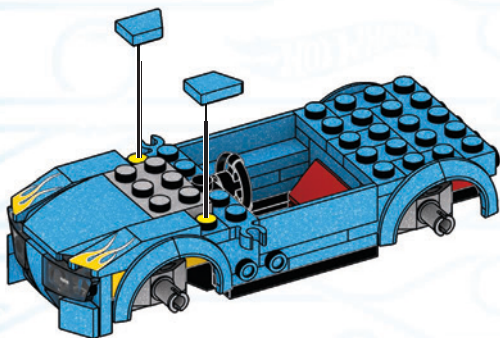

1x

**33**

1x

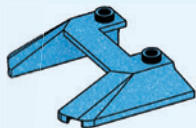

1x

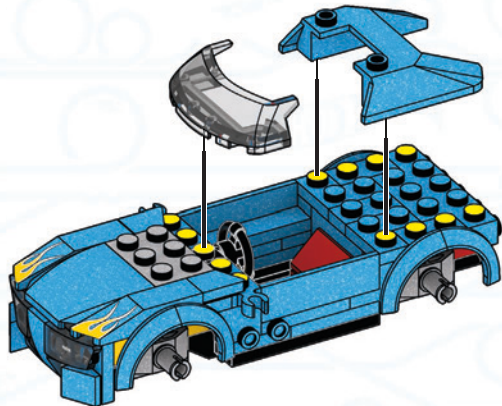



TWINDUCTION™

34



1x

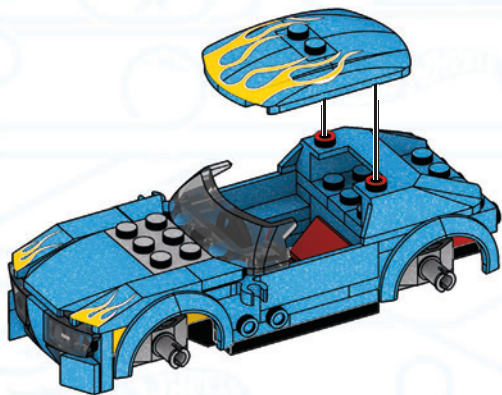

35



1x



1x



1x

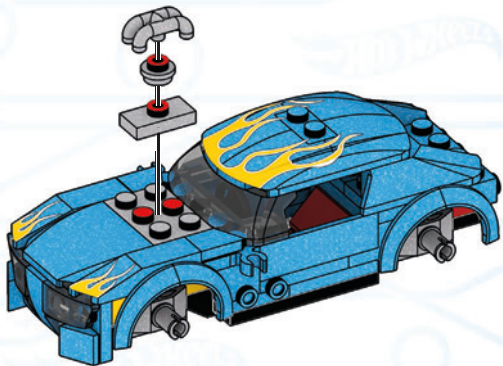

36

2x

37

2x

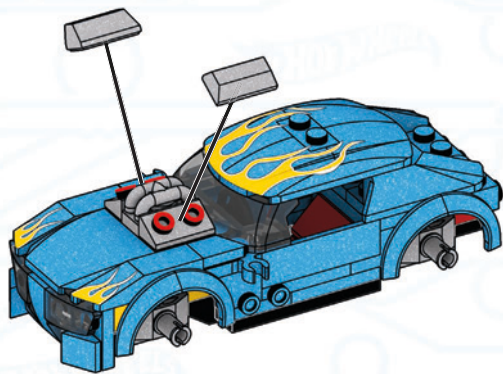
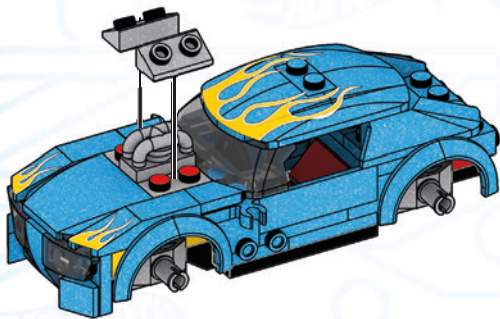



TWINDUCTION™

38



1x



1x



1x

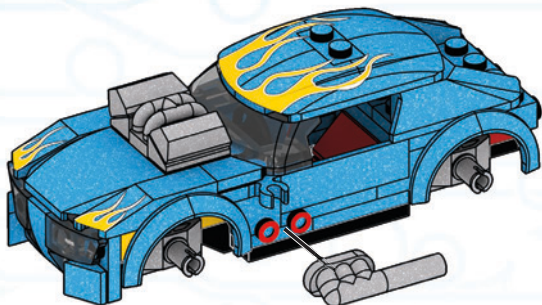
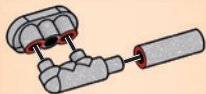

1

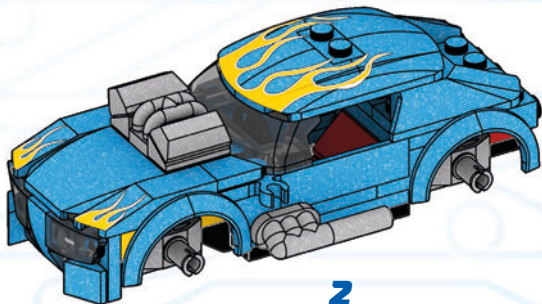

2

39



1x



1x



1x

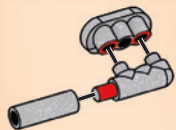
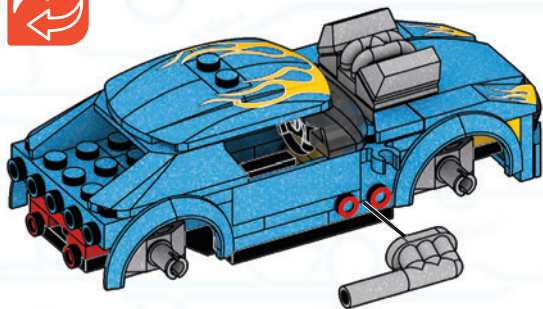

40



1x

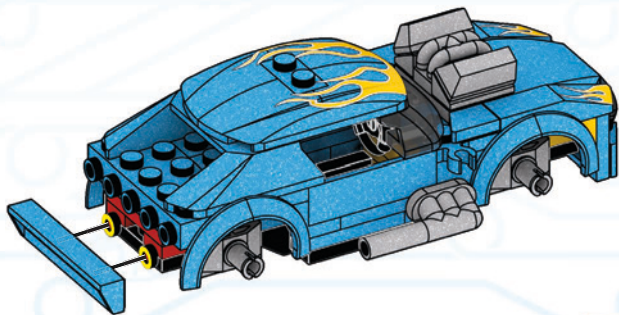



TWINDUCTION™

41



1x



2x

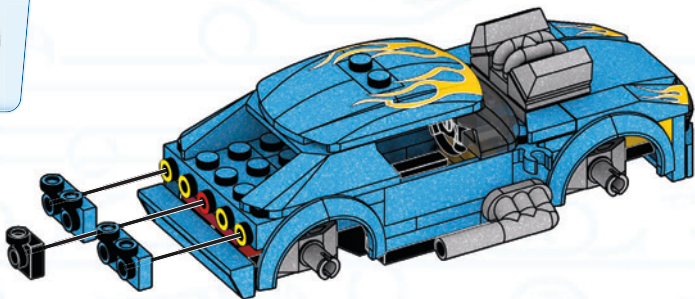

42



1x



2x

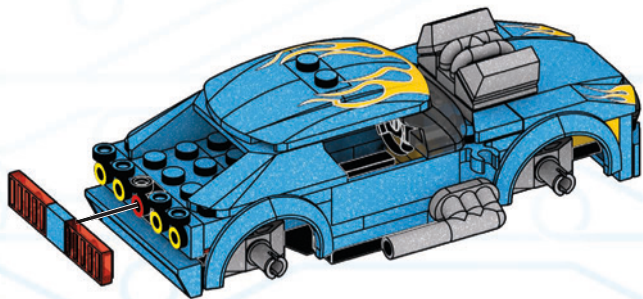

43



1x

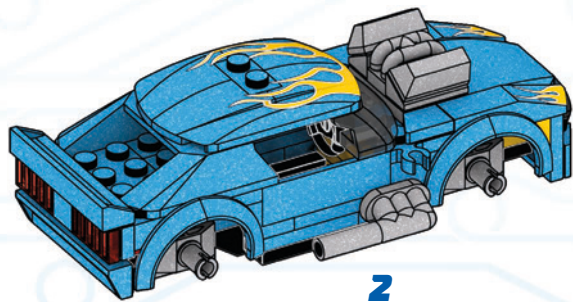
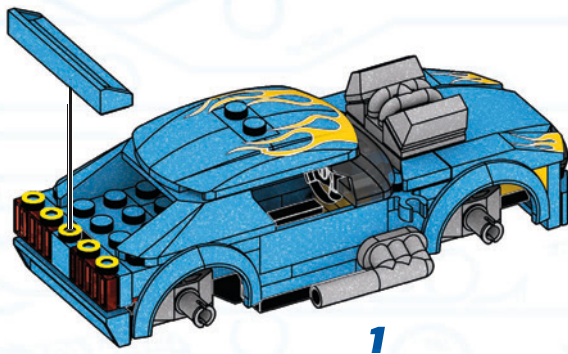



TWINDUCTION™

44



4x

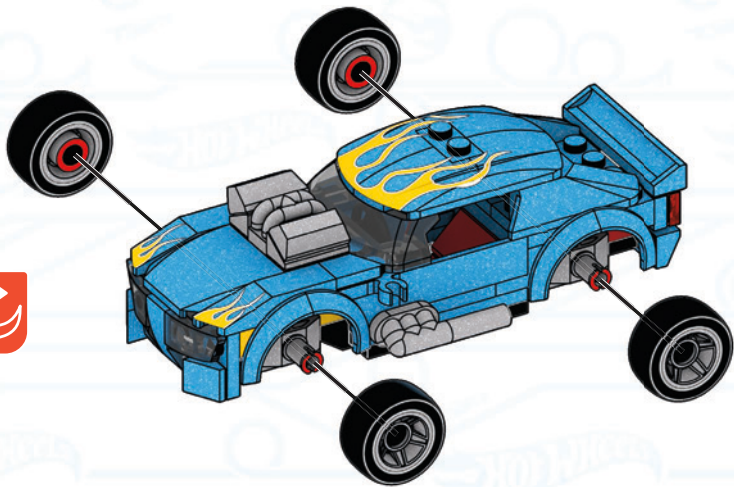

45



1x



1x

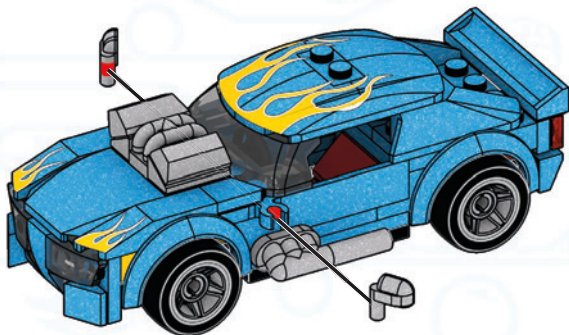

1

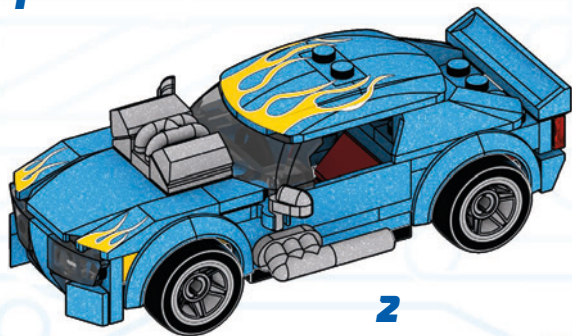

2

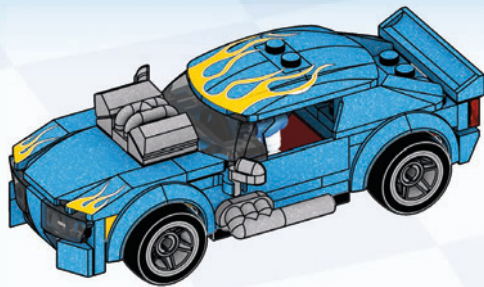
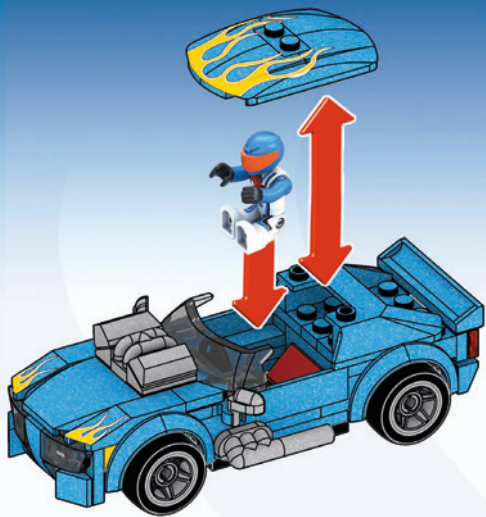

Rebuild your cars into monster trucks * Réassemble tes voitures pour en faire des Monster Trucks

Convierte tus coches en "Monster Trucks"

Transforma os seus carros em Monster Trucks

Fahrzeuge in Monster Trucks umbauen

Перестраивай свои машинки в монстр-траки



Set(s) sold separately and subject to availability. / Ensemble(s) vendu(s) séparément. Certains produits peuvent ne pas être commercialisés. / Se vende(n) por separado y está(n) sujeto(s) a disponibilidad. / Conjunto(s) vendido(s) em separado e sujeito(s) à disponibilidade. / Set in vendita separatamente, secondo disponibilità. / Das/Die Set(s) sind separat erhältlich. / Zestaw(y) sprzedawany(e) oddzielnie w zależności od dostępności. / Set(s) apart verkrijgbaar en afhankelijk van beschikbaarheid. / Набор(-ы) продаются отдельно, при наличии. / Sæt sælges separat og så længe lager haves. / Seten säljs separat så länge lagret räcker. / Settet/settene selges separat så langt lageret rekker. / Pakkaus/pakkaukset myydään erikseen, saatavuus voi vaihdella. / Το(α) σετ πωλούνται ξεχωριστά και ανάλογα με τη διαθεσιμότητα. / Setler ayrı olarak satılır ve stoklarına sinirlidir. / Set (sety) se prodává (prodávají) samostatně dle aktuální nabídky. / Šuprava/-y sa predáva (jú) samostatne a podľa dostupnosti. / A készlet(ek) külön kapható(k), az elérhetőség változhat. /

セット商品は別売りになります。在庫状況は別途ご確認をお願いします。 /
 ٲٲاع المجموعة أو المجموعات على حدة وتتخضع لتوافرها.

每套单独发售，按供货情况决定。

Additional purchase required. / Achat additionnel requis. / Zusätzlicher Kauf erforderlich. / Richiede acquisto addizionale. / Aanvullende aankoop vereist. / Requiere compra adicional. / Requier compra adicional. / Ytterligere kjøp kreves. / Edellyttää lisäosien ostamista. / Supplerende køb nødvendig. / Ekstra kjøp kreves. / Wymagany dodatkowy zakup. / Vyžaduje dodatečný nákup. / Vyžaduje sa dokúpenie. / További vásárlás szükséges. / Необходима дополнительная покупка. / Απαιτείται επιπλέον αγορά. / Ek ürün satın alınması gerekir.

تتطلب شراء القطع الإضافية.

Most models can be built one at a time. / La plupart des modèles peuvent être construits un à la fois. / La mayoría de modelos se pueden construir de uno en uno. / A maioria dos modelos pode ser construída separadamente. / La maggior parte dei modelli possono essere realizzati uno per volta. / Die meisten Modelle können eines nach dem anderen gebaut werden. / Większości modeli nie da się budować jednocześnie z innymi. / De meeste modellen kunnen één voor één gebouwd worden. / Большинство моделей могут быть собраны по одной за раз. / De fleste modeller kan bygges enkeltvis. / De flesta modeller kan bygges en i taget. / De fleste modellene kan bygges en om gangen. / seimatt mallit voidaan rakentaa yksi kerrallaan. / Τα περισσότερα μοντέλα μπορούν να κατασκευασθούν ένα ένα. / Modellerein çoğu ayrı ayrı inşa edilmeyi gerektirebilir. / Většinou lze najednou sestavit pouze jeden model. / Väčšina modelov môže byť zostavená iba raz. / A modellek többségéből egyszerre csak egy építhető.

ほとんどのモデルは、一度に一つを組み立てることができます。

يمكن تركيب التصاميم الواحد تلو الآخر.

大多數型號可一次建構。 29

1x
AM18560APG

1x
AM07223APG

3x
AM03328AYP

2x
AM77574AMC

1x
AM79590F

1x
AM80546F

2x
AM17127AYP

1x
AM74299AYP

1x
AM74300AYP

1x
AM74400APG

1x
AM74401APG

1x
AM18220F

2x
AM17506APG

2x
AM81020APG

1x
AM18559APG

2x
AM09198X

1x
AM07590APG

1x
AM07590BYE

1x
AM09393BYE

2x
AM09393AMC

1x
AM09393AYP

4x
AM79070AYP

2x
AM18272APG

2x
AM76469APG

1x
AM74427AGY

1x
AM74426AGY

1x
AM72494AGY

1x
AM72495AGY

2x
AM17522AYP

2x
AM18232APG

1x
AM78486AYP

2x
AM01417AYP

1x
AM03019AMC

2x
AM72917AYP

2x
AM15484AYP

1x
AM16384AYP

4x
AM01314AYP

2x
AM01314BYE

4x
AM80972AP

1x
AM03772APG

1x
AM03772AMC

1x
AM03772AYP

1x
AM03873BYE

1x
AM81163AMC

2x
AM81163BYE

1x
AM81252AYP

1x
AS-GYG66-09

1x
AS-GYG66-10

2x
AM17521AYP

1x
AM80970BYE

1x
AM80969AYP

2x
AM81253AYP

1x
AM80965AYP

4x
AS-GYG66-01

2x
AM80971APG

1x
AM80968AYP

1x
AM80975F

1x
FIG-GYG66-B

1x
AM80538AGY

1x
AS-GYG66-08



Missing pieces?
Pièces manquantes?
¿Partes faltantes? · Perdeu peças?
Fehlen Teile? · Не хватает деталей?
support.megabrand.com

Mattel Europa B.V., Gondel 1, 1186 MJ Amstelveen, Nederland. Mattel U.K. Limited, The Porter Building, 1 Brunel Way, Slough SL1 1FQ, UK. Mattel France, Parc de la Cerisaie, 1/3/5 allée des Fleurs, 94260 Fresnes Cedex. N° Cristal 0969 36 99 99 (Numéro non surtaxé) ou www.Jesjouetsmattel.fr Mattel Belgium, Trade Mart, Atomiumsquare, Bogota 202 – B 275, 1020 Brussels. Gratis nummer België: 0800 – 16 936 – Gratis nummer Luxemburg: 800 – 22 784 – Gratis nummer Nederland: 0800 – 262 88 35. Deutschland : Mattel GmbH, Solmsstraße 4, D-60486 Frankfurt am Main. Schweiz: Mattel AG, Kirchstrasse 24, CH-3097 Liebefeld. Österreich: Mattel Ges.m.b.H., Campus 21, Liebermannstraße A01 404, A- 2345 Brunn/Gebringe. Mattel Italy Srl, Via Bracco, 6-MAC 6, 20159 Milano, Italy. Servizio assistenza clienti: Customersrv.italia@mattel.com - Numero verde 800 11 37 11. Mattel España, S.A., Aribau 200, 08036 Barcelona. cservice.spain@mattel.com Tel: 902203010 http://www.service.mattel.com/es. Mattel East Asia Ltd., Room 503-09, North Tower, World Finance Centre, Harbour City, Tsinghsatui, HK, China. Tel.: (852) 3185-6500. Diimport & Diedarkan Oleh: Mattel Continental Asia Sdn Bhd. Level 19, Tower 3, Avenue 7, No. 8 Jalan Kerinchi, Bangsar South, 59200 Kuala Lumpur, Malaysia. Mattel South Africa (PTY) LTD, Office 102 13, 30 Melrose Boulevard, Johannesburg 2196. Dystrybutor: Mattel Poland Sp. z o.o., Warsaw Trade Tower 34 p., ul. Chłodna 51, 00-867 Warszawa. Mattel Australia Pty. Ltd., 658 Church St., Richmond, Victoria, 3121. Consumer Advisory Service - 1300 135 312. Mattel AEBE, Εθνάρχου Μακαρίου 1, Κτηρίου Κ-2, ΚΤ 17561, Παλαιό Φάληρο. Mattel Oyuncakçılık Tic. Ltd. Şti. İçerenköy Mah., Erku Sok. A Blok No:12 Üner Plaza Kat:9-10 34752 Ataşehir İstanbul. Tel: 0216 570 75 00. Импортёр/Уполномоченная организация: ООО "МАТТЕЛ" Российская Федерация, 105120 Москва, 2-й Сыромятинский переулок, 1; +7 495 287 79 39. Forg.: Mattel Toys Hungary Kft 1139 Budapest Váci út 91. +36 1 270 0223. Mattel Czech Republic s.r.o., The Forum, Václavské nám. 19, 11000 Praha 1. Mattel, 333 Continental Boulevard, El Segundo, CA 90245, USA. Consumer Services: 1-800-465-MEGA (6342). Importado y distribuido por Mattel de México, S.A. de C.V., Miguel de Cervantes Saavedra No. 193, Pisos 10 y 11, Col. Granada, Alcaldía Miguel Hidalgo, C.P. 11520, México, Ciudad de México. R.F.C. MME-920701-NB3. Tels.: 59-05-51-00 Ext. 5206 ó 01-800-463-59-89. Mattel Chile, S.A., Avenida América Vespuccio 501-B, Quilicura, Santiago. Tel.: 1230-020-6213. Servicio al consumidor Venezuela: Tel.: 0-800-100-9123. Mattel Argentina, S.A., Av. Libertador 1000, Piso 11 – Oficinas 109 y 111, Vicente López – Prov. Buenos Aires. Tel.: 0800-666-3373. Mattel Colombia, S.A., Calle 12347-07 P5, Bogotá. Tel.: 01800-710-2069. Mattel Perú, S.A., Av. Juan de Arona n° 151, Centro Empresarial Juan de Arona, Torre C, Piso 7, Oficina 704, San Isidro, Lima 27, Perú. RUC: 20425853865. Reg. Importador: 02350-12-JUE-DIGESA. Tel.: 0800-54744. E-mail Latinoamérica: servicio.clientes@mattel.com. Mattel do Brasil Ltda. - CNPJ : 54.558.002/0001-20 - Rua Verbo Divino, 1488 - 2º Andar - 04719-904 - Chácara Santo Antônio - São Paulo - SP - Brasil. Serviço de Atendimento ao Consumidor: fone 0800 575 0780. E-mail: sac.matteldobrazil@mattel.com

⚠ WARNING :
CHOKING HAZARD. - Small parts.
Not for children under 3 years.

⚠ ATTENTION :
DANGER D'ÉTOUFFEMENT. - Présence de petits éléments.
Ne convient pas aux enfants de moins de 3 ans.

⚠ 警告:
のどにつまる危険 小さな部品が含まれています
3歳以下の子供には与えないで下さい。

⚠ تحذير:
غير مناسبة للأطفال دون 36 شهراً - قطع صغيرة.

⚠ **警告!**
不适合3岁以下儿童使
用。内含小零件。

ADVERTENCIA: PELIGRO DE ATRAGANTAMIENTO. Juguete no recomendado para menores de 3 años, porque contiene piezas pequeñas que podrían provocar asfixia en caso de ser ingeridas o inhaladas por el/la niño/a.

ATENÇÃO! Não indicado / não recomendável para crianças menores de 3 (três) anos por conter parte(s) pequena(s) que pode(m) ser engolid(a)s ou aspirada(s) podendo provocar asfixia.

AVVERTENZA: Contiene pezzi di piccole dimensioni.

ACHTUNG: Kleine Teile.

OSTRZEŻENIE: Małe części. Niebezpieczeństwo zadławienia.

WAARSCHUWING: Kleine onderdelen

ПРЕДУПРЕЖДЕНИЕ: Мелкие детали.

ADVARSEL: Indeholder små dele.

VARNING: Smådelar

ADVARSEL: Små deler

VAROITUS: Pieniä osia

ΠΡΟΣΟΧΗ: Περιλαμβάνονται μικρά κομμάτια.

UYARI: Küçük parçalar.

UPOZORNĚNÍ: Malé díly

UPOZORNENIE: Malé časti

FIGYELMEZTETÉS: Kis alkatrészek.



MEGA



JOUETS DE
CONSTRUCTION
SETS DE
CONSTRUCCIÓN

CONJUNTOS DE CONSTRUÇÃO
BAUSETS • НАБОРЫ КОНСТРУКТОРОВ

TWINDUCTION HAULER PACK™
COFFRET TRANSPORTEUR TWINDUCTION
SET REMOLQUE TWINDUCTION
CONJUNTO REBOQUE TWINDUCTION



MORE TO BUILD! ENCORE PLUS À CONSTRUIRE!

¡MÁS PARA CONSTRUIR! • MAIS PARA CONSTRUIR!
MEHR ZUM BAUEN! • КОНСТРУИРУЙ БОЛЬШЕ!



Set(s) sold separately and subject to availability. / Ensemble(s) vendu(s) séparément. Certains produits peuvent ne pas être commercialisés. / Se vende(n) por separado y está(n) sujeto(s) a disponibilidad. / Conjunto(s) vendido(s) em separado e sujeito(s) à disponibilidade. / Set in vendita separatamente, secondo disponibilità. / Das/Die Set(s) sind separat erhältlich. / Zestaw(y) sprzedawany(e) oddzielnie w zależności od dostępności. / Set(s) apart verkrijgbaar en afhankelijk van beschikbaarheid. / Набор(-ы) продаются отдельно, при наличии. / Sæt sælges separat og så længe lager haves. / Seten säljs separat så länge lagret räcker. / Settet/settene selges separat så langt lageret rekker. / Pakkaus/pakkaukset myydään erikseen, saatavuus voi vaihdella. / Το(α) σετ πωλούνται ξεχωριστά και ανάλογα με τη διαθεσιμότητα. / Setler ayrı olarak satılır ve stoklarla sınırlıdır. / Set (sety) se prodává (prodávají) samostatně dle aktuální nabídky. / Súprava-/y sa predáva(jú) samostatne a podľa dostupnosti. / A készlet(ek) külön kapható(k), az elérhetőség változhat. / セット商品は別売りになります。在庫状況は別途ご確認をお願いします。 / تبايع المجموعة أو المجموعات على حدة وتخضع لتوافرها.

每套单独发售，按供货情况决定。

1186 MJ, 1, NL

© 2020, MEGA Brands &™ MEGA Brands; HOT WHEELS and associated trademarks and trade dress are owned by and used under license from Mattel. HOT WHEELS ainsi que les marques et designs y afférents appartiennent à, et sont utilisés sous licence de Mattel. © 2020 Mattel.

Printed in China / Imprimé en Chine AD-GYG66-01A

10+
PRO
BUILDERS™

Are you ready for
the next challenge?
Prêt pour le
prochain défi?

¿Estás listo para el siguiente desafío?
Você está pronto para o próximo desafio?
Bist du bereit für die
nächste Herausforderung?
Вы готовы к следующему испытанию?



Mattel Canada Inc. Mississauga,
Ontario L5R 3W2.

MADE IN CHINA. FABRIQUÉ EN CHINE.

FABRICADO NA / HECHO EN CHINA.

ИЗГОТОВЛЕНО В КИТАЕ. ÇIN'DE ÜRETİLMİŞTİR.

صنع في الصين



MEGA
CONSTRUX

HotWheels



**BUILD IT!
CONSTRUIS LE !**
¡Constrúyelo!
Você pode construí-lo!
Mega Bauspaß! / Построй!

WONDER
BUILDERS

GYG66

HAULER · TRANSPORTEUR
REMOLQUE · REBOQUE



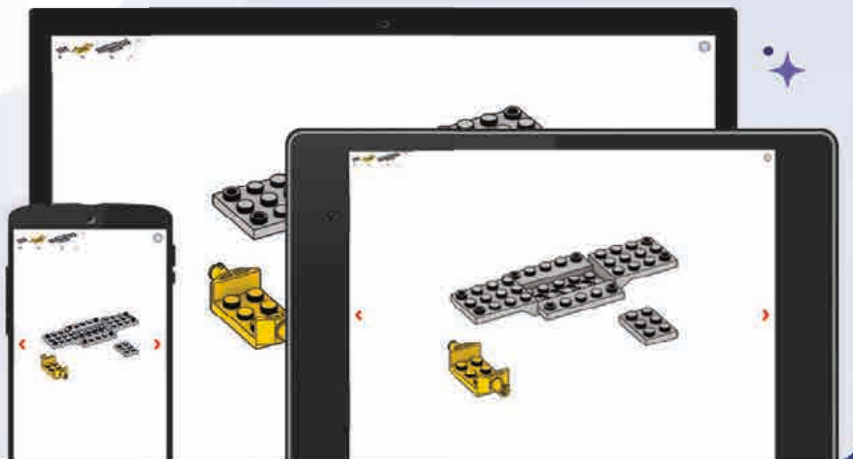

Scan here for instructions
Scanner ici pour
obtenir les instructions

Escanee aquí para
obtener instrucciones
Digitalize aqui para instruções
Hier scannen und Anleitung aufrufen
Просканируйте здесь
для получения инструкций



play.megaconstrux.com

1



1



2



2

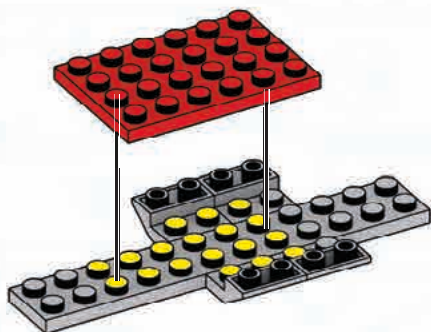
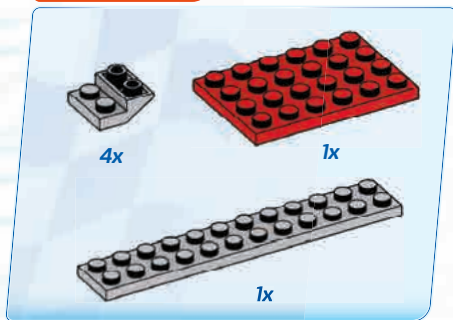

3

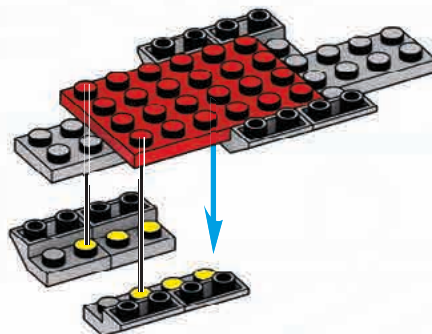



HAULER · TRANSPORTEUR

REMOLQUE · REBOQUE

4



1x



1x

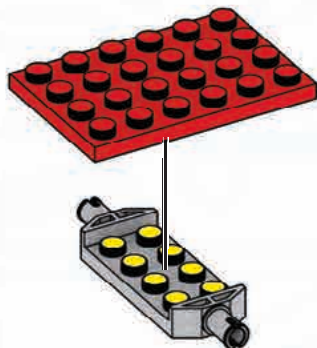

5



1x

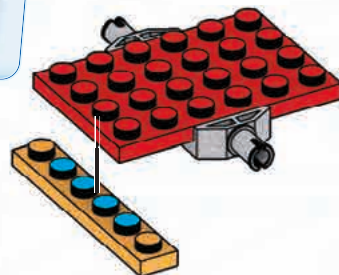

6



2x

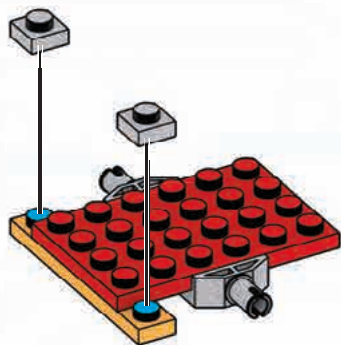

7

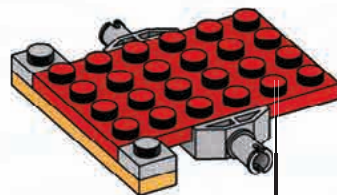

3



8



1x



1x

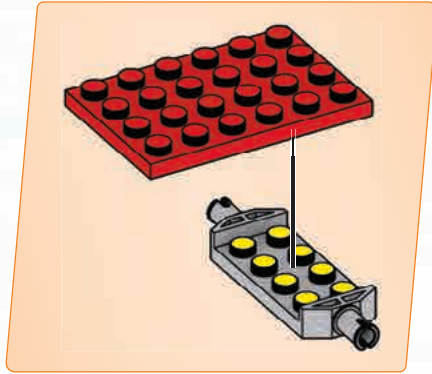

9



2x

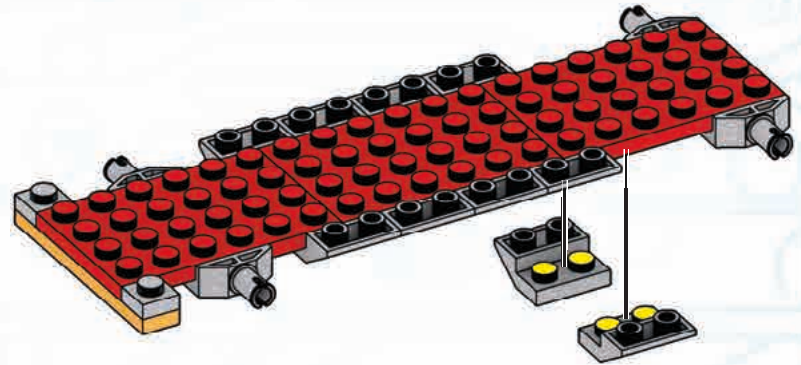
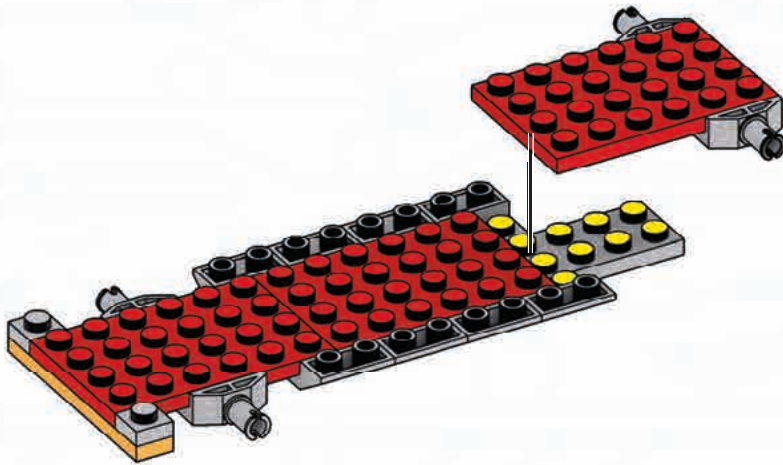



HAULER · TRANSPORTEUR

REMOLQUE · REBOQUE

10



2x

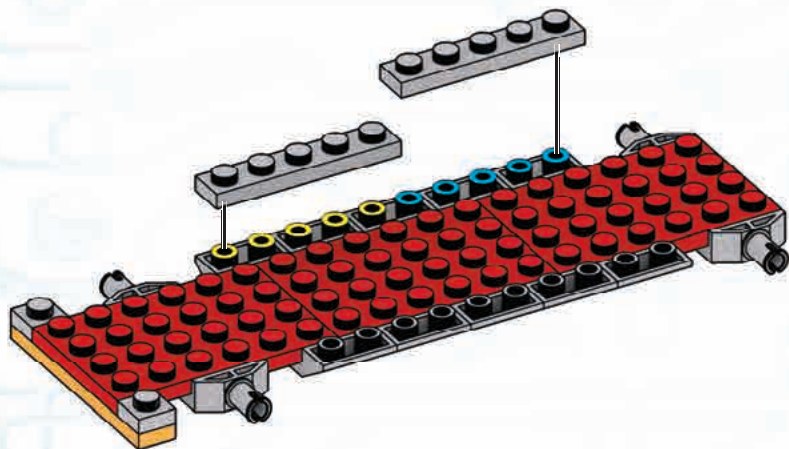

11



2x

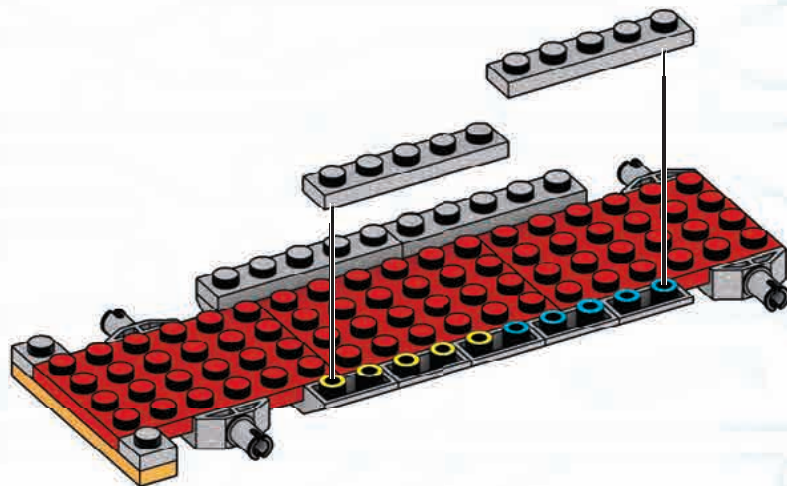

12



2x

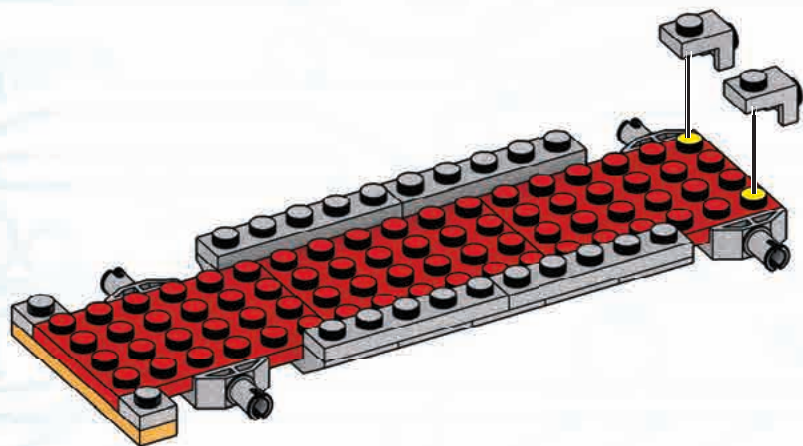

13



2x

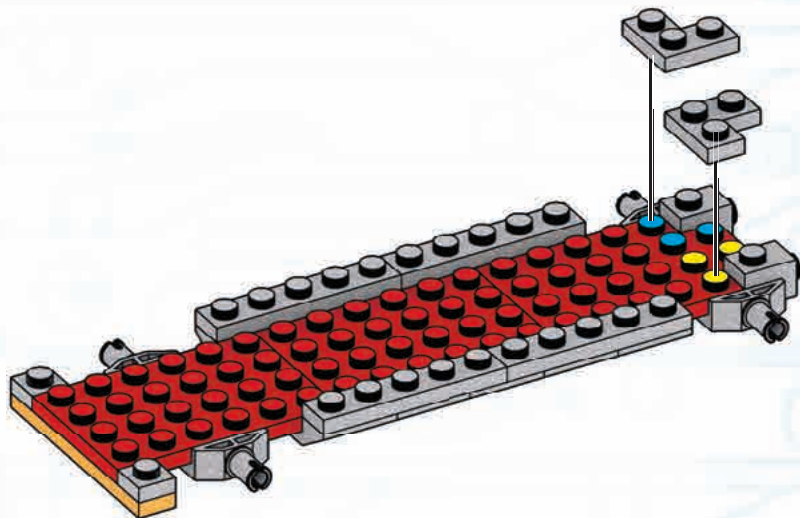



HAULER · TRANSPORTEUR

REMOLQUE · REBOQUE

14



1x

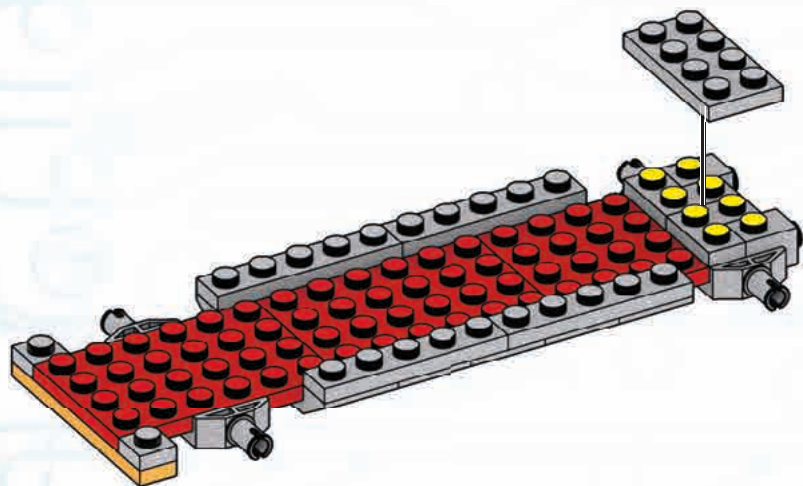

15



1x



1x

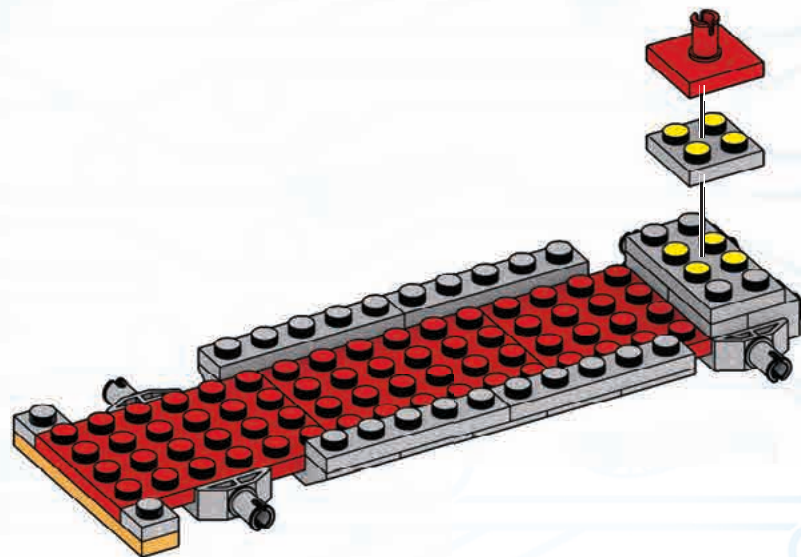

16

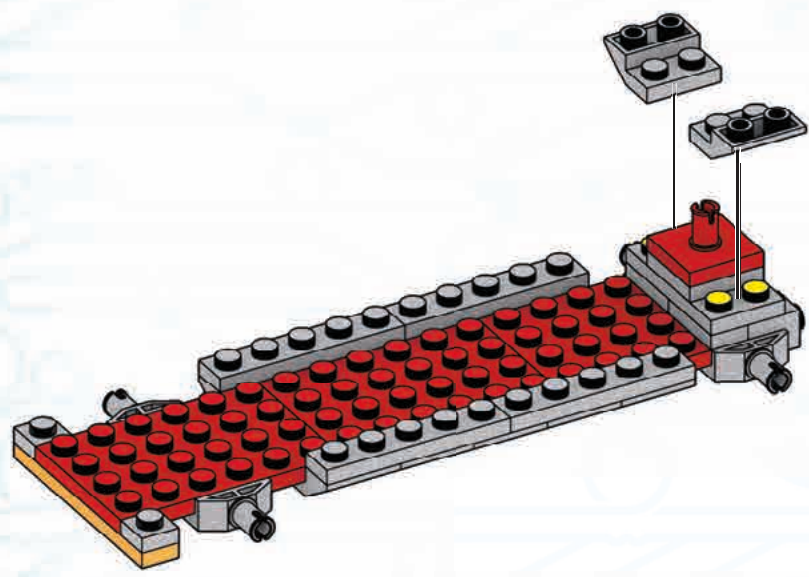

17

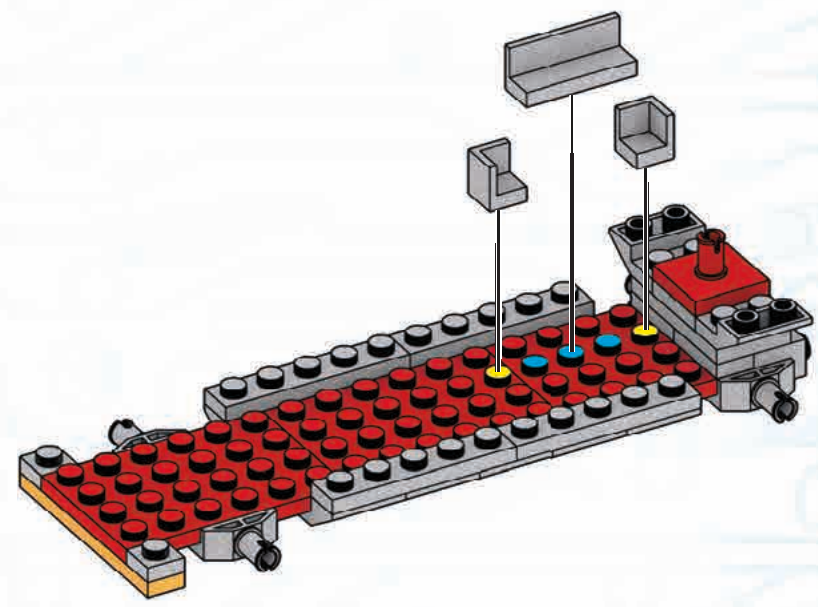
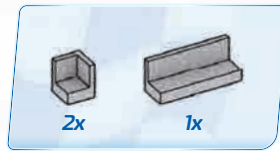



HAULER · TRANSPORTEUR

REMOLQUE · REBOQUE

18



2x



1x

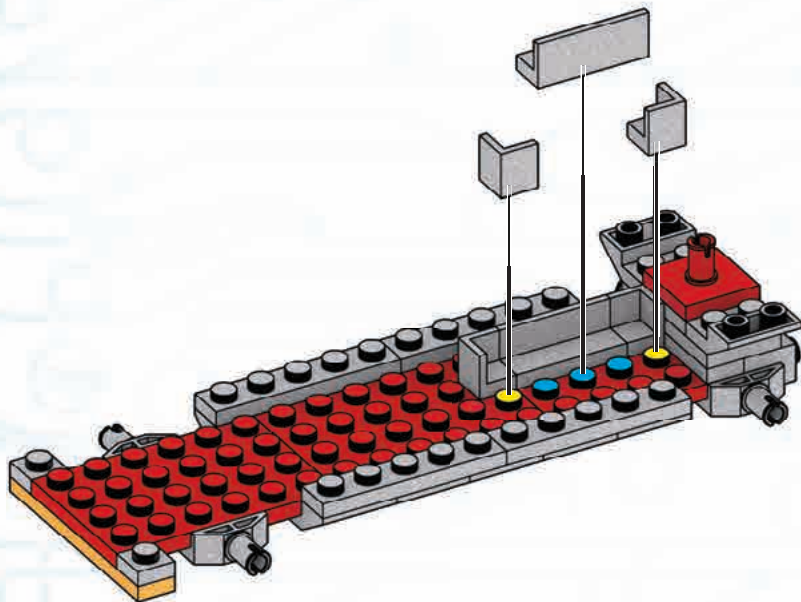

19



1x



2x

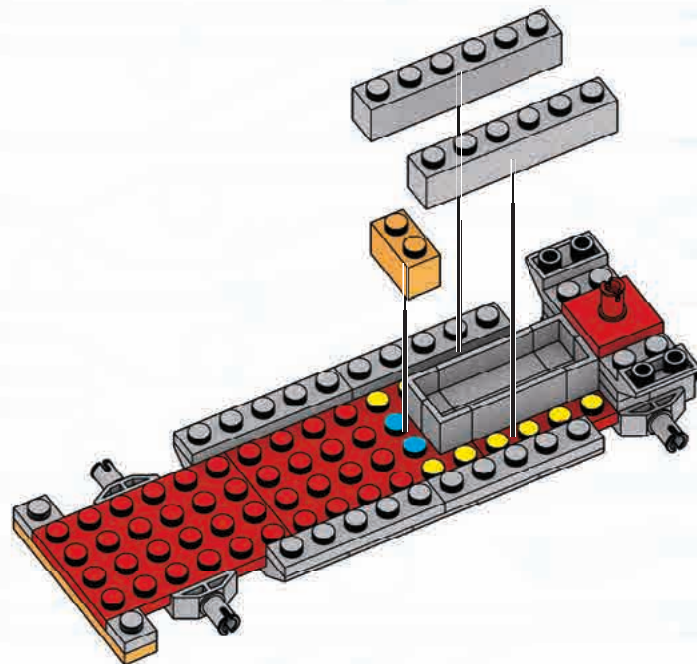

20



2x

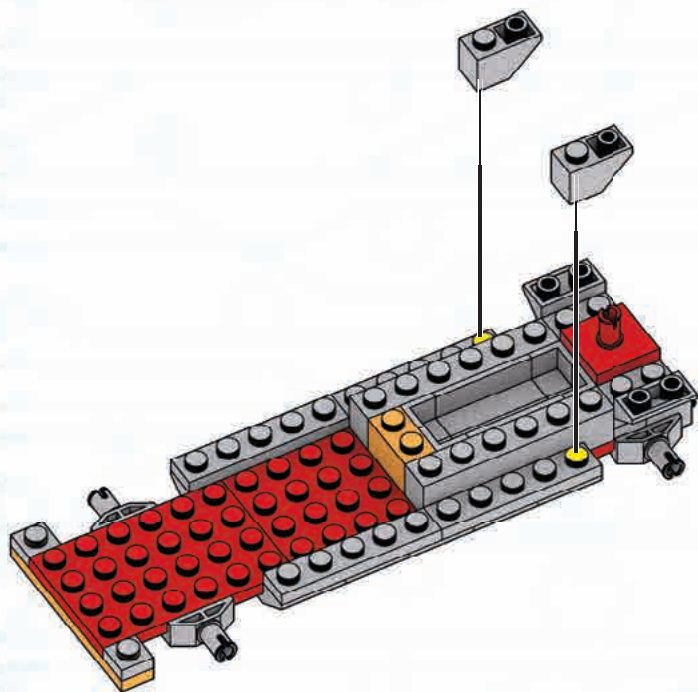

21



2x

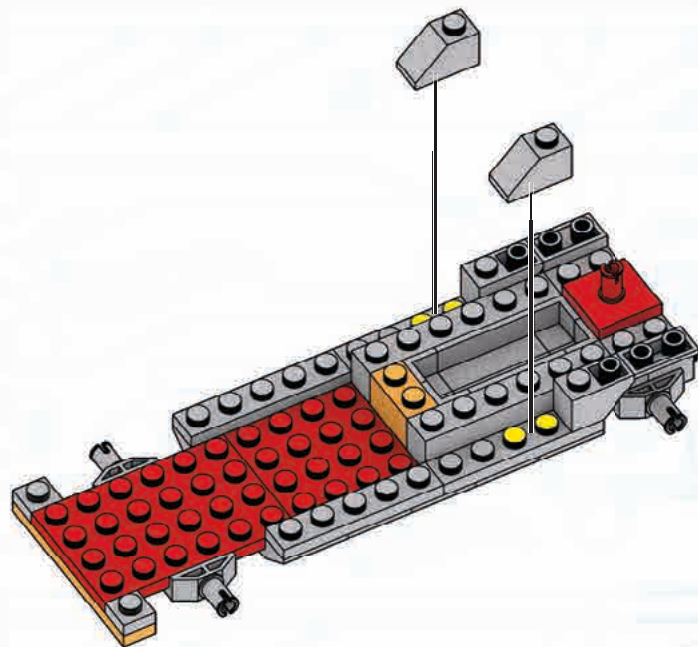



HAULER · TRANSPORTEUR

REMOLQUE · REBOQUE

22



1x



1x

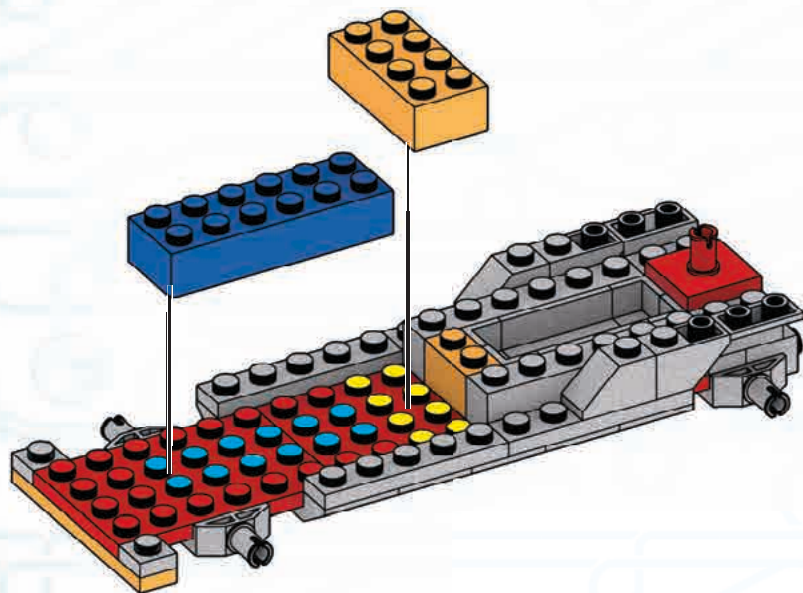

23



2x

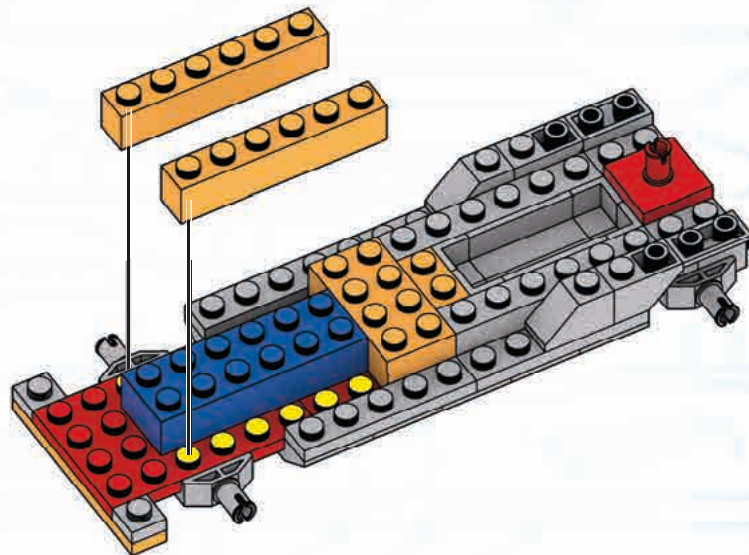

24

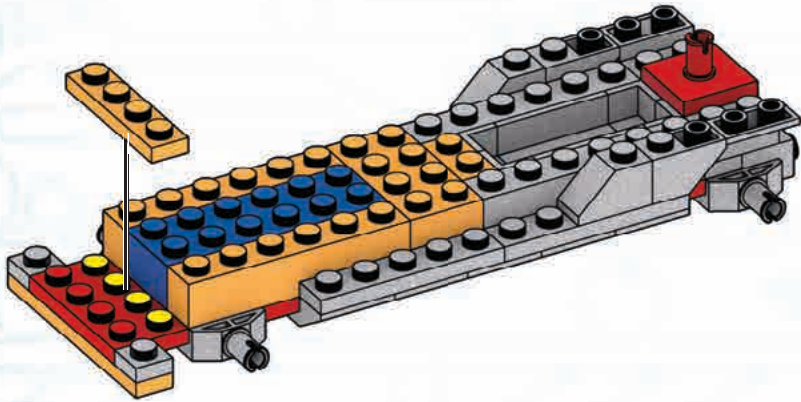

25

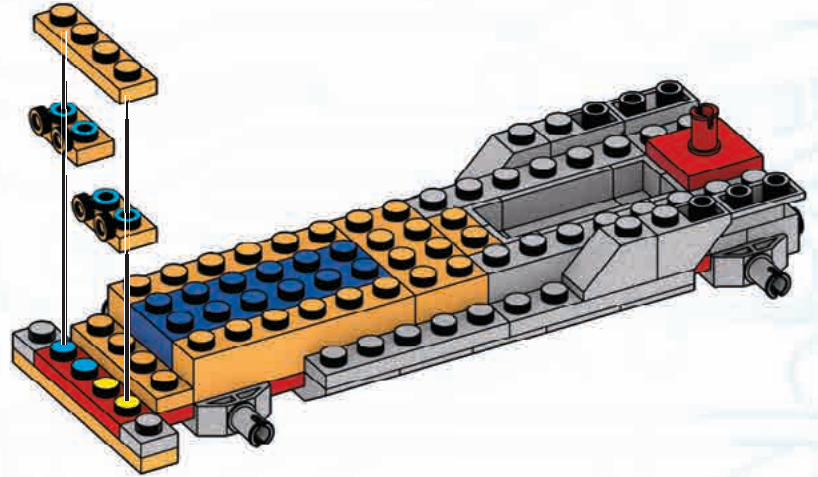



HAULER · TRANSPORTEUR

REMOLQUE · REBOQUE

26



1x

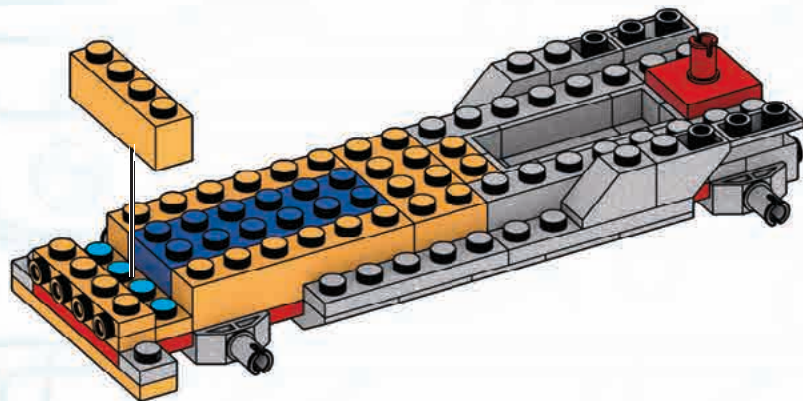

27



2x

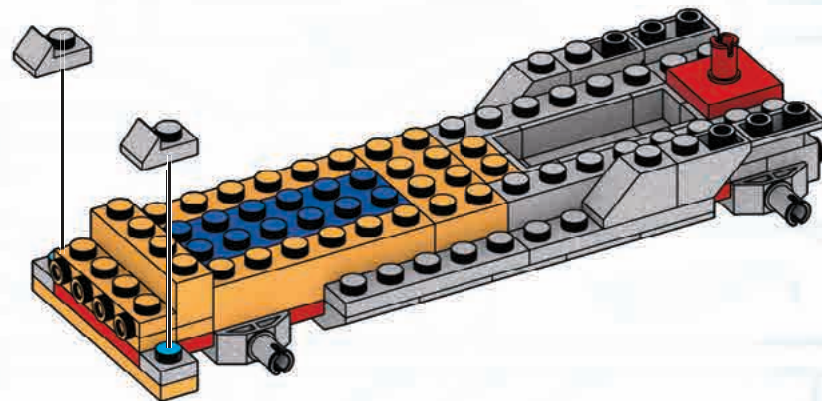

28

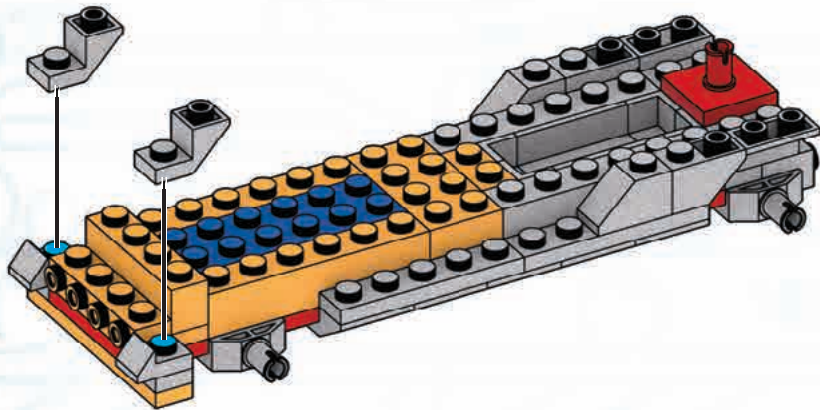

29

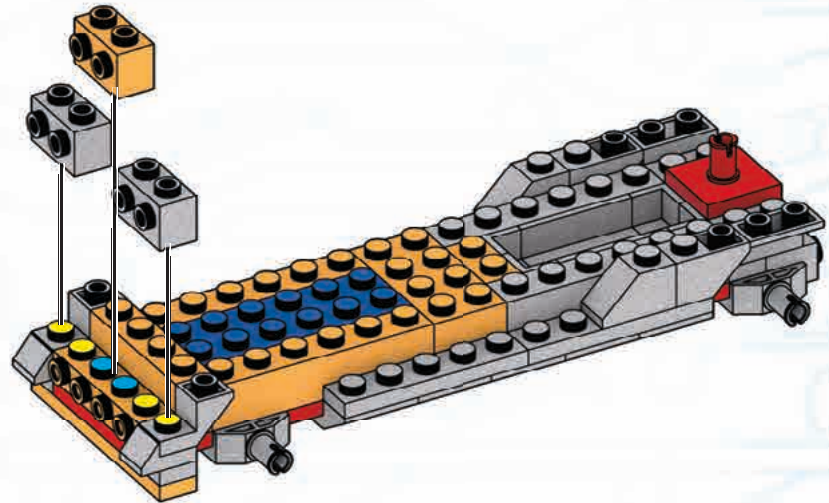
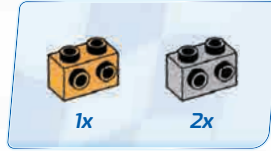



HAULER · TRANSPORTEUR

REMOLQUE · REBOQUE

30



2x

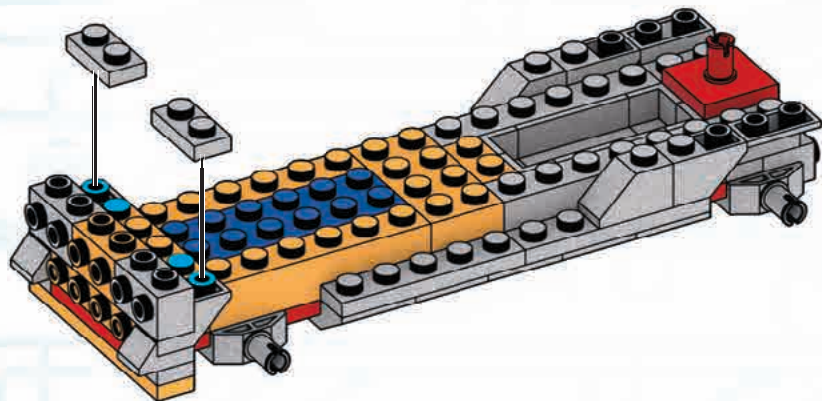

31



2x

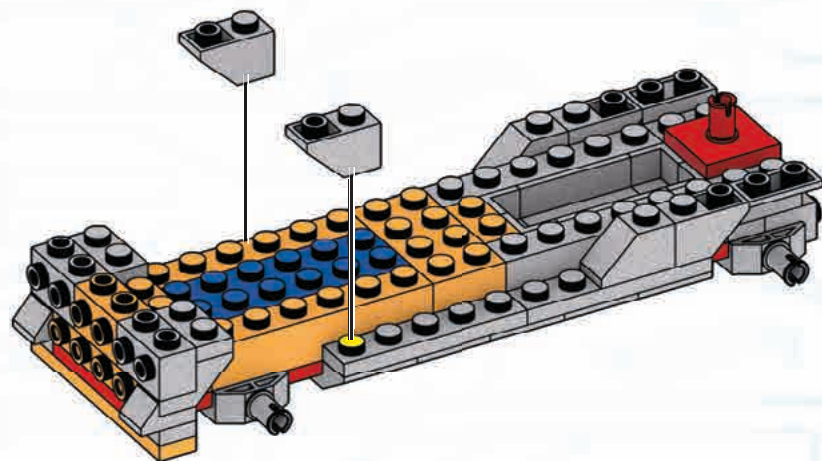

32



3x

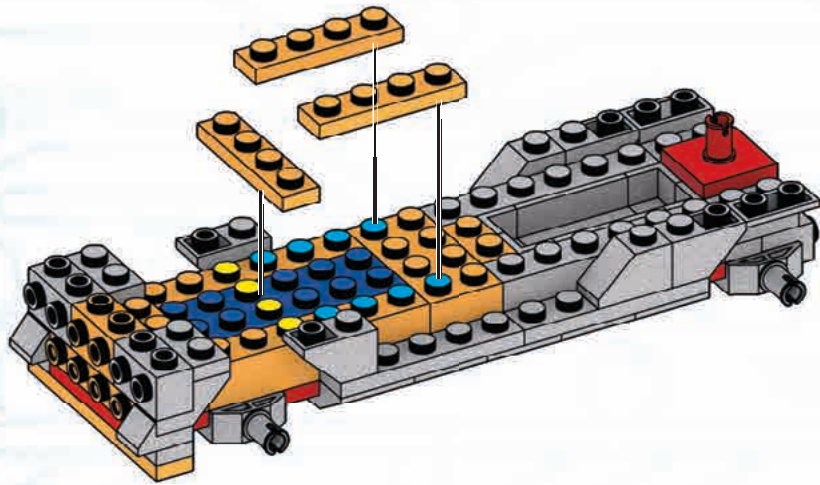

33



1x



1x

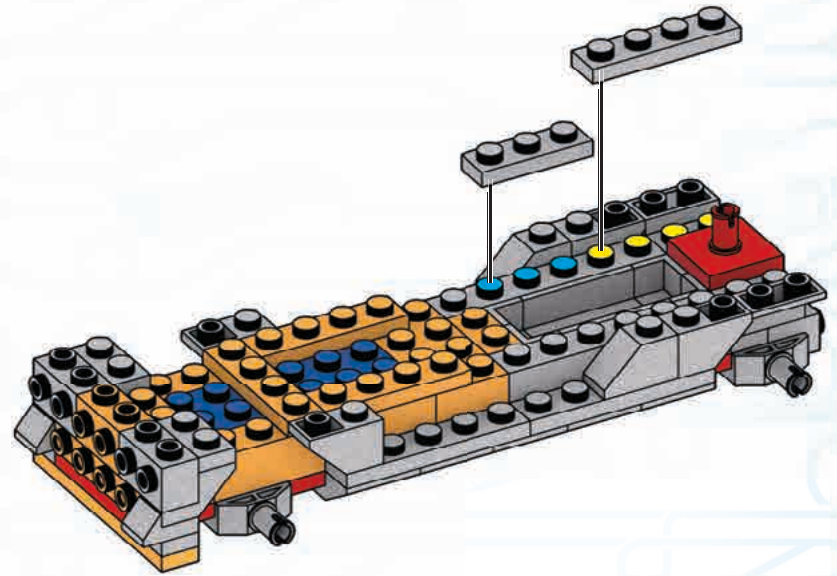



HAULER · TRANSPORTEUR

REMOLQUE · REBOQUE

34



1x

1x

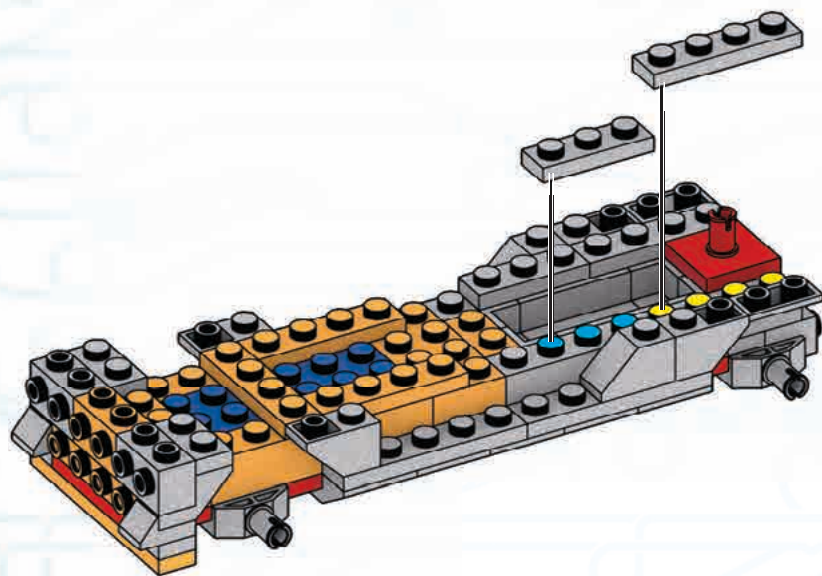

35



1x

1x

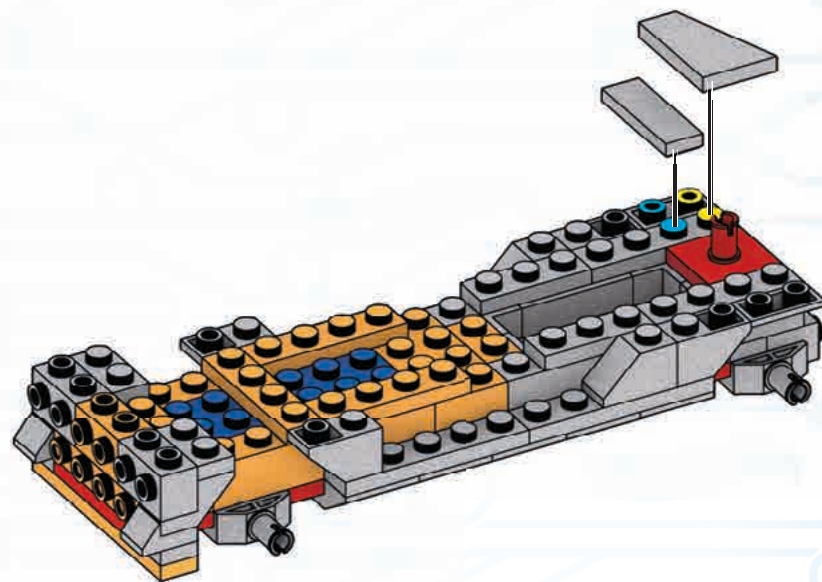

36



1x



1x

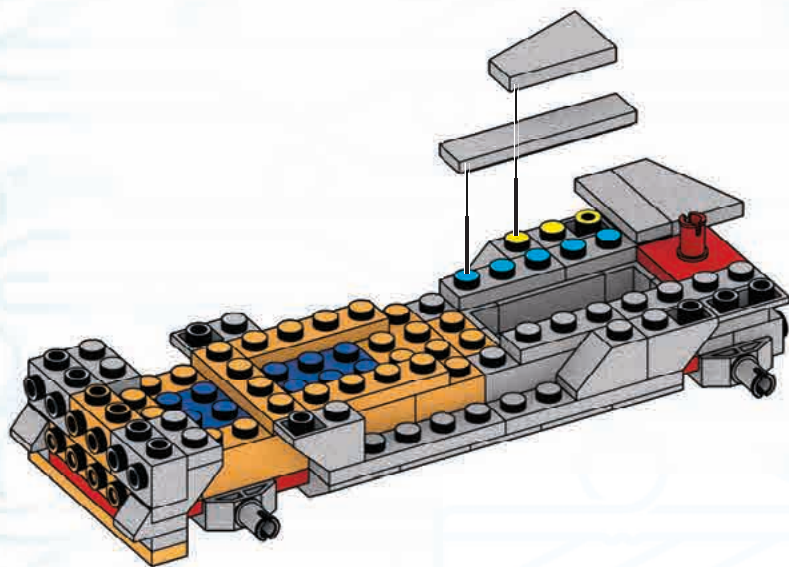

37



1x



1x

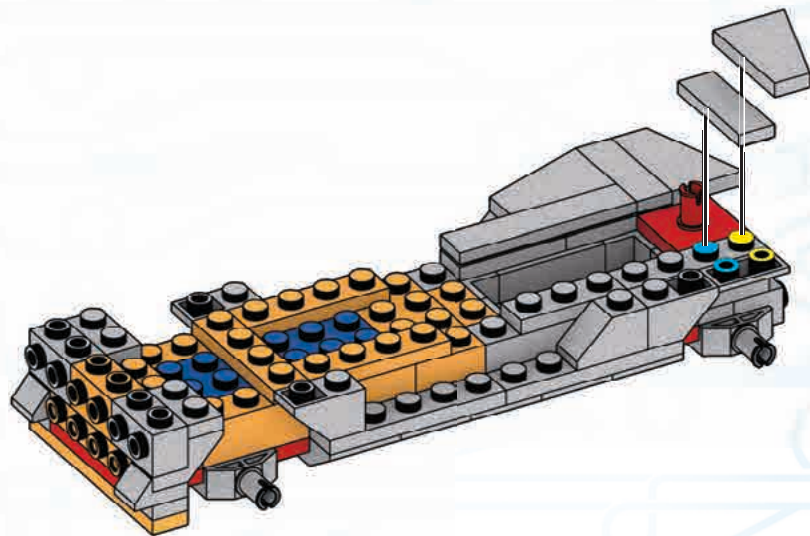



HAULER · TRANSPORTEUR

REMOLQUE · REBOQUE

38



1x



1x

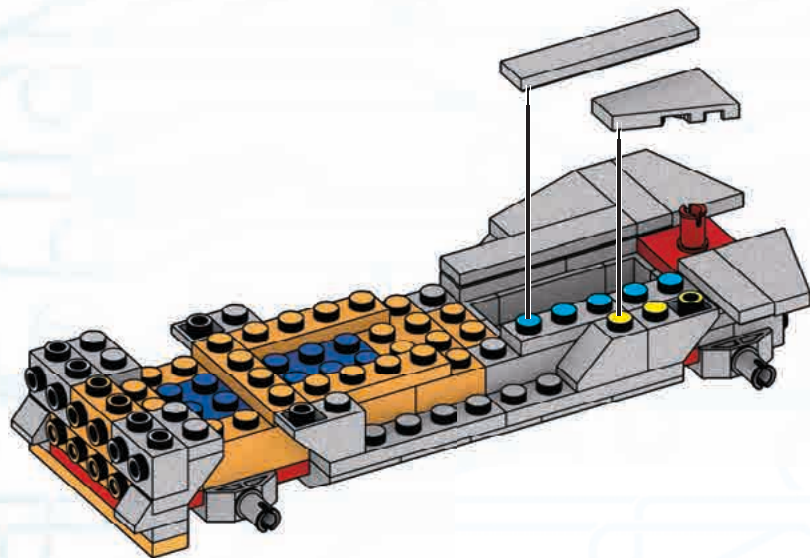

39



1x



1x

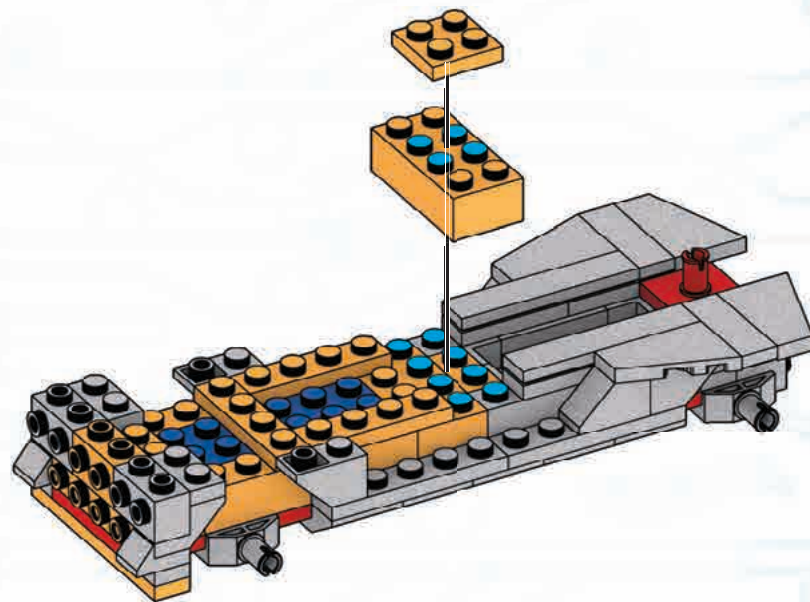

40



2x

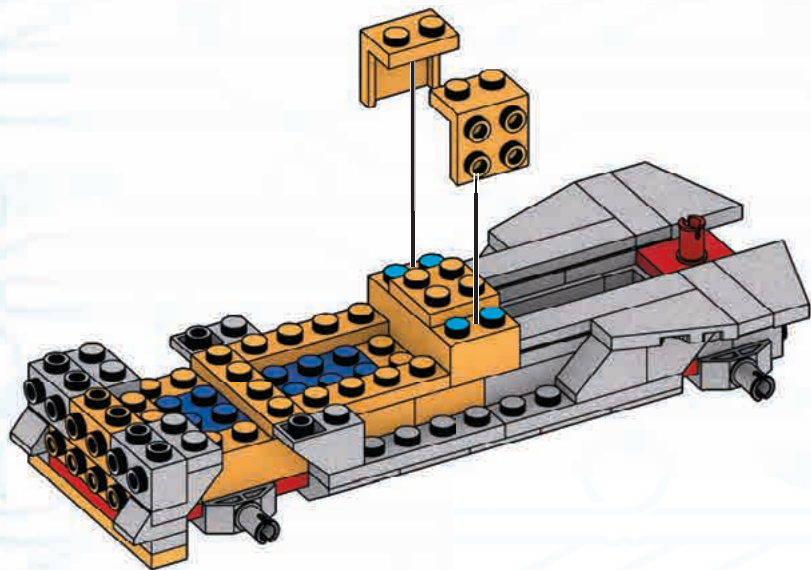

41



1x

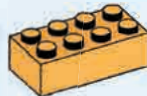

1x

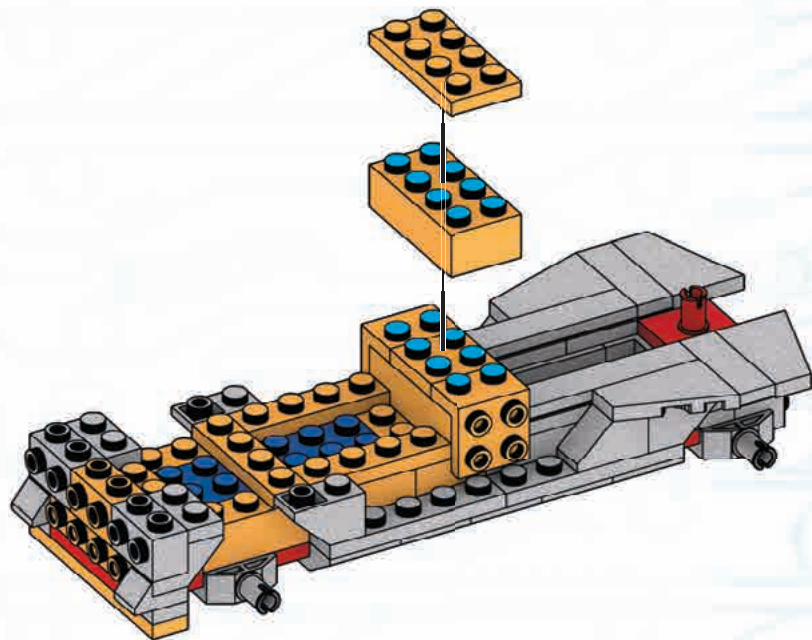



HAULER · TRANSPORTEUR

REMOLQUE · REBOQUE

42



1x

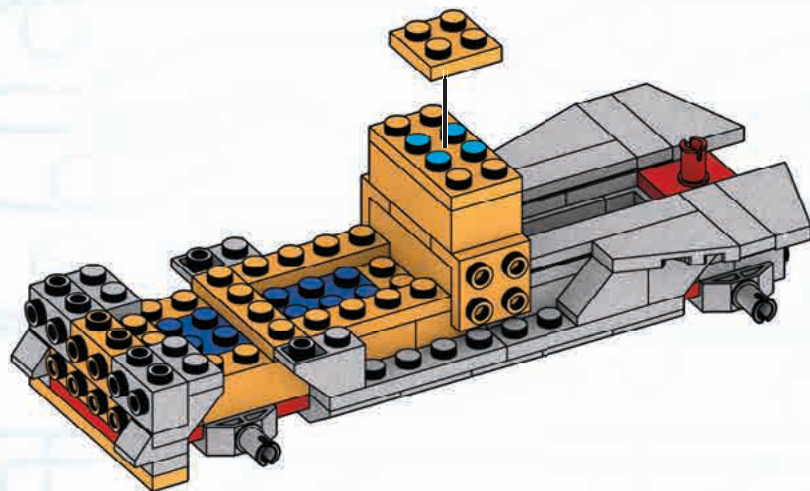

43



2x

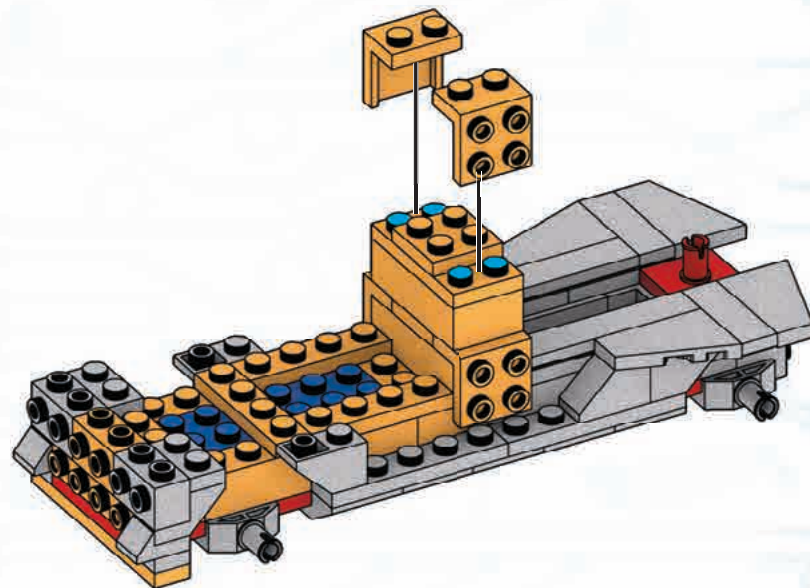

44



1x

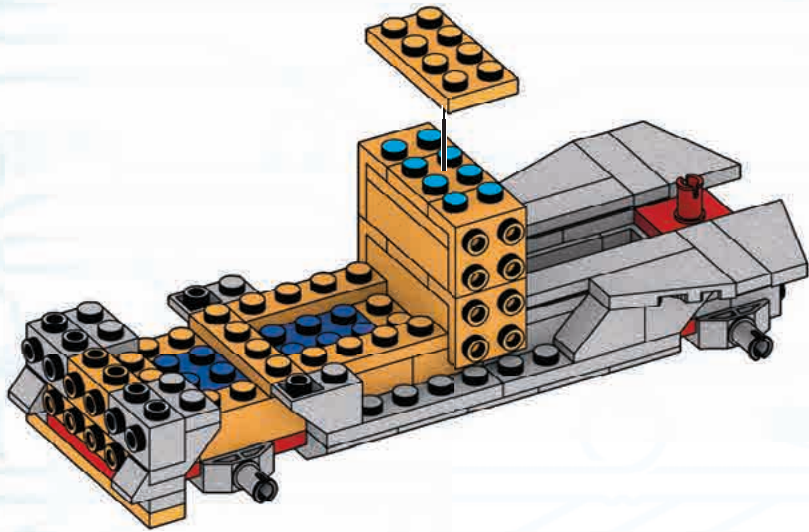

45



2x



1x

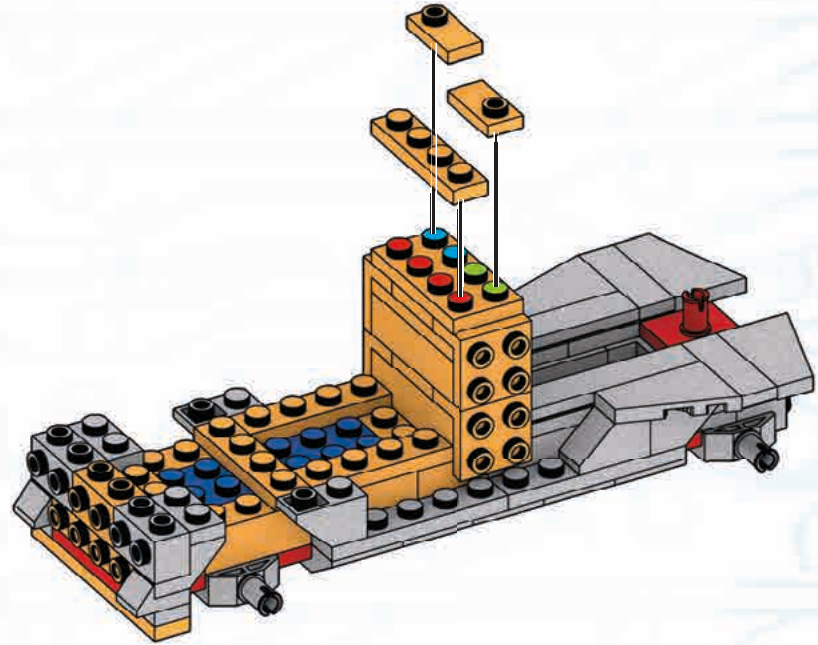



HAULER - TRANSPORTEUR

REMOLQUE - REBOQUE

46



2x

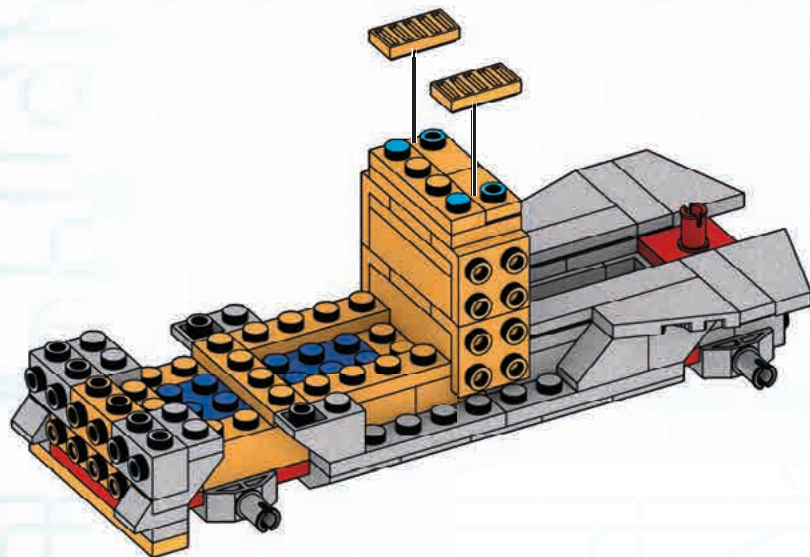

47



1x

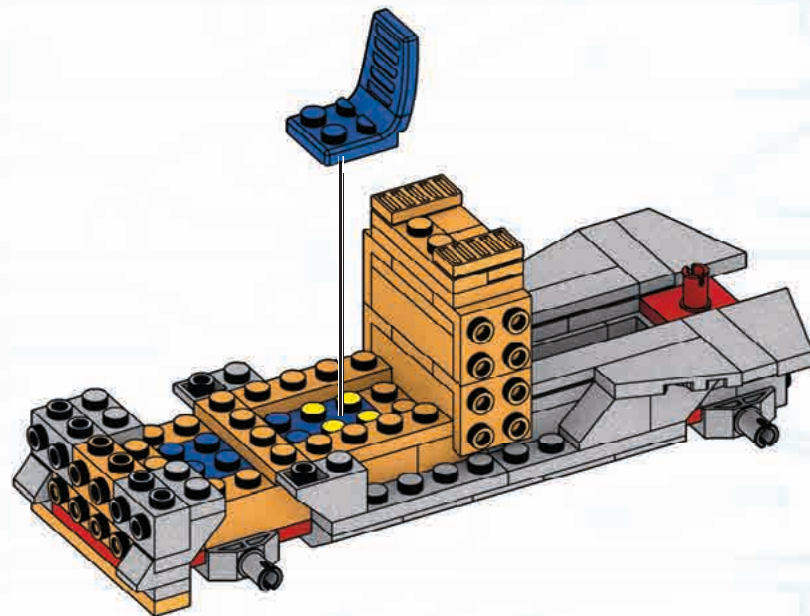

48



2x

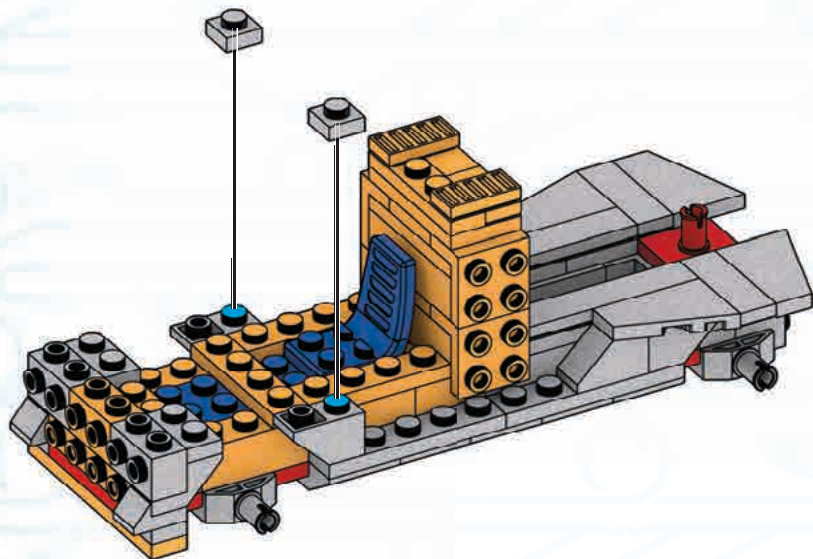

49



2x

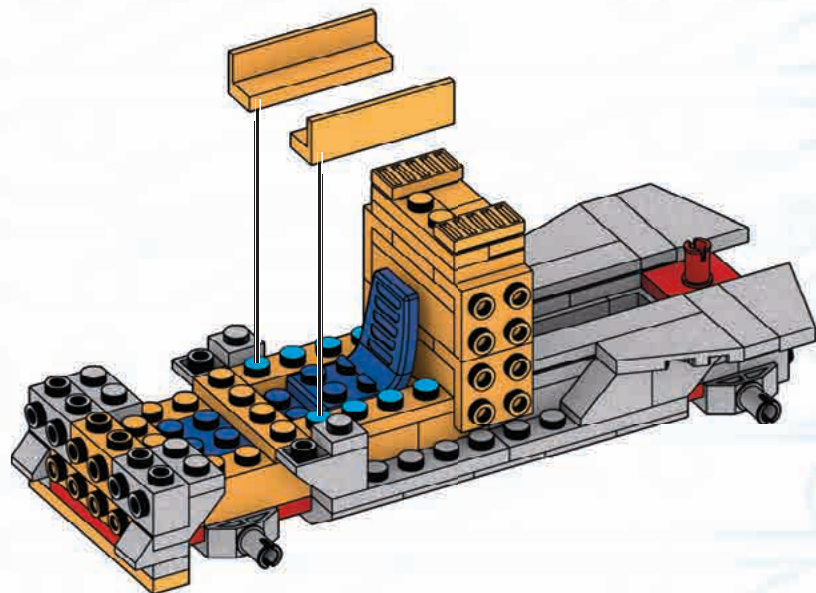



HAULER · TRANSPORTEUR

REMOLQUE · REBOQUE

50



1x

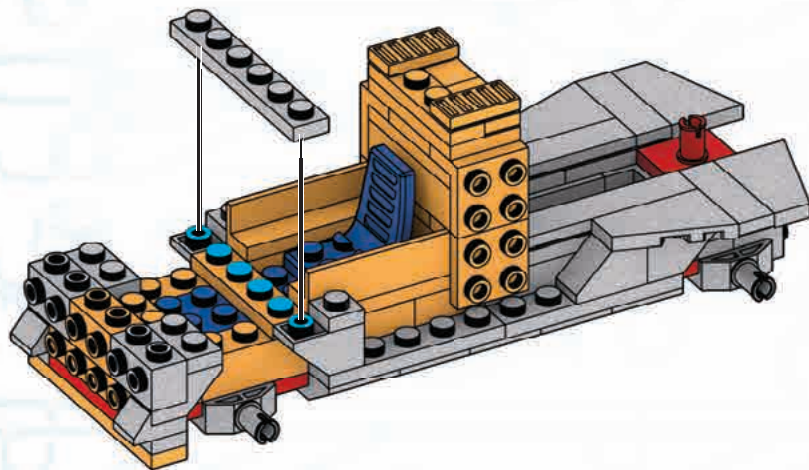

51



2x

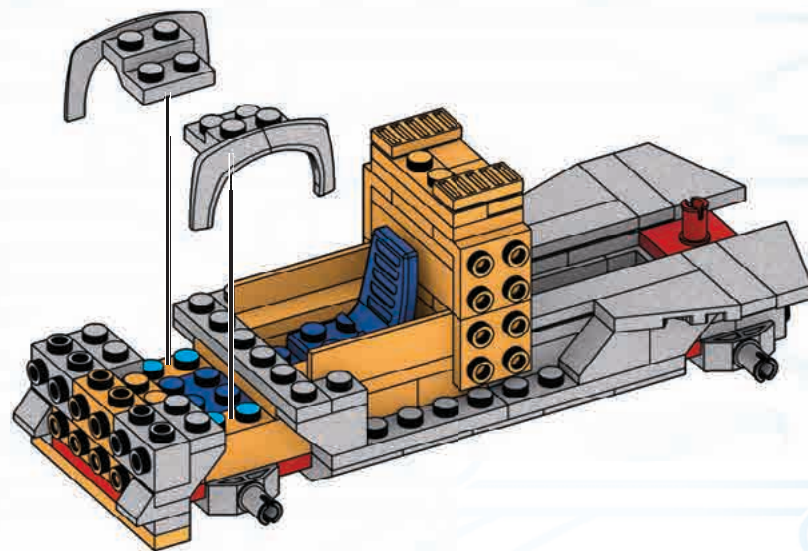

52



1x

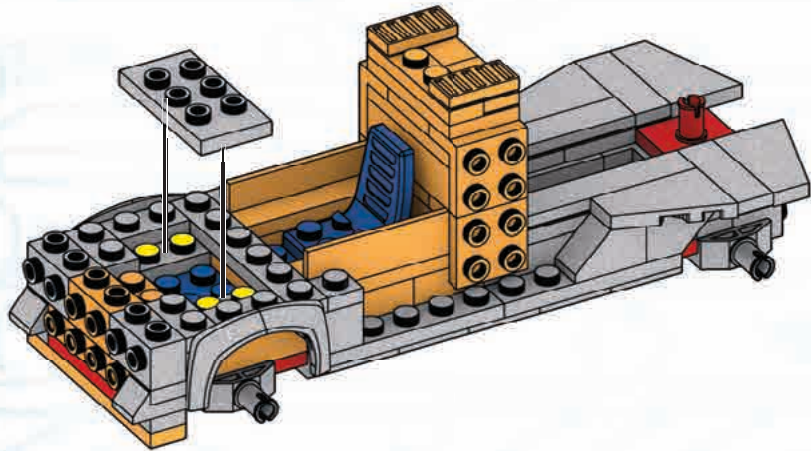

53



2x



1x

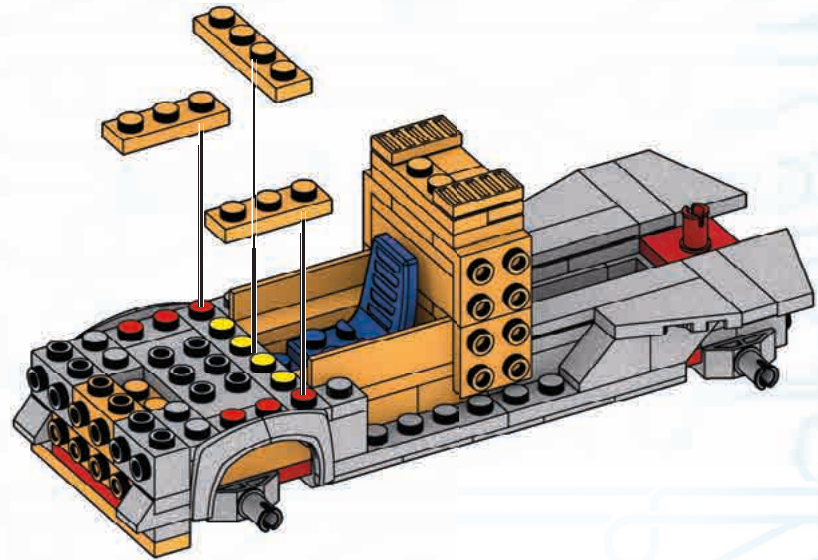



HAULER - TRANSPORTEUR

REMOLQUE - REBOQUE

54



1x



1x

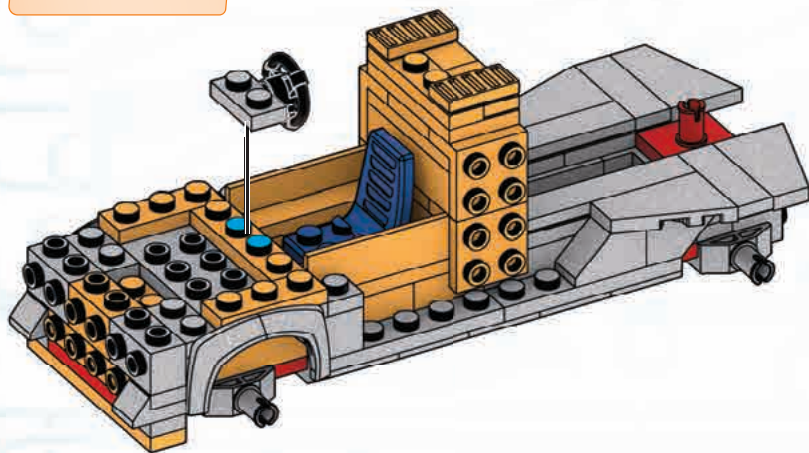

55



2x

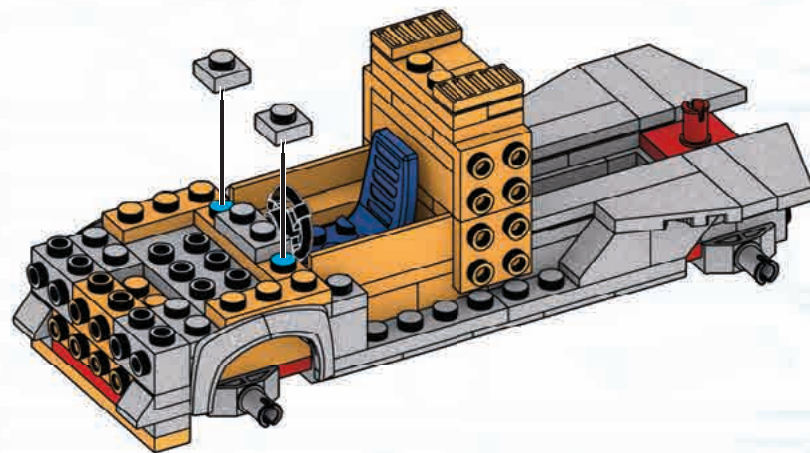

56

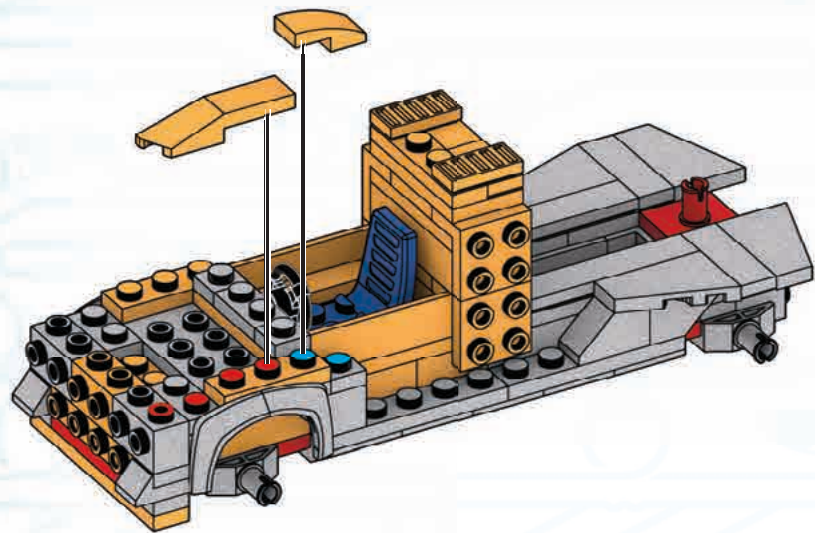
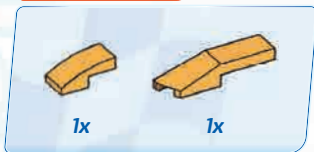

57

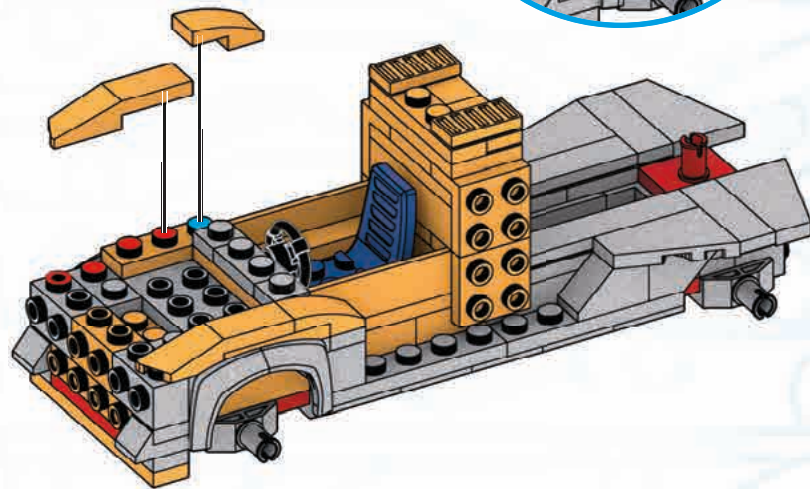
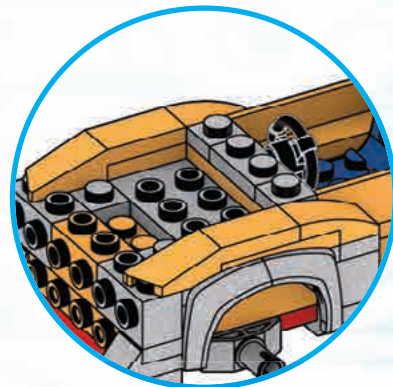
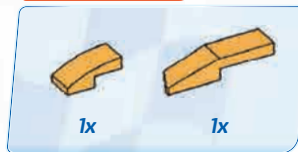



HAULER · TRANSPORTEUR

REMOLQUE · REBOQUE

58



1x

1x

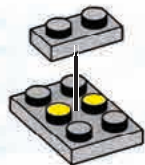

59



1x

1x

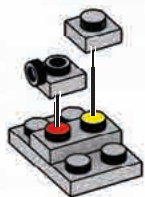

60



1x

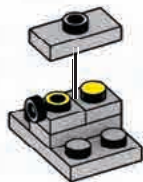

61



1x

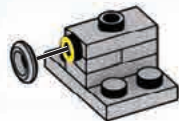

62



2x



63



1x



1

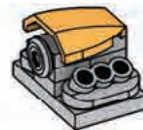

2

64

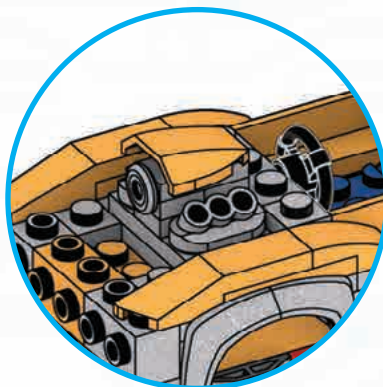
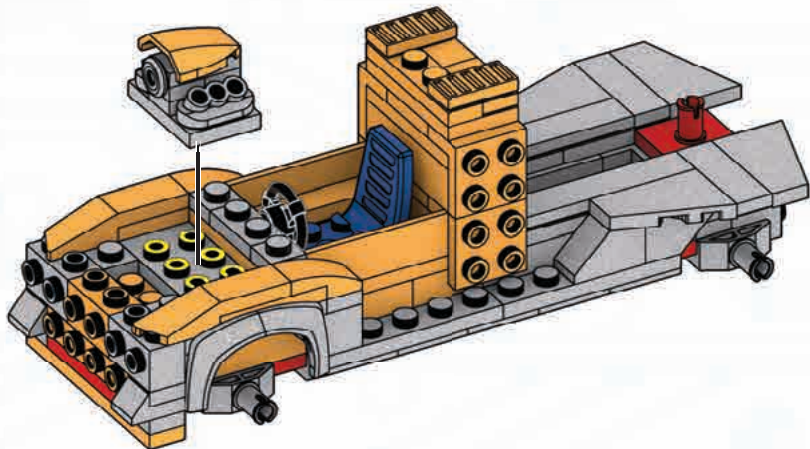

65



2x

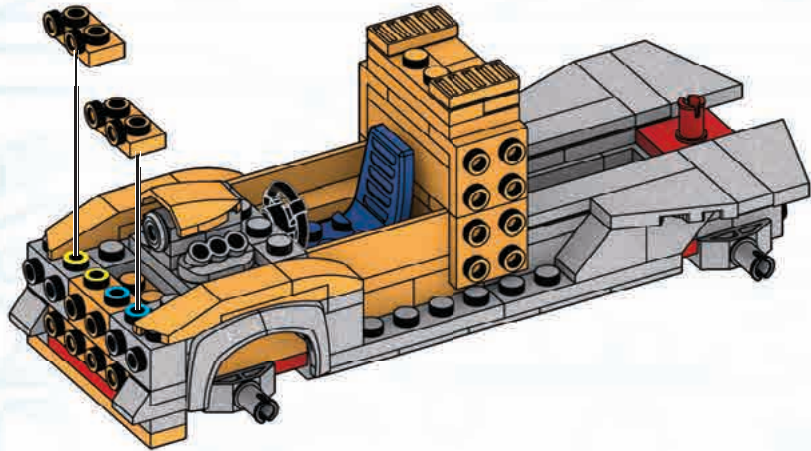

66



2x

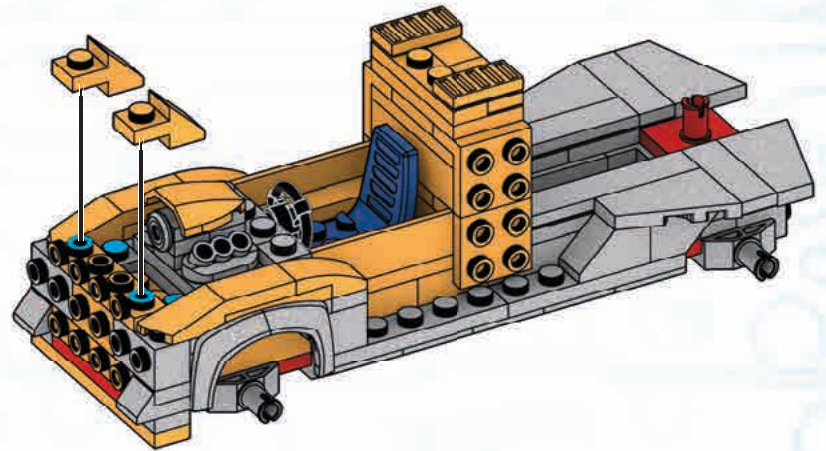



HAULER · TRANSPORTEUR

REMOLQUE · REBOQUE

67



2x

68



2x

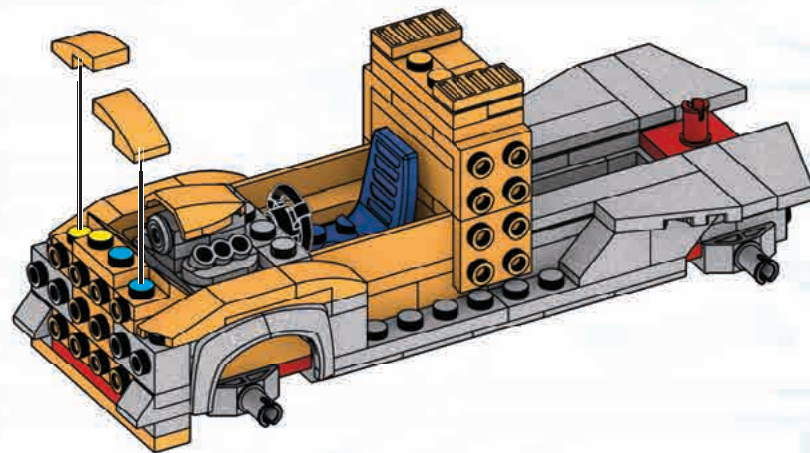
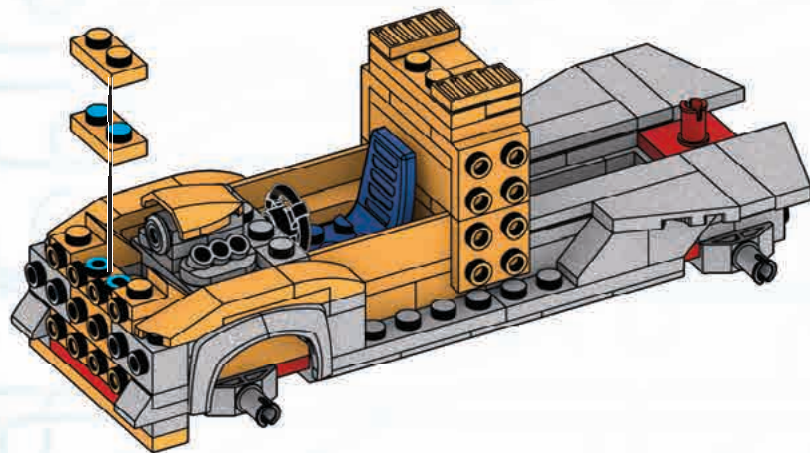

69

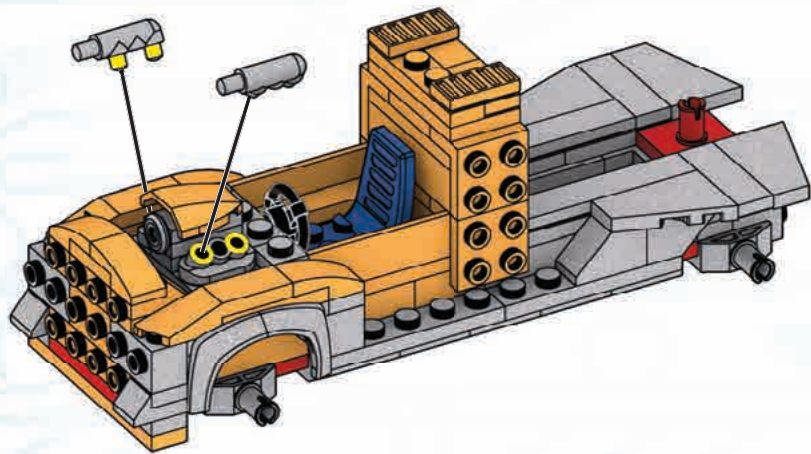

70

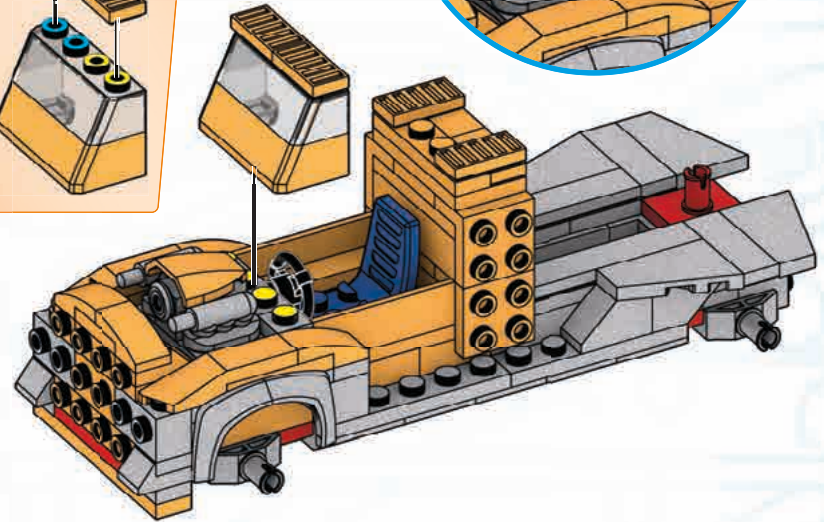
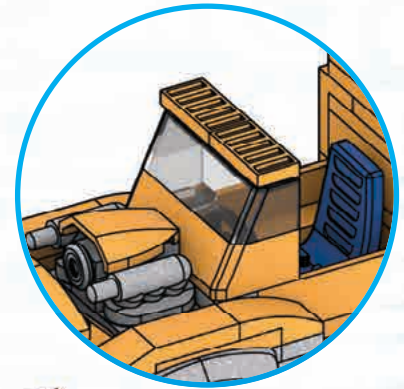
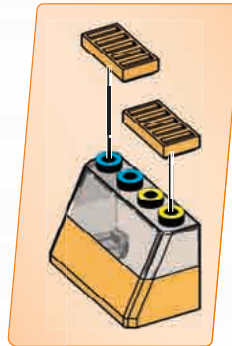
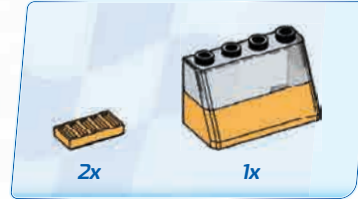



HAULER · TRANSPORTEUR

REMOLQUE · REBOQUE

71



1x

1x

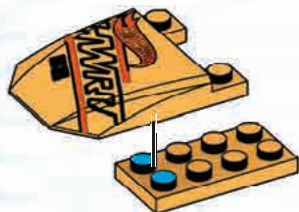

75



1x

72



1x

1x

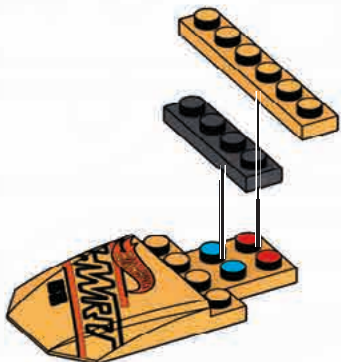

73



1x

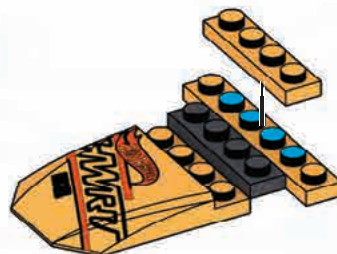

74



1x

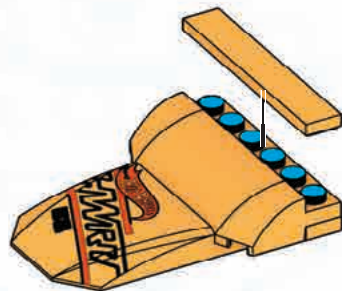
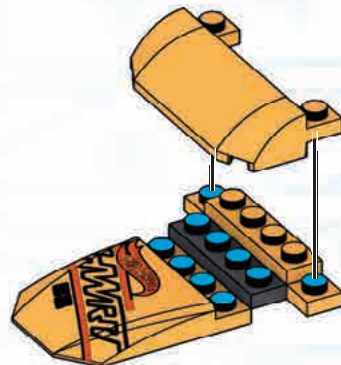

1



2

76

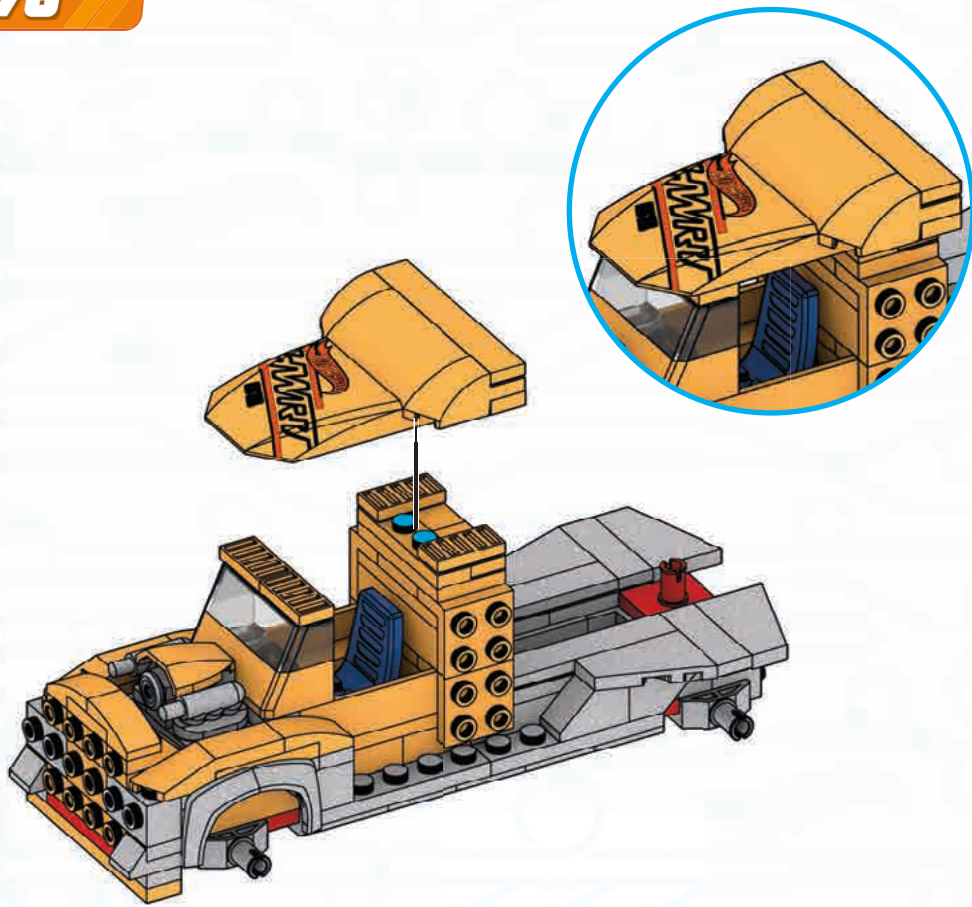

77

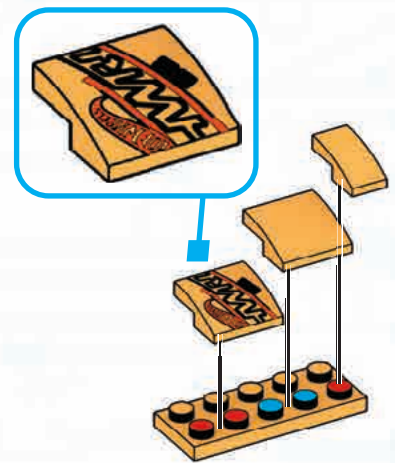
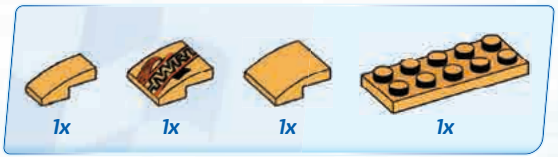



HAULER · TRANSPORTEUR

REMOLQUE · REBOQUE

78



1x

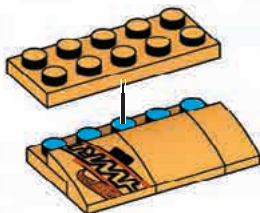

79



1x



1x

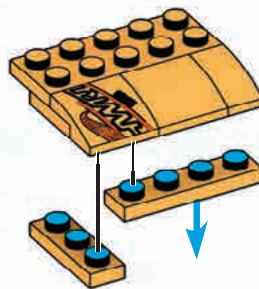

1



2

80

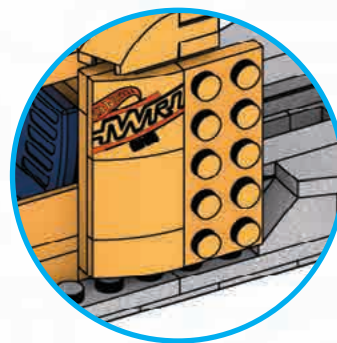
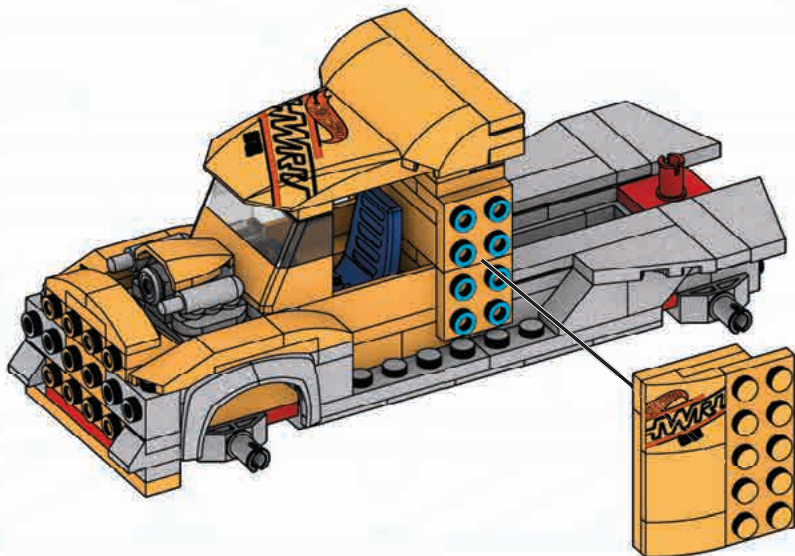

81

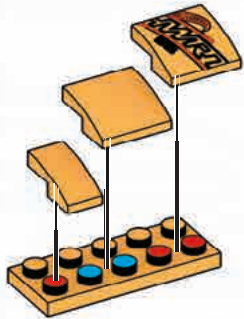

82

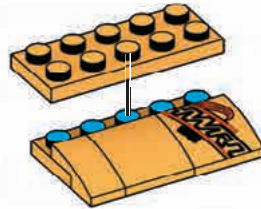

83

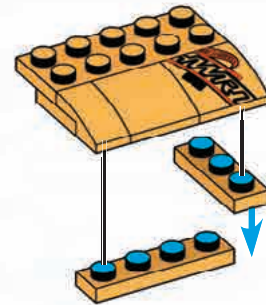

1



2



HAULER - TRANSPORTEUR

REMOLQUE - REBOQUE

84

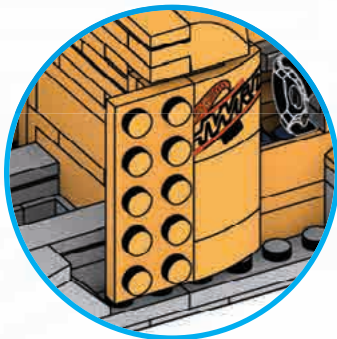
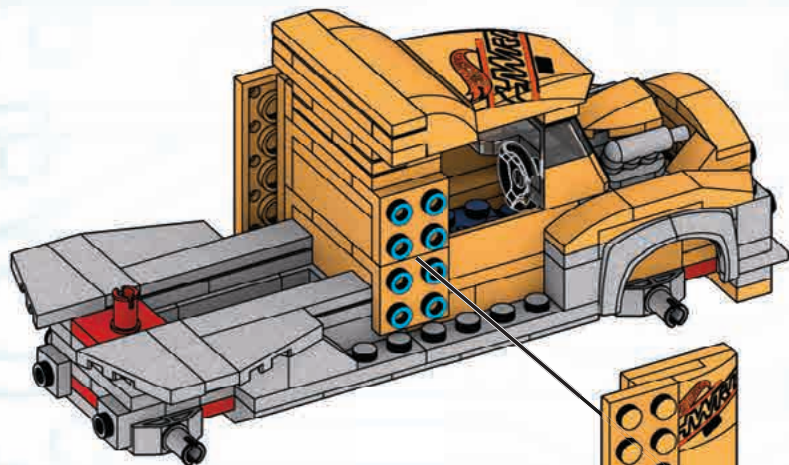

85



1x



1x

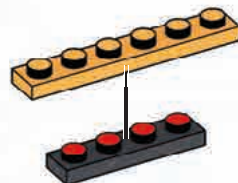

86



2x

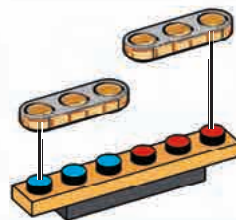

1

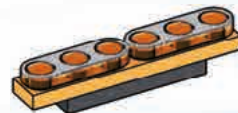

2

87

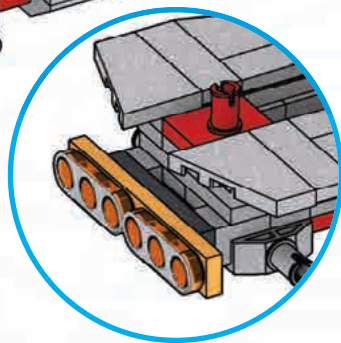
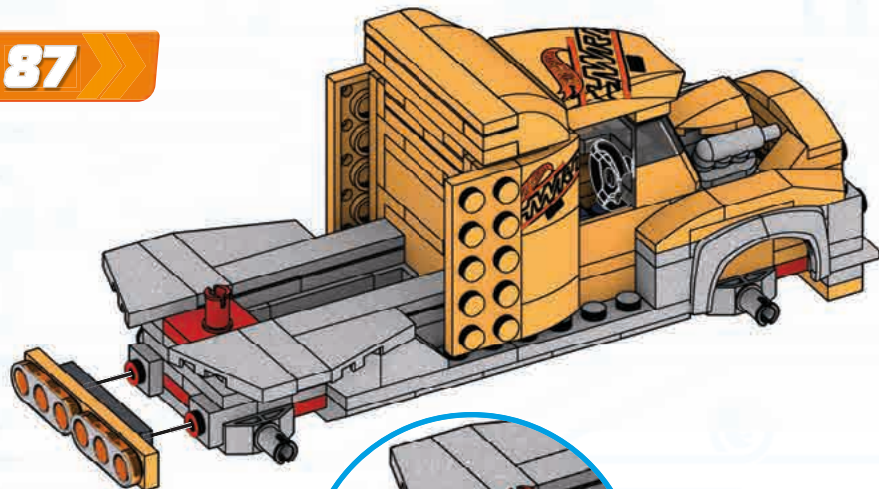

88

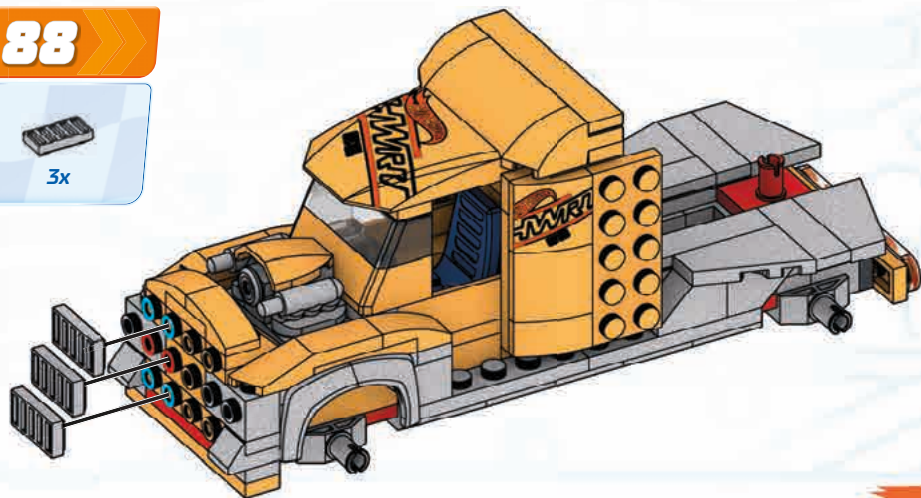



HAULER • TRANSPORTEUR

REMOLQUE • REBOQUE

89



3x

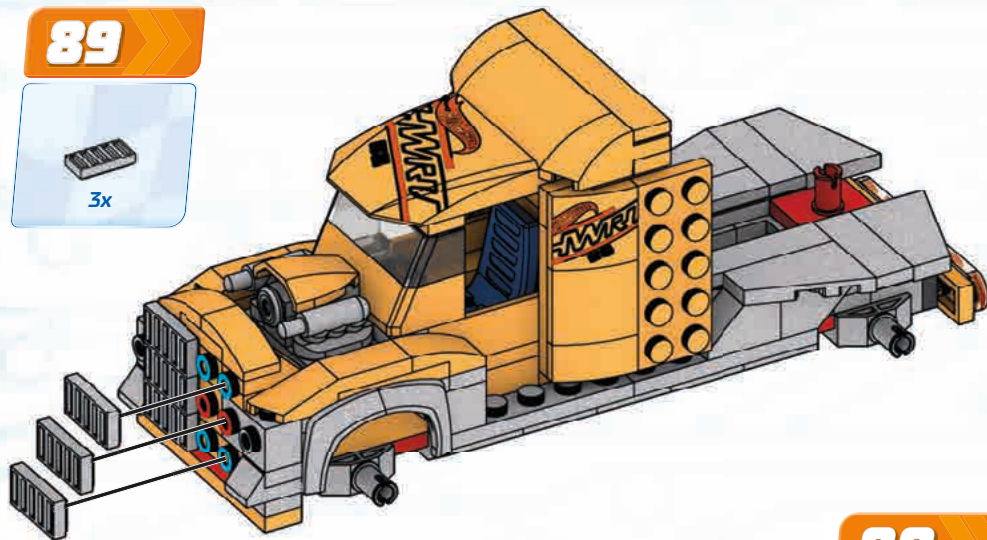

90



2x

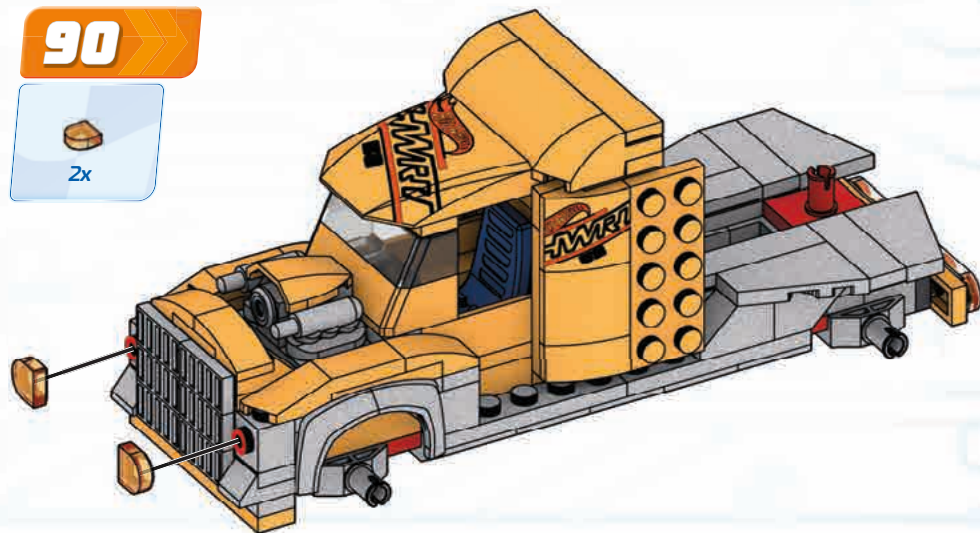

91



4x

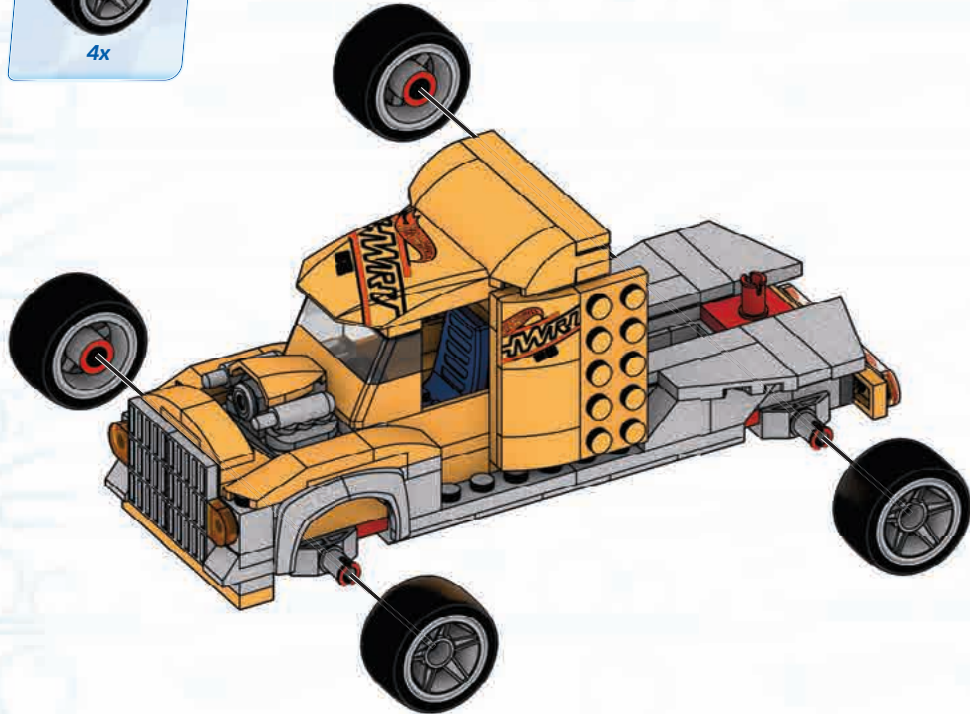

92



2x

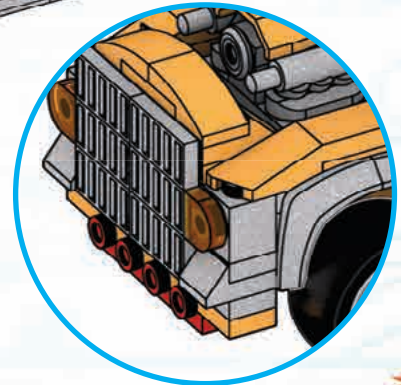
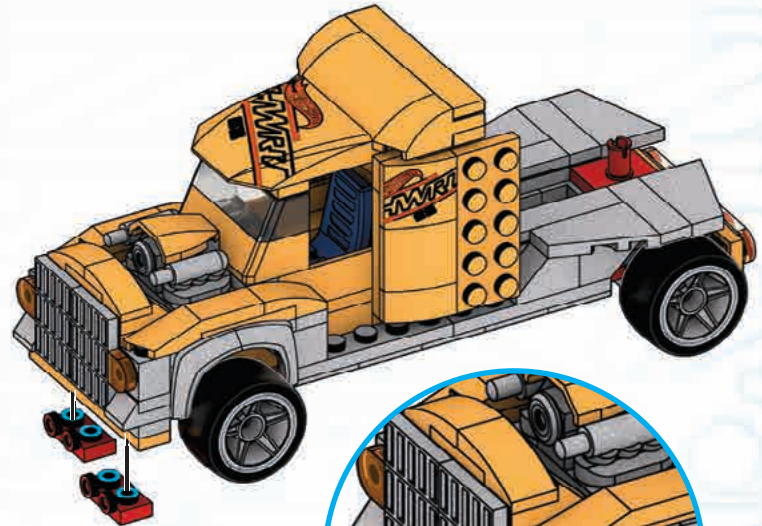



HAULER - TRANSPORTEUR

REMOLQUE - REBOQUE

93



1x

1x



94



2x

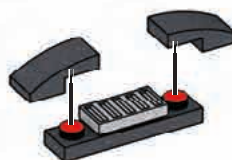

1



2

95

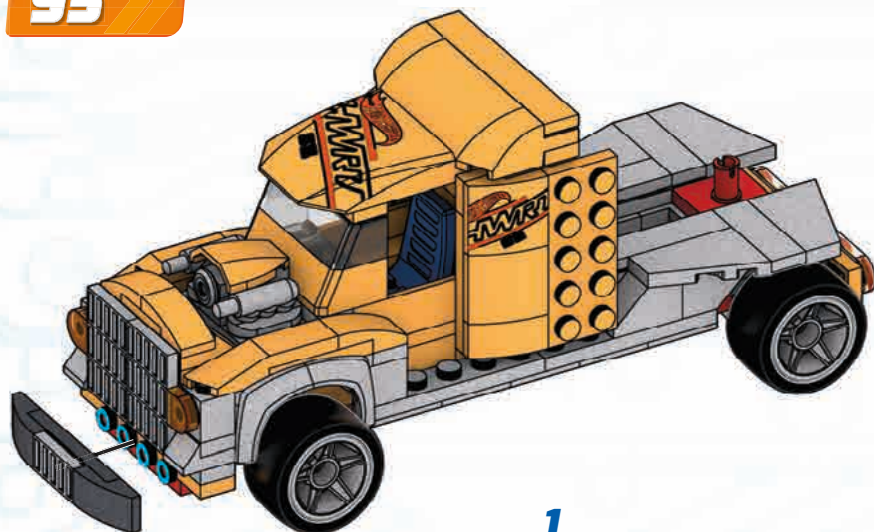

1

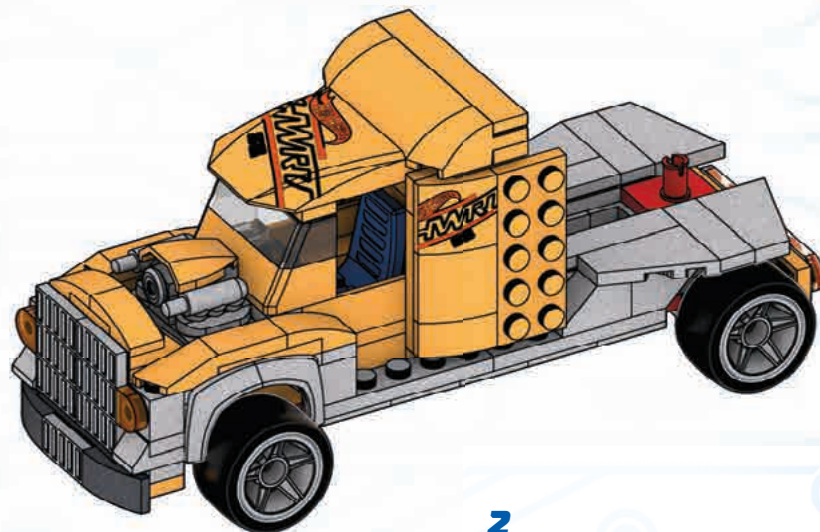

2

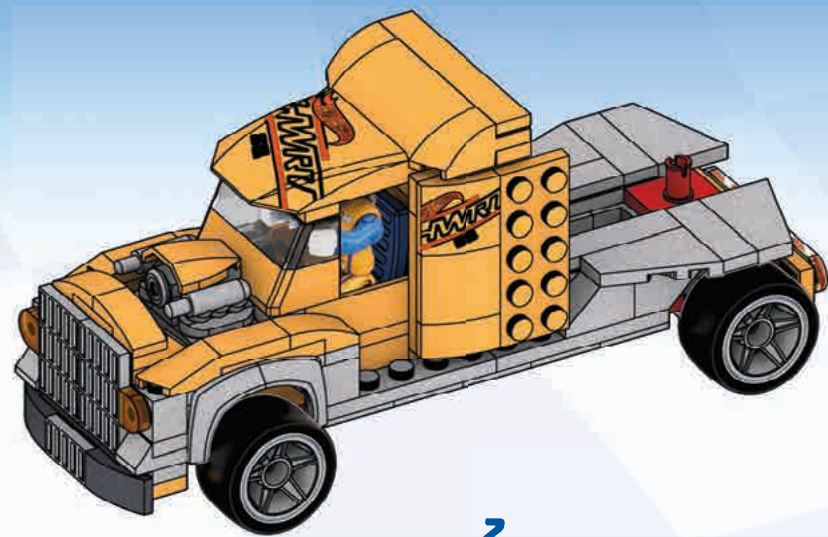
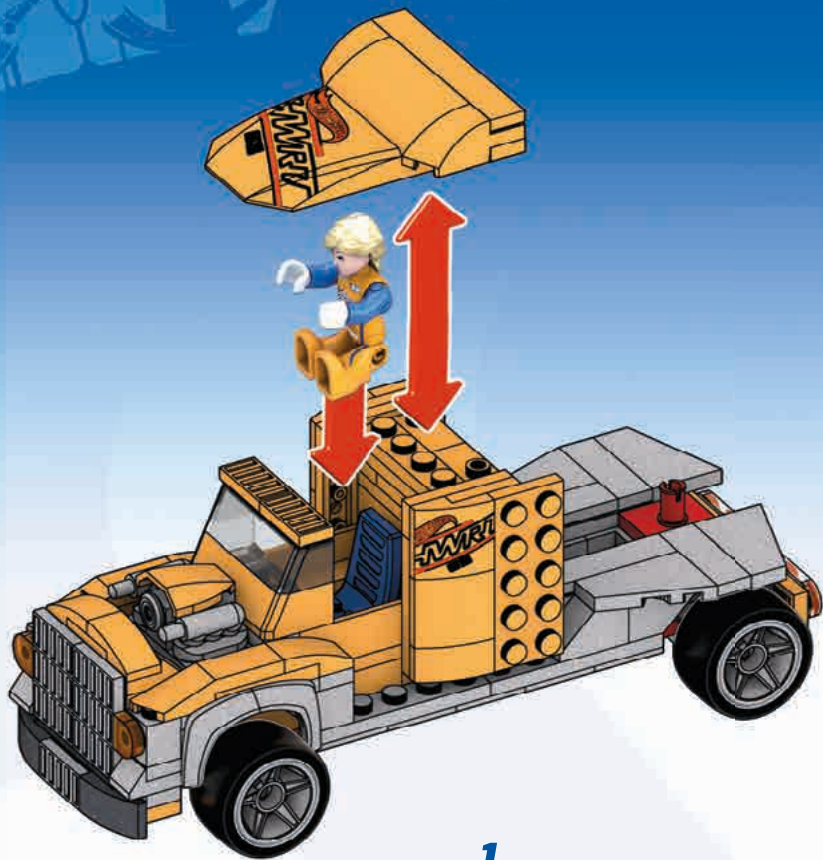



96

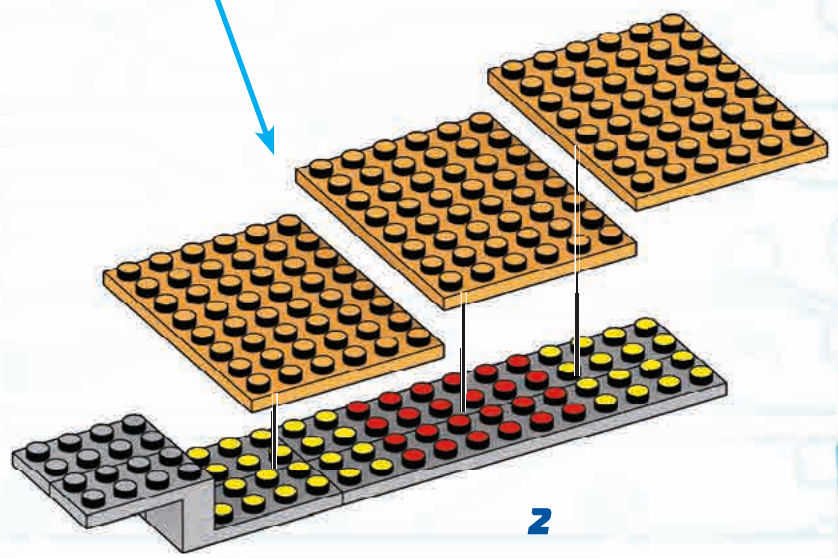
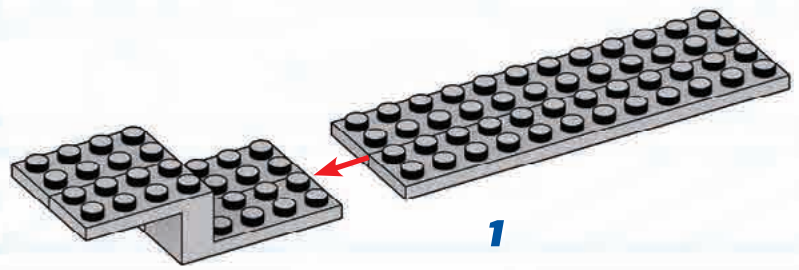
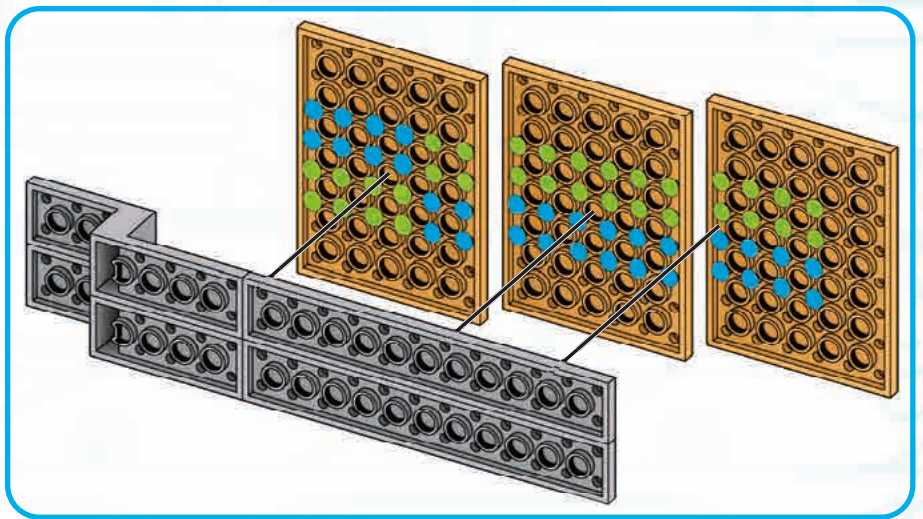
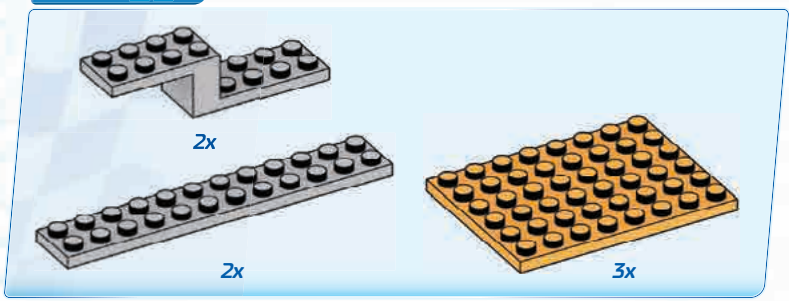

97



1x

98



2x

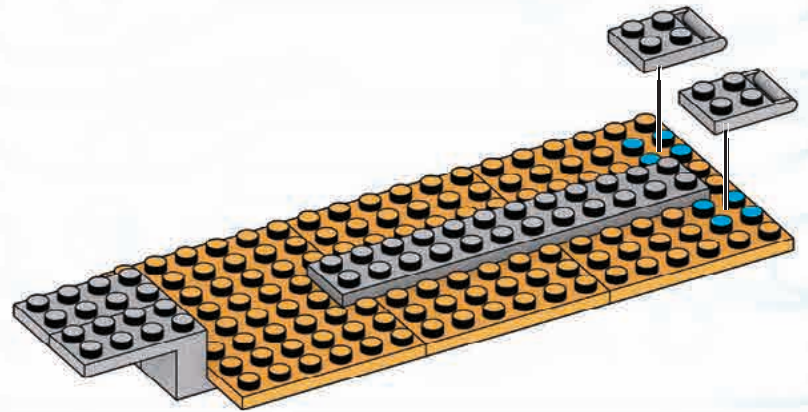
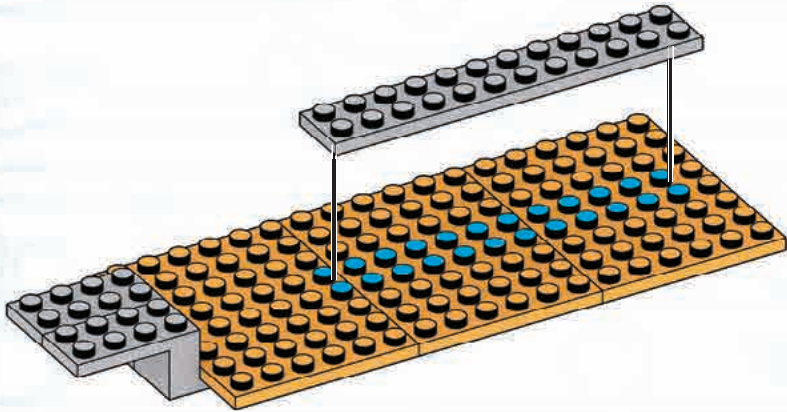



99



2x

100



1x



1x

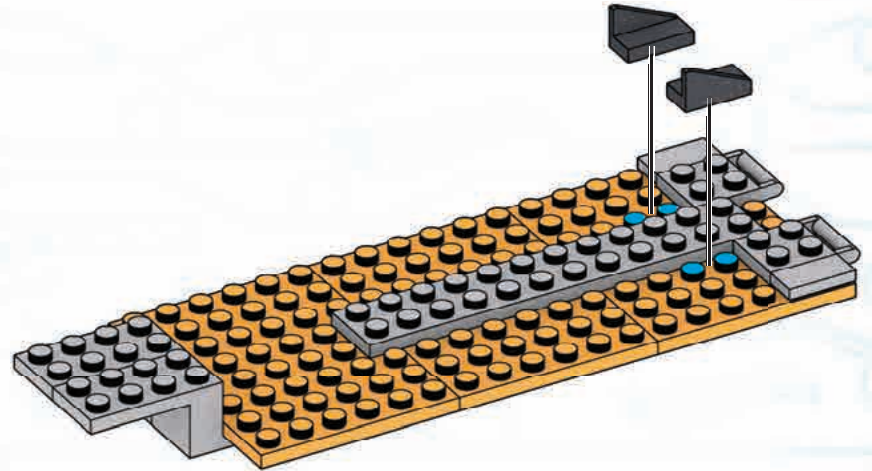
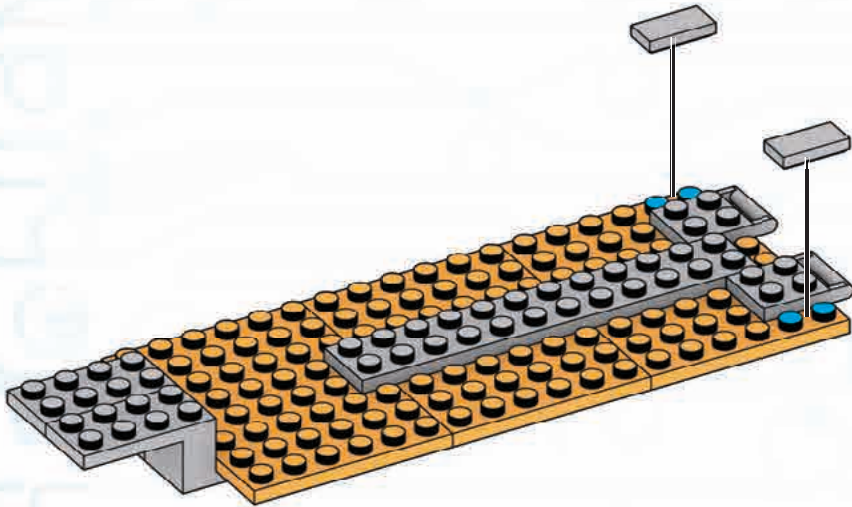

101



4x

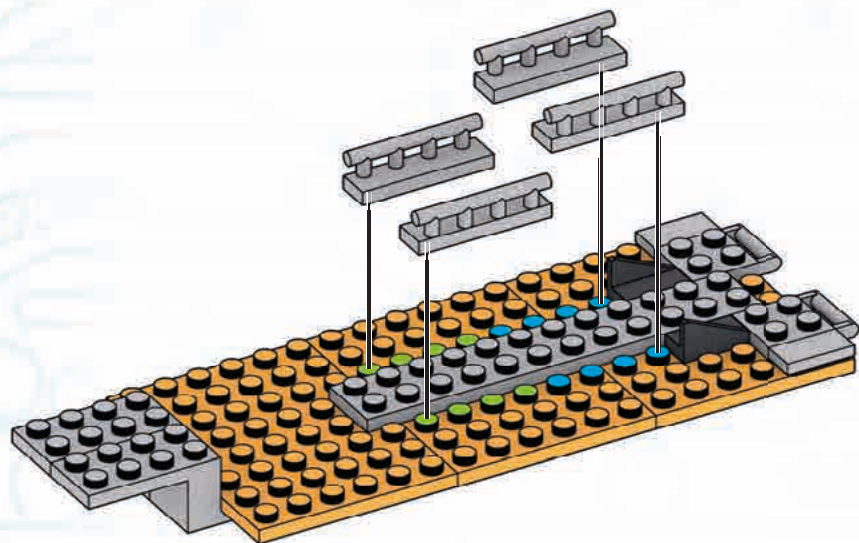

102



2x

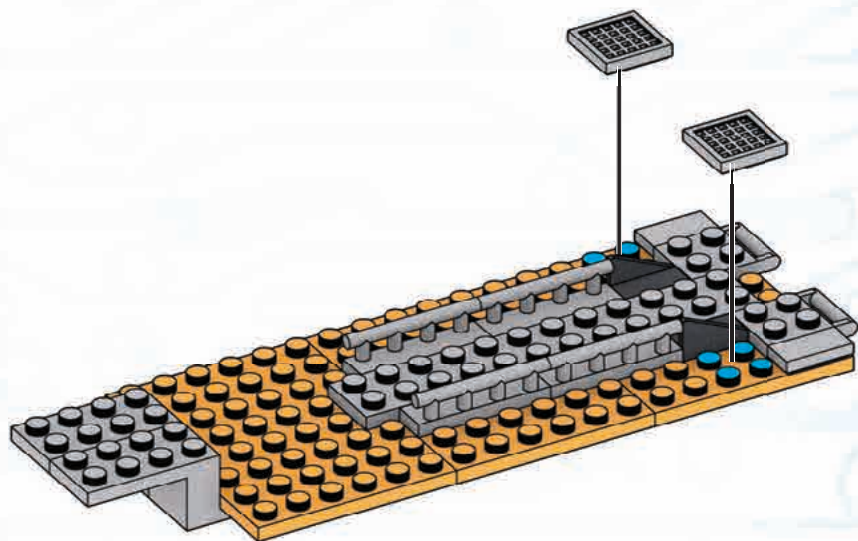



103



4x

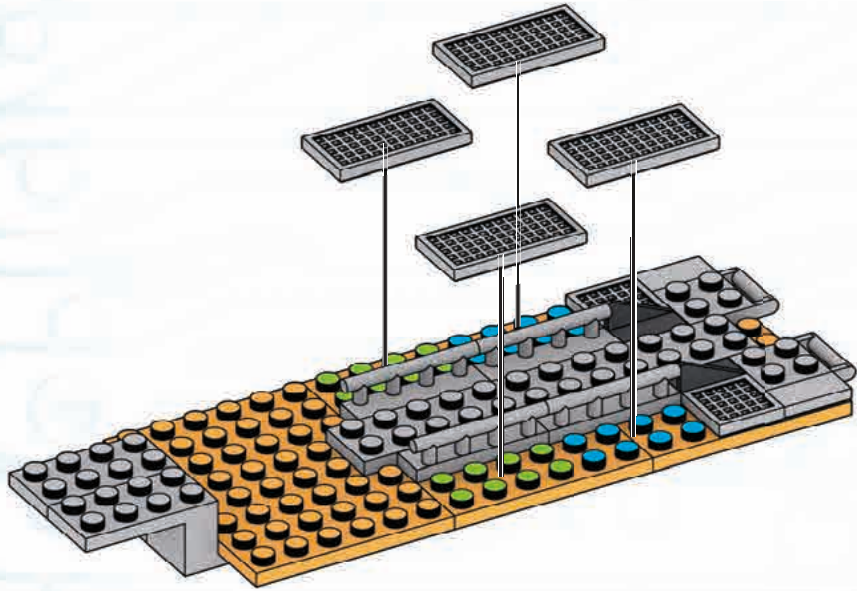

104



4x

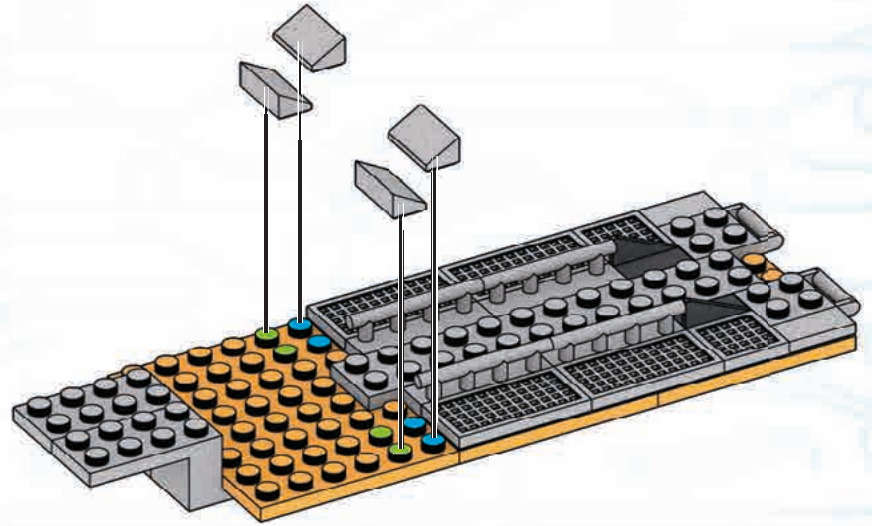

105



1x

1x

1x

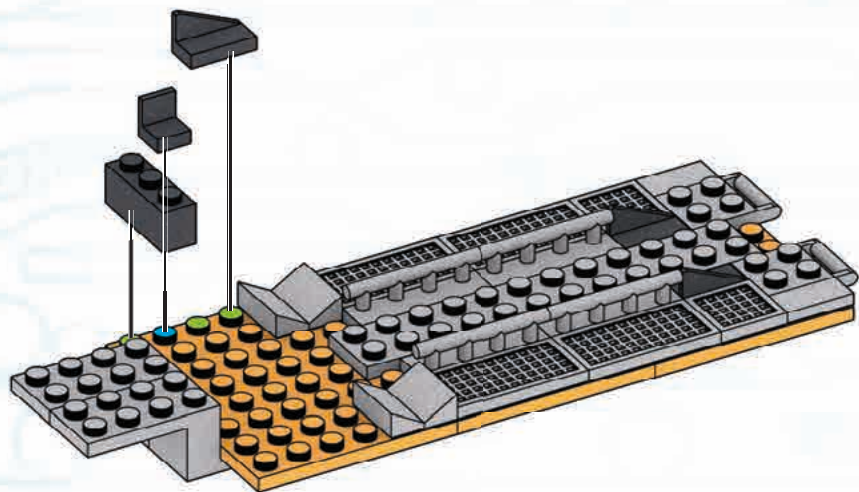

106



1x

1x

1x

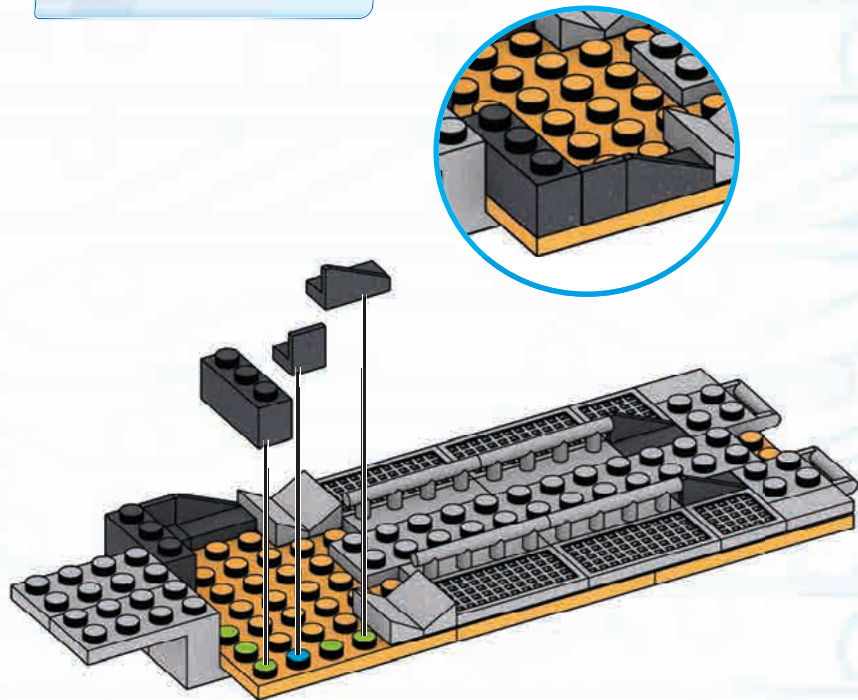



107



1x

1x

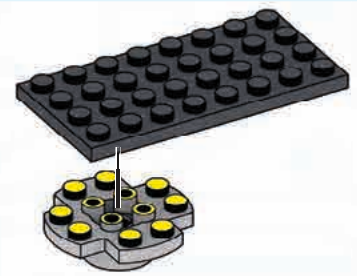

108

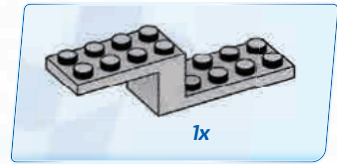

1x

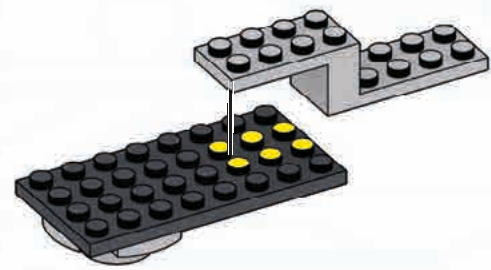

109



1x

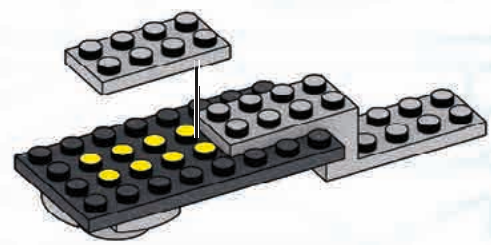

110



2x

1x

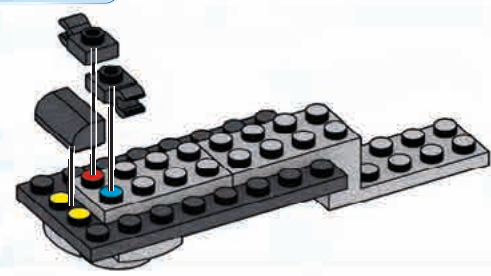

111



2x

1x

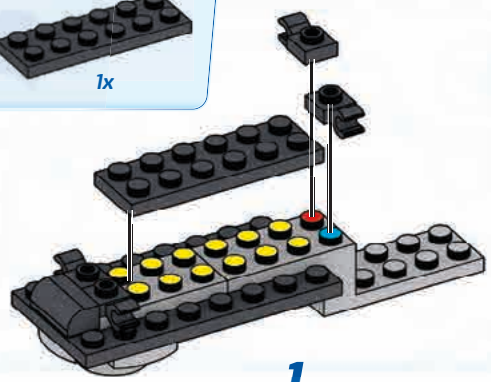

1

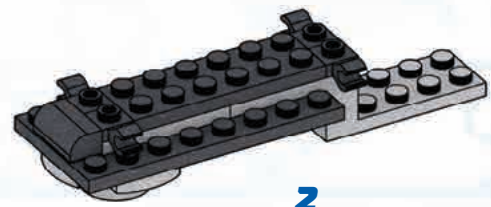

2

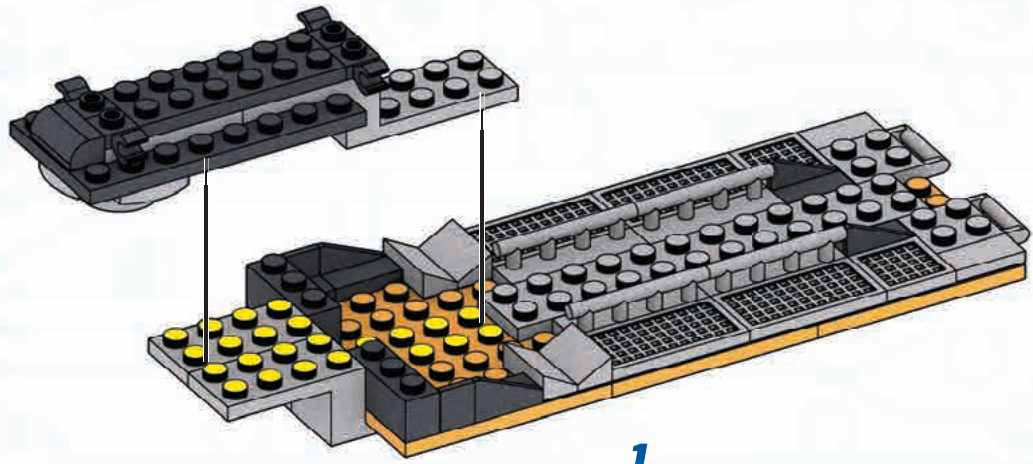

1

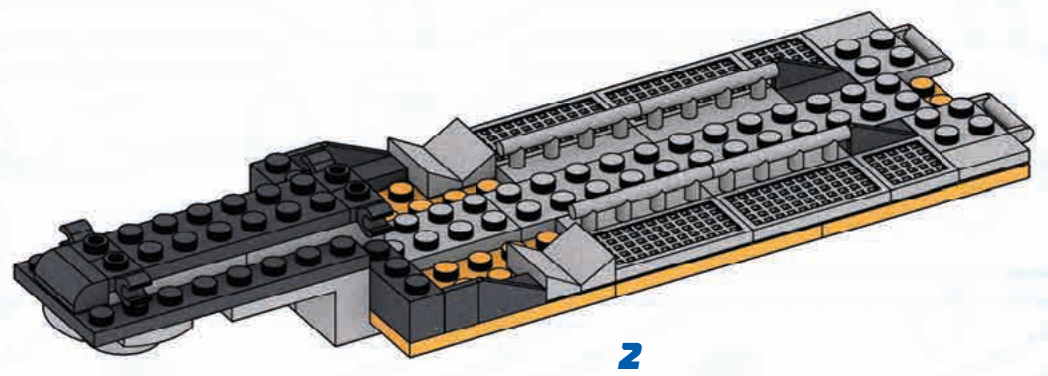

2



115

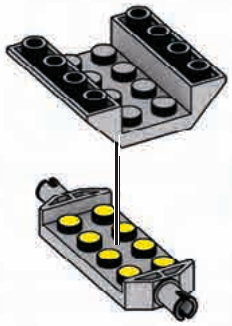
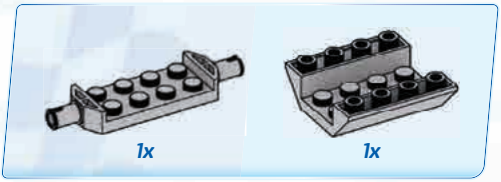

116

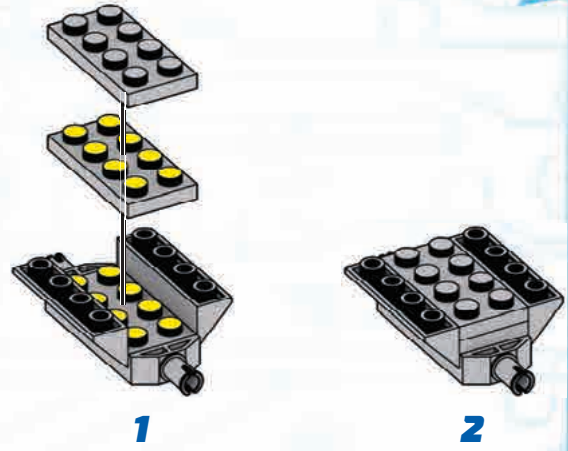

117

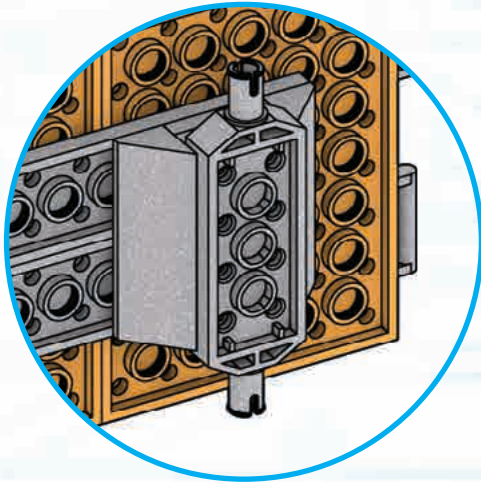
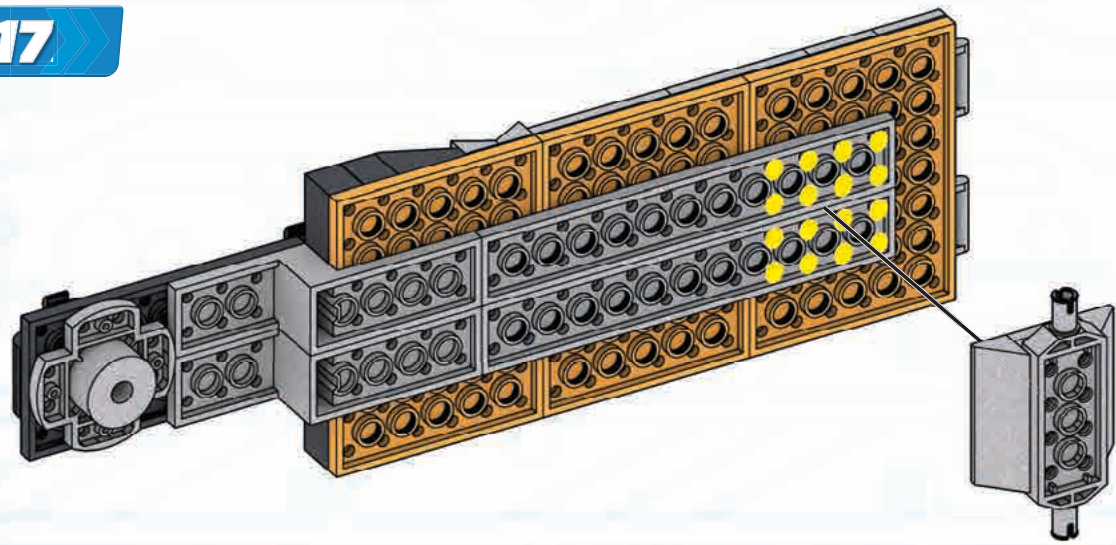

118



1x



1x

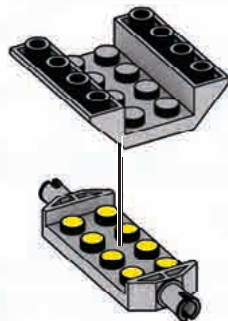

119



2x

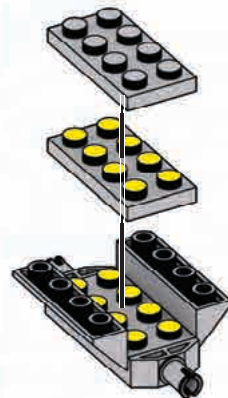

1

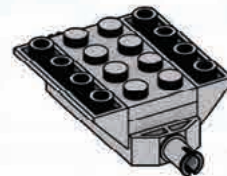

2

120

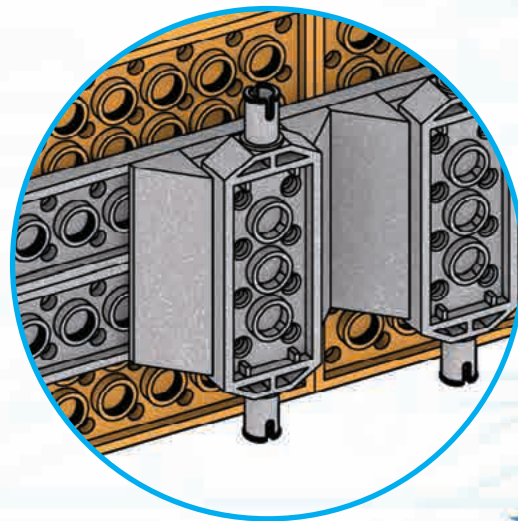
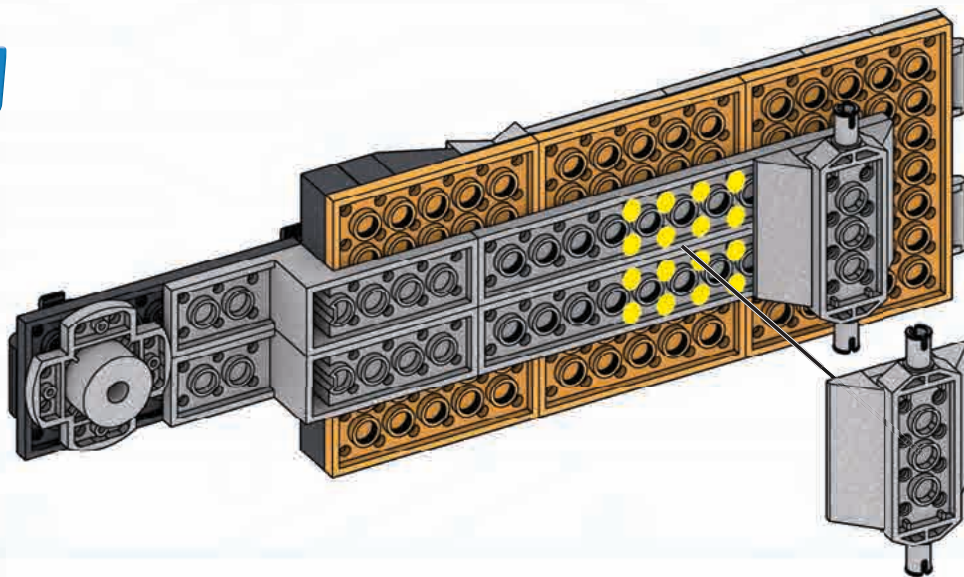



121



4x

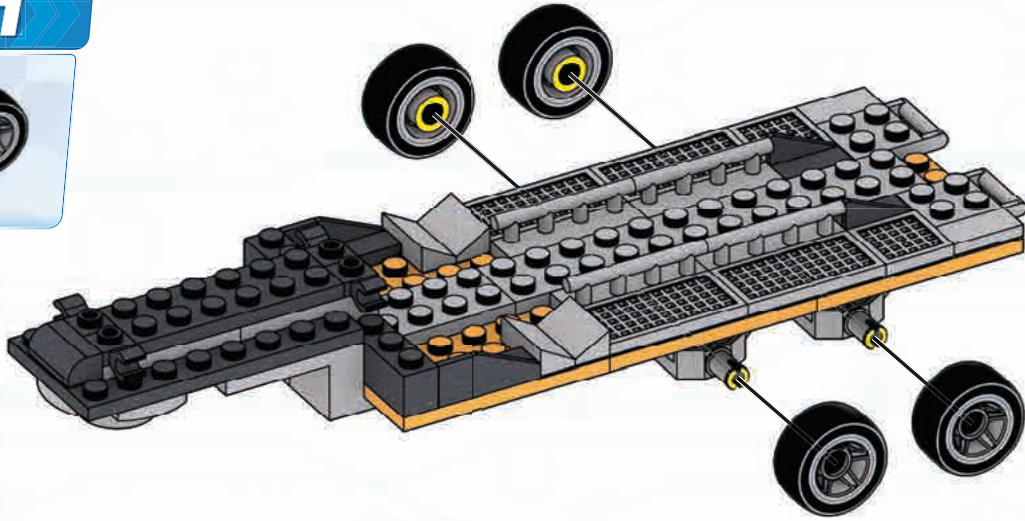

122

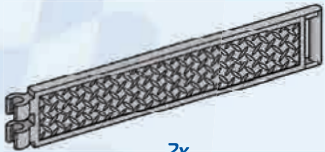

2x

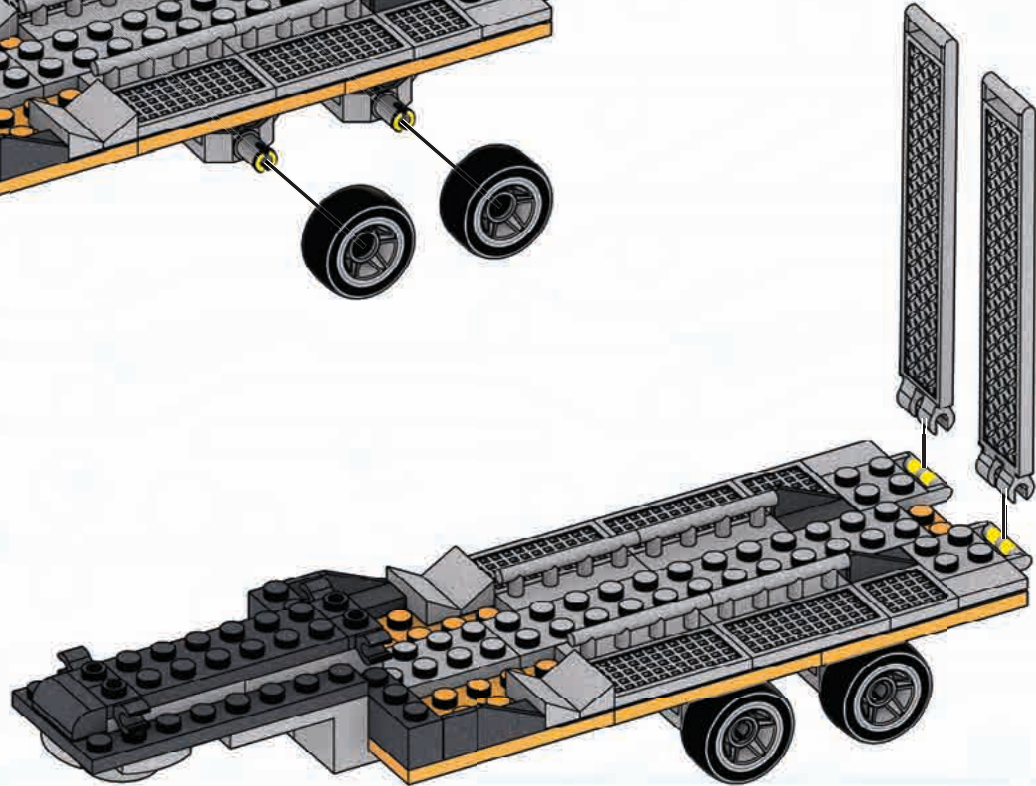

123

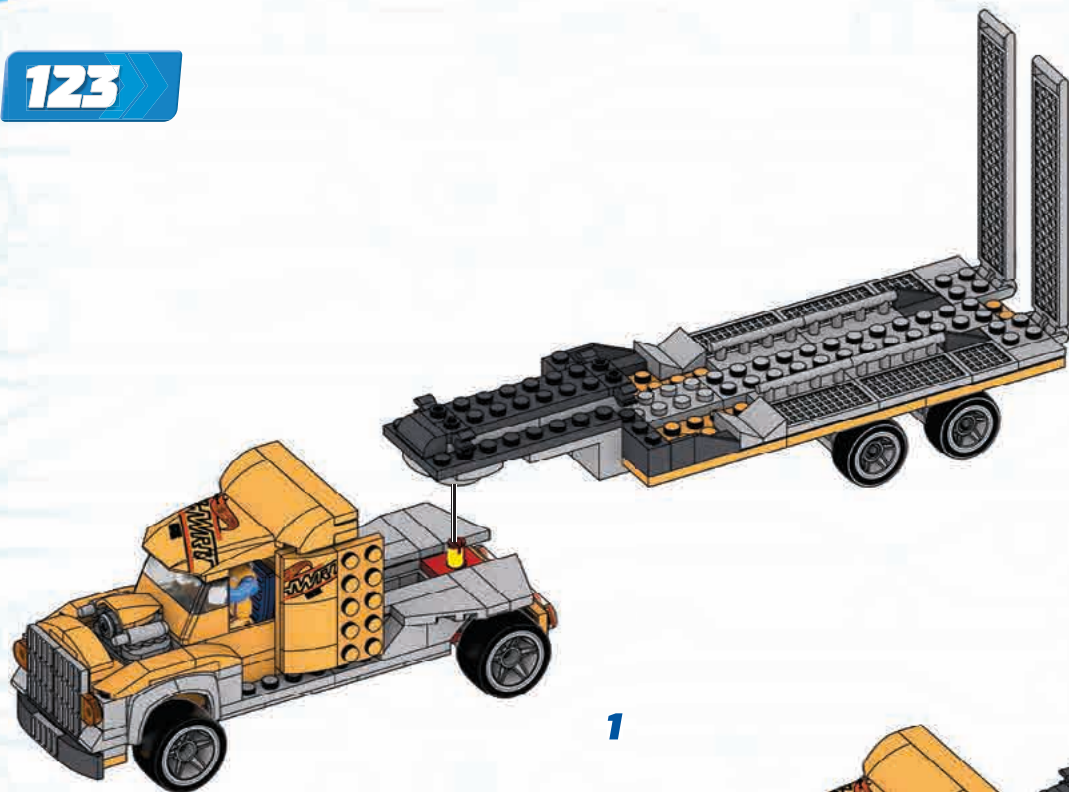

1

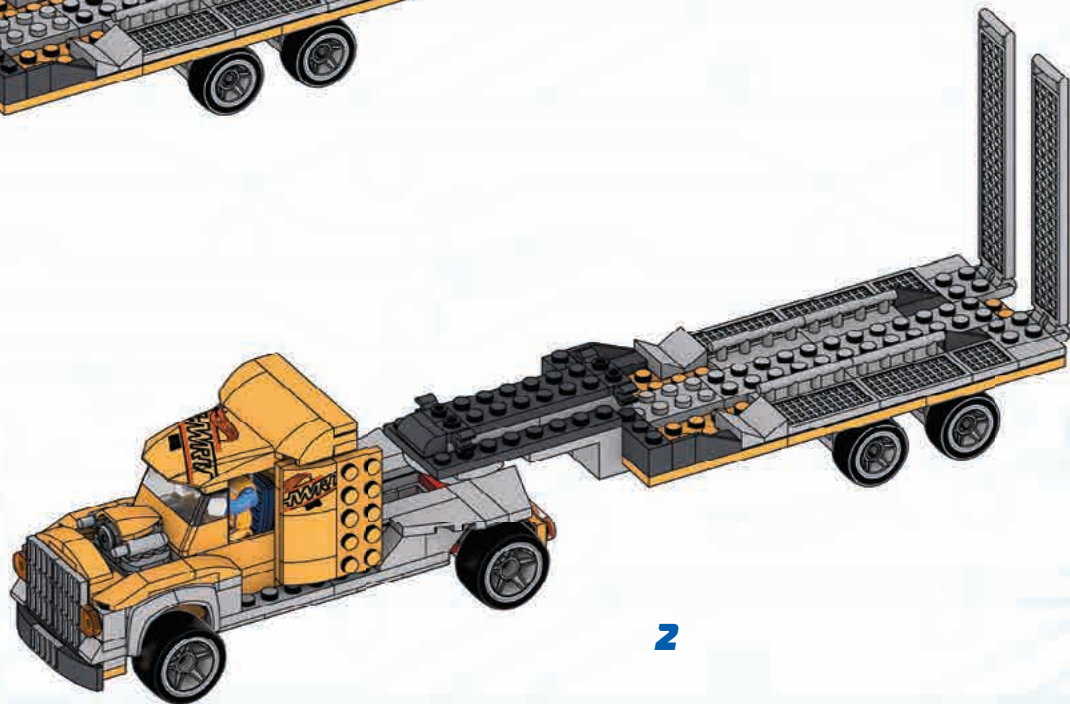

2

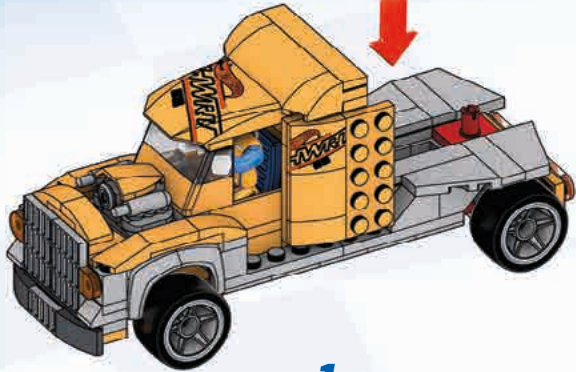
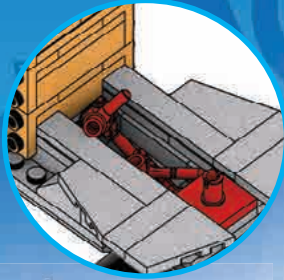
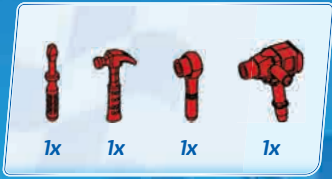

1

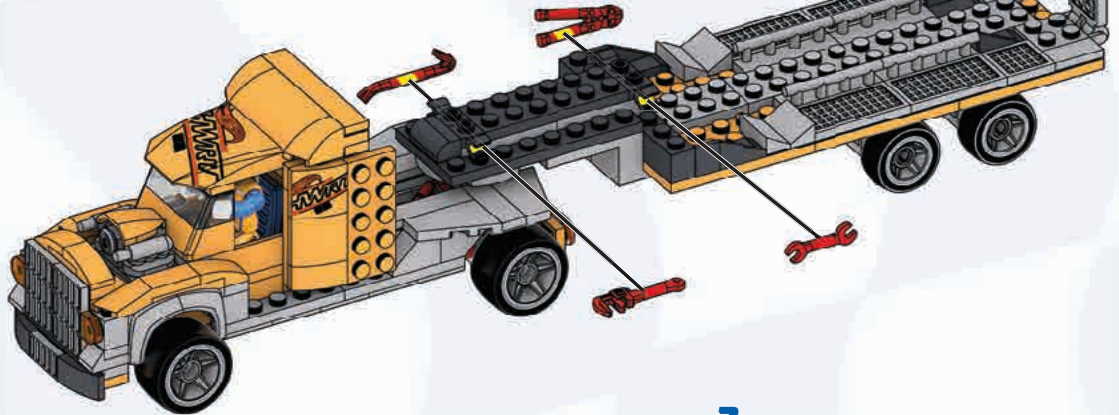
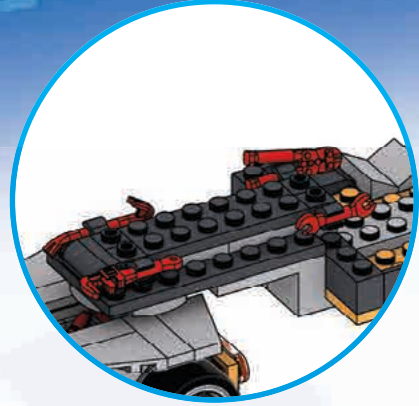

2

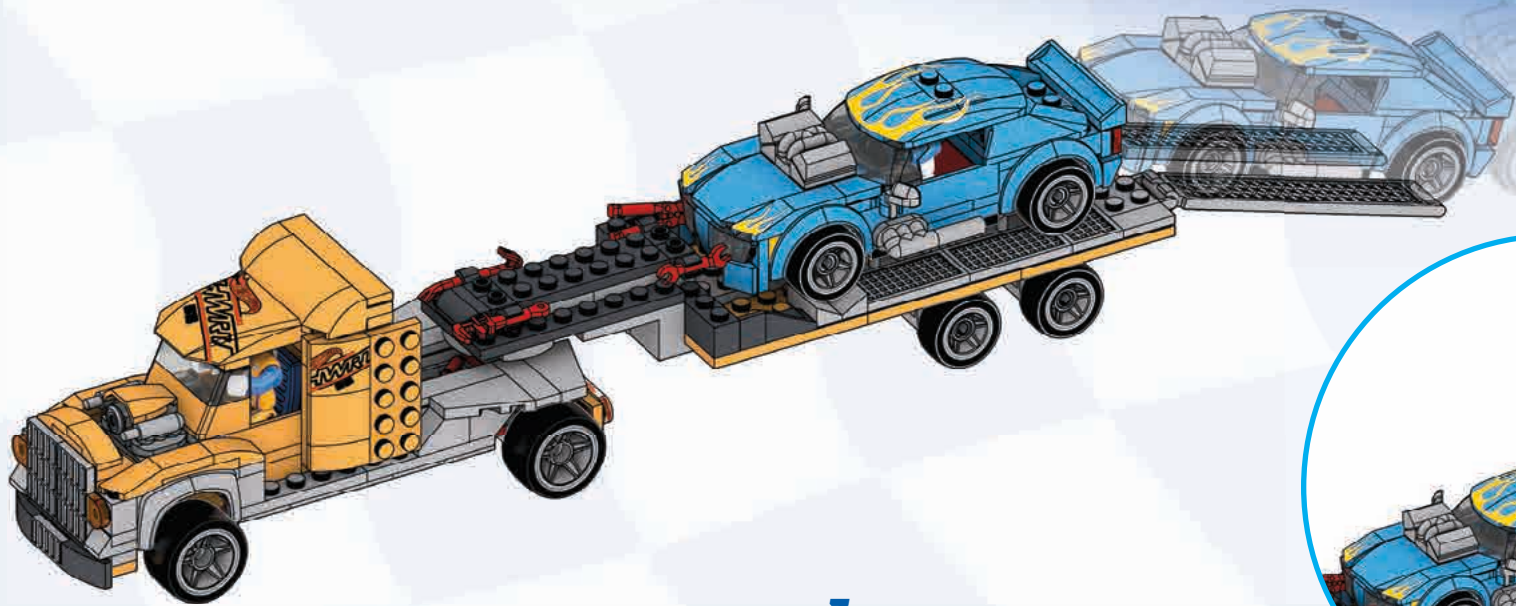

3



1x AM77341APG
 2x AM76204KC
 7x AM03328APG
 1x AM79590APG
 4x AM76959APG
 2x AM15485MM
 2x AM19530APG
 2x AM04428APG
 4x AM74415MM
 1x AM18220F
 2x AM76469APG

4x AM09198FM
 7x AM09198APG
 2x AM022501APG
 2x AM73758FM
 1x AM07590APG
 3x AM09393APG
 2x AM09393FM
 1x AM18221APG
 4x AM79070FM
 2x AM79070AMC
 2x AM81020APG

4x AM18549APG
 1x AM03017MM
 6x AM78486FM
 2x AM78486MM
 2x AM81255MM
 2x AM81256MM
 2x AM18740FM
 2x AM17522APG
 2x AM01322APG
 4x AM01417APG

1x AM09013FM
 1x AM17502FM
 2x AM17502APG
 1x AM81021FM
 2x AM15484APG
 2x AM18525APG
 1x AM03773APG
 2x AM03773FM
 12x AM18223APG

1x AS-GYG66-07
 1x AS-GYG66-06
 2x AM74106FM
 1x AM76379AMC
 4x AM09106FM
 4x AS-GYG66-01
 2x AM18329APG
 2x AS-GYG66-04
 2x AM80966APG

4x AM01314FM
 2x AM01314APG
 2x AM16384MM
 2x AM80967APG
 2x AM19899APG
 2x AM19898APG
 1x AM03772APG
 1x AM80541B
 1x AM80982FM
 1x AM80981FM

10x AM09593FM
 3x AM09593MM
 2x AM09593APG
 4x AM01847APG
 2x AM17521FM
 1x AM01087FM
 2x AM80973APG
 4x AS-GYG66-02
 1x AM80921APG

4x AM18276APG
 1x AM18299APG
 6x AM09493APG
 3x AM09493FM
 3x AM09033FM
 1x AS-GYG66-03
 2x AM17793APG
 4x AM07475APG

2x AM80737APG
 4x AM80965FM
 4x AM81091APG
 1x AM16331FM
 3x AM09292FM
 1x AM09292APG
 2x AM01313APG
 2x AM01313FM



1x
AM19011FM



1x
AM01480MM



1x
AM04983B



3x
AM17055AMC



1x
AM17845MM



1x
AS-GYG66-05



3x
AM81261APG

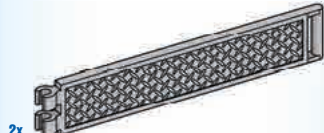

2x
AM81258APG

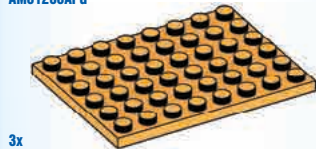

3x
AM74678FM



4x
AM01172APG



1x
FIG-GYG66-A



1x
AM15017AMC



1x
AM15018AMC



1x
AM15019AMC



1x
AM15020AMC



1x
AM15021AMC



1x
AM15022AMC



1x
AM15023AMC



1x
AM15024AMC



Missing pieces?
Pièces manquantes?
¿Partes faltantes? • Perdeu peças?
Fehlende Teile? • Не хватает деталей?

support.megabrands.com

CAMION TRASPORTATORE CON AUTO TWINDUCTION / TWINDUCTION TRANSPORTER PACK / TRANSPORTER TWINDUCTION ZESTAW TWINDUCTION TRUCK PACK / НАБОР ПЕРЕВОЗЧИКОВ TWINDUCTION™ / TWINDUCTION™ ΝΤΑΛΙΚΑ / TWINDUCTION KAMYON PAKETI™ TWINDUCTION VEYNTATÖ CSOMAG / مجموعة TWINDUCTION HAULER PACK

Mattel Europa B.V., Gondel 1, 1186 MJ Amstelveen, Nederland. Mattel U.K. Limited, The Porter Building, 1 Brunel Way, Slough SL1 1FQ, UK. Mattel France, Parc de la Ceisaie, 1/3/5 allée des Fleurs, 94260 Fresnes Cedex. N° Cristal 0969 36 99 99 (Numéro non surtaxé) ou www.lesjouetsmattel.fr Mattel Belgium, Trade Mart, Atomiumsquare, Bogota 202 – B 275, 1020 Brussels. Gratis nummer België: 0800 – 16 936 - Gratis nummer Luxemburg: 800 - 22 784 - Gratis nummer Nederland: 0800 - 262 88 25. Deutschland: Mattel GmbH, Solmsstraße 4, D-60486 Frankfurt am Main. Schweiz: Mattel AG, Kirchstrasse 24, CH-3097 Liebefeld. Österreich: Mattel Ges.m.b.H., Campus 21, Liebermanstraße A01 404, A- 2345 Brunn/Geirige. Mattel Italy Srl, Via Bracco, 6-MAC 6, 20159 Milano, Italy. Servizio assistenza clienti: Customersrv.it@mattel.com - Numero verde 800 11 37 11. Mattel España, S.A., Arbuja 200, 08036 Barcelona. cservice.spain@mattel.com.Tel: 902203010 http://www.service.mattel.com/es. Mattel East Asia Ltd., Room 503-09, North Tower, World Finance Centre, Harbour City, Tsimshatsui, HK, China. Tel.: (852) 3185-6500. Diimport: Diederik Olieh: Mattel Continental Asia Sdn Bhd. Level 19, Tower 3, Avenue 7, No. 8 Jalan Kerinci, Bangsar South, 59200 Kuala Lumpur, Malaysia. Mattel South Africa (PTY) LTD, Office 102 13, 30 Melrose Boulevard, Johannesburg 2196. Dystrybutor: Mattel Poland Sp. z o.o., Warsaw Trade Tower 34 p., ul. Chłodna 5, 00-867 Warszawa. Mattel Australia Pty. Ltd., 658 Church St., Richmond, Victoria, 3121. Consumer Advisory Service - 1300 135 312. Mattel AEBE, Εθνάρχου Μακαρίου 1, Κτήριο Κ-2, ΤΚ 17561, Παλαιό Φάληρο. Mattel Oyuncakçılık Tic. Ltd. Şti. İçerenköy Mah., Erkut Sok. A Blok No:12 Üner Plaza Kat:9-10 34752 Ataşehir İstanbul. Tel: 0216 570 75 00. Импортер/Уполномоченная организация: ООО "МАТЕЛ" Российская Федерация, 105120 Москва, 2-й Сыромятинский переулок, 1; +7 495 287 79 39. Forg.: Mattel Toys Hungary Kft 1139 Budapest Váci út 91. +36 1 270 0223. Mattel Czech Republic s.r.o., The Forum, Václavské nám. 19, 11000 Praha 1. Mattel, 333 Continental Boulevard, El Segundo, CA 90245, USA. Consumer Services: 1-800-465-MEGA (6342). Importado y distribuido por Mattel de México, S.A. de C.V., Miguel de Cervantes Saavedra No. 193, Pisos 10 y 11, Col. Granada, Alcaldía Miguel Hidalgo, C.P. 11520, México, Ciudad de México. R.F.C. MME-920701-NB3. Tels: 59-05-51-00 Ext. 5206 ó 01-800-463-59-89. Mattel Chile, S.A., Avenida América Vespucio 501-B, Quilicura, Santiago. Tel: 1230-020-6213. Servicio al consumidor Venezuela: Tel: 0-800-100-9123. Mattel Argentina, S.A., Av. Libertador 1000, Piso 11 – Oficinas 109 y 111, Vicente López – Prov. Buenos Aires. Tel: 0800-666-3373. Mattel Colombia, S.A., Calle 123#07 P5, Bogotá. Tel: 01800-710-2069. Mattel Perú, S.A., Av. Juan de Arona # 151, Centro Empresarial Juan de Arona, Torre C, Piso 7, Oficina 704, San Isidro, Lima 27, Perú. RUC: 20425853865. Reg. Importador: 02350-12-UE-DIGESA. Tel: 0800-54744. E-mail Latinoamérica: servicio.clientes@mattel.com. Mattel do Brasil Ltda. - CNPJ : 54.558.002/0001-20 - Rua Verbo Divino, 1488 - 2º. Andar - 04719-904 - Chácara Santo Antônio - São Paulo - SP - Brasil. Serviço de Atendimento ao Consumidor: fone 0800 575 0780. E-mail: sac.matteldobrazil@mattel.com

⚠ WARNING:
CHOKING HAZARD. - Small parts.
Not for children under 3 years.

⚠ ATTENTION:
DANGER D'ÉTOUFFEMENT. - Présence de petits éléments.
Ne convient pas aux enfants de moins de 3 ans.

⚠ 警告:
のどに つまる危険 小さな部品が含まれています
3歳以下の子供には与えないで下さい。

⚠ تحذير:
غير مناسبة للأطفال دون 36 شهرأ - قطع صغيرة.

⚠ 警告!
不适合3岁以下儿童使用。
内含小零件。

ADVERTENCIA: PELIGRO DE ATRAGANTAMIENTO. Juguete no recomendado para menores de 3 años, porque contiene piezas pequeñas que podrían provocar asfixia en caso de ser ingeridas o inhaladas por el/la niño/a.

ATENÇÃO! Não indicado / não recomendável para crianças menores de 3 (três) anos por conter parte(s) pequena(s) que pode(m) ser engolid(a)s ou aspirada(s) podendo provocar asfixia.

AVVERTENZA: Contiene pezzi di piccole dimensioni.

ACHTUNG: Kleine Teile.

OSTRZEŻENIE: Małe części. Niebezpieczeństwo zadławienia.

WAARSCHUWING: Kleine onderdelen

ADVARSSEL: Indeholder små dele.

WARNING: Små delar

ADVARSSEL: Små deler

VAROITUS: Pieniä osia

ΠΡΟΣΟΧΗ: Περιλαμβάνονται μικρά κομμάτια.

UYARI: Küçük parçalar.

UPOZORNENIE: Malé diely

UPOZORNENIE: Malé časti

FIGYELMEZTETÉS: Kis alkatrészek.



MEGA
CONSTRUX™

HOT WHEELS™

TWINDUCTION HAULER PACK™
COFFRET TRANSPORTEUR TWINDUCTION
SET REMOLQUE TWINDUCTION
CONJUNTO REBOQUE TWINDUCTION



10+
PRO
BUILDERS™

**Are you ready for
the next challenge?**
**Prêt pour le
prochain défi ?**

¿Estás listo para el siguiente desafío?
Você está pronto para o próximo desafio?
Bist du bereit für die
nächste Herausforderung?
Вы готовы к следующему испытанию?



MORE TO BUILD! ENCORE PLUS À CONSTRUIRE!
¡MÁS PARA CONSTRUIR! - MAIS PARA CONSTRUIR!
MEHR ZUM BAUEN! - КОНСТРУИРУЙ БОЛЬШЕ!



GVM27



GYG36



GYG34



GYG32



GYG37



GYG35



GYG33



GVM26



Set(s) sold separately and subject to availability. / Ensemble(s) vendu(s) séparément. Certains produits peuvent ne pas être commercialisés. / Se vende(n) por separado y está(n) sujeto(s) a disponibilidad. / Conjunto(s) vendido(s) em separado e sujeito(s) à disponibilidade. / Set in vendita separatamente, secondo disponibilità. / Das/Die Set(s) sind separat erhältlich. / Zestaw(y) sprzedawany(e) oddzielnie w zależności od dostępności. / Set(s) apart verkrijgbaar en afhankelijk van beschikbaarheid. / Набор(-ы) продается отдельно, при наличии. / Sæt sælges separat og så længe lager haves. / Seten säljs separat så länge lagret räcker. / Settet/settene selges separat så langt lageret rekker. / Pakkaus/pakkaukset myydään erikseen, saatavuus voi vaihdella. / Το(α) σετ πωλούνται ξεχωριστά και ανάλογα με τη διαθεσιμότητα. / Setler ayrı olarak satılır ve stoklara sınırlıdır. / Set (sety) se prodává (prodávají) samostatně dle aktuální nabídky. / Súprava/-y sa predáva(jú) samostatne a podľa dostupnosti. / A készlet(ek) külön kapható(k), az elérhetőség változhat. /

セット商品は別売りになります。在庫状況は別途ご確認をお願いします。 /

تباع المجموعة أو المجموعات على حدة وتخضع لتوافرها.

每套单独发售，按供货情况决定。

© 2020, MEGA Brands &™ MEGA Brands; CONSTRUX™, HOT WHEELS and associated trademarks and trade dress are owned by and used under license from Mattel. CONSTRUX™, HOT WHEELS ainsi que les marques et designs y afférents appartiennent à, et sont utilisés sous licence de Mattel. © 2020 Mattel. 1186 MJ, 1, NL Printed in China / Imprimé en Chine AD-GYG66-02



Mattel Canada Inc. Mississauga, Ontario L5R 3W2.
MADE IN CHINA. FABRIQUÉ EN CHINE. / FABRICADO NA / HECHO EN CHINA.
ИЗГОТОВЛЕНО В КИТАЕ. ÇIN'DE ÜRETİLMİŞTİR. صنع في الصين