



# Barbie

# Color Reveal



HHW83

DOLPHIN EXPLORATION

NAGE AVEC LES DAUPHINS

EXPLORACIÓN CON DELFINES / EXPLORAÇÃO COM GOLFINHOS



## Build Construisez

Construye | Constrói  
Bauen | Стройте



## Share | Partagez

Comparte | Partilha  
Teilen | Делитесь

Devices not included | Appareils non inclus | Dispositivos no incluido  
Dispositivos não incluídos | Geräte nicht enthalten | Устройства не входят в комплект



## Play as you build! Jouez en construisant!

Juega mientras construyes!  
Construção e brincadeira simultâneas!  
Gleichzeitig bauen und spielen!  
Строй и играй!



megaunboxed.com

# CHOOSE WHAT YOU WANT TO BUILD FIRST! CHOISISSEZ CE QUE VOUS VOULEZ CONSTRUIRE EN PREMIER!

İELIGE QUÉ QUIERES CONSTRUIR PRIMERO! • ESCOLHA O QUE VOCÊ QUER CONSTRUIR PRIMEIRO! KINDER  
KÖNNEN AUSSUCHEN, WAS SIE ZUERST BAUEN WOLLEN! • ВЫБЕРИ, ЧТО ТЫ ХОЧЕШЬ СОБРАТЬ СНАЧАЛА!



P.4



P.18



P.36

# WHAT WILL YOU REVEAL? QU'ALLEZ-VOUS DÉCOUVRIR?

¿QUÉ VAS A REVELAR? • O QUE VOCÊ VAI REVELAR?  
WELCHE PUPPE KOMMT ZUM VORSCHEN? • КАКУЮ КУКЛУ ВЫ ОТКРОЕТЕ?

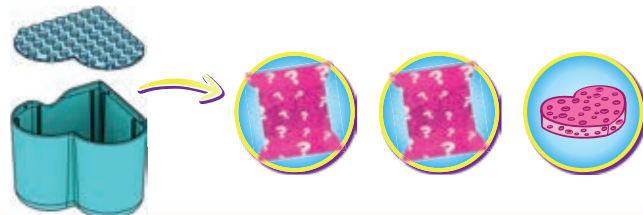



## CUSTOMIZE YOUR BARBIE® MICRO-DOLL! PERSONNALISEZ VOTRE MICRO-POUPÉE BARBIE®!

PERSONALIZA TU MICROMUÑECA BARBIE®! • PERSONALIZE A SUA MICROBONECA BARBIE®!  
DIE BARBIE MIKROPUPPE LÄSST SICH IMMER WIEDER NEU GESTALTEN! • СОЗДАЙТЕ СВОЮ МИКРОКУКЛУ BARBIE®!



1



2



1



2

# LET'S BUILD THE BOAT! CONSTRUIONS LE BATEAU!

¡CONSTRUYAMOS EL BARCO!  
VAMOS CONSTRUIR O BARCO!  
EIN BOOT BAUEN!  
ПОСТРОИМ ЛОДКУ!



1

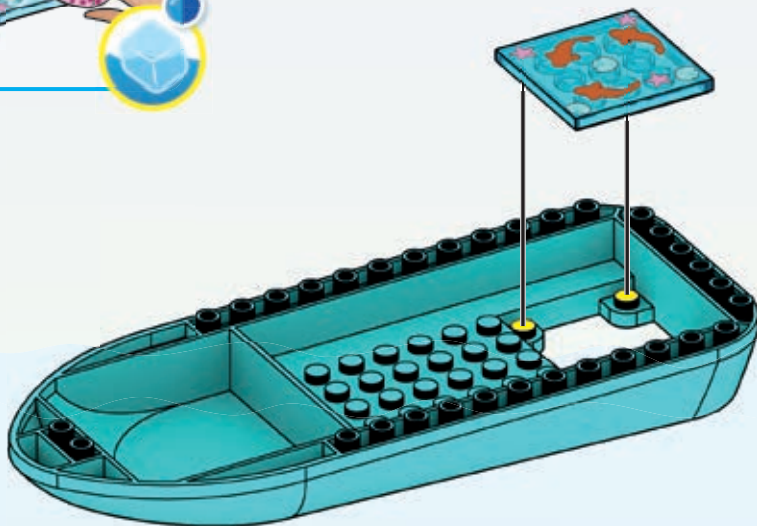
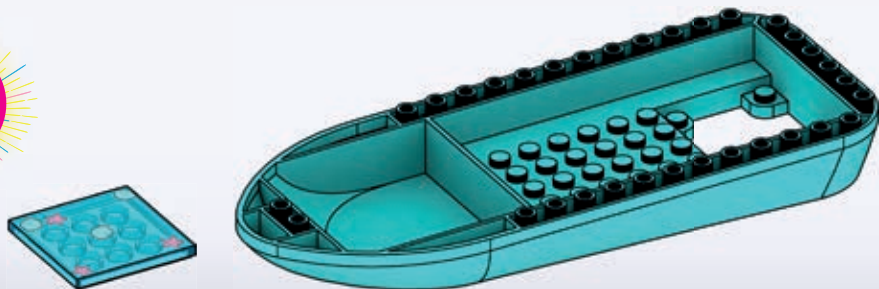

2

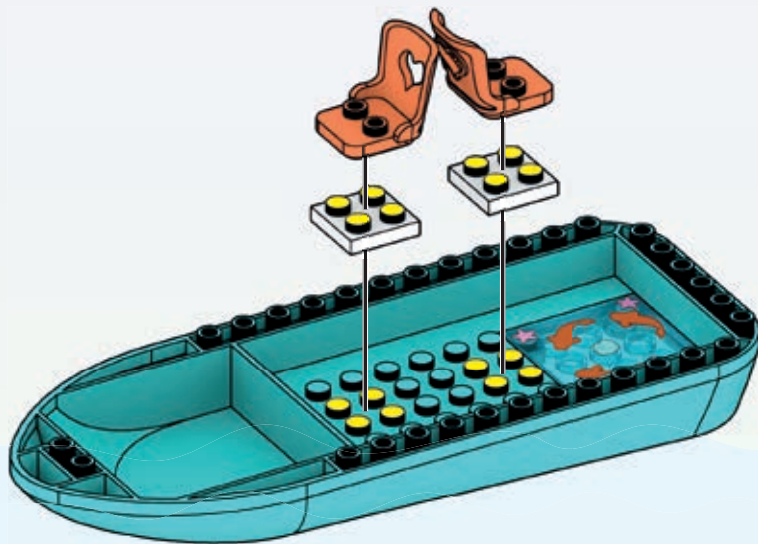

3

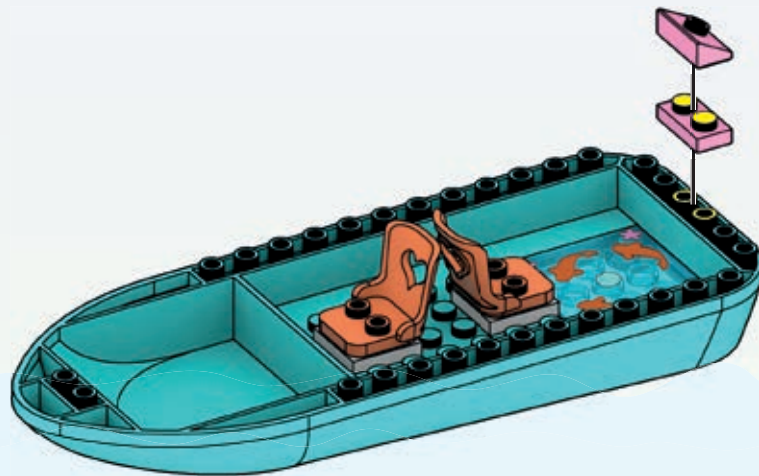

4

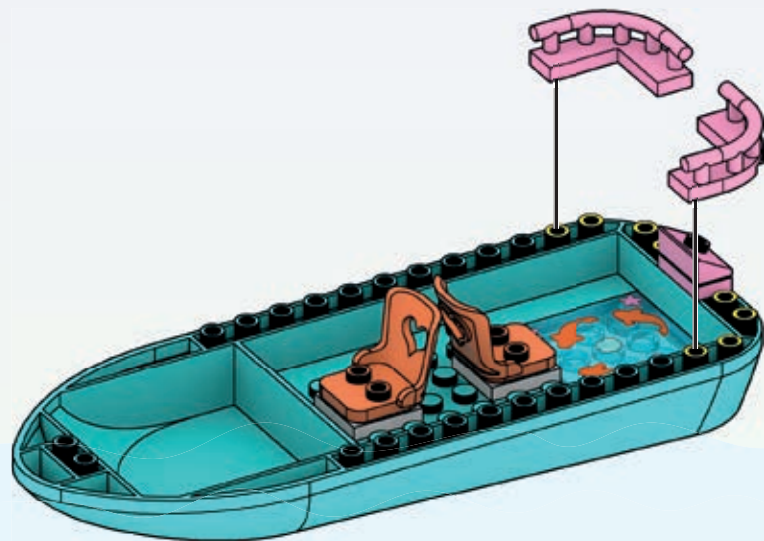

5

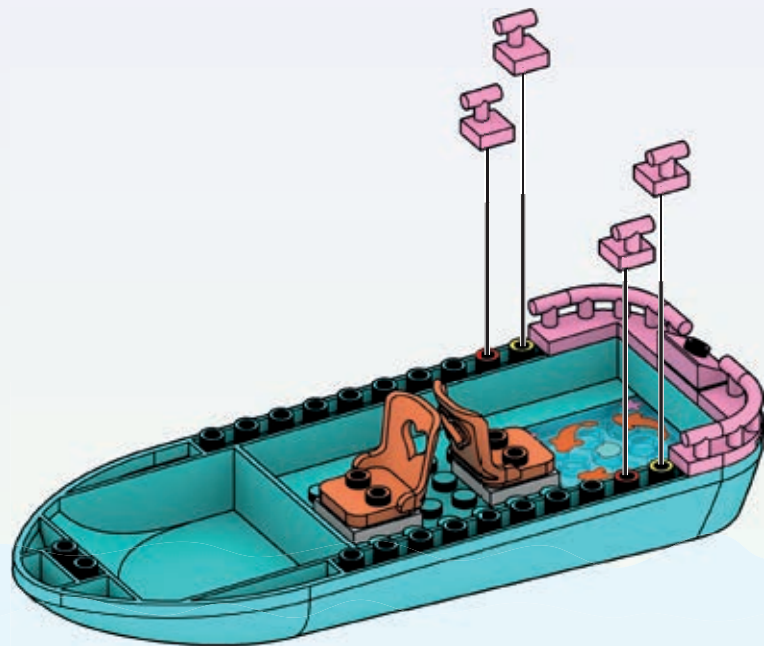

6

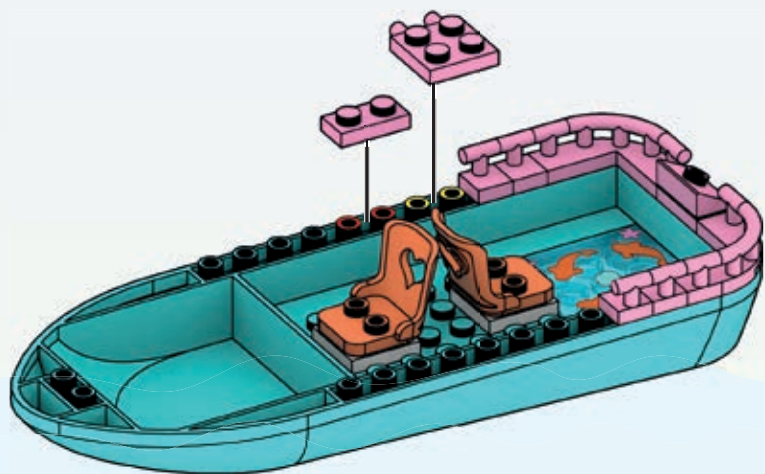
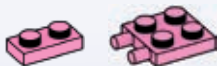

7

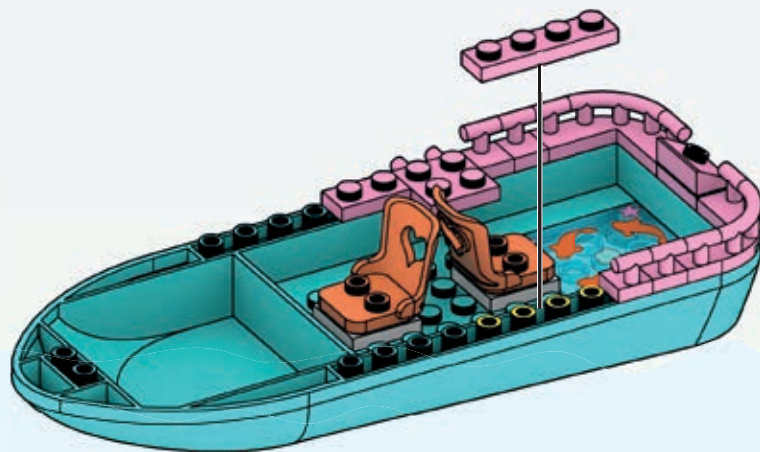



8

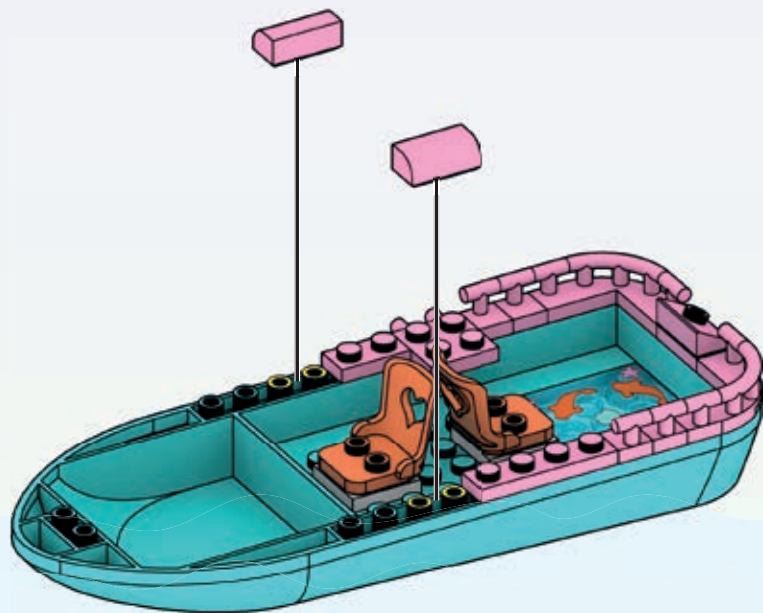

1

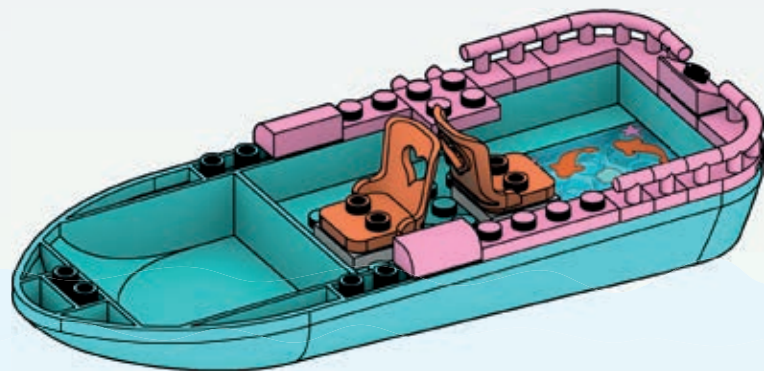

2

9

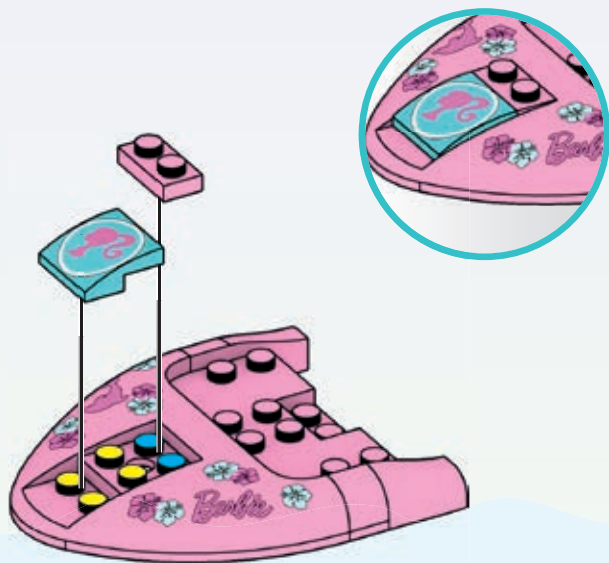
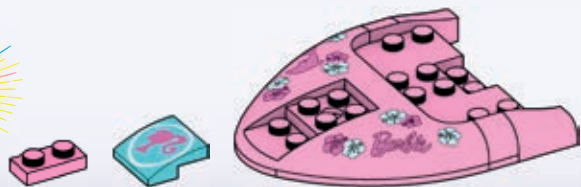

10

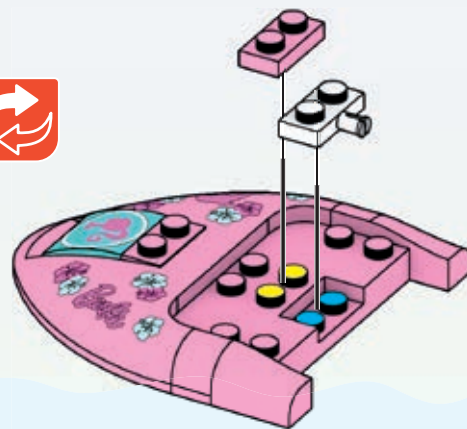

11

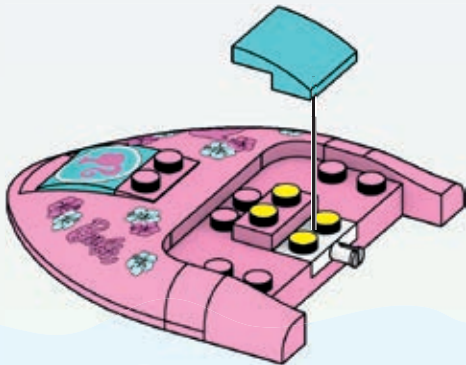

12

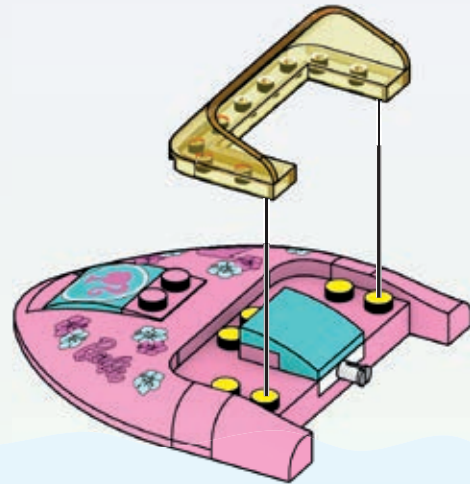

13

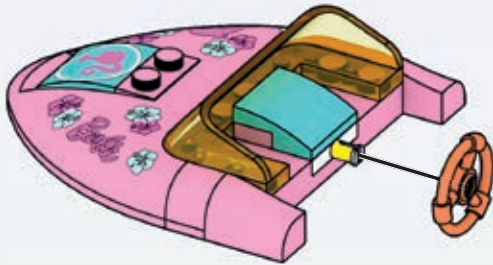

1



2

14

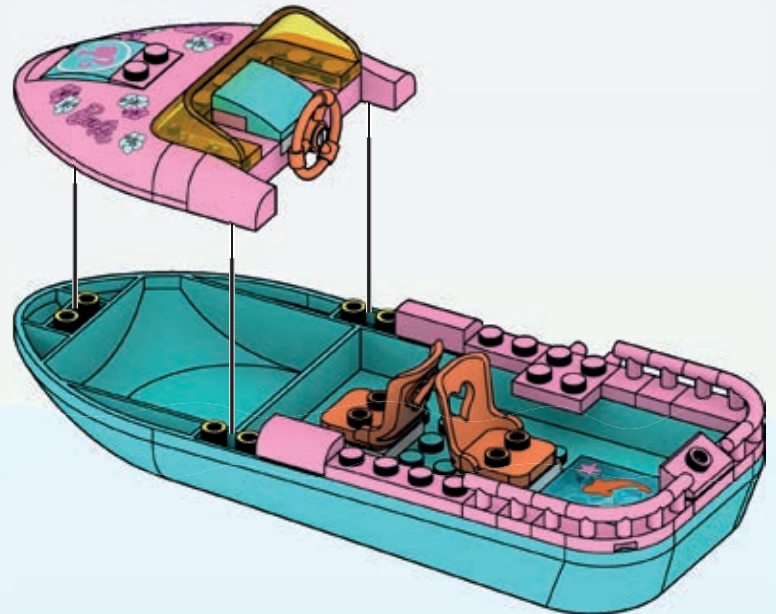

15

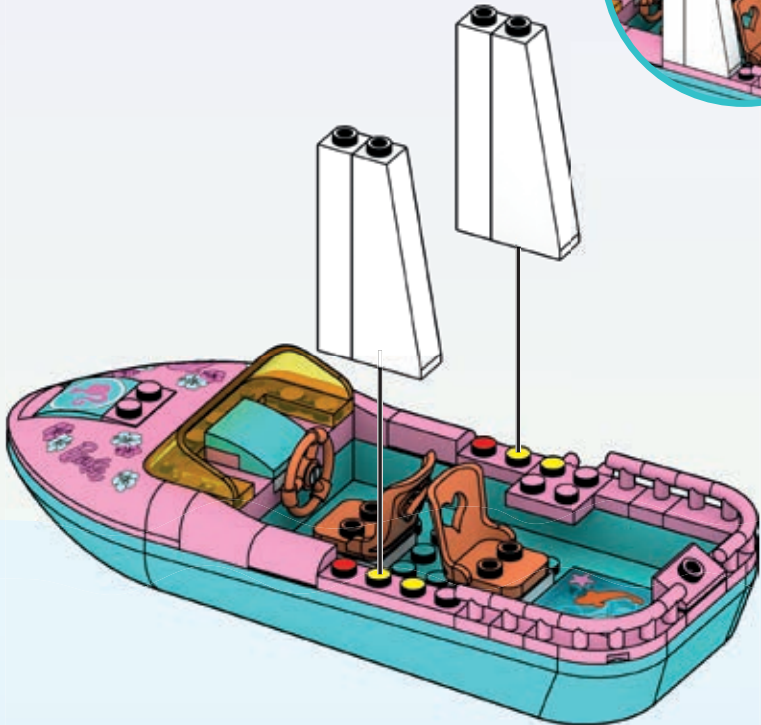
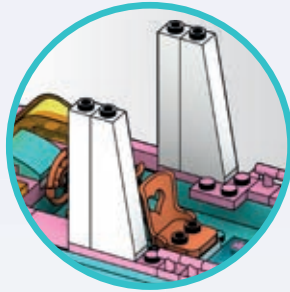
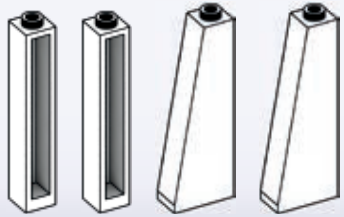

16

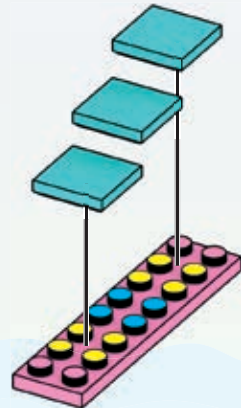
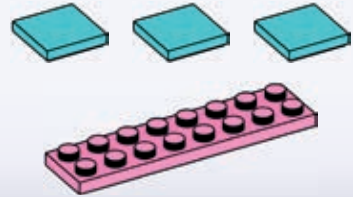

17

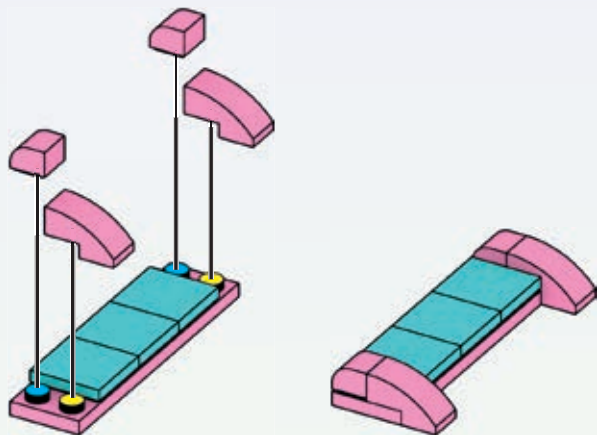

1

2

18

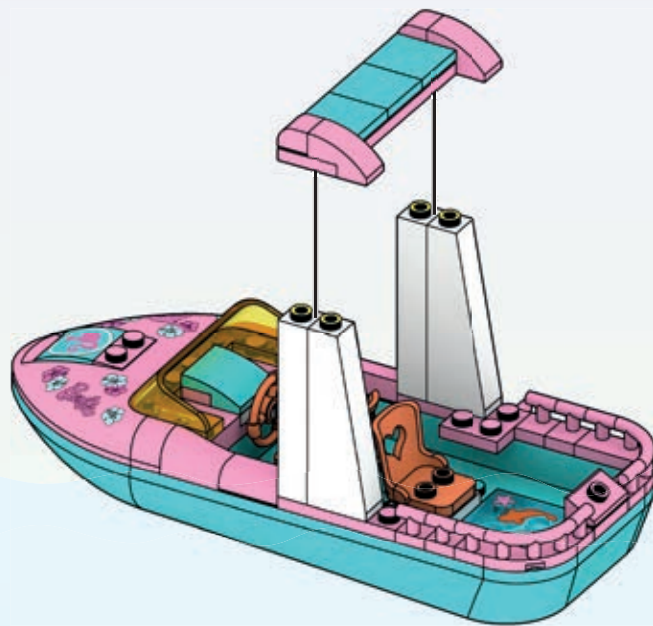

19



1



2

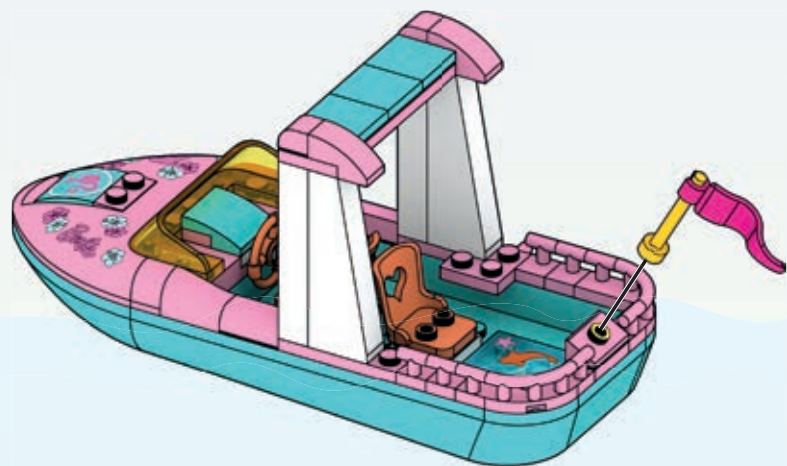

20

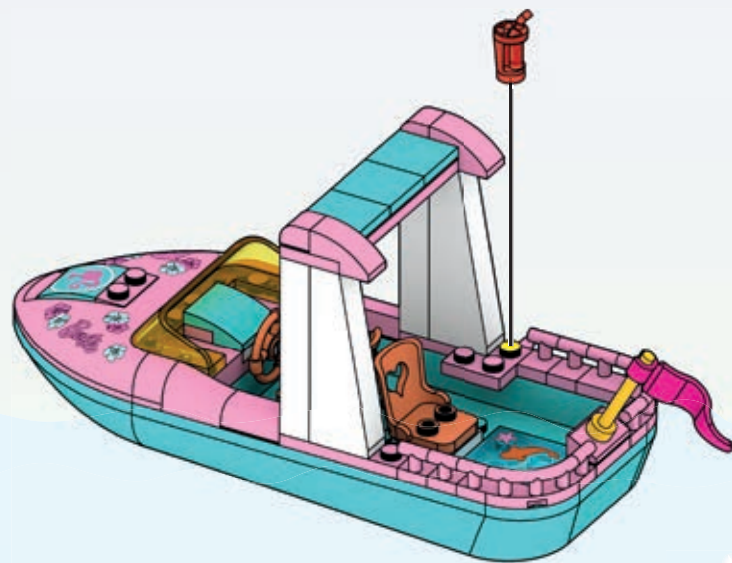

21

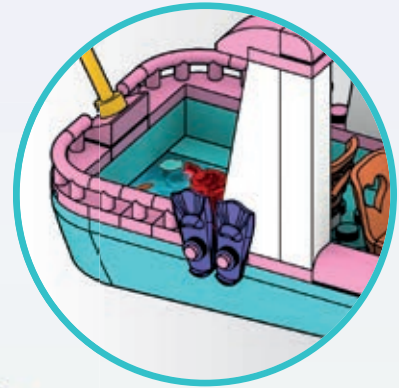
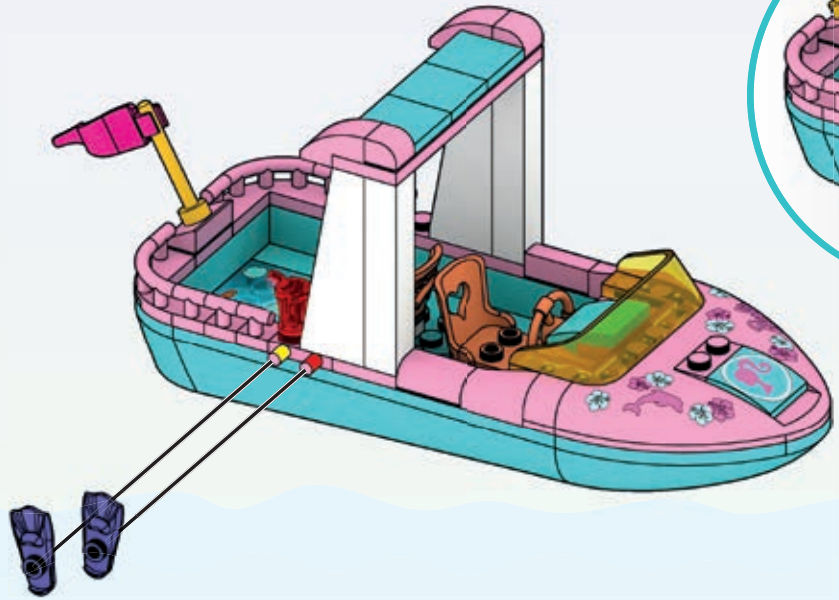



**LET'S PLAY!**  
**AMUSONS-NOUS!**  
¡AJUGAR! • A BRINCAR!  
LASS UNS SPIELEN! • НАЧИНАЕМ ИГРУ!





## LET'S BUILD THE BEACH HUT! CONSTRUISONS LE CABANON DE PLAGÉ !

¡CONSTRUYAMOS LA CABAÑA DE PLAYA!  
VAMOS CONSTRUIR A CABANA DE PRAIA!  
EINE STRANDHÜTTE BAUEN!  
ПОСТРОИМ ПЛЯЖНЫЙ ДОМИК!



## CUSTOMIZE YOUR BARBIE® MICRO-DOLL! PERSONALISEZ VOTRE MICRO-POUPÉE BARBIE®!

¡PERSONALIZA TU MICROMUÑECA BARBIE®!  
PERSONALIZE A SUA MICROBONECA BARBIE®!  
DIE BARBIE MIKROPUPPE LÄSST SICH IMMER WIEDER NEU GESTALTEN!  
СОЗДАЙТЕ СВОЮ МИКРОКУКЛУ BARBIE®!



1



2



1



2



22

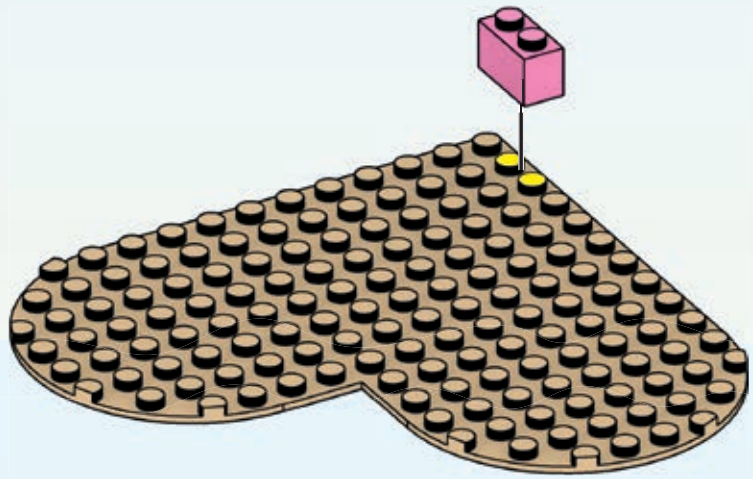
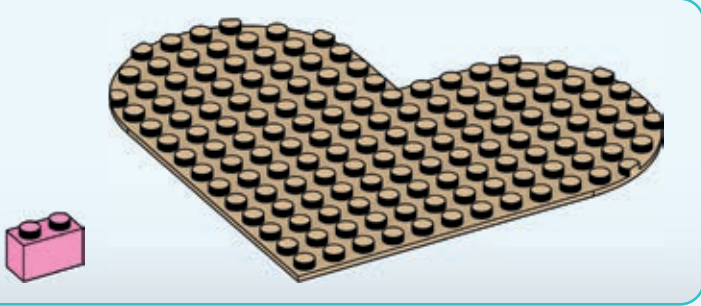

1

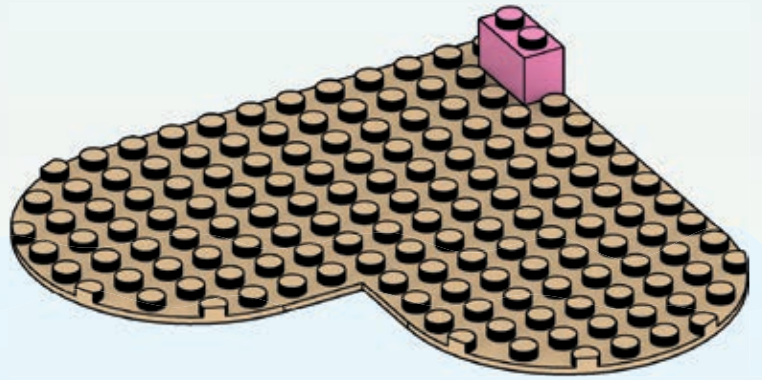

2

23

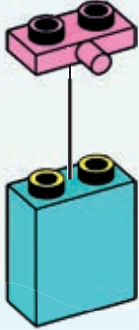
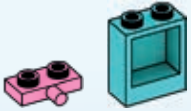

24



25

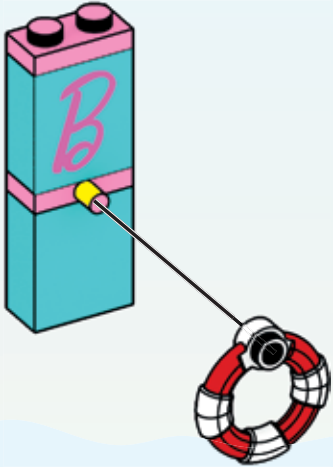
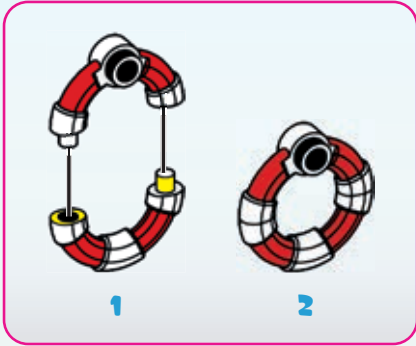
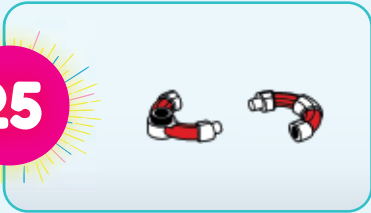

1



2

26

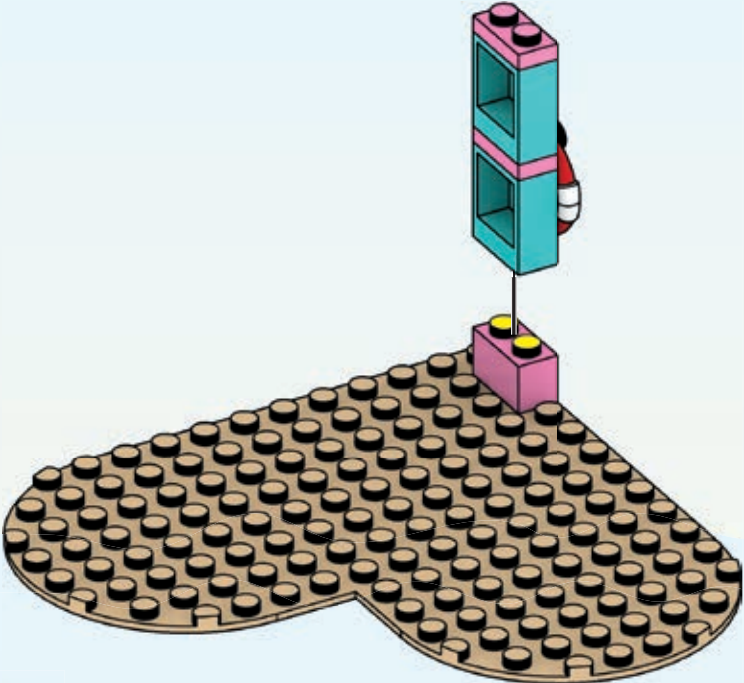

27

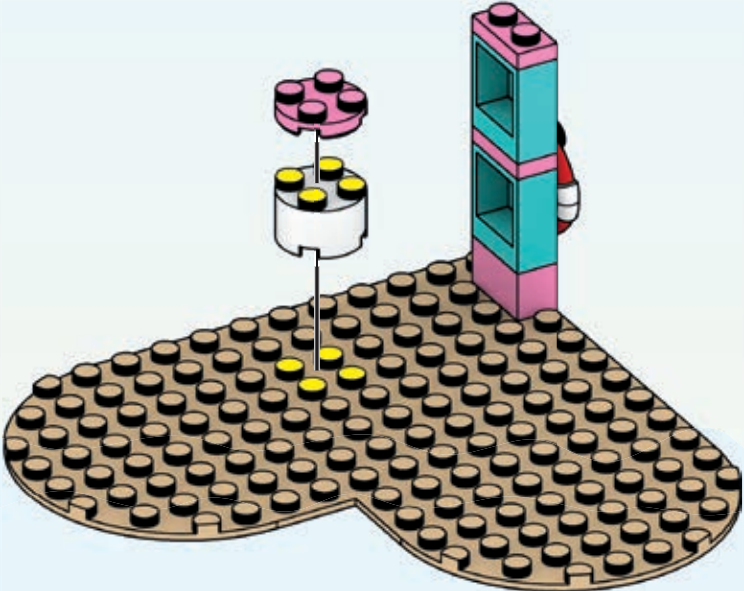

28

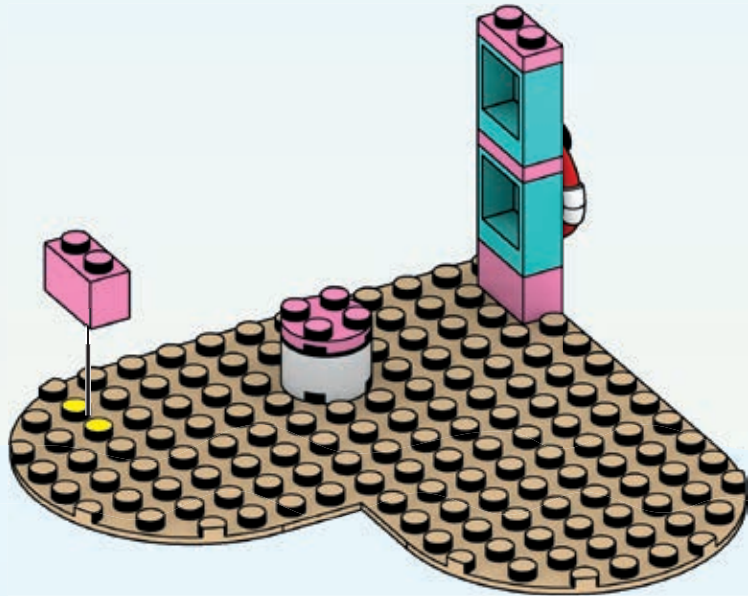

1

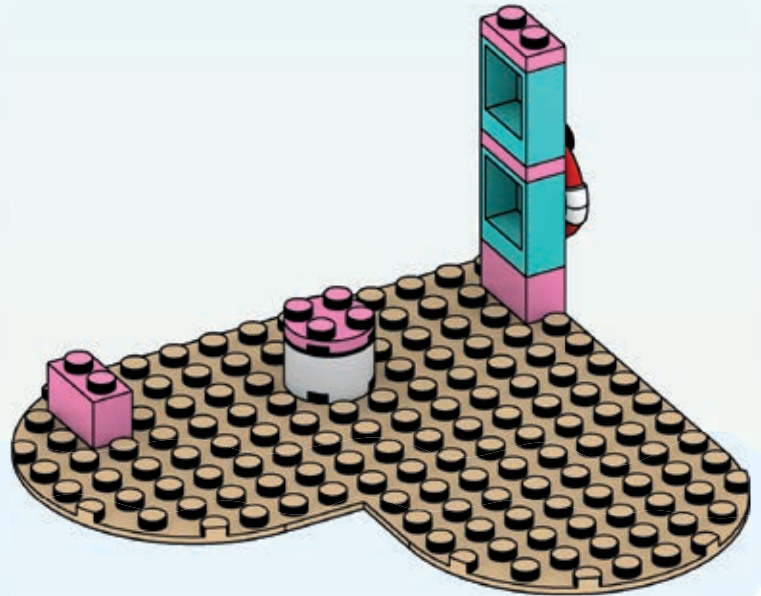

2

29

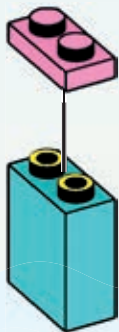

30



1

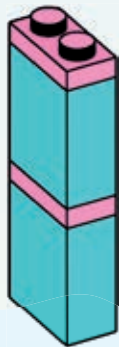

2



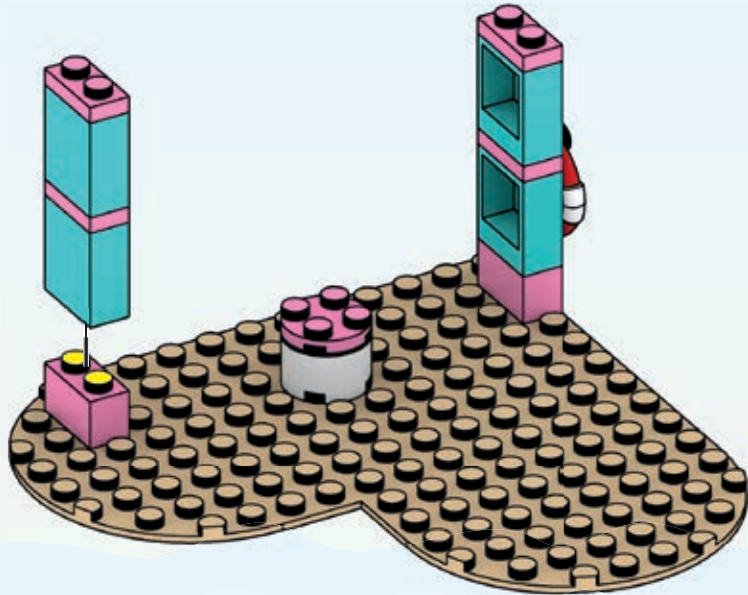

1

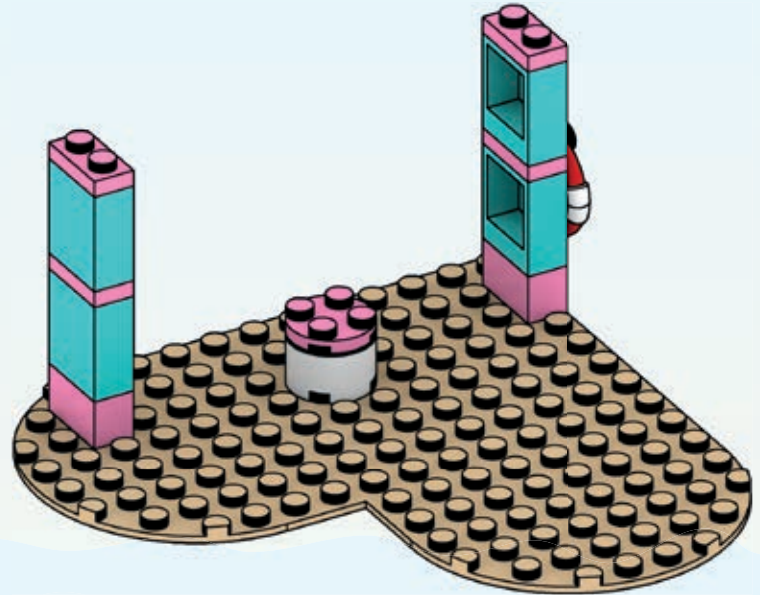

2

32

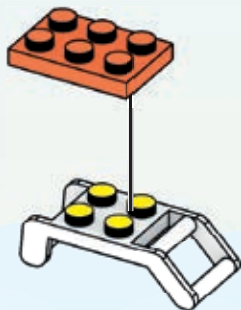
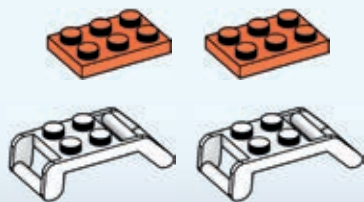

x2

33

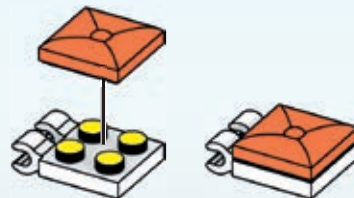

1

2

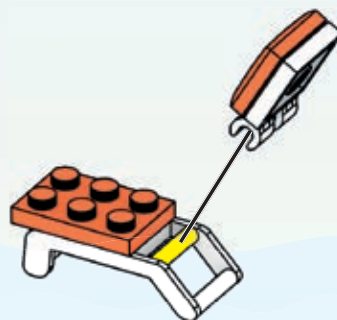

1



2

x2

34

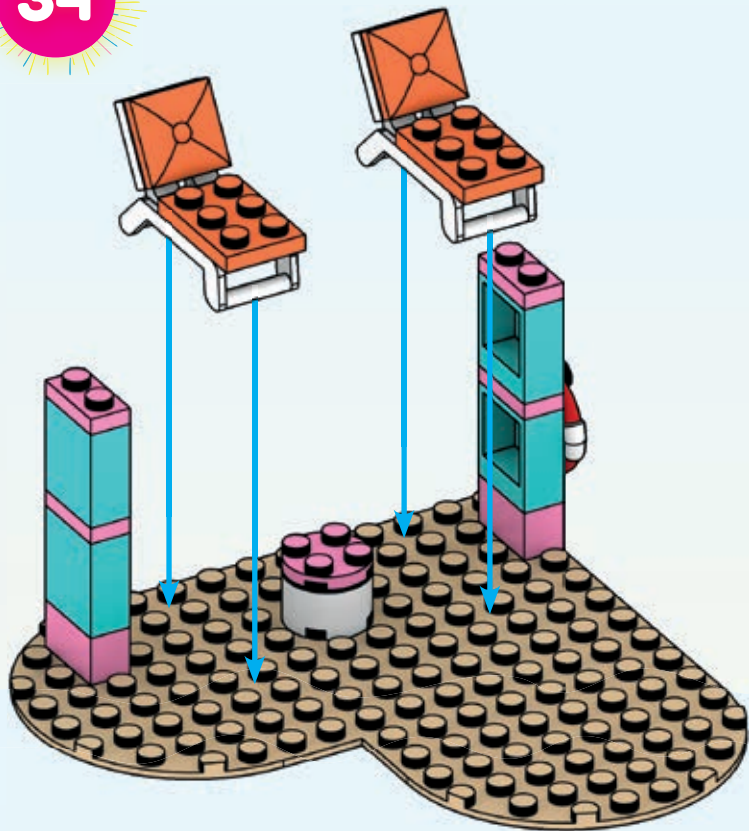

35

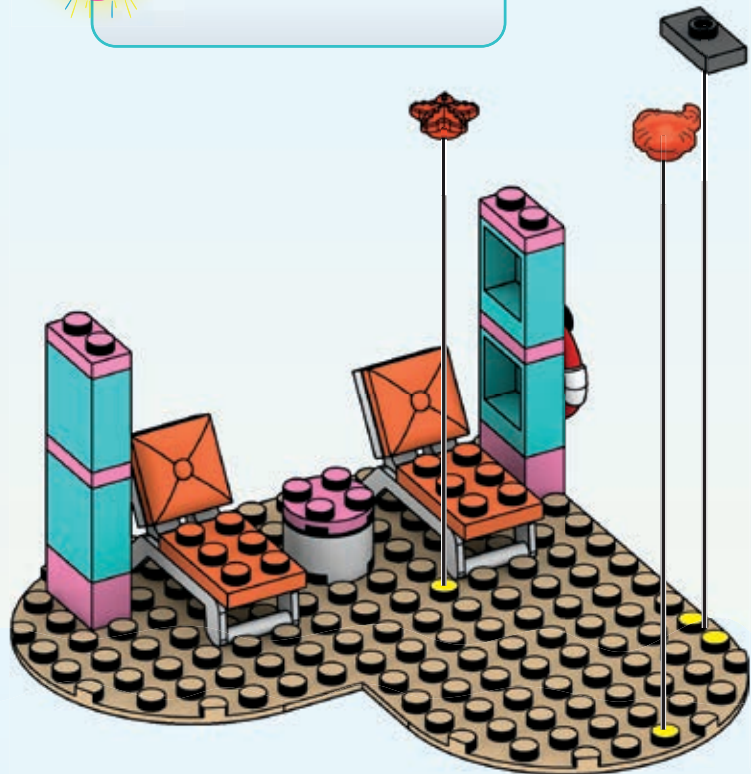

36

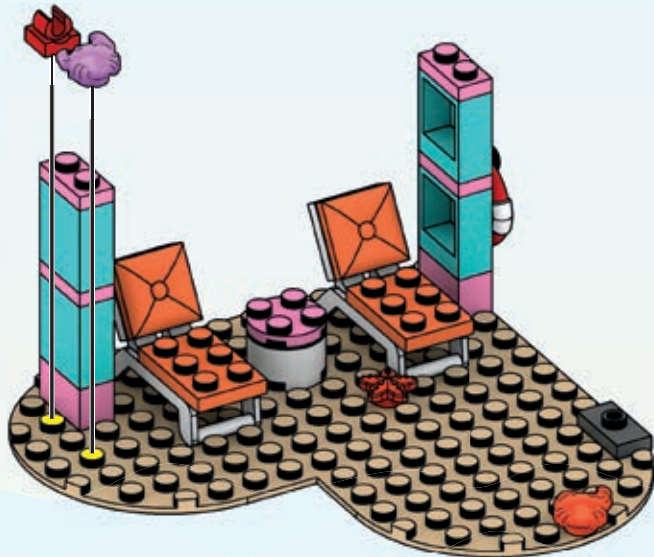

1

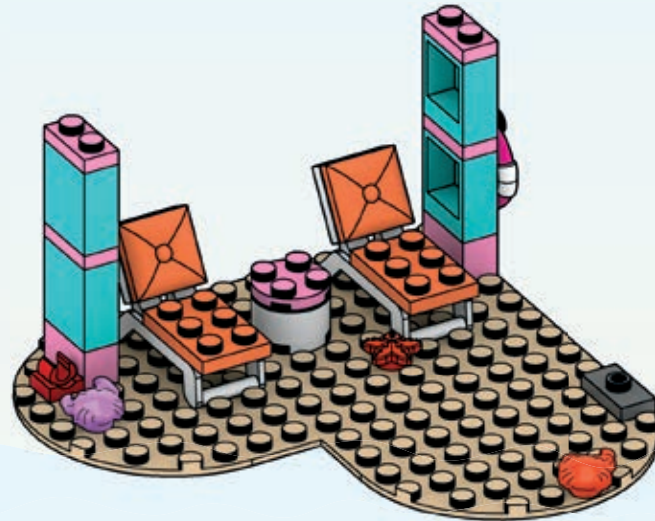

2

37

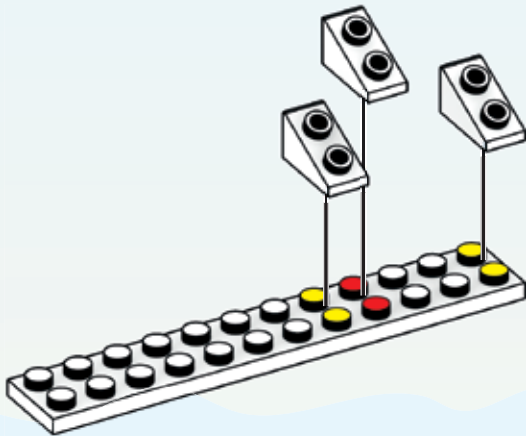
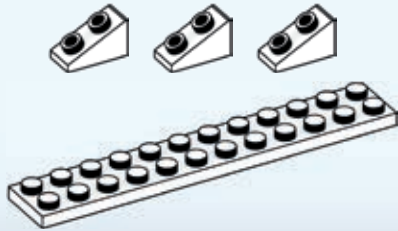

38

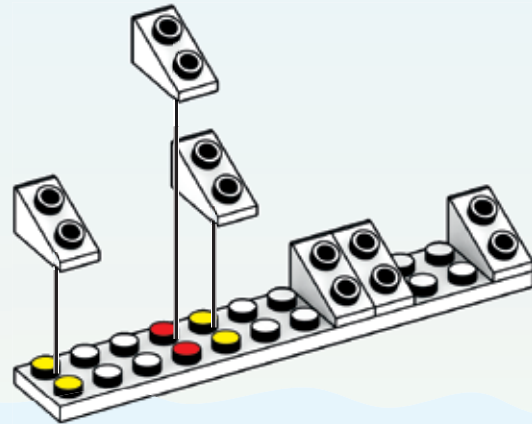

39

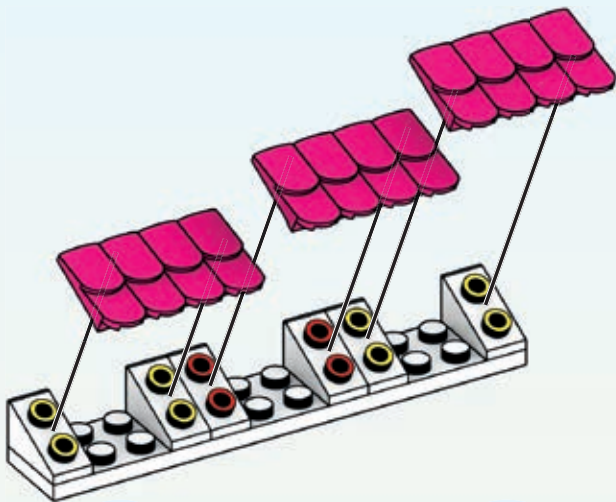

1

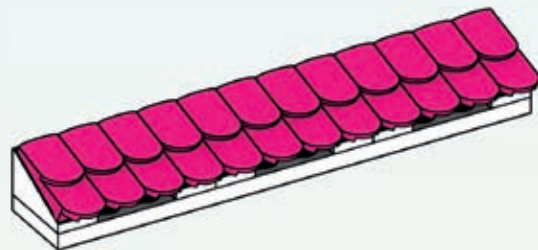

2

40



41



42



43





44



45



1



2

**LET'S PLAY!**  
**AMUSONS-NOUS!**  
¡AJUGAR! • A BRINGAR!  
LASS UNS SPIELEN! • НАЧИНАЕМ ИГРУ!





## LET'S BUILD THE DOLPHIN JUMPING HOOP! CONSTRUISONS LE CERCEAU DES DAUPHINS !

¡CONSTRUYAMOS EL ARO PARA SALTAR CON  
DELFINES!

VAMOS CONSTRUIR O ARCO DE SALTO PARA  
GOLFINHOS! EINEN SPRUNGREIFEN FÜR DELFINE  
BAUEN! ПОСТРОИМ ОБРУЧ ДЛЯ ПРЫЖКОВ  
ДЕЛЬФИНОВ!



## CUSTOMIZE YOUR BARBIE® MICRO-DOLL! PERSONALISEZ VOTRE MICRO-POUPÉE BARBIE®!

¡PERSONALIZA TU MICROMUÑECA BARBIE®!  
PERSONALIZE A SUA MICROBONECA BARBIE®!  
DIE BARBIE MIKROPUPPE LÄSST SICH IMMER WIEDER NEU GESTALTEN!  
СОЗДАЙТЕ СВОЮ МИКРОКУКЛУ BARBIE®!



1



2



46

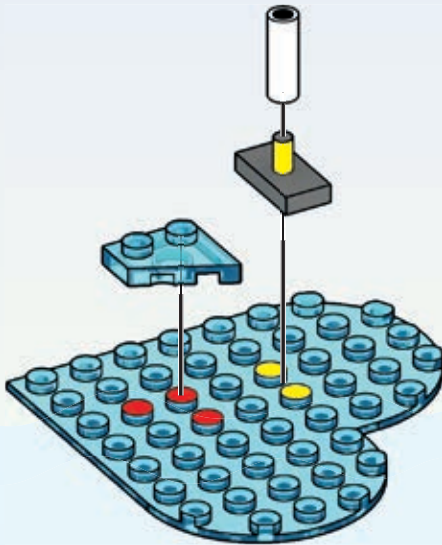
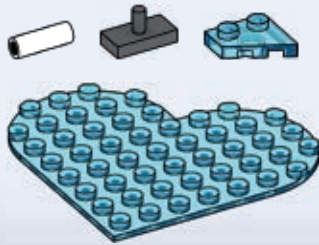

47

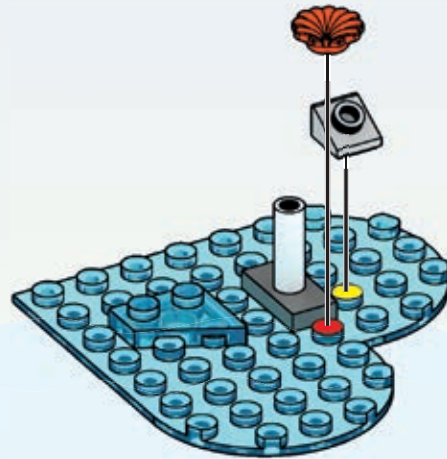

48

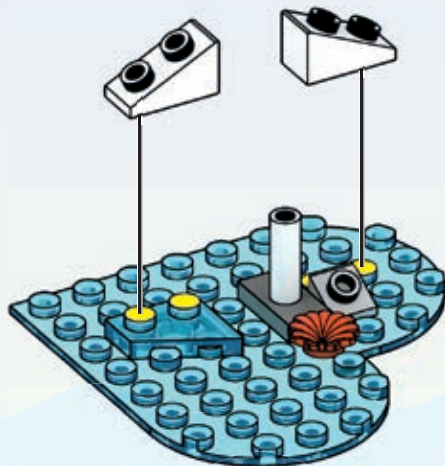

49



50

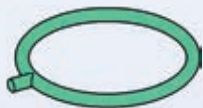

1

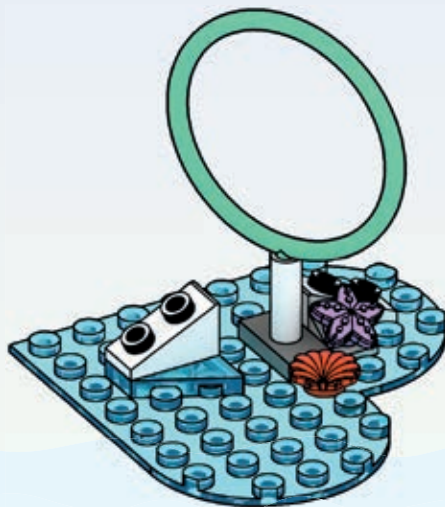

2

51

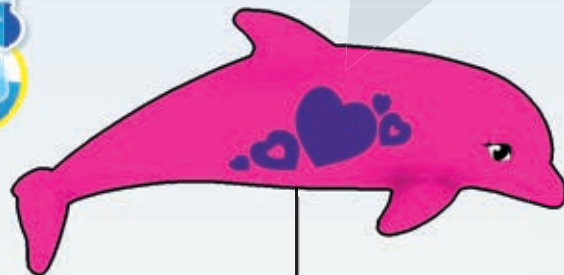

1

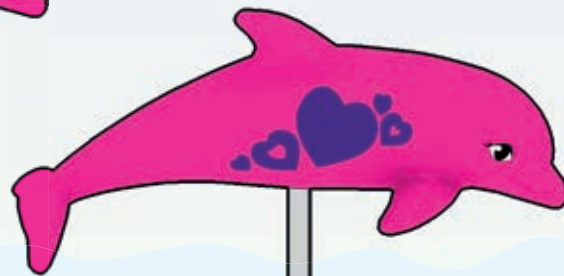

2



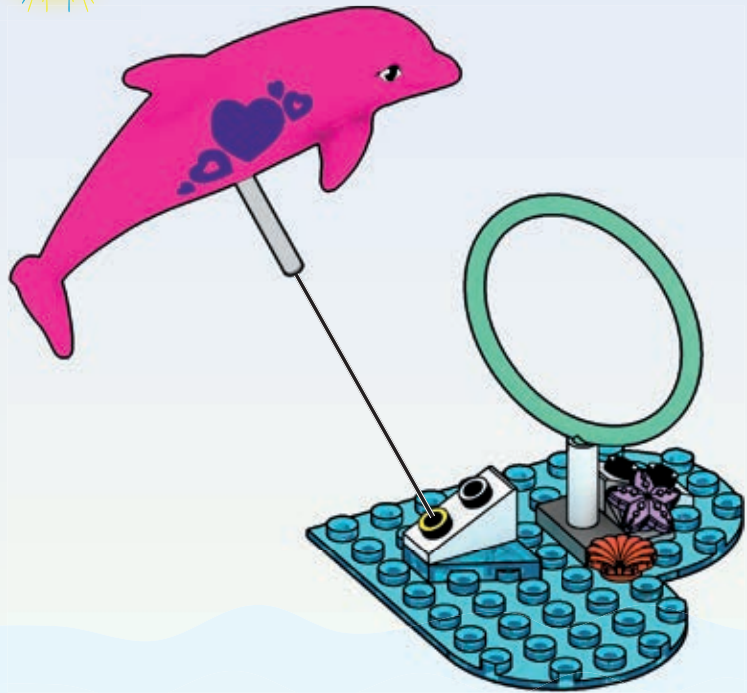

1

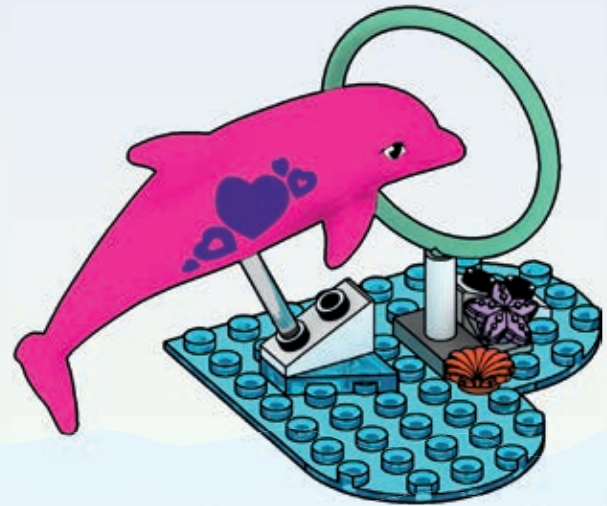

2

53



1

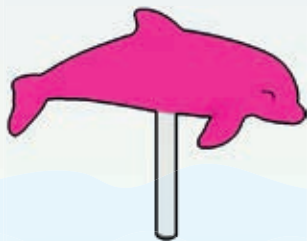

2

54

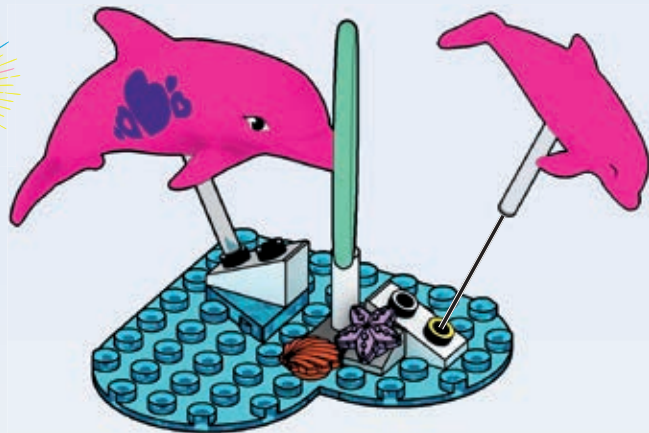

1

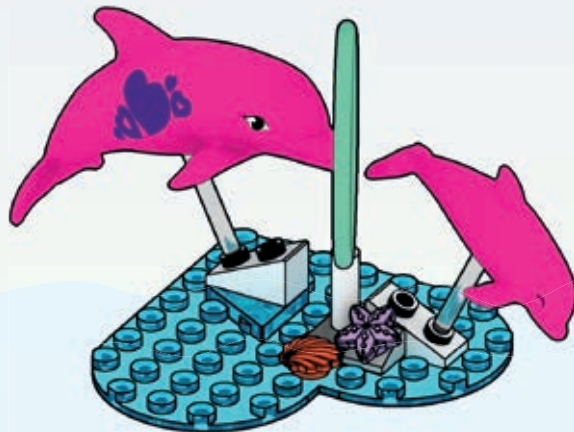

2

**LET'S PLAY!**  
**AMUSONS-NOUS!**  
 ¡AJUGAR! • A BRINGAR!  
 LASS UNS SPIELEN! • НАЧИНАЕМ ИГРУ!



This toy does not float. / Ce jouet ne flotte pas. / Este juguete no flota. / Este brinquedo não flutua. / Questo giocattolo non galleggia. / Dieses Spielzeug schwimmt nicht. / Ta zabawka nie pływa i nie unosi się na wodzie. / Dit speelgoed kan niet drijven. / Эта игрушка не держится на воде. / Dette legetøj kan ikke flyde. / Leksaken flyter inte. / Denne leken flyter ikke. / Tämä lelu ei kellu. / Αυτό το παιχνίδι δεν επιπλέει. / Bu oyuncak suda yüzmez. / Tato hračka neplave. / Táto hračka nepláva na vode. / A játék nem marad fenn a víz felszínén. / このおもちゃは水に浮かびません。 / هذه اللعبة لا تطفو على الماء. / 本产品不会漂浮于水面。

To avoid burns do not use water that is too hot, above 43°C (110°F). Water toys sometimes get messy. Protect play surfaces before use. Drain, rinse, clean and dry all items thoroughly before storing. Dissolvable paint may stain fabrics and other surfaces. Avoid contact with carpet, clothing, wall and furniture. If staining occurs, raise with soap (not included) and warm water.

Pour éviter tout risque de brûlure, n'utilisez pas d'eau trop chaude (plus de 43 °C). Les jouets d'eau peuvent éclabousser. Protégez les surfaces de jeu avant toute utilisation. Égouttez, rincez, lavez et séchez tous les éléments minutieusement avant de les ranger. La peinture soluble peut tacher certains tissus et autres surfaces. Évitez tout contact avec la moquette, les vêtements, les murs et les meubles. En cas de tache, rincez au savon (non inclus) et à l'eau tiède.

Para evitar quemaduras, no utilitzar aigua demasiado calienta (por encima de 43 °C). Los juguetes que requieren agua pueden ensuciar la superficie de juego. Se debe proteger antes de empezar a jugar. Es necesario limpiar, aclarar y secar todas las piezas antes de guardar el juguete. La pintura disolvente puede manchar o adherirse a algunos tejidos y otras superficies. Se recomienda evitar el contacto con alfombras, moqueta, ropa, paredes y muebles. Si se producen manchas, lavar con jabón (no incluido) y agua templada.

Para evitar quemaduras, não utilizar água demasiado quente, acima dos 43 °C. Os brinquedos que requerem a utilização de água podem sujar a área de brincadeira. Proteger a área de brincadeira antes de brincar. Lavar, enxaguar, limpar e secar bem todos os acessórios antes de guardar. A tinta dissolúvel pode manchar os tecidos e outras superfícies. Evitar o contacto com tapetes, roupa, paredes e mobília. Se provocar manchas, enxaguar com sabão (não incluído) e água morna.

Per prevenire le ustioni, non usare acqua troppo calda, oltre 43°C. I giochi ad acqua possono creare disordine. Proteggere le superfici di gioco prima dell'utilizzo. Svuotare, risciacquare, pulire e asciugare accuratamente tutte le componenti prima di riporle. La vernice solubile può macchiare tessuti e altre superfici. Evitare il contatto con tappeti, abiti, pareti e mobili. In caso di macchie, risciacquare con sapone (non incluso) e acqua calda.

Um Verbrennungen zu vermeiden, kein Wasser benutzen, das zu heiß ist (über 43°C). Wasserspielzeuge können spritzen! Die Spielfläche vor dem Spielen abdecken. Nicht auf Oberflächen spielen, die durch Wasser Schaden nehmen können. Alle Spielteile vor dem Weglegen gründlich säubern und trocknen. Die lösliche Farbe kann auf einigen Stoffen und anderen Oberflächen Flecken hinterlassen. Nicht mit Teppich, Kleidung, Wänden oder Möbeln in Berührung bringen. Etwaige Flecken mit warmem Wasser und Seife (nicht enthalten) auswaschen. Aby uniknąć oparzeń, nie używaj zbyt gorącej wody (o temperaturze powyżej 43°C). Zabawki, którymi można bawić się przy użyciu wody, mogą powodować nieporządek. Przed rozpoczęciem zabawy zabezpiecz przeznaczoną do niej powierzchnię. Opróżnij z wody, oplucz, oczyść i wysusz wszystkie części zabawki przed ich schowaniem. Rozpuszczalna farba może plamić tkaniny i inne powierzchnie. Unikaj kontaktu z dywanami, odzieżą, ścianami i meblami. W przypadku wystąpienia zabrudzeń spłucz je ciepłą wodą z mydłem (nie znajduje się w zestawie).

Gebruik, om brandwonden te voorkomen, geen water warmer dan 43°C. Bij het spelen met water kan er nogal eens wat nat worden. Dek voor het spelen het speelgedeelte goed af. Voor het opbergen alle onderdelen leeg laten lopen, schoonspoelen en goed afdrogen. Oplosbare verf kan vlekken veroorzaken op stoffen en andere oppervlakken. Vermijd contact met tapijt, kleding, wanden en meubels. Als ergens vlekken in komen, spoel je deze af met zeep (niet meegeleverd) en warm water.

Во избежание ожогов не используйте слишком горячую воду, температура которой превышает 43°C. Игрушки, предназначенные для игр с водой, иногда становятся причиной беспорядка. Перед началом игры подготовьте все необходимое для защиты поверхности игровой зоны. Перед тем как убрать изделия на хранение, ополосните, почистите и протрите их насухо. Растворимая краска может оставить пятна на тканях и других поверхностях. Избегайте контакта с коврами, одеждой, стенами и мебелью. Если пятна появились, отстирайте их в теплой воде при помощи мыла (не входит в комплект).

Играшки, предназначенные для игр с водой, иногда становятся причиной беспорядка. Перед началом игры подготовьте все необходимое для защиты поверхности игровой зоны. Перед тем как убрать изделия на хранение, ополосните, почистите и протрите их насухо. Растворимая краска может оставить пятна на тканях и других поверхностях. Избегайте контакта с коврами, одеждой, стенами и мебелью. Если пятна появились, отстирайте их в теплой воде при помощи мыла (не входит в комплект).

Undgå forbrændinger ved ikke at bruge vand, der er over 43 °C. Når man leger med vandlegetøj, kan legeområdet blive vådt. Beskyt legeområdet inden brug af legetøjet. Tom, skyl, rengør og tør alle dele grundigt, inden de lægges væk. Oploselig farve kan efterlade pletter på stof og andre overflader. Undgå kontakt med tæpper, tøj, vægge og møbler. Skyl efter med varmt sæbevand (medfølger ikke), og tør dem grundigt.

Undvik brännskador, använd inte vatten som är varmare än 43°C. Vattenleksaker kan orsaka spill. Skydda underlaget före lek. Töm, skölj, tvätta och torka alla delar innan du lägger undan dem för förvaring. Vattenlöslig färg kan ge fläckar på tyger och andra material. Undvik kontakt med mattor, tyger, väggar och möbler. Om fläckar uppstår, skölj med tvål (ingår inte) och varmt vatten.

For å unngå forbrenninger må du ikke bruke vann som er varmere enn 43 °C. Vannleker kan medføre mye søl. Beskytt lekkeflaten før bruk. Tom, skyl, rengjør og tørk alle delene grundig før oppbevaring. Den oppløselige malingen kan lage flekker på stoff og andre overflater. Unngå kontakt med tepper, klær, vegger og møbler. Hvis det blir flekker, skyller du med såpe (medfølger ikke) og varmt vann.

Vältä palovammat – älä käytä liian kuumaa vettä (yli 43 °C). Vesleikeistä saattaa syntyä sotkuja. Suojaa leikkipaikka ennen leikin aloitusta. Tyhjennä, huuhdo, puhdista ja kuivaa kaikki osat hyvin ennen kuin panet ne säilöön. Maali voi vahrata kankaita ja muita materiaaleja. Varo, ettei sitä joudu matolle, vaatteille, seinille eikä huonekaluille. Poista tarvittaessa tahrat saippualla ja lämpimällä vedellä.

Για να αποφύγετε εγκαύματα μη χρησιμοποιείτε πολύ ζεστό νερό άνω των 43°C. Κάποιες φορές τα παιχνίδια με νερό προκαλούν ακαταστασία. Προστατέψτε την επιφάνεια του παιχνιδιού πριν από τη χρήση. Καθαρίστε και στεγνώστε καλά όλα τα αντικείμενα πριν την αποθήκευσή τους. Η διαλυτή μπογιά μπορεί να λερώσει υφάσματα και άλλες επιφάνειες. Αποφύγετε την επαφή με χαλιά, ρούχα, τοίχους και έπιπλα. Αν γίνει λεκέξ, καθαρίστε τον με ζεστό νερό και σαπούνι (δεν περιλαμβάνεται).

Yanma riskini önlemek için ürünü 43°C' den yüksek sıcaklığa su ile kullananmayın. Suyula oynanan oyuncaklar etrafı istablatılır. Oyuncakları kullandıktan önce oyun alanını ıslanmaya karşı koruyun. Oyun setini kaldırıldan önce tüm parçaların suyunu süzün, parçaları durulayın, temizleyin ve kurutun. Çözünür boyalar, kumaşları ve diğer yüzeyleri lekeleyebilir. Ürünü 43°C'nin üzeri, duvar ve mobilyalara temas ettirmeyin. Lekelenen yüzeyi sabun (ürünü dahil değildir) ve ılık suyla temizleyin.

Nepoužívejte příliš horkou vodu (o teplotě vyšší než 43 °C), aby předešlo opaření. Hračky na vodu mohou způsobit nepořádek. Před použitím zakryjte povrchy, kde si budete hrát. Před uloženíím všechny předměty opláchněte, vyčistěte, nechte je okapat a důkladně vyschnout. Rozpustná barva může zanechat skvrny na tkaninách a jiných površích. Zabraňte kontaktu s koberci, oděvy, stěnami a nábytkem. Skvrny od barvy odstraníte opláchnutím teplou vodou s mýdlem (není součástí balení).

Nepoužívejte příliš horúcu vodu s teplotou nad 43°C (110°F), aby sa predišlo popáleniu. Hračky do vody občas spôsobia neporiadok. Pred použitím zabezpečte hraciu plochu pred pokodením. Pred uloženíím všetky diely dôkladne vyprádňte, opláchnite, očistite a vysušte. Rozpustná farba môže zašpiniť textilie a iné povrchy. Zamedzte kontaktu s kobercami, odevom, stenami a nábytkom. V prípade znečistenia opláchnite mydlom (nie je súčasťou balenia) a teplou vodou.

Az égési sérülések elkerülése érdekében a víz ne legyen nagyon forró, hőmérséklete ne haladja meg a 43°C fokot. A vízi játékokkal játszó gyerekek kisebb-nagyobb rendeltenségek okozhatnak. Használat előtt gondoskodjon a játszófelület védelméről. Törölés előtt irtse ki, öblítse le, tisztítsa meg és hagyja teljesen megszáradni a játék minden részét. A feloldódó festék elszínezheti a szöveteket és más felületeket. Lehetőleg ne érjen hozzá szőnyeghez, ruházathoz, falhoz és bútorokhoz. Ha foltot hagyta, öblítse le szappannal (nem tartozék) és meleg vízzel.

やけどしないように、43度以上の熱すぎないお湯をご使用ください。水を使用したおもちゃは周囲を汚す可能性があります。周囲をぬらさないように注意し、使用後は水道水で洗いタオルでふいて乾かしてください。色素が周囲を汚す可能性があります。カーペット、衣服、壁や家具などにつかないようにしてください。汚れがつかいたらすぐに洗剤をたかしたぬるま湯でふいてください。

يجب عدم استخدام الماء الساخن جداً الذي تتجاوز حرارته 43 درجة مئوية (110 فهرنهايت) لتفادي حدوث أية حروق. أحياناً، قد تسبب الألعاب المائية بعض الفوضى. يجب تأمين ساحات اللعب قبل استخدامها. يجب تصفية قطع الألعاب وتغفيفها ونظفها وتنظيفها قبل تخزينها. تجنب ترك الأوان الطلاء بضعاً على الأسطح. يجب تجنب ملامسة السجاد والملابس والجدار والأثاث. في حال حدوث البقع يجب الغسل بالماء الدافئ والصابون (غير متضمن).

防止水温太高导致烫伤，请不要使用温度大于43摄氏度（110华氏度）的水。在水中玩耍的玩具通常较容易弄脏。请在玩耍前好好保护玩具表层。在存储玩具之前请将玩具中的水彻底排干，进行清洗以及烘干。可溶解的涂层可能会弄脏纺织物品或者其他物体的表面。防止与地毯，衣物，墙壁以及家具接触。如果发生弄脏的情况，请用肥皂（产品不包含）以及温水进行清洗。

1x  
AM75172MCX



1x  
AM17506E



1x  
AM73035X



1x  
AM18665AAV



3x  
AM78953VL



3x  
AM03872ASU



1x  
AM09593ASX



1x  
AM75172NL



1x  
AM07590BDG



1x  
AM73035HJ



3x  
AM0948ASU



1x  
AS-HHW83-06



1x  
AS-HHW83-09



2x  
AM77415ASX



1x  
AM81341ZD



1x  
AM75171NL



7x  
AM09393ASX



1x  
AM74677ASX



2x  
AM72956AAD



1x  
AS-HHW83-07



1x  
AS-HHW83-09



3x  
AM81161ATC



1x  
AM72844ACS



1x  
AM75171MCX



1x  
AM79563ASX



1x  
AM78500AAD



2x  
AM03773E



2x  
AM73433AMP



2x  
AM81142AAD



2x  
AM73184E



1x  
AM08483ASX



2x  
AM17787ASX



1x  
AM18221E



8x  
AM04429E



1x  
AM74314ASX



2x  
AM03772AAD



2x  
AM16289E



1x  
AS-HHW83-02



1x  
AS-HHW83-04

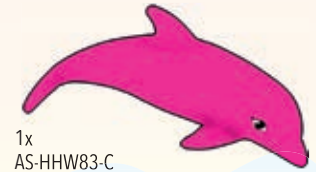

1x  
AM75173NL



1x  
AM73989ASX



2x  
AM09013ASX



1x  
AM74106ASU



2x  
AM76521W



2x  
AM16289E



1x  
AS-HHW83-02



1x  
AS-HHW83-C

1x  
AM72001BLG



2x  
AM03017ASX



1x  
AS-HHW83-05



1x  
AS-HHW83-01



1x  
AM18593BYE



2x  
AM03767E



1x  
X-HHP89-01



1x  
AM19999AMC



1x  
AM17070BDG



1x  
AM01320E



2x  
AM18328E



1x  
AM16450ATC



2x  
AM03767E



1x  
AS-HHW83-D



1x  
AM72900HT

1x  
AM72922I



2x  
AM17788ASX



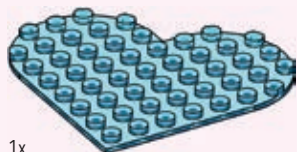

1x  
AM81104AAV



1x  
AS-HHW83-03



1x  
AM81472ASU



1x  
AM01172E

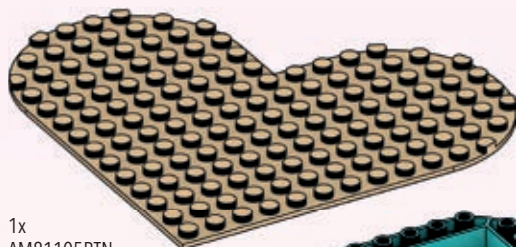

1x  
AM81105BTN

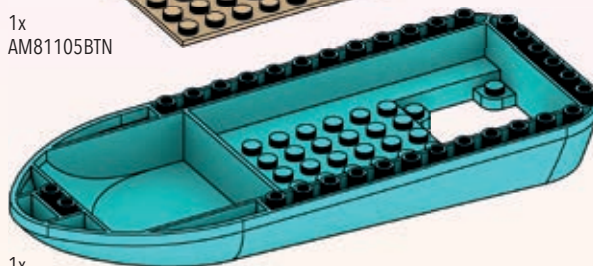

1x  
AM81339ASU

DOLPHIN EXPLORATION | L'OBSERVATION DES DAUPHINS | DELFINABENTEUER | SET AMICI DELFINI | DOLFINAVONTUUR | EXPLORACIÓN CON DELFINES | EXPLORAÇÃO DE GOLFINHOS | DELFINEXPEDITION | DELFINEVENTYR | PRZYGODA Z DELFINAMI | OBJAVOVANJE S DELFINMI | DELFINKALAND | YUNUS KEŞİF | НАБОР "В ПОИСКАХ ДЕЛЬФИНОВ" ИЗ КОЛЛЕКЦИИ "СЮРПРИЗ" | ΕΞΕΡΥΝΗΣΙΣ ΣΤΗ ΘΑΛΑΣΣΑ | استكشاف الدلفين

**Color change will last longer if you do not expose this toy to intense heat or direct sunlight for prolonged periods of time.**  
**Le changement de couleur peut tenir plus longtemps si vous n'exposez pas ce jouet à une chaleur intense ou à la lumière directe du soleil pendant de longues durées.** / El cambio de color durará más tiempo si no expone este juguete al calor intenso o a la luz solar directa durante períodos de tiempo largos. / A mudança de cor durará mais se você não expor este brinquedo ao calor intenso ou à luz solar direta por períodos prolongados. / L'effetto cambia colore durerà più a lungo se questo giocattolo non viene esposto al calore intenso o alla luce diretta del sole per periodi di tempo prolungati. / Die Farbveränderung ist nachhaltiger, wenn das Spielzeug nicht über einen längeren Zeitraum hinweg starker Hitze oder direkter Sonneneinstrahlung ausgesetzt wird. / Zmiana koloru będzie trwała, jeśli zabawka nie będzie długookresowo narażana na wysoką temperaturę lub bezpośrednie działanie promieni słonecznych. / De verandering van kleur gaat langer mee als je dit speelgoed niet voor langere tijd aan intense hitte of direct zonlicht blootstelt. / Цвет будет дольше оставаться без изменений, если вы не будете подвергать эту игрушку продолжительному и сильному воздействию тепла или прямого солнечного света. / Farveændringen vil vare længere, hvis du ikke udsætter legetøjet for intens varme eller direkte sollys i længere perioder. / Färgändringen varar längre om du inte utsätter leksaken för stark värme eller direkt solljus under längre tidsperioder. / Färgændringen vil vare lenger hvis du ikke utsætter denne leken for sterk varme eller direkte sollys over lengre tid. / Värimuutos kestää pidempään, jos et altista tätä lelua voimakkaalle kuumuudelle tai suoralle auringonvalolle pitkää aikojä. / Η αλλαγή χρώματος θα διαρκέσει περισσότερο εάν δεν εκθέτετε αυτό το παιχνίδι σε έντονη ζέση ή άμεσο ηλιακό φως για παρατεταμένες περιόδους. / Bu oyuncuğu uzun süre yoğun ısıya veya doğrudan güneş ışığına bırakmadığınız sürece, renk değişimi uzun sürecektr. / Změna barvy vydrží déle, pokud tato hračka nebude delší dobu vystavena intenzivnímu teplu nebo přímému slunečnímu záření. / Zmena farby vydrží dlhšie, ak túto hračku nebudete dlhší čas vystavovať intenzívnemu teplu alebo priamemu slnečnému žiareniu. / A színváltozás tovább tart, ha nem teszi ki ezt a játékot hosszú ideig erős hő vagy közvetlen napfény hatásának. / 色変わりは本玩具を長時間にわたり猛烈な暑さや直射日光にさらさなければより長く持続します。 / تغيير لون يدمو طويلا في حال تجنب تعرض هذه اللعبة لدرجات الحرارة العالية أو ضوء الشمس المباشر لفترات زمنية طويلة.

如果玩具能避免长时间暴露于高温或阳光直射下，变色的有效时间会更长。



1x  
FIG-HHW83-A



1x  
FIG-HHW83-B

**Missing pieces? • Pièces manquantes?**

¿Partes faltantes? • Perdeu peças?  
Fehlern Teile? • Не хватает деталей?

[support.megabrand.com](http://support.megabrand.com)

**ATTENTION : DANGER**  
D'ÉTOUFFEMENT. - PRÉSENCE DE PETITS  
ÉLÉMENTS. NE CONVIENT PAS AUX ENFANTS DE  
MOINS DE 3 ANS.

**ATENÇÃO!** NÃO INDICADO / NÃO  
RECOMENDÁVEL PARA CRIANÇAS MENORES DE 3  
(TRÊS) ANOS POR CONTER PARTE(S) PEQUENA(S)  
QUE PODÊ(M) SER ENGOLIDA(S) OU ASPIRADA(S)  
PODENDO PROVOCAR ASFIXIA.

警告：  
のどにつまる危険 小さな部品が含まれています  
3歳以下の子供には与えないで下さい。

**警告!**  
不适合3岁以下儿童使  
用。内含小零件。

⚠️ **WARNING : CHOKING HAZARD.** - Small parts.  
Not for children under 3 years.  
**ADVERTENCIA:** PELIGRO DE ATRAGANTAMIENTO. Juguete no recomendado  
para menores de 3 años, porque contiene piezas pequeñas que podrían  
provocar asfixia en caso de ser ingeridas o inhaladas por el/la niño/a.

**AVVERTENZA:** Contiene pezzi di piccole dimensioni.

**ACHTUNG:** Kleine Teile.

**OSTRZEŻENIE:** Małe części. Niebezpieczeństwo zadławienia.

**WAARSCHUWING:** Kleine onderdelen

**ПРЕДУПРЕЖДЕНИЕ:** Мелкие детали.

**ADVARSEL:** Indeholder små dele.

**VARNING:** Smådelar

**ADVARSEL:** Små deler

**VAROITUS:** Pieniä osia

**ΠΡΟΣΟΧΗ:** Περιλαμβάνονται μικρά κομμάτια.

**UYARI:** Küçük parçalar.

**UPOZORNĚNÍ:** Malé díly

**UPOZORNENIE:** Malé časti

**FIGYELMEZTETÉS:** Kis alkatrészek.



تحذير:

غير مناسب للأطفال دون 36 شهراً - قطع صغيرة.

\*HHP86, HHP87, HHP88, HHM01

Set(s) sold separately and subject to availability. / Ensemble(s) vendu(s) séparément.

Certains produits peuvent ne pas être commercialisés. / Se vende(n) por separado y está(n) sujeto(s) a disponibilidad. / Conjunto(s) vendido(s) em separado e sujeito(s) à disponibilidade. / Set in vendita separatamente, secondo disponibilità.

/ Das/Die Set(s) sind separat erhältlich. / Zestaw(y) sprzedawany(e) oddzielnie w zależności od dostępności. / Set(s) apart verkrijgbaar en afhankelijk van beschikbaarheid. / Набор(-ы) продаются отдельно, при наличии. / Sæt sælges separat og så længe lager haves. / Seten säljs separat så länge lagret räcker. / Settet/settene selges separat så langt lageret rekker. / Pakkaus/pakkaukset myydään erikseen, saatavuus voi vaihdella. / Το(α) σετ πωλούνται ξεχωριστά και ανάλογα με τη διαθεσιμότητα. / Setler ayrı olarak satılır ve stoklarla sınırlıdır. / Set (sety) se prodává (prodávají) samostatně dle aktuální nabídky. / Súprava/-y sa predáva(jú) samostatne a podľa dostupnosti. / A készlet(ek) külön kapható(k), az elérhetőség változhat. / セット商品は別売りになります。在庫状況は別途ご確認をお願いします。 / تبيع المجموعة على المجموعات علي حدة وتخضع لتوافرها. / 每套单独发售，供货情况决定。

Mattel Europa B.V., Gondel 1, 1186 MJ Amstelveen, Nederland. Mattel U.K. Limited, The Porter Building, 1 Brunel Way, Slough SL1 1FQ, UK. Mattel France, Parc de la Cerisaie, 1/3/5 allée des Fleurs, 94260 Fresnes Cedex. N° Cristal 0969 36 99 99 (Número non surtaxé) ou www.lesjointsmattel.fr Mattel Belgium, Trade Mart, Atomiumsquare, Bogota 202 - B 275, 1020 Brussels. Gratis nummer België: 0800 - 16 936 - Gratis nummer Luxembourg: 800 - 22 784 - Gratis nummer Nederland: 0800 - 262 88 35. Deutschland: Mattel GmbH, Solmsstraße 83, D-60486 Frankfurt am Main. Schweiz: Mattel AG, Kirchstrasse 24, CH-2097 Liebefeld. Österreich: Mattel Ges.m.b.H., Campus 21, Liebermannstraße A01 404, A- 2345 Brunn/ Gebirge. Mattel Italy Srl, Via Turati 4, 20121 Milano, Italy. Servizio assistenza clienti: CustomerServiceItaly@mattel.com. Numero verde 800 11 37 11. Mattel España, S.A., Aribau 200 pl. 9, 08036 Barcelona, cservice.spain@mattel.com Tel: +34 933 06 79 00 Italy. Servizio clienti: CustomerServiceItaly@mattel.com. Numero verde 800 11 37 11. Mattel East Asia Ltd., Room 503-09 North Tower, World Finance Centre, Harbour City, Tsimshatsui, HK, China. Tel: (852) 3185-6500. Diimport & Diedarkan Oleh: Mattel Continental Asia Sdn Bhd. Level 19, Tower 3, Avenue 7, No. 8 Jalan Kerinci, Bangsar South, 59200 Kuala Lumpur, Malaysia. Mattel South Africa (PTY) LTD, Office 102/13, 30 Melrose Boulevard, Johannesburg 2196. Distributor: Mattel Poland Sp. z o.o., Warsaw Trade Tower 34 p., ul. Chłodna 51, 00-867 Warszawa, Mattel Australia Pty. Ltd., 658 Church St., Richmond, Victoria, 3121. Consumer Advisory Service - 1300 135 312. Mattel AEBE, Εθνικού Μοκάρπου 1, Κτήριο Κ-2, ΤΚ 17561, Πλακάτο Όαγγο, Mattel Oyuncak Kaleleri Tic. Ltd. Şti. İkerenköy Mah., Umut Sok. No:10-12 Quick Tower Kat:2/15 34752. Ataşehir İstanbul Tel: 0216 570 75 00. Импортёр/Импортованная организация: ООО "МАТТЕЛ" Россия/Оук Калери, 105120 Москва, 2-й Суворовский перулок 1, +7 495 287 79 39. Mattel Czech Republic s.r.o., The Forum, Václavské nám. 19, 11000 Praha1. Mattel, 333 Continental Boulevard, El Segundo, CA 90245, USA. Consumer Services: 1-800-465-MEGA (6342). Mattel Canada Ltd., Mississauga, Ontario L5R 3W2. Consumer Services: You may call us free, le 1-800-524-8697. Importado y distribuido por Mattel de México, S.A. de C.V., Miguel de Cervantes Saavedra No. 193, Piso 10 y 11, Col. Granada, Alcaldía Miguel Hidalgo, C.P. 11520, México, Ciudad de México. R.F.C. MME-920701-N83. Tel: 59-05-51-00 Ext. 5206 6-01-800-463-59-89. Mattel Chile, S.A., Avenida Américo Vesputcio 501-B, Quilicura, Santiago, Chile. Tel: 1230-020-6213. Servicio al consumidor Venezuela: Tel: 0-800-100-9123. Mattel Argentina, S.A., Av. Libertador 1000, Piso 11 - Oficinas 109 y 111, Vicente López - Prov. Buenos Aires. Tel: 0800-666-3373. Mattel Colombia, S.A., Calle 123#47-07 P.5, Bogotá. Tel: 01-800-710-2069. Mattel Perú, S.A., Av. Juan de Arona # 151, Centro Empresarial Juan de Arona, Torre C, Pw7, Oficina 704, San Isidro, Lima 27, Perú. RUC: 20425853865. Reg. Importador: 02350-12-JUE-DIGESA. Tel: 0800-54744. E-mail Latinoamérica: Atendimento a consumidor@mattel.com. Mattel do Brasil Ltda., CNPJ: 54.558.002/0001-20 - Rua Verbo Divino, 1488 - 2º - Andar - 04719-904 - Chácara Santo Antônio - São Paulo - SP - Brasil. Serviço de Atendimento ao Consumidor: fone 0800 575 0780. E-mail: sac.matteldobrazil@mattel.com



\*HHP86



\*HHP87



\*HHP88



\*HHM01

# DISCOVER, DELIGHT AND DREAM WITH MEGA™ BARBIE® COLOR REVEAL! UN MONDE DE DÉCOUVERTES, DE PLAISIRS ET DE RÊVES VOUS ATTEND AVEC BARBIE® COLOR REVEAL



¡DESCUBRE, DISFRUTA Y SUEÑA CON BARBIE® COLOR REVEAL DE MEGA™!  
DESCUBRA, SONHE E DELICIE-SE COM A BARBIE® COLOR REVEAL DA MEGA™  
ENTDECKEN, FREUEN UND TRÄUMEN MIT MEGA BARBIE COLOR REVEAL!  
ОТКРЫВАЙТЕ НОВЫЙ МИР, РАДУЙТЕСЬ И МЕЧТАЙТЕ С НАБОРОМ MEGA™ BARBIE® COLOR REVEAL!

BARBIE® and associated trademarks and trade dress are owned by,  
and used under license from Mattel. ©2022 Mattel.

©2022 MEGA Brands &™ MEGA Brands.

Printed in China / Imprimé en Chine

AD-HHW83-01B

Mattel Canada Inc. Mississauga, Ontario L5R 3W2.  
MADE IN CHINA. FABRIQUÉ EN CHINE. FABRICADO NA CHINA. HECHO EN CHINA.  
ИЗГОТОВЛЕНО В КИТАЕ. ÇIN'DE ÜRETİLMİŞTİR. صنع في الصين



1186 MJ, 1, NL

