

\*Instructions included for main model only. Other build(s) can be found at [megaunboxed.com](http://megaunboxed.com) / Instructions incluses pour le modèle principal uniquement. Les instructions pour l'(les) autre(s) modèle(s) de construction se trouvent sur le site [megaunboxed.com](http://megaunboxed.com)



# HALO

# 2 IN 1<sup>\*</sup>

EM / B



GYG59

## UNSC RAZORBACK BLITZ ATTAQUE UNSC RAZORBACK

BOMBARDEO UNSC RAZORBAC  
OFENSIVA RAZORBACK UNSC / ТАНКОВАЯ АТАКА

# HALO INFINITE





**Build**  
**Construisez**  
Construye | Constrói  
Bauen | Стройте



**Share | Partagez**  
Comparte | Partilha  
Teilen | Делитесь

Devices not included | Appareils non inclus | Dispositivos no incluido  
Dispositivos não incluídos | Geräte nicht enthalten | Устройства не входят в комплект

**Get the 2-in-1 rebuild steps!**  
**Accédez aux instructions**  
**de reconstruction des jouets 2-en-1 !**

¡Consigue los pasos de reconstrucción 2 en 1! Obtém os passos de reconstrução 2 em 1! Jetzt die 2-in-1-Schritte für die zweite Baumöglichkeit entdecken! | Получите инструкции по сборке игрушки 2-в-1!



Most models can be built one at a time. / La plupart des modèles peuvent être construits un à la fois. / La mayoría de modelos se pueden construir de uno en uno. A maioria dos modelos pode ser construída separadamente. / La maggior parte dei modelli possono essere realizzati uno per volta. / Die meisten Modelle können eines nach dem anderen gebaut werden. / Większości modeli nie da się budować jednocześnie z innymi. / De meeste modellen kunnen één voor één gebouwd worden. / Большинство моделей могут быть собраны по одной за раз. / De fleste modeller kan bygges enkeltvis. / De flesta modeller kan byggas en i taget. De fleste modellene kan bygges en om gangen. / Useimmat mallit voidaan rakentaa yksi kerrallaan. / Τα περισσότερα μοντέλα μπορούν να κατασκευασθούν ένα ένα. / Modellerein çoğu ayrı ayrı inşa edilmeyi gerektirebilir. / Většinou lze najednou sestavit pouze jeden model. / Väčšina modelov môže byť zostavená iba raz. / A modellek többségéből egyszerre csak egy építhető. /ほとんどのモデルは、一度に一つを組み立てることができます。

يمكن تركيب التصميم الواحد تلو الآخر.

**大多數型號可一次性建構**

[megaunboxed.com](http://megaunboxed.com)





# BUILDING TOOL OUTIL DE CONSTRUCTION

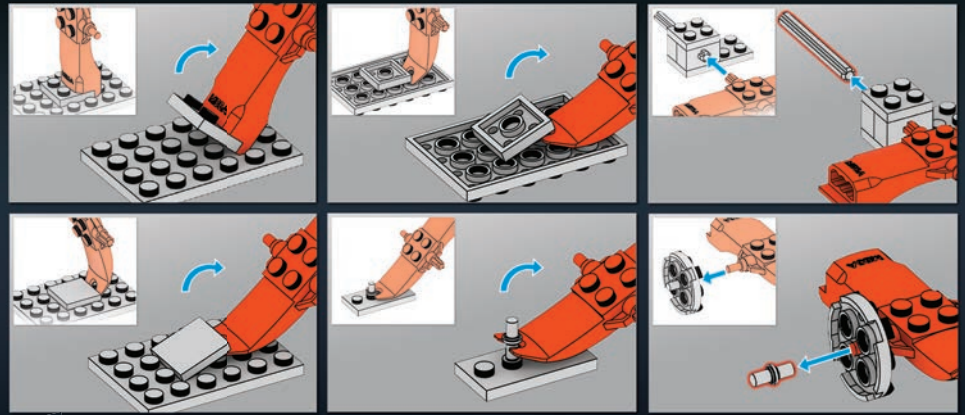

HERRAMIENTA DE CONSTRUCCIÓN / BAUWERKZEUG / FERRAMENTA DE MONTAGEM / ИНСТРУМЕНТ ДЛЯ КОНСТРУИРОВАНИЯ



1

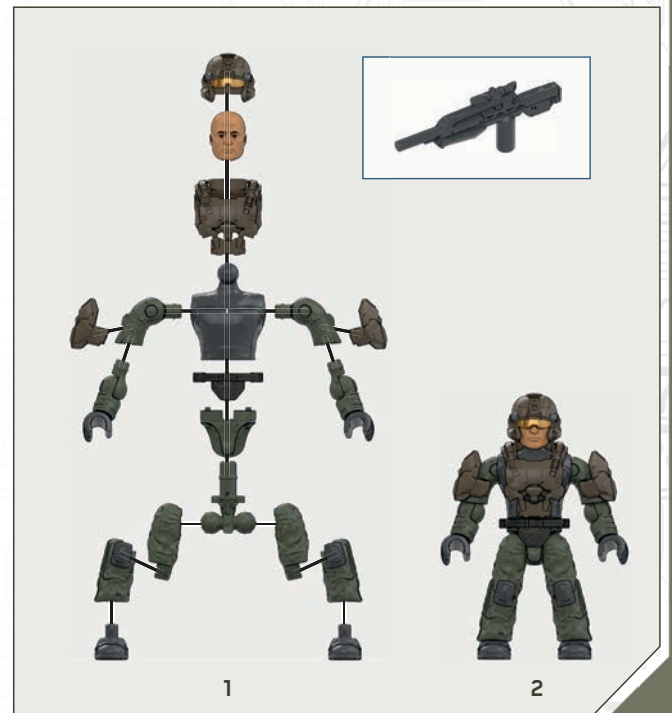
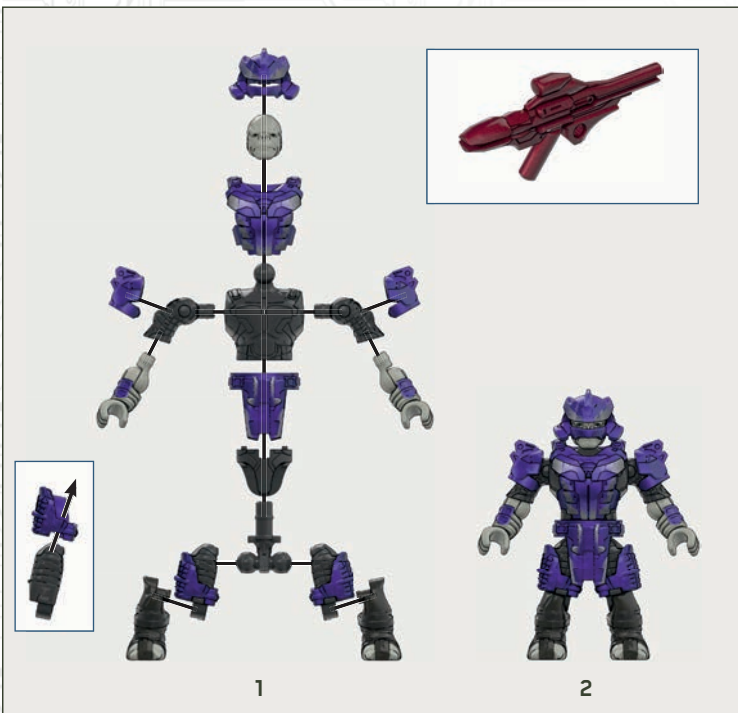





1



2



1



2

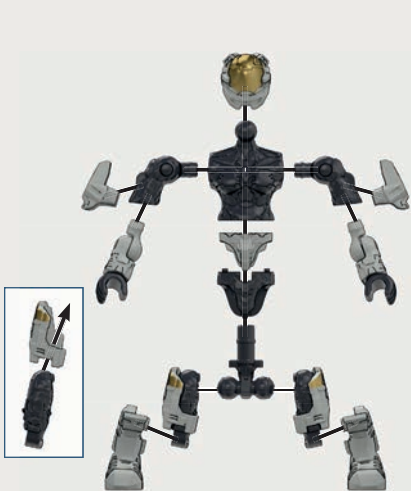
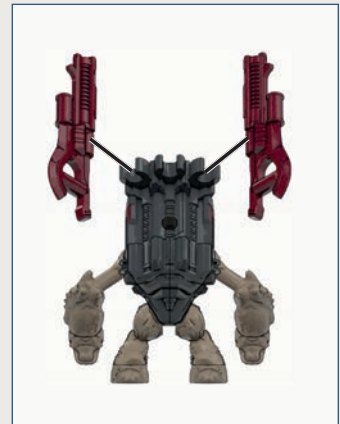

1

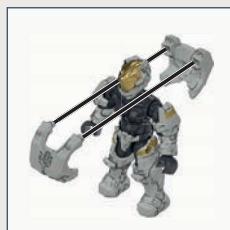

2







**2**

2X      1X

**3**

4X

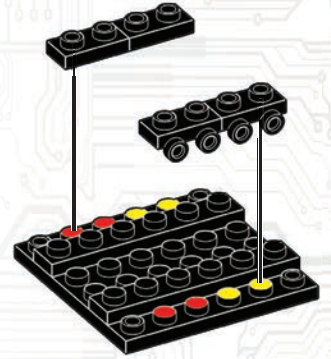
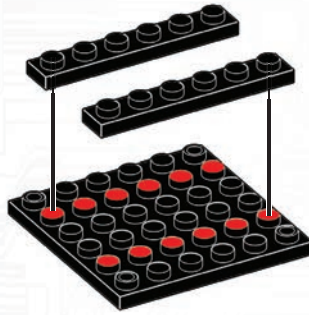

**4**

4X

**5**

4X      4X

**x4**

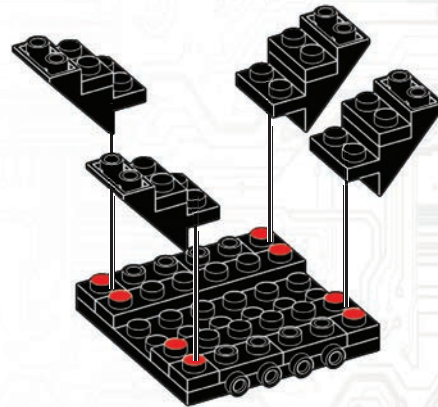
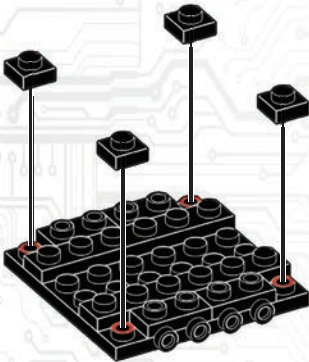

6

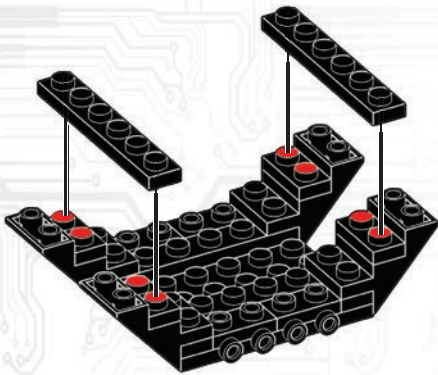

7

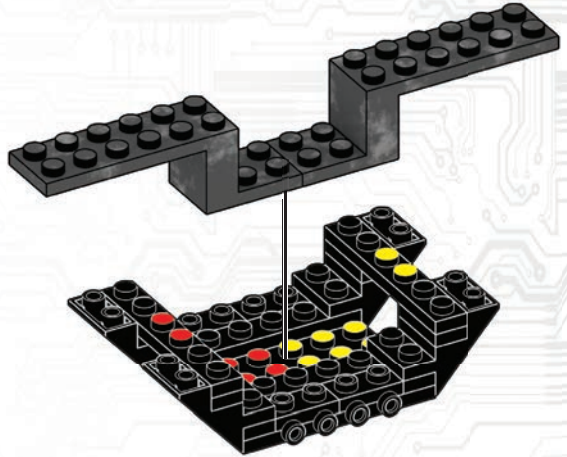
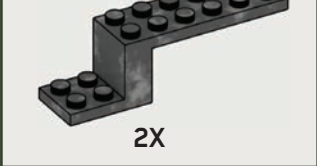

8

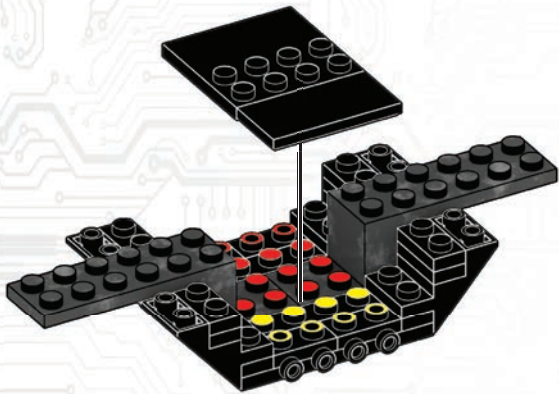
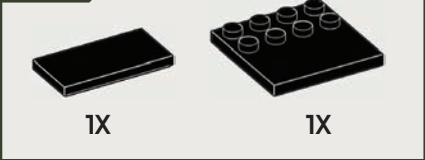

1

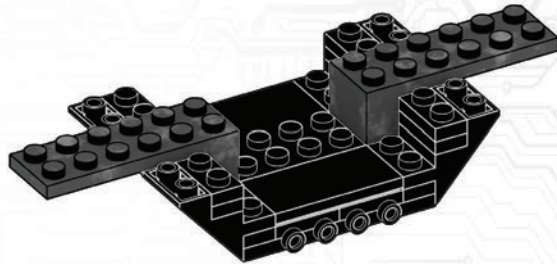

2



9

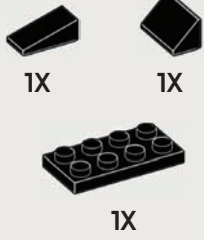

10

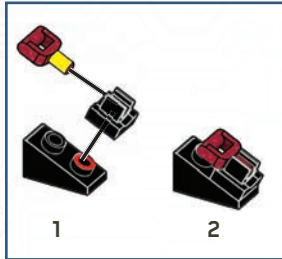

11



12

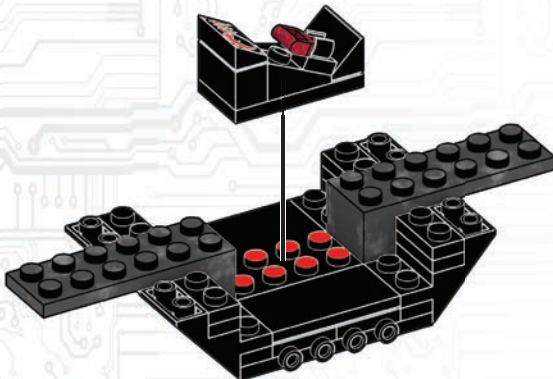

13

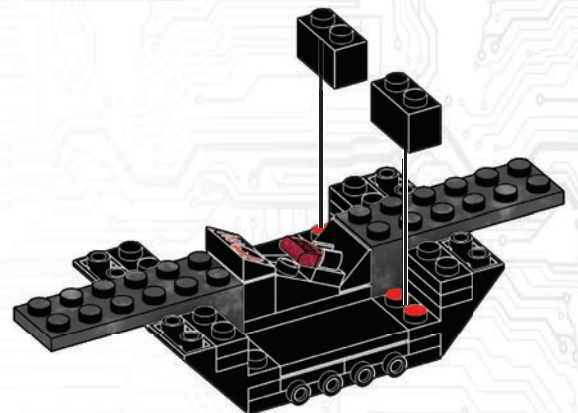

14



1X



2X



1X



Place temporary pieces. / Placer les pièces temporaires.  
 / Colocar las piezas provisionales. / Colocar as peças temporárias. / Posizionare i pezzi provvisori. / Die vorübergehend benötigten Teile platzieren. / Umieść tymczasowe elementy. / Plaats tijdelijke delen. / Поместите временные детали. / Placer midlertidige stykker. / Placera temporära delar. / Placser midlertidige deler. / Aseta väliaikaiset osat. / Τοποθετήστε το προσωρινό κομμάτι. / Geçici parçaları yerleştirin. / Umístěte dočasné díly. / Vložte dočasné kusy. / Helyezze el az ideiglenes darabokat. / 暫定ピースを配置してください / وضع القطع المؤقت

放置临时件

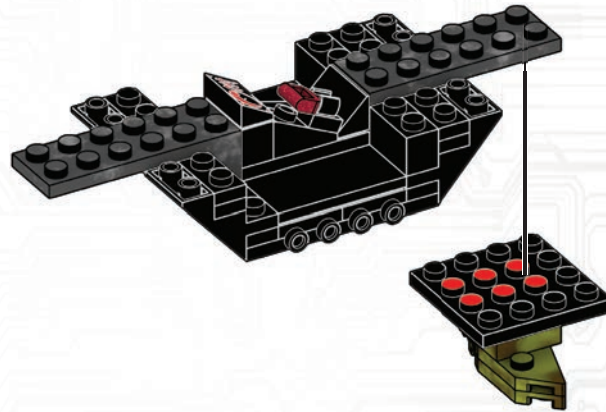
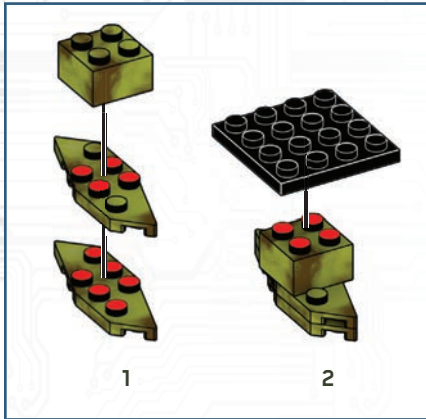

15



2X

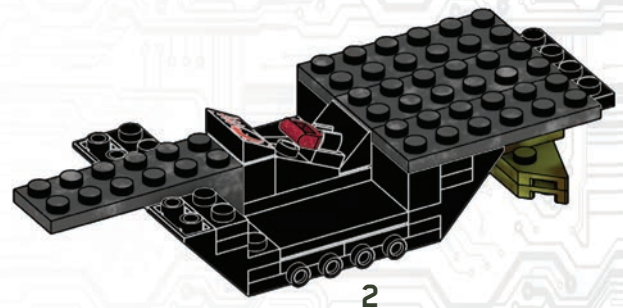
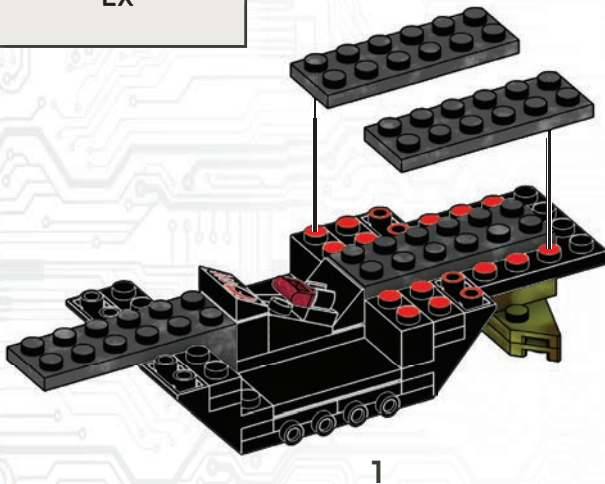



16

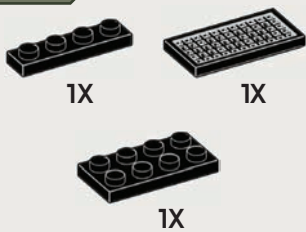

17

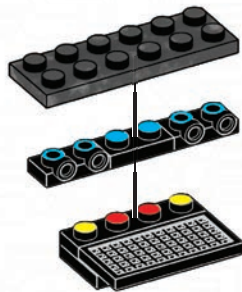
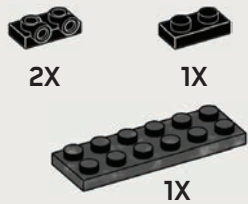

18

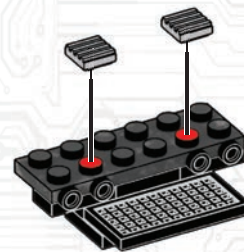

19

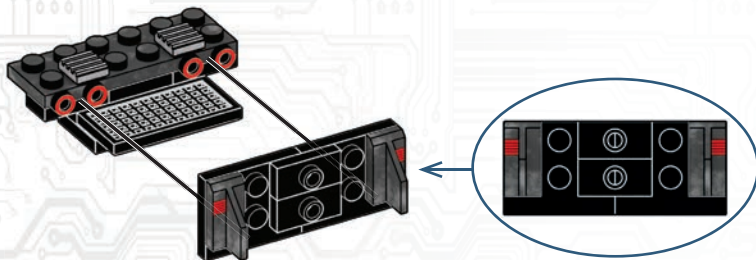
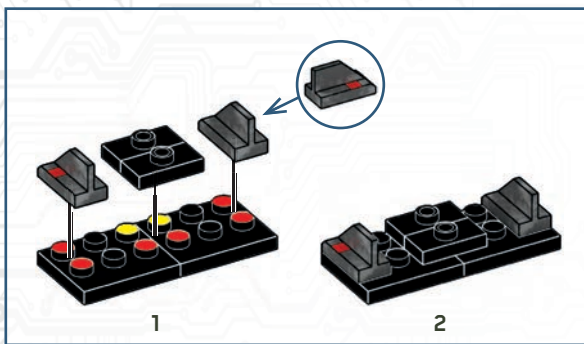
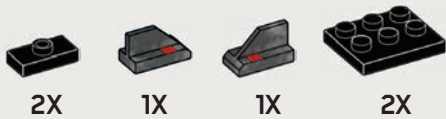

20

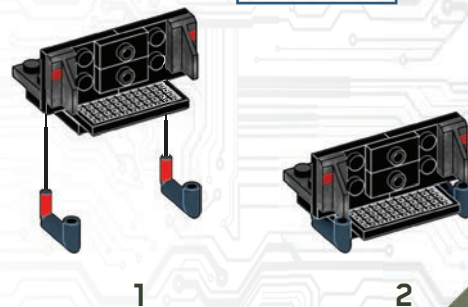
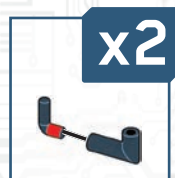
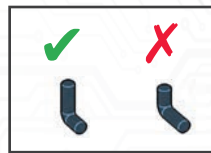

21

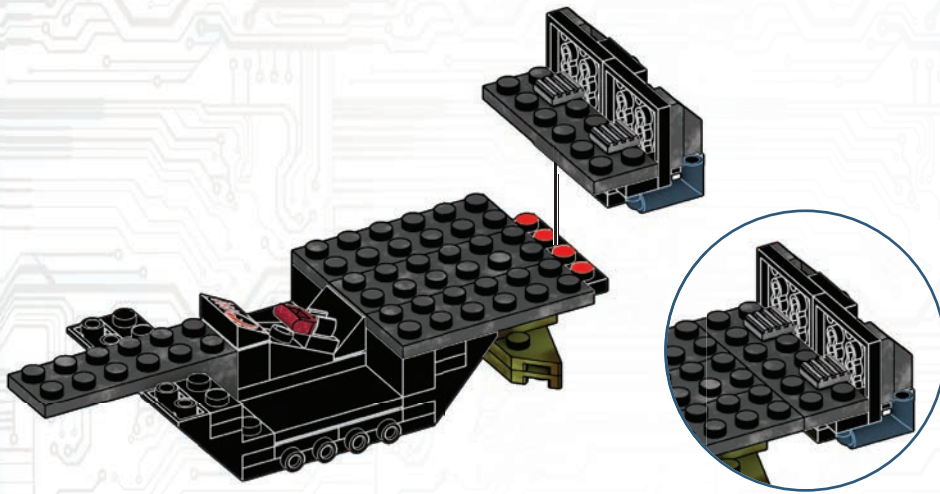

22

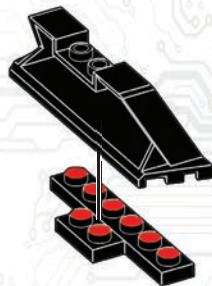
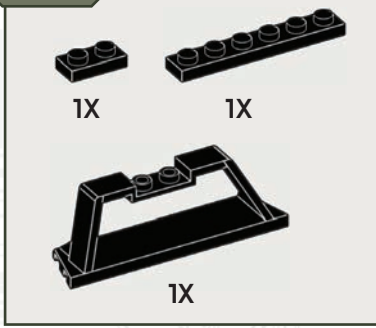

23

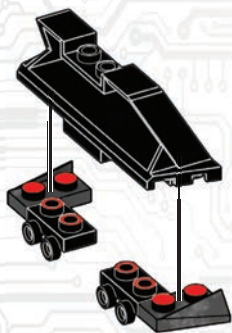
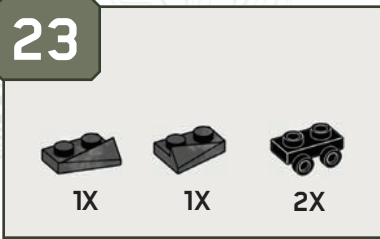

24

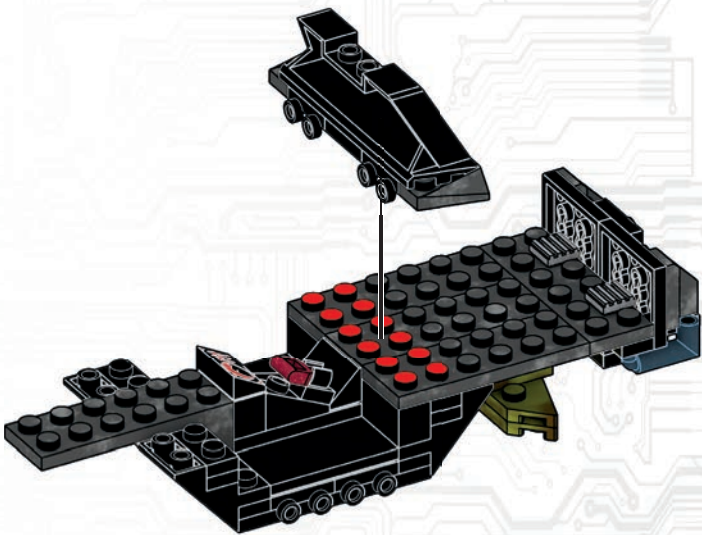



25



2X



2X

x2

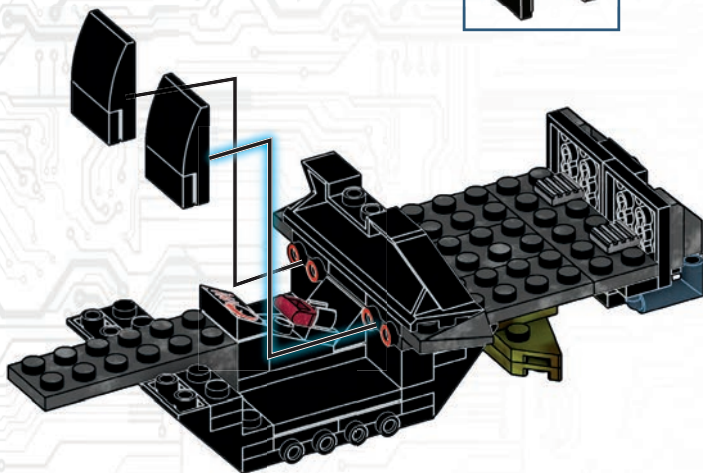

1

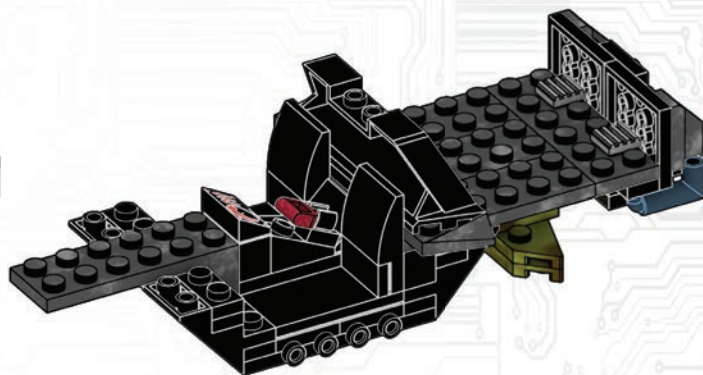

2



26



1X



1X



1X



1X



1X

27



1X



1X

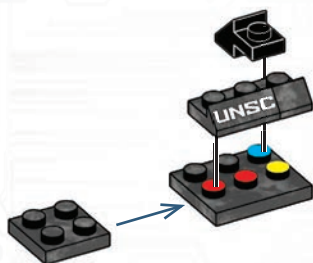

28



1X

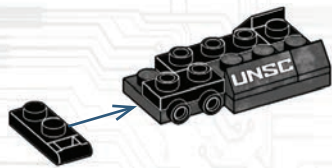

29



1X



1X



30



1X



1X



31



1X



1X



1



2

32

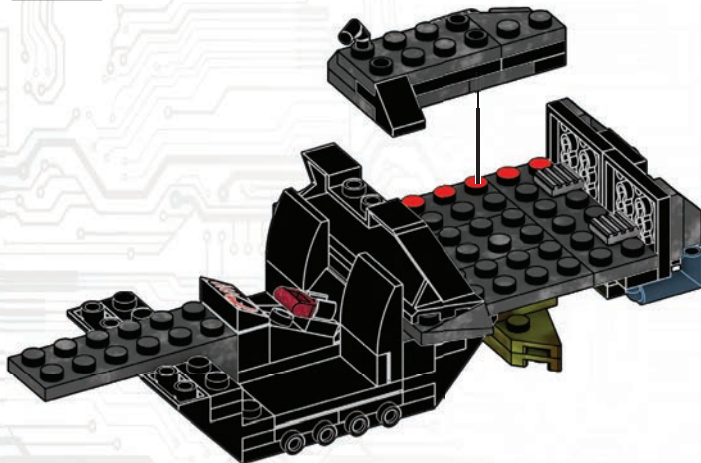

1

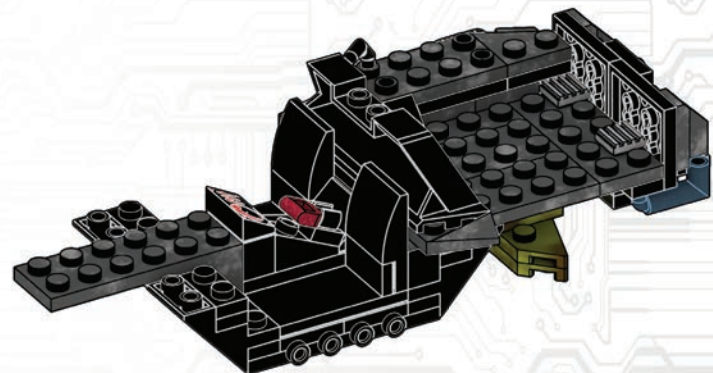

2



33



34



35



36



37



38



1



2

39

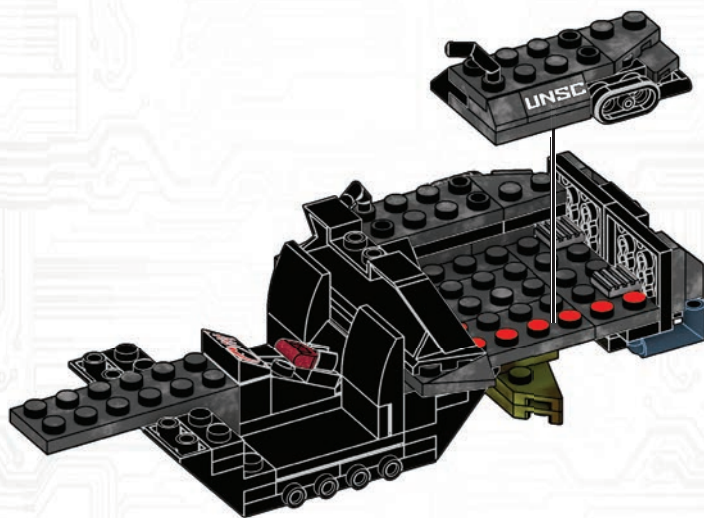

40



2X

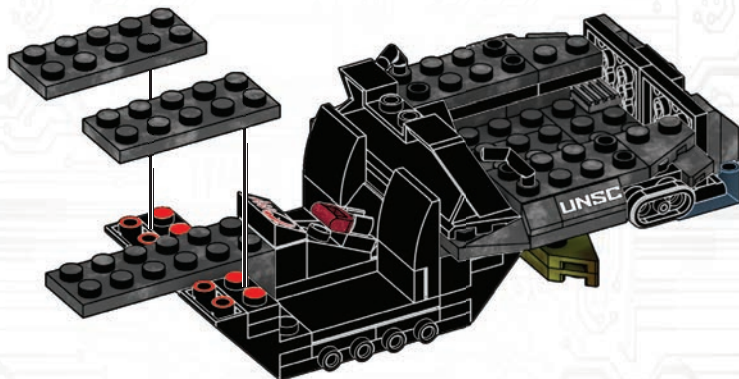



41



1X



2X



1X

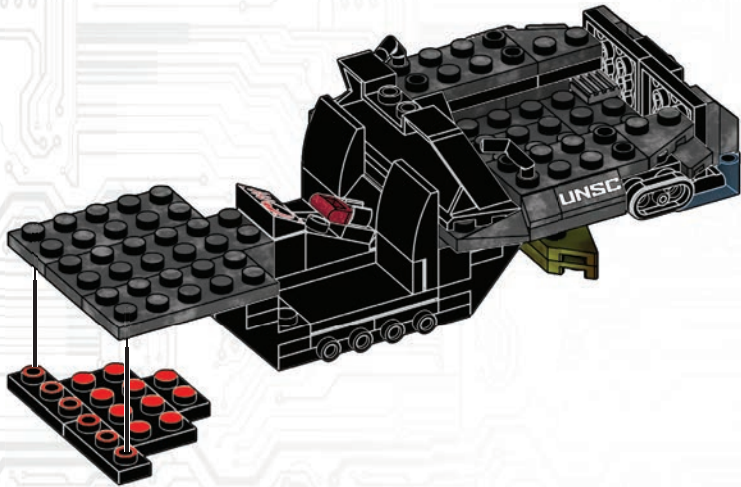
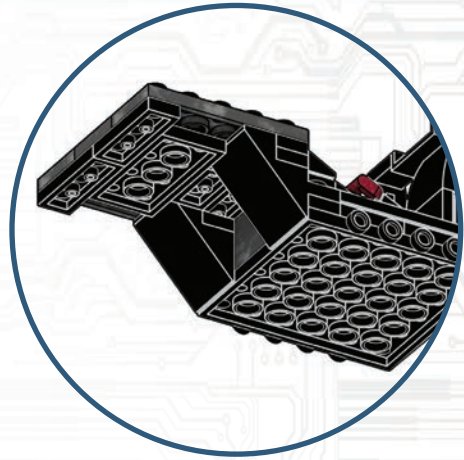

42



2X



2X



1



2



1



2

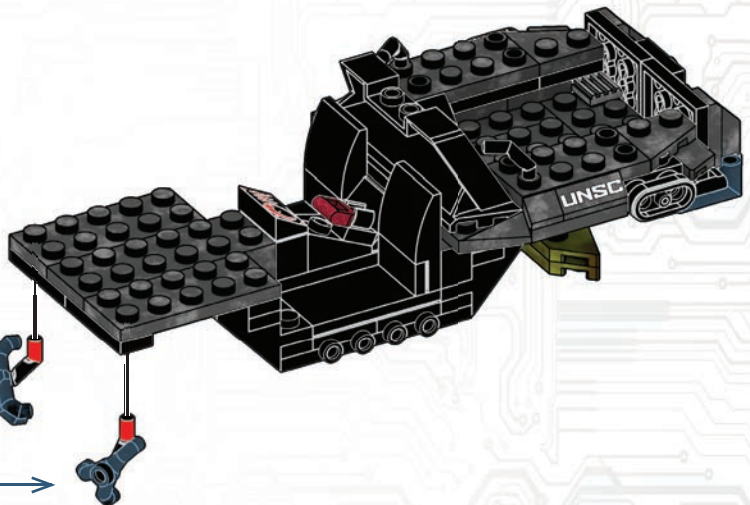

43



1X



2X



1



2

Place temporary pieces.  
 Placer les pièces temporaires.  
 Colocar las piezas provisionales.  
 Colocar as peças temporárias.  
 Posizionare i pezzi provvisori.  
 Die vorübergehend benötigten Teile platzieren.  
 Umieścić tymczasowe elementy.  
 Plaats tijdelijke delen.  
 Поместите временные детали.  
 Placer midlertidige stykker.  
 Placera temporära delar.  
 Plasser midlertidige deler.  
 Aseta väliaikaiset osat.  
 Τοποθετήστε το προσωρινό κομμάτι.  
 Geçici parçaları yerleştirin.  
 Umístěte dočasné díly.  
 Vložte dočasné kusy.  
 Helyezze el az ideiglenes darabokat.  
 暫定ピースを配置してください

ضع القطع المؤقتة  
**放置临时件**

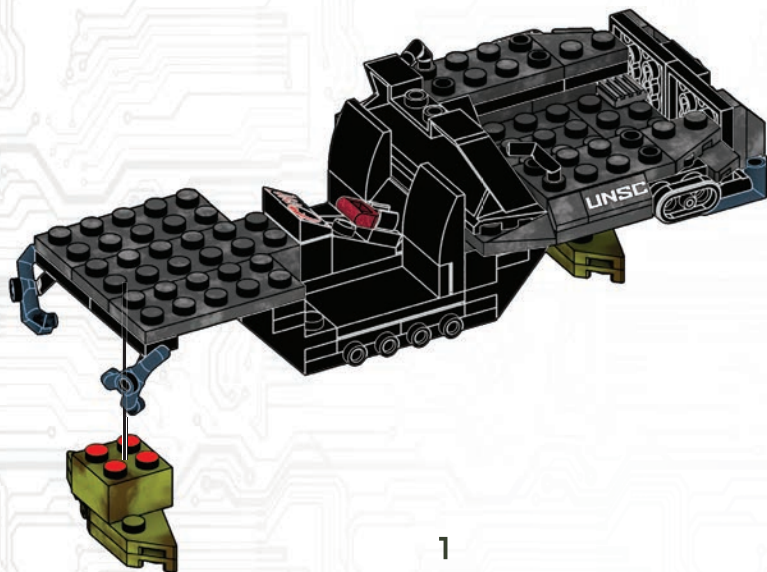

1

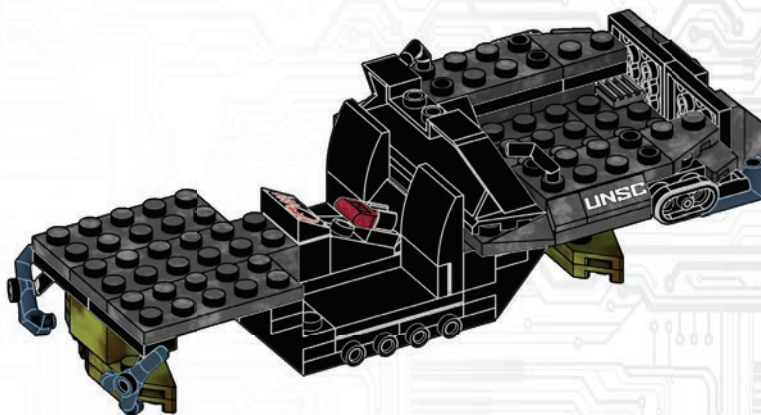

2



44



1X



2X

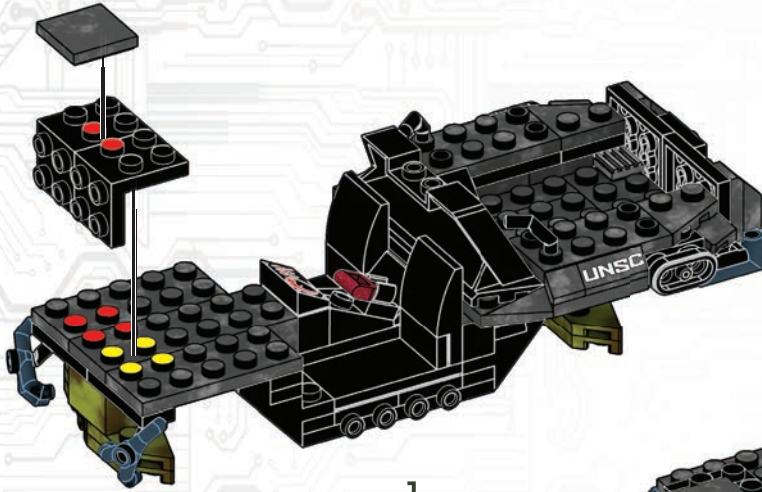

1

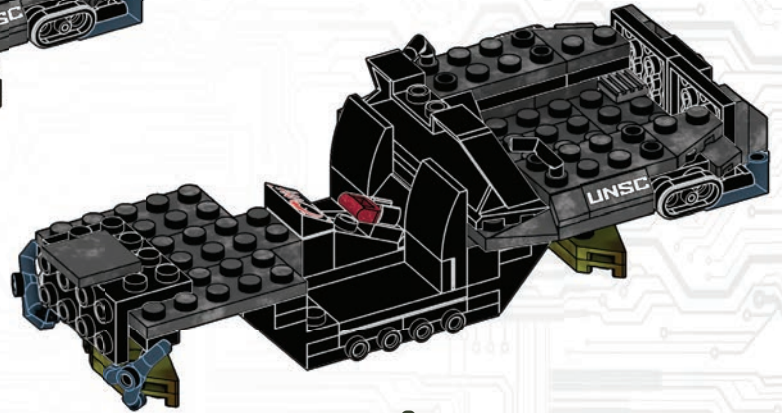

2

45



1X



1X



1X

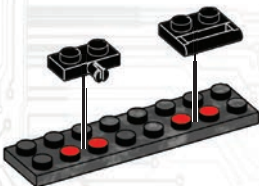

46



2X



1X

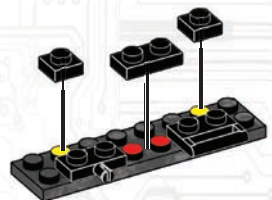

47



1X



2X

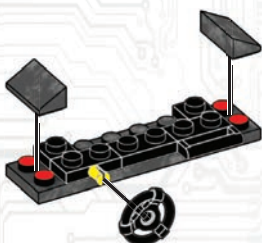

1

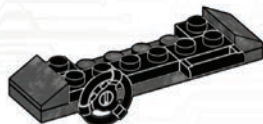

2

48

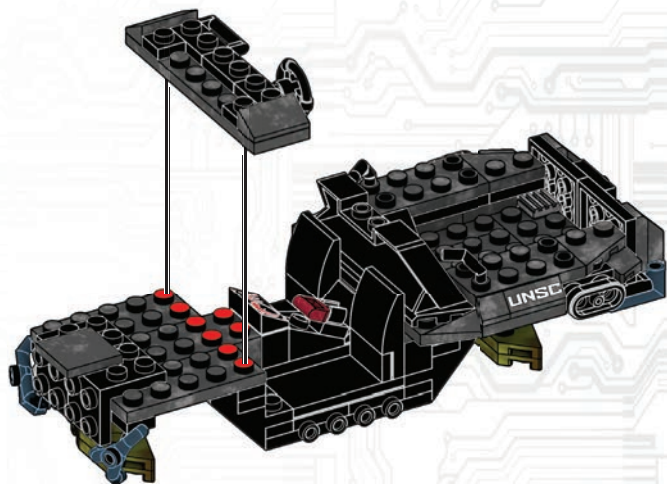

49



1X



1X

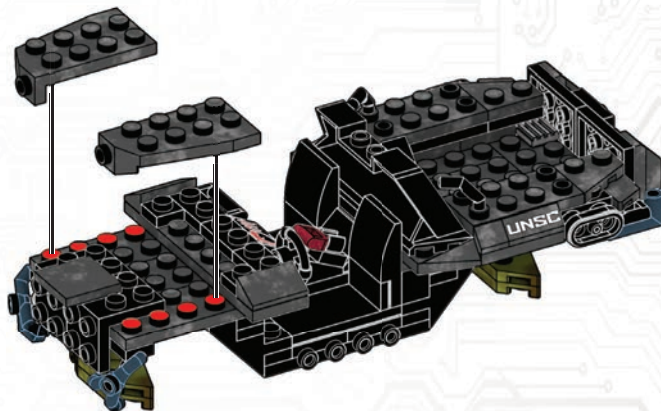



50



1X

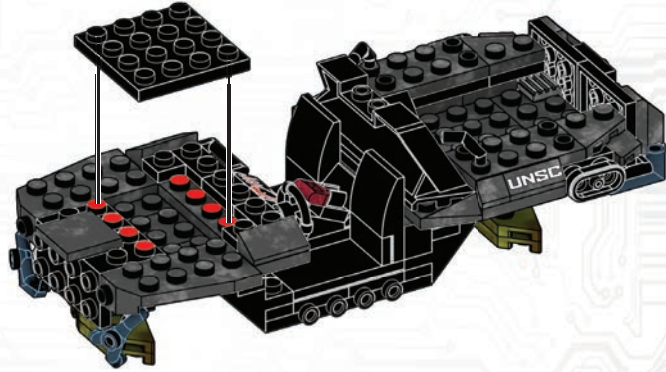

51



1X



1X

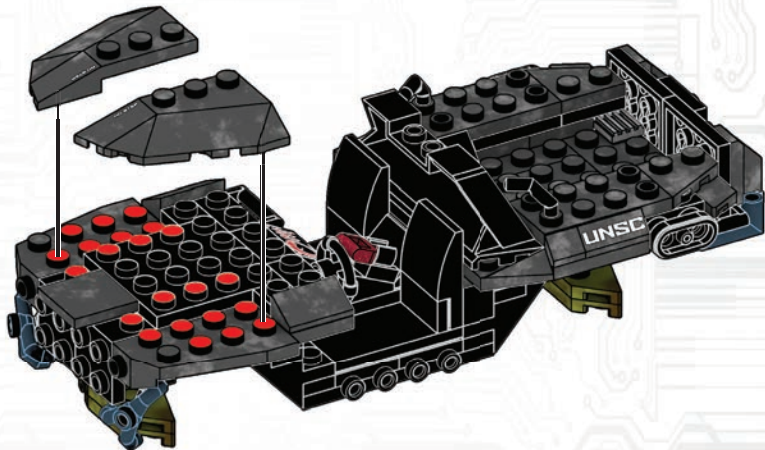

52



1X



1X

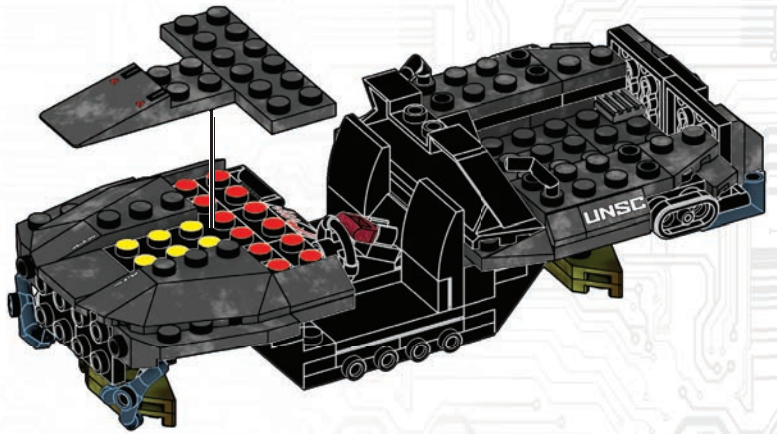

53



2X



1X



1X



1X



1



2

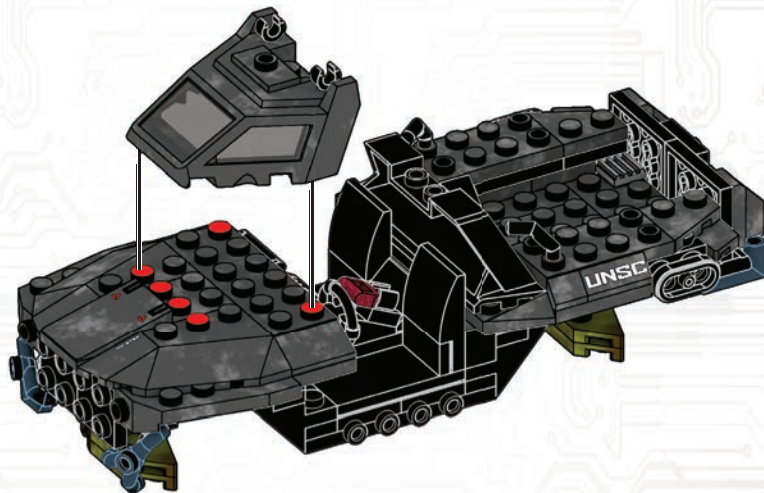





**54**

1X    1X    1X

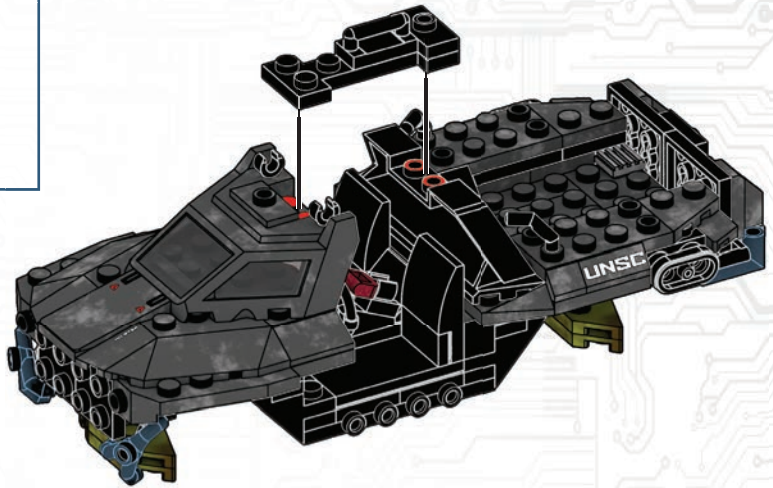

**55**

1X    1X

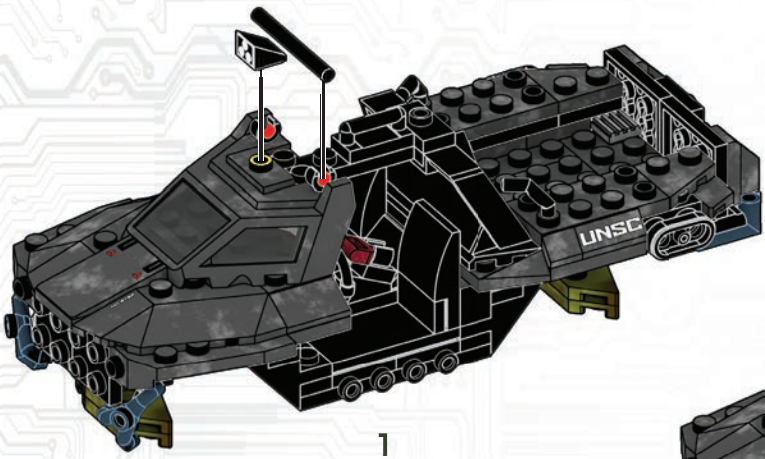

1

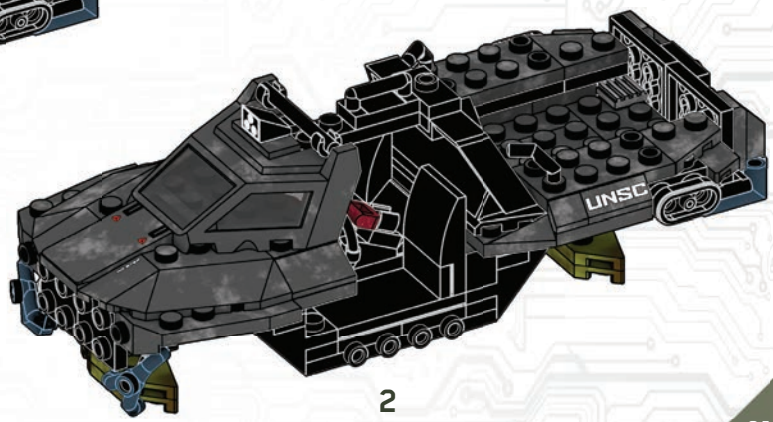

2

56



2X



1X



1X



1



2



3



4

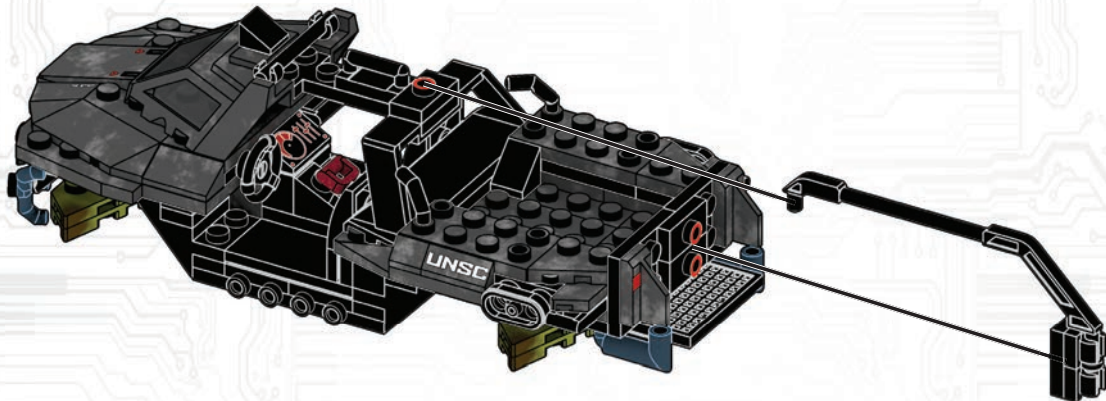

1

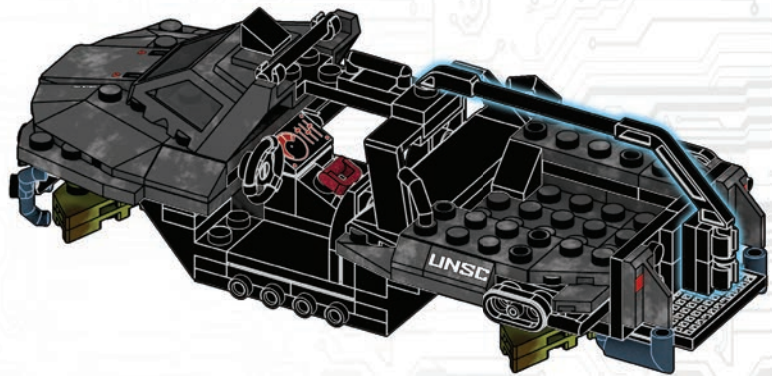

2



57

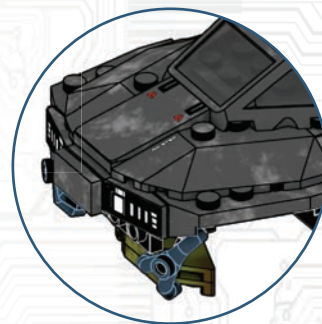
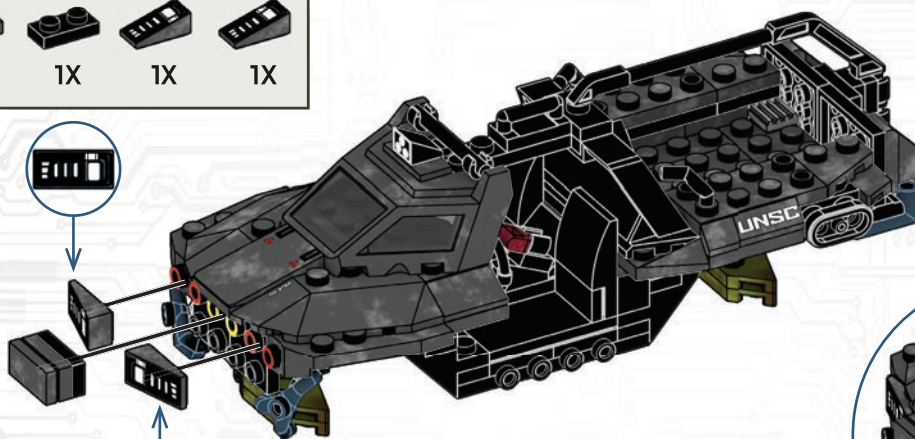

x2

58

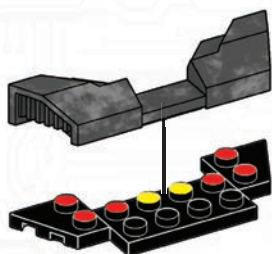
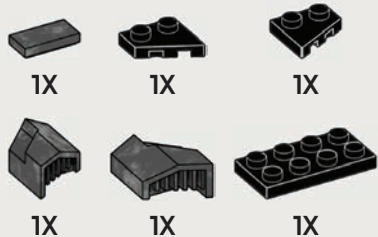

59

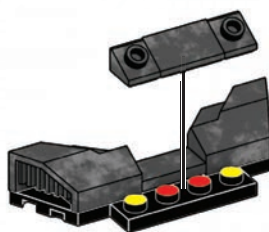

60



61

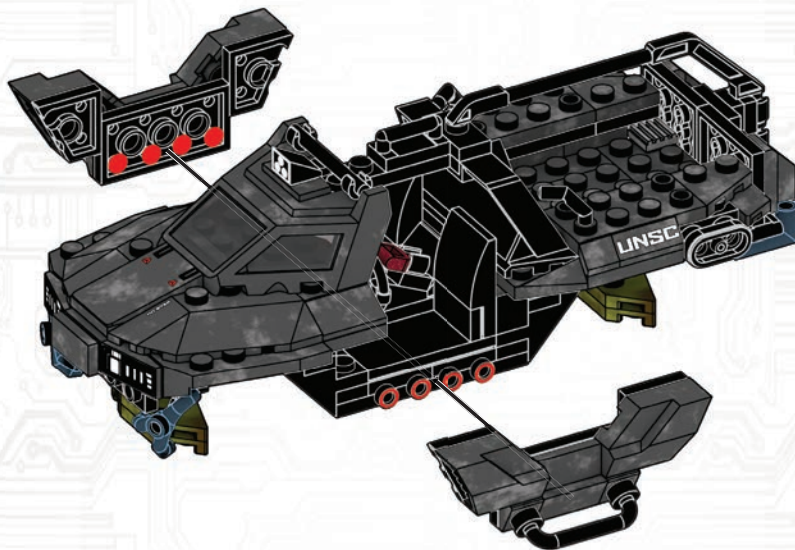

62



Remove temporary pieces.  
 Retirer les pièces temporaires.  
 Retirar las piezas provisionales.  
 Remover as peças temporárias.  
 Rimuovere i pezzi provvisori.  
 Die vorübergehend benötigten Teile entfernen.  
 Usunąć elementy tymczasowe.  
 Verwijder tijdelijke delen.  
 Удалите временные детали.  
 Fjern midlertidige stykker.  
 Ta bort temporära delar.  
 Fjern midlertidige deler.  
 Poista väliaikaiset osat.  
 Αφαιρέστε τα προσωρινά κομμάτια.  
 Geçici parçaları çıkarın.  
 Odstraňte dočasné diely.  
 Vyberte dočasné kusy.  
 Távolítsa el az ideiglenes darabokat.  
 暫定ピースを外してください

انزع القطع المؤقتة

移除临时件

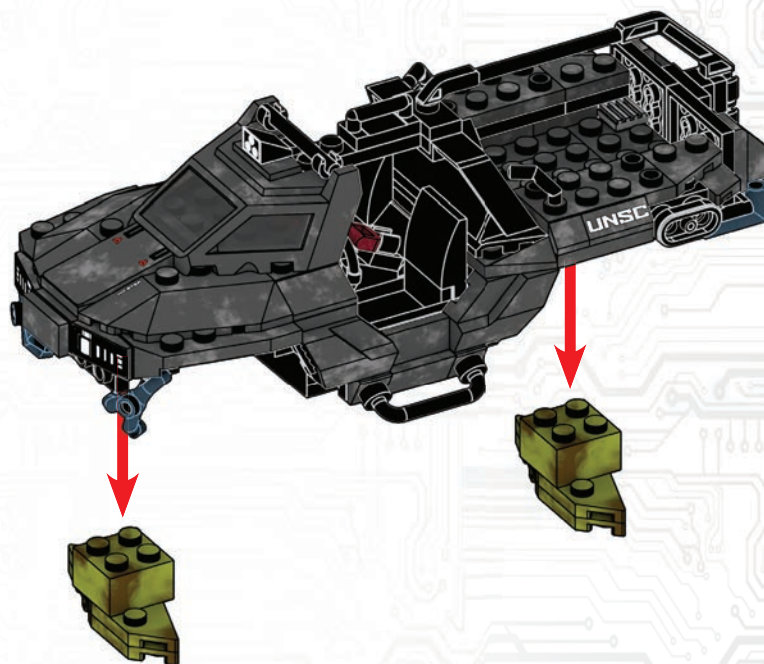



63



64

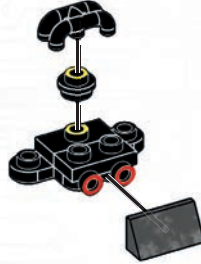

65

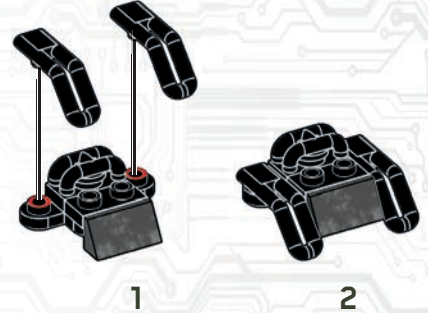

66

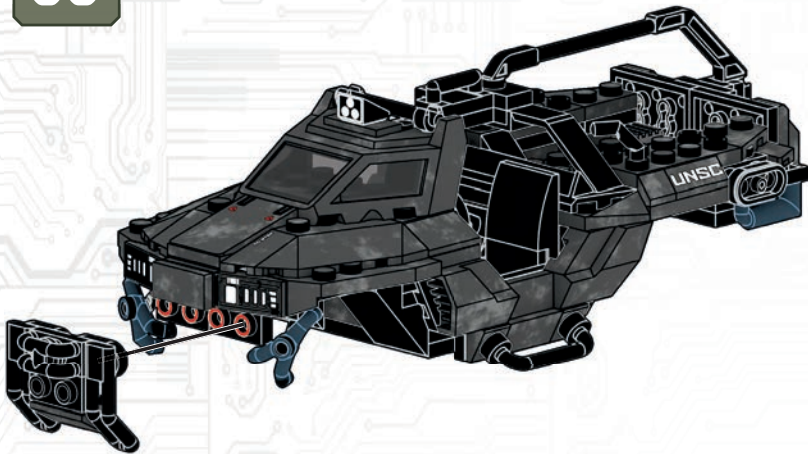

x2

67



4X

1X

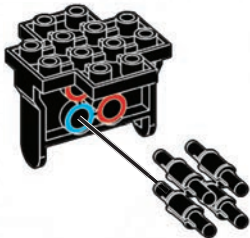

68



4X

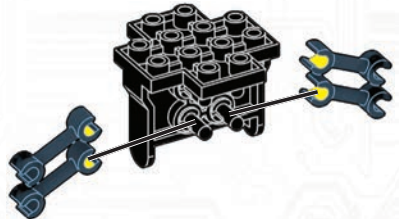

69



4X



2X

x2



1

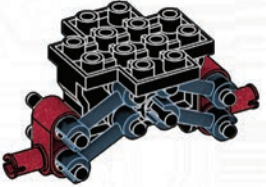

2

70



1X

71



4X

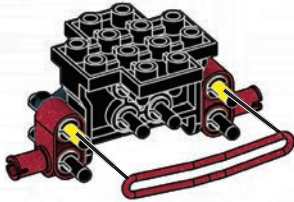

1

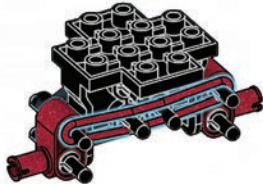

2

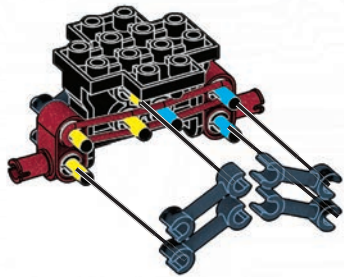

1

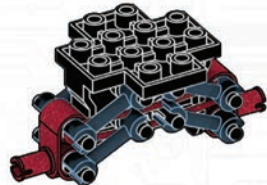

2



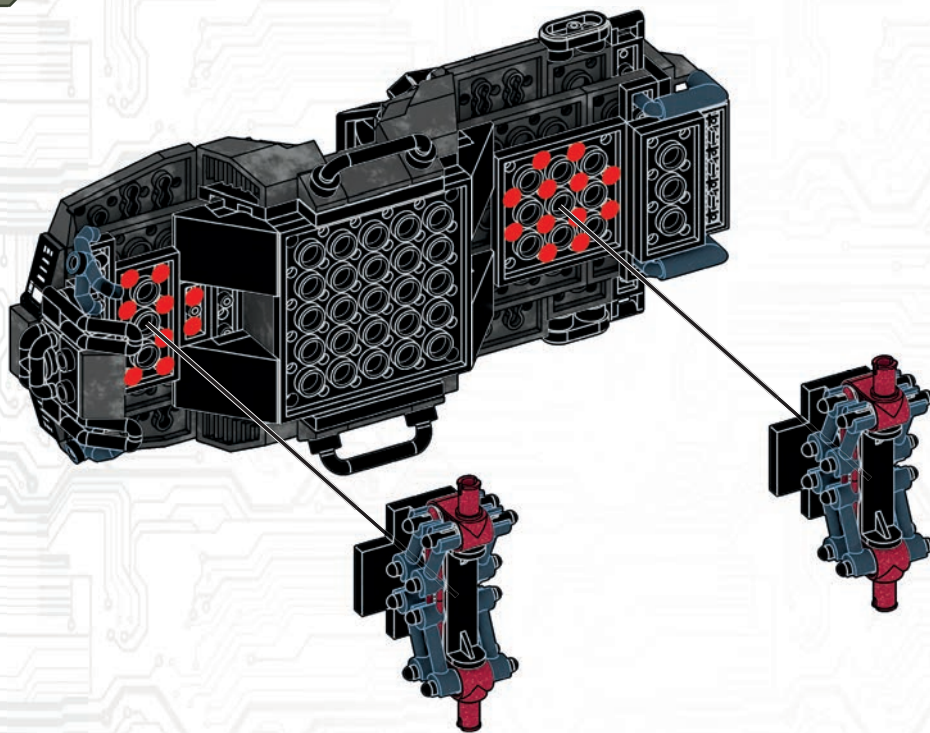

1

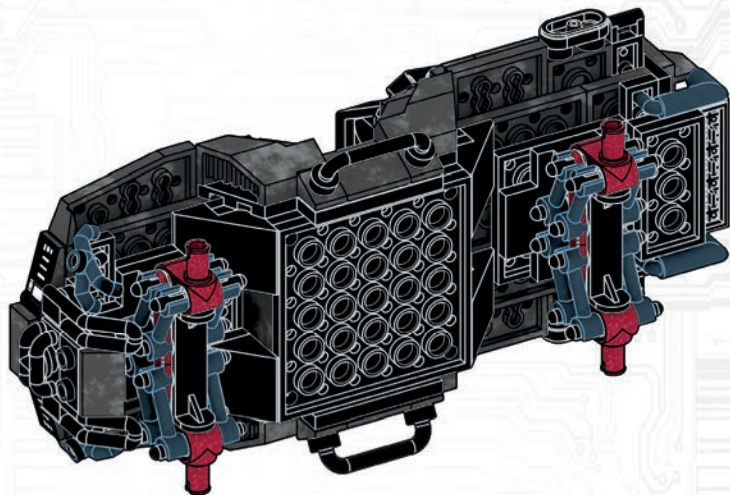

2

73



2X



2X

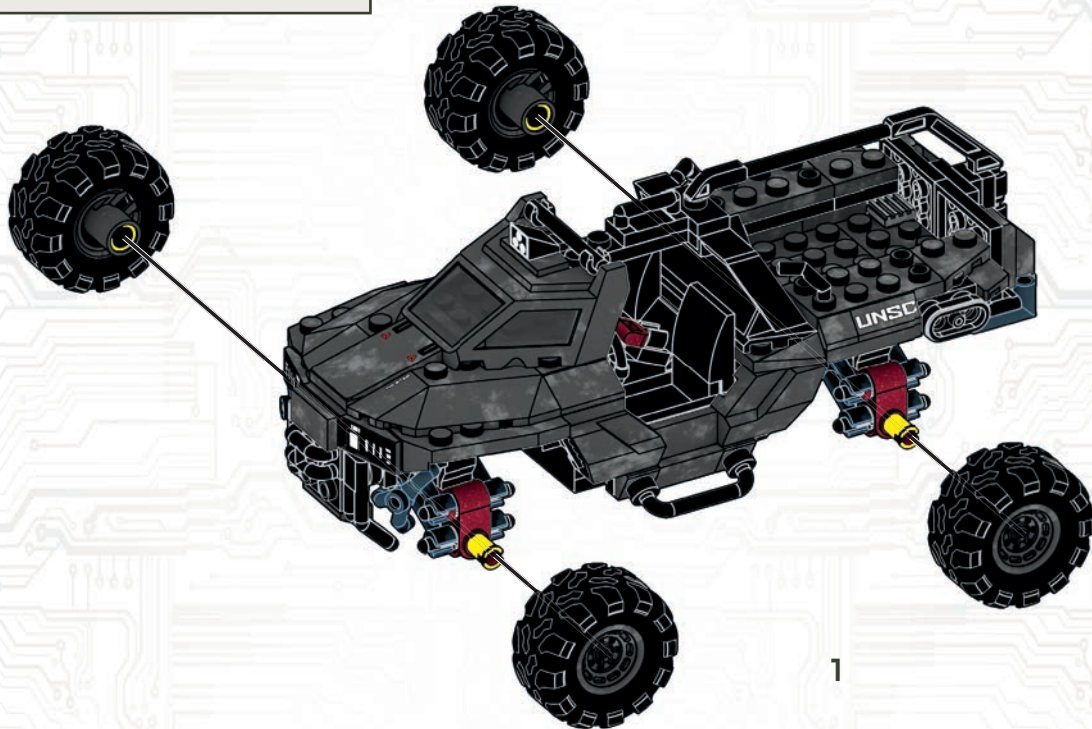

1

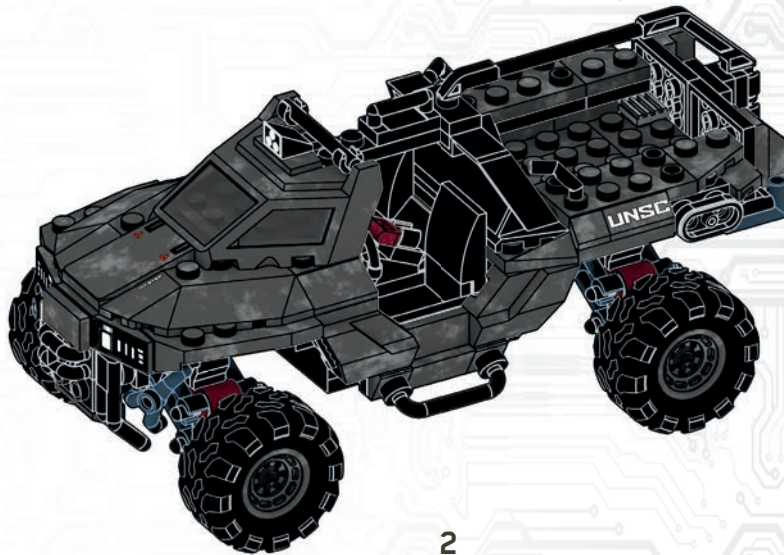

2



**ACTIVE SUSPENSION / SUSPENSION ACTIVE**

SUSPENSIÓN ACTIVA • SUSPENSÃO ATIVA  
BEWEGLICHE FEDERUNG • АКТИВНАЯ ПОДВЕСКА



**GRUNT MULE**



**UNSC MARINE**



**BRUTE WARRIOR**



**SPARTAN KELLY-087**



UNSC RAZORBACK BLITZ / ATTAQUE UNSC RAZORBACK  
BOMBARDEO UNSC RAZORBACK / OFENSIVA RAZORBACK UNSC  
BLITZ UNSC RAZORBACK / UNSC RAZORBACK BŁYSKAWICZNY ATAK ZESTAW / ТАНКОВАЯ АТАКА / UNSC RAZORBACK ROHAM  
NÁJEZD UNSC RAZORBACK / هجوم UNSC RAZORBACK BLITZ

2x  
AM17062F

1x  
AM18560F

6x  
AM03328F

2x  
AM79666APG

1x  
AS-GYG59-03

2x  
AM19392ALH

4x  
AM72001AJL

3x  
AM19999F

4x  
AM76052F

1x  
AM76060AKM

1x  
AM74299AJL

1x  
AM74300AJL

2x  
AM19530AJL

2x  
AM74645ALH

3x  
AM022501AJL

2x  
AM022501F

1x  
AM07590AJL

4x  
AM07590F

1x  
AM18221F

12x  
AM09393F

1x  
AM09393AJL

2x  
AM79070F

9x  
AM76467F

2x  
AM16649F

1x  
AM77573F

1x  
AM15480AJL

1x  
AM15481AJL

1x  
AS-GYG59-01

1x  
AS-GYG59-02

1x  
AM17128F

2x  
AM18740F

1x  
AM18559F

1x  
AM18665AJL

2x  
AM18665F

1x  
AM18666AJL

2x  
AM18666F

1x  
AS-GYG59-10

1x  
AS-GYG59-09

1x  
AS-GYG59-04

5x  
AM18549AJL

1x  
AM03019F

1x  
AM04429F

3x  
AM09013F

2x  
AM16972F

2x  
AM16954F

2x  
AS-GYG59-05

1x  
AM72000F

1x  
AM0948AJL

2x  
AM03773AJL

2x  
AM09023AJM

16x  
AM77492F

2x  
AM79721AKM

16x  
AM76653ALH

2x  
AM79424ALH

1x  
AM18220F

4x  
AM80745AKM

4x  
AM72600F

2x  
AM09931F

2x  
AM77747F

1x  
AM76521F

2x  
AM19012F

2x  
AM74139AJL

2x  
AM74139F

1x  
AM09593F

2x  
AM01141F

2x  
AM73900AJL

2x  
AM73901AJL

4x  
AM18230F

1x  
AM18276F

2x  
AM79019AJL

5x  
AM09493F

1x  
AS-GYG59-06

1x  
AM17148F

1x  
AM77463F

4x  
AM76357AJM

1x  
AM81228AJL

1x  
AM81227AJL

2x  
AM80965AJL

4x  
AM01480AJL

1x  
AS-GYG59-08

1x  
AS-GYG59-07

1x  
AM18617F

2x  
AM17054F

1x  
AM81225AGY

1x  
AM81226AJL

1x  
AM18218F

5x  
AM09292F

1x  
AM08483AJL

2x  
AM80747AJL

1x  
AM80855MCX





2x  
AM80746F



2x  
AS-GYG59-11



2x  
AS-GYG59-12



1x  
AM74681F



1x  
AM81229F



1x  
FIG-GYG59-A



1x  
FIG-GYG59-B



1x  
FIG-GYG59-C



1x  
FIG-GYG59-D



1x  
AM17622AYB



1x  
AM74941MM



1x  
AM75907AKM



1x  
AM18167AKM



1x  
AM19981AKM



2x  
AM80852AKM

### Missing pieces? • Pièces manquantes?

¿Partes faltantes? • Perdeu peças?  
Fehlende Teile? • Не хватает деталей?

[support.megabrands.com](http://support.megabrands.com)

Instructions included for main model only. Other build(s) can be found at [megaunboxed.com](http://megaunboxed.com)  
Instructions incluses pour le modèle principal uniquement. Les instructions pour l'(les) autre(s) modèle(s) de construction se trouvent sur le site [megaunboxed.com](http://megaunboxed.com) / Nur für das Hauptmodell ist eine Anleitung enthalten. Unter [megaunboxed.com](http://megaunboxed.com) finden Sie weitere Bauanleitungen. Istruzioni incluse solo per il modello principale. È possibile trovare le altre costruzioni su [megaunboxed.com](http://megaunboxed.com) / Instructies alleen bij het hoofdmodel. Andere bouwmodeljkheden kunt u vinden op [megaunboxed.com](http://megaunboxed.com) / Se incluyen las instrucciones para el modelo principal solamente. Se pueden encontrar otras construcciones en [megaunboxed.com](http://megaunboxed.com) / Instruções incluídas somente para o modelo principal. Outras montagens podem ser encontradas em [megaunboxed.com](http://megaunboxed.com) / Instruktioner medföljer endast för huvudmodellen. Andra byggen finns på [megaunboxed.com](http://megaunboxed.com) / Ohjeet ovat sisällytettävä vain päämalliin. Muut kokoonpanot ovat löydettävissä osoitteessa [megaunboxed.com](http://megaunboxed.com)  
Vejlædningen følger kun med hovedmodellen. Andre byggemodeller kan findes på [megaunboxed.com](http://megaunboxed.com)  
Instruksjoner kun inkludert for hovedmodell. Annen/andre versjon/-er finner du på [megaunboxed.com](http://megaunboxed.com) / Zależąco instrukcje tylko do głównego modelu. Inne wersje są dostępne na [megaunboxed.com](http://megaunboxed.com) / Přibalené pokyny jsou pouze pro hlavní model. Ostatní stavby lze najít na [megaunboxed.com](http://megaunboxed.com) / A mellékelt útastások csak a fő modellre vonatkoznak. Egyéb építőelem(ek) a [megaunboxed.com](http://megaunboxed.com) weboldalon található(k) / Инструкция относится только к основной модели. Другие конструкции можно найти на сайте [megaunboxed.com](http://megaunboxed.com) / Οι οδηγίες που περιλαμβάνονται είναι μόνο για το κύριο μοντέλο. Μπορείτε να βρείτε άλλες κατασκευές στο [megaunboxed.com](http://megaunboxed.com) / Yönergeler sadece ana modeller için dahil edilmiştir. Diğer yapı parçaları [megaunboxed.com](http://megaunboxed.com) adresinde bulunabilir /  
メインのモデルのみの取扱説明書が含まれています。他の [megaunboxed.com](http://megaunboxed.com) にあります。 /  
التعليمات موجودة للنموذج الرئيسي فقط. يمكن العثور على بناء (أخرى) على موقع [megaunboxed.com](http://megaunboxed.com)

拼搭指南仅包含主体部分的拼搭指导。其他部分拼搭指导可以上 [megaunboxed.com](http://megaunboxed.com) 查找

Mattel Europa B.V., Gondel 1, 1186 MJ Amstelveen, Nederland. Mattel U.K. Limited, The Porter Building, 1 Brunel Way, Slough SL1 1FQ, UK. Mattel France, Parc de la Cerisaie, 1/3/5 allée des Fleurs, 94260 Fresnes Cedex. N° Cristal 0969 36 99 99 (Numéro non surtaxé) ou [www.lesjouetsmattel.fr](http://www.lesjouetsmattel.fr) Mattel Belgium, Trade Mart, Atomiumsquare, Bogota 202 – B 275, 1020 Brussels. Gratis nummer België: 0800 – 16 936 – Gratis nummer Luxemburg: 800 – 22 784 – Gratis nummer Nederland: 0800 – 262 88 35. Deutschland : Mattel GmbH, Solmsstraße 4, D-60486 Frankfurt am Main. Schweiz: Mattel AG, Kirchstrasse 24, CH-3097 Liebefeld. Österreich: Mattel Ges.m.b.H., Campus 21, Liebermannstraße A01 404, A- 2345 Brunn/Gebirge. Mattel Italy Srl, Via Bracco, 6-MAC 6, 20159 Milano, Italy. Servizio assistenza clienti: [Customersrvr.italia@mattel.com](mailto:Customersrvr.italia@mattel.com) - Numero verde 800 11 37 11. Mattel España, S.A., Aribau 200, 08036 Barcelona. [csevice.spain@mattel.com](mailto:csevice.spain@mattel.com) Tel: 900 102 390 <http://www.service.mattel.com/> es. Mattel East Asia Ltd., Room 503-09, North Tower, World Finance Centre, Harbour City, Tsimshatsui, HK, China. Tel: (852) 3185-6500. Diimport & Diedarkan Oleh: Mattel Continental Asia Sdn Bhd. Level 19, Tower 3, Avenue 7, No. 8 Jalan Kerinchi, Bangsar South, 59200 Kuala Lumpur, Malaysia. Mattel South Africa (PTY) LTD, Office 102 I3, 30 Melrose Boulevard, Johannesburg 2196. Dystrybutor: Mattel Poland Sp. z o.o., Warsaw Trade Tower 34 p., ul. Chłodna 51, 00-867 Warszawa. Mattel Australia Pty. Ltd., 658 Church St., Richmond, Victoria, 3121. Consumer Advisory Service - 1300 135 312. Mattel AEBE, Εθνάρχου Μακαρίου 1, Κτήριο Κ-2, ΤΚ 17561, Παλαιό Φάληρο. Mattel Oyuncakçılık Tic. Ltd. Şti. İçerenköy Mah., Erku Sok. A Blok No:12 Üner Plaza Kat:9-10 34752 Ataşehir İstanbul. Tel: 0216 570 75 00. Импортёр/Уполномоченная организация: ООО "МАТТЕЛ" Российская Федерация, 105120 Москва, 2-й Сыромятинский переулок, Л/п: +7 495 287 79 39. Mattel Czech Republic s.r.o., The Forum, Václavské nám. 19, 11000 Praha 1. Mattel, 333 Continental Boulevard, El Segundo, CA 90245, USA. Consumer Services: 1-800-465-MEGA (6342). Mattel Canada Inc., Mississauga, Ontario L5R 3W2. Consumer Services: You may call us free at/ Composez sans frais le 1-800-524-8697. Importado y distribuido por Mattel de México, S.A. de C.V., Miguel de Cervantes Saavedra No. 193, Pisos 10 y 11, Col. Granada, Alcaldía Miguel Hidalgo, C.P. 11520, México, Ciudad de México. R.F.C. MME-920701-NB3. Tels: 59-05-51-00 Ext. 5206 ó 01-800-463-59-89. Mattel Chile, S.A., Avenida América Vespuccio 501-B, Quilicura, Santiago. Tel: 1230-020-6213. Servicio al consumidor Venezuela: Tel: 0-800-100-9123. Mattel Argentina, S.A., Av. Libertador 1000, Piso 11 – Oficinas 109 y 111, Vicente López – Prov. Buenos Aires. Tel: 0800-666-3373. Mattel Colombia, S.A., Calle 123#7-07 P.5, Bogotá. Tel: 01800-710-2069. Mattel Perú, S.A., Av. Juan de Arona # 151, Centro Empresarial Juan de Arona, Torre C, Piso 7, Oficina 704, San Isidro, Lima 27, Perú. RUC: 20425853865. Reg. Importador: 02350-12-JUE-DIGESA. Tel: 0800-54744. E-mail Latinoamérica: [servicio.clientes@mattel.com](mailto:servicio.clientes@mattel.com). Mattel do Brasil Ltda.- CNPJ: 54.558.002/0001-20 - Rua Verbo Divino, 1488 - 2º. Andar - 04719-904 - Chácara Santo Antônio - São Paulo - SP - Brasil. Serviço de Atendimento ao Consumidor: fone 0800 575 0780. E-mail: [sac.matteldobrazil@mattel.com](mailto:sac.matteldobrazil@mattel.com)

# BUILD BIGGER BATTLES IMAGINEZ DES BATAILLES TOUJOURS PLUS GRANDES

CONSTRUYE BATALLAS AÚN MÁS GRANDES • CONSTRUA BATALHAS MAIORES  
BAUE NOCH GRÖßERE SCHLACHTEN • ПОСТРОЙТЕ НОВЫЕ БИТВЫ



HHC36

HHC42

Set(s) sold separately and subject to availability. / Ensemble(s) vendu(s) séparément. Certains produits peuvent ne pas être commercialisés. / Se vende(n) por separado y está(n) sujeto(s) a disponibilidad. Conjunto(s) vendido(s) em separado e sujeito(s) à disponibilidade. / Set in vendita separatamente, secondo disponibilità. / Das/Die Set(s) sind separat erhältlich. / Zestaw(y) sprzedawany(e) oddzielnie w zależności od dostępności. / Set(s) apart verkrijgbaar en afhankelijk van beschikbaarheid. / Набор(-ы) продаются отдельно, при наличии. / Sæt sælges separat og så længe lager haves. / Seten säljs separat så länge lagret räcker. / Settet/settene selges separat så langt lageret rekker. / Pakkaus/pakkaukset myydään erikseen, saatavuus voi vaihdella. / Το(α) σετ πωλούνται ξεχωριστά και ανάλογα με τη διαθεσιμότητα. / Setler ayrı olarak satılır ve stoklarla sınırlıdır. / Set (sety) se prodává (prodávají) samostatně dle aktuální nabídky. / Súprava-/y sa predáva(jú) samostatne a podľa dostupnosti. / A készlet(ek) külön kapható(k), az elérhetőség változhat. /

تُباع المجموعة أو المجموعات على حدة وتخضع لتوافرها. / セット商品は別売りになります。在庫状況は別途ご確認をお願いします。 / 每套单独发售，按供货情况决定。

Mattel Canada Inc. Mississauga, Ontario L5R 3W2.  
MADE IN CHINA. FABRIQUÉ EN CHINE. FABRICADO NA / HECHO EN CHINA.  
ИЗГОТОВЛЕНО В КИТАЕ. ÇIN'DE ÜRETİLMİŞTİR. صنع في الصين



© 2022 Microsoft Corporation. All Rights Reserved. Microsoft, Halo, the Halo logo, Xbox, the Xbox logo, and 343 Industries are trademarks of the Microsoft group of companies.

©2022 MEGA Brands &™ MEGA Brands.  
Printed in China / Imprimé en Chine

AD-GYG59-02

P D714,887, D781,964, D797,203, D841,101 1186 MJ, 1, NL

