

## Sierra Diverse Ballpoint Pen Hardware Kit

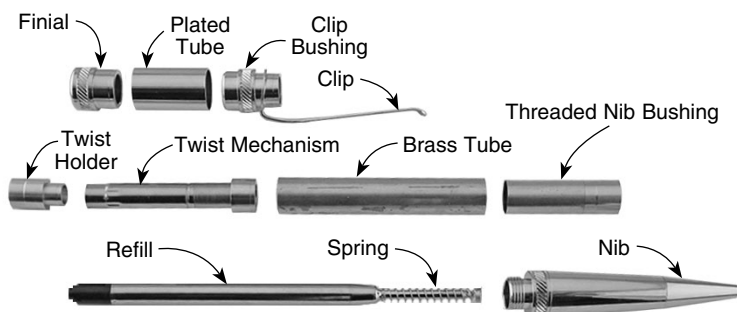

Requires standard A mandrel, bushings for Sierra Diverse pen (88K83.58), 13/32" drill bit, and minimum 3/4" square x 3" blank.



Sierra Diverse ballpoint pen parts.

### Preparing the Material Blank

1. Only one material blank is required for this pen. Cut the material blank a little longer than the brass tube.
2. Drill the blank through the center, lengthwise, with the 13/32" drill bit.
3. Polish the brass tube with sandpaper. This can be done by hand or on a power machine such as a belt sander. The purpose of the sanding is to clean off the oxidation and roughen the tube so that the glue will have a better adhesion surface.
4. Plug the ends of the tube with the material of your choice. Some use base wax (a dental product), or play dough, or even a slice of potato. Just push the ends of the tube into a thin section of the material. This will form a plug to keep the glue from getting into the tube.
5. Clean the tube, after plugging, with acetone or alcohol on a rag.
6. Prepare your glue. You can use a fast-drying, two-part epoxy, one hour or less. Be sure to mix it thoroughly. (A Post-it® Note pad makes an excellent mixing place. When you are finished just tear it off and throw it away.) Polyurethanes and thick flexible cyanoacrylates (CAs) can also be used. (If not using epoxy, go to step 9.)
7. Place some of the epoxy into the blank using a small piece of dowel or other small stick.
8. Roll the tube in the epoxy.
9. Insert the tube with a twisting motion until it is almost all the way into the material blank. Then use the dowel to push it in until the end is flush with the blank. Use the dowel to rake off the excess glue even with the blank and the tube.
10. Push the brass tube through the blank until the other end is flush with the blank. Then rake the glue flush with that end. Now push the tube back into the blank until the tube ends are equidistant from the ends of the blank.
11. Set it aside for 60 minutes until the epoxy has had time to reach its maximum strength.

12. If you are using CA glue, the wait is only about 60 seconds. When using polyurethane the wait will be about 24 hours.
13. When the glue has cured, use a hobby knife to remove the plugs from the ends. It is also a good idea to clean the tube with a brass gun-cleaning brush or a rolled up piece of sandpaper to remove any glue that may have gotten into the tube.
14. Not cleaning out all glue from the tube is the most common cause of pen failure. **Be certain** that all dried glue is removed from inside the tube before proceeding.
15. Using a barrel trimmer of the proper size, face off each end of the blank until it just touches the brass end of the tube. **Stop** facing at this point. Your pen's proper operation is dependent on having the proper length tubes. This facing operation can also be done with the proper jig and a disc or belt sander.
16. Not having the proper tube length is the #2 cause of pen failure. Sanding, on a disc sander, using a jig to hold the tube square with the disc, is a more sure way of getting the proper length. It should be tried if you have any doubt as to your abilities to square the material with the barrel trimmer.
17. Another good method of squaring the ends of the blank is to turn the blank until it is just round. Using a miter gauge to maintain the blank perpendicular to the sanding disc, just touch the ends to the disc. Once the blank is square and you can see the ends of the tube brighten, then return the blank to the mandrel and finish the turning until the desired contour is accomplished.

### Turning the Blank

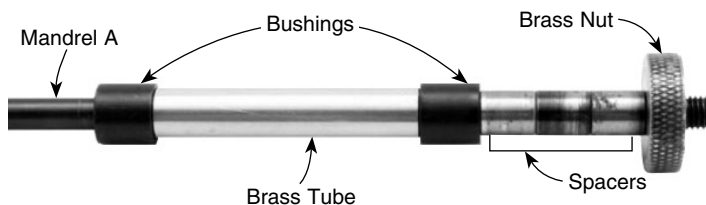

1. Assemble the blank on the mandrel using the bushings. The bushings are all the same size.
2. Since there is only one blank to place on the mandrel, you will have to place spacers on the mandrel in order to tighten the tube for turning. You can use a piece of wood with a 7 mm hole or use 7 mm bushings as spacers.
3. Tighten the tailstock before tightening the blank on the mandrel. This will center the mandrel first. Then tighten the nut that holds the blank.
4. Turn the blank to the desired contour, making sure that the area next to the bushing is turned to the size of the adjacent bushing.
5. After turning the blank, sand the surface in progressive steps until you get to 400 or 500 grit.
6. Apply the finish of your choice and polish.
7. Remove the blank from the mandrel.

## Assembling the Pen

Please refer to the pen parts photograph.

The third most common error resulting in a non-functional or damaged pen is the misalignment of the parts when pressing them in place. The use of a good pen press or small arbor press is recommended, but it can be accomplished with a good C-clamp and much care. When pressing in the various parts, by any means, **be sure** that the parts are straight and in line with the blank. If a part is cocked or otherwise misaligned, at the very least, a poor fitting pen will result. At the worst, you may have a pen that is not usable. Exercise caution here!

Occasionally, you will encounter parts that are a little loose fitting. This can be corrected by using a **small** spot of glue, usually CA, on these parts before pressing them home.

1. Press the twist holder into the finial.
2. Press this this assembly into the plated tube.
3. Insert the clip bushing into the other end of the plated tube.  
*Note: Complete this step by hand; not with a pen press.*
4. Slide the clip onto the clip bushing and set the finial/clip assembly aside.
5. Press the unthreaded end of the treaded nib bushing into one end of the pen blank until the other end of the bushing is flush with the blank.
6. Press the broad end of the twist mechanism into the other end of the pen blank until it stops, taking care not to force it or press too hard.
7. Press the finial/clip assembly onto the narrow end of the twist mechanism, taking care not to force it or press too hard.
8. Drop the refill into the other end of this assembly, making sure that the spring is in place.
9. Fit the nib over the refill and thread it onto the nib bushing. Check for proper operation.

This pen uses a standard Parker-style pen refill (88K78.55, pkg. of 5). To change the refill, simply unscrew the nib. **Do not pull.**