

# Square Hole-Punches

---

The square-hole punches are small, hand-held hollow chisels for making square holes for decorative plugs, such as used in Greene and Greene style work. Available in six sizes:  $\frac{3}{16}$ " ,  $\frac{1}{4}$ " ,  $\frac{5}{16}$ " ,  $\frac{3}{8}$ " ,  $\frac{7}{16}$ " , and  $\frac{1}{2}$ " . The tips of the punches are made from O1 tool steel and are hardened to Rc48-52; the punch bodies or handles are steel.

*Note: Each punch requires a drill bit  $\frac{3}{64}$ " smaller than the punch size (e.g., the  $\frac{1}{4}$ " punch requires a  $\frac{13}{64}$ " drill bit).*

1. Lay out the desired hole location and mark the center.
2. Drill the hole with the appropriately sized drill bit (punch dimension minus  $\frac{3}{64}$ " ).
3. Remove the drill bit from the drill and insert the drill bit into the hole.
4. Slide the punch down over the drill bit. (The drill bit locates the punch.)
5. First square the punch to the surface of the workpiece, then register it to the workpiece with downward pressure.
6. Remove the drill bit.
7. Strike the punch with a mallet or hammer to cut the square hole.

 **Caution:** Avoid using a steel hammer, as it will deform the top of the punch body.

8. Clean the hole out with a dental pick (if required).

## Sharpening the Punches

For easy sharpening, we recommend a pair of diamond cone sharpeners for square-hole punches (77J81.24). The coarse one is for the basic grind and the fine one is for a micro-bevel on the corners. Alternatively, the inside corners can be honed with a round stone.

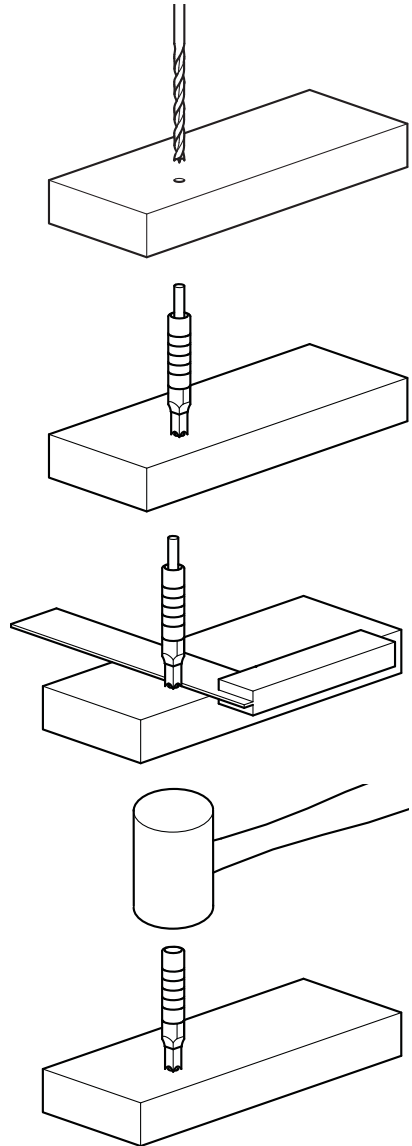

## Accessories

- 07J02.09** 9/64" HSS Brad-Point Drill Bit (for use with 3/16" punch)
- 07J02.13** 13/64" HSS Brad-Point Drill Bit (for use with 1/4" punch)
- 07J02.17** 17/64" HSS Brad-Point Drill Bit (for use with 5/16" punch)
- 07J02.21** 21/64" HSS Brad-Point Drill Bit (for use with 3/8" punch)
- 07J02.25** 25/64" HSS Brad-Point Drill Bit (for use with 7/16" punch)
- 07J02.29** 29/64" HSS Brad-Point Drill Bit (for use with 1/2" punch)
- 77J81.24** Sharpeners for Square-Hole Punches, pair