

02K4114 The following instructions were provided by the manufacturer.

# QUICK INSTALLATION GUIDE OF NJ-28010

Pocket Door Slide, 25 pound (11 kgs) loading



## Before You Start

\* The DIM. Might vary due to different manufactures and hinge types

- A. Read the instruction thoroughly before installation
  - B. Make sure all components are included in the package
- |  |                                   |
|--|-----------------------------------|
| 1 Right Hand and 1 Left Hand Pocket Door Slide | 18 5/8" Pan Head wood screws      |
| 4 5/8" Flat Head wood screws                   | 4 M4 x 6 machine screws           |
| 2 Guide Rollers                                | 2 23 mm wood screws               |
|  | 2 M4 x 6 Round Head machine screw |
|  | 2 Hinges ( Bought Separately )    |

**Attach metal follower strip onto slides by M4 screws, or wooden follower strip onto slides by pan head screws 5/8".**

A. For wooden follower strip, please cut wooden strip to the DIM. L( cabinet height-156 mm ) x W (68~70 mm) x T ( 16~19 mm )

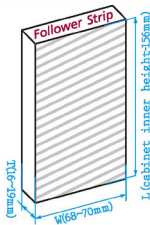

B. For the door larger than 42", and the 3rd slide is suggested to be utilized for a better load capacity.

**Step 1 > Mount the hinge plate onto slide by flat head screw M4 x 6 mm**

**Step 2 > Place slides as Figure A which mount the lower side slide down to the cabinet bottom**

DIM A1: Door thickness + 3 mm. Install pan head screws through horizontal slot holes for adjustment first, then screw the round hole for fixing purpose.

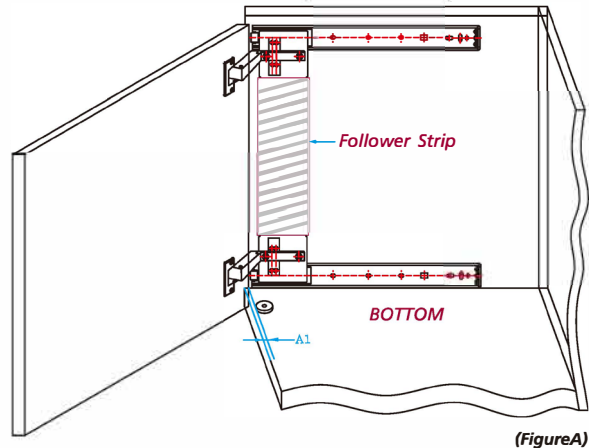

**Step 3 > Bore the hinge cup holes as shown on Figure B**

- DIM B1: 39~40 mm is recommended.
- DIM B2: 7~8 mm is recommended.
- DIM B3: ( Upper slide center to lower slide center distance ) - 46 mm.

**Step 4 > Mount the hinge cup onto the door by flat head 5/8" screws.**

**Step 5 > Install the guide rollers on the top and bottom of cabinet as figure C.**

DIM. C1: Door thickness + 9.5 mm ( roller dia. / 2 ) + 9.8 mm slide thickness + 3 mm ( movement clearance ).

DIM. C2: Door thickness + 9.5 mm (roller dia. / 2 )

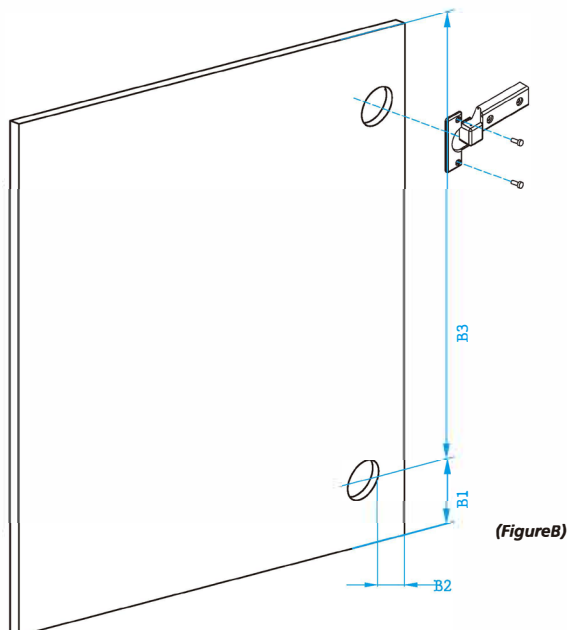

**Step 6 > Attach the door onto cabinet by hinges. ( Bought Separately )**

Tips on door gap adjustments. For upper and lower gaps, please adjust mounting plate vertical position.

1. For door left or right side gaps, please adjust C3.
2. Adjust C4 screw for door close position in-out adjustment.

