

NX60 Premium Block Plane

The body of this block plane by Veritas is nickel-resist ductile cast iron, a material much more durable as well as more stable than gray iron, having been fully stress relieved. Furthermore, the addition of nickel to the alloy gives the material the same rust-resistant properties as stainless steel. All of the turned knobs and adjusters are made from stainless steel.

The body is accurately machined and surface ground so that the sole is flat, the sides are square to the sole, and the bed is flat and square to the sides, all to within 0.0015" maximum deviation. The large side wings increase stability for shooting and the unique finger grip indentations provide comfort and control.

The plane's adjustable mouth may be closed to a narrow slit for fine shavings with minimum tear-out or opened for heavier cuts. Adjustment is done quickly and easily with a stainless-steel locking knob. A set screw behind the front knob can be used to lock in a setting so that the mouth can be opened to clear chips and then returned to the exact opening. Should you accidentally hit a bench dog when planing, the toe won't move, since it is completely enclosed by the body casting.

The lever cap surfaces integrate with the body form to give a secure and comfortable grip, and hold the blade directly over the bed at the front and on a large clamping pad at the rear. The lever cap wheel (underneath the lever cap) can be easily set from a full locking position to a controlled friction setting for blade adjustment. The combined feed and lateral adjustment mechanism makes blade setting accurate and easy.

This 7" long by 1 3/4" wide plane has a 12° bed angle. The 1 3/8" wide blade is 1/8" thick, with a 25° primary bevel. It is available in your choice of A2, O1 and PM-V11 tool steel. All that is required is to hone your preferred micro-bevel. The blade back has been lapped to be perfectly smooth, so it should never need lapping prior to sharpening.

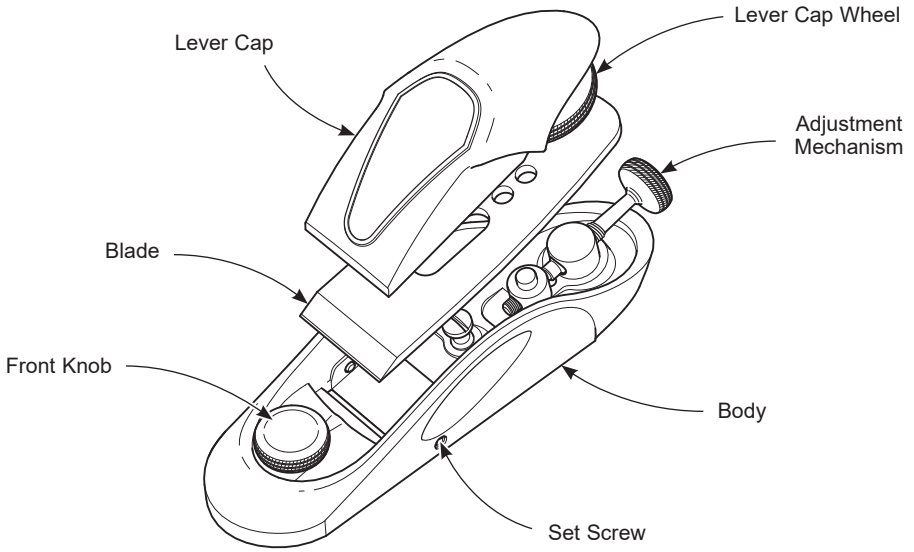

Figure 1: Plane components.

This block plane may be used with one or two hands. For a one-handed grip, put the tip of your index finger in the front knob depression, rest your palm on the lever cap and grip the plane sides with your second and third fingers in the indentations on one side and your thumb in the indentations on the other side. For additional force (or control), you can use a two-handed grip, with one hand holding the front of the plane and the other hand using the side indentations. Or, you can augment the one-handed grip by pinching the leading corner of the body between the thumb and forefinger of the other hand.

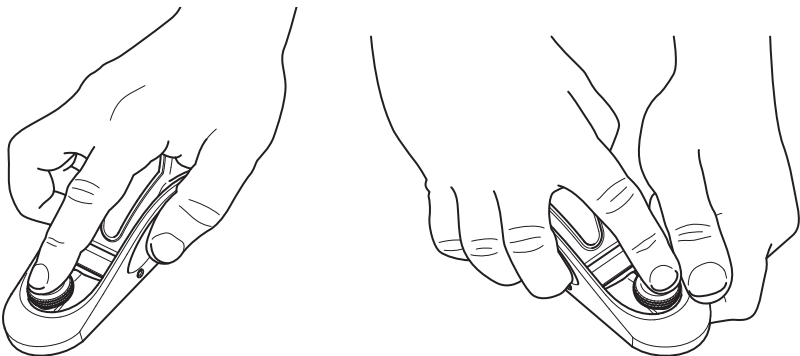



Figure 2: Holding the plane.

Blade Adjustment

 **Caution:** Be aware that the blade is sharp; careless handling can result in serious injury.

To initially set the blade, open the mouth fully, and place the plane on a flat wood surface. Lightly clamp the blade with the lever cap wheel and advance the blade until it just touches the wood.

Flip the plane to a sole-up position, then sight along the sole to ensure the blade edge is parallel to the sole and advance or retract it as required. Clamp fully (a quarter turn should be ample — **do not overclamp**) and take a test cut. If all is well, advance the set screws on either side of the body until they just touch the blade, not to clamp it but to create a guide so that you do not have to be concerned about the blade shifting sideways at the front. All lateral adjustment will now be governed entirely by the movement of the lateral adjust/feed lever.

The adjustment mechanism is retained in the body by a small set screw in the back of the housing. If you need to remove the mechanism, back this set screw off until the mechanism can be removed. (It is not necessary to completely remove the set screw.) When reinstalling the mechanism, tighten the set screw until such that the mechanism cannot be removed.

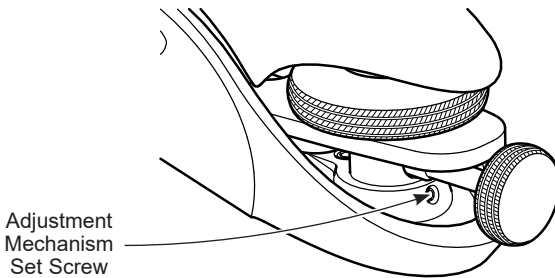

Figure 3: Set screw that holds the adjustment mechanism in the body.

Two Cautionary Notes

1. The lever cap wheel has tremendous mechanical advantage. For normal use, it needs to be tightened only a quarter turn after full engagement with the blade. **Never torque it down as hard as you can or you may damage the plane.**
2. Before advancing the blade at any time, check the mouth opening to be sure you don't run the blade against the adjustable toe piece. It is a simple matter to close the mouth to the desired opening **after** you have reached the right blade projection. Better to dull the blade in use than when adjusting it.

Backlash and How To Avoid It

While this block plane is made with tight tolerances and has precisely machined threads in the adjuster components to minimize backlash in the assembly (typically, backlash should be no more than a quarter turn), it is still good practice to adjust the blade in a way that eliminates the possibility of the blade shifting backward as the backlash is taken up. The final setting should always be made with the blade being advanced by the clockwise movement of the thumbscrew. If you need to retract the blade slightly, retract it more than required, and finish by **advancing** it to its desired position.

Mouth Adjustment

The movable toe piece enables you to quickly and accurately set the mouth opening between the blade and the toe piece to suit the task. Generally, you will want a mouth as small as will allow the shaving to escape. The reason for this is that a tight mouth supports the wood ahead of the blade, preventing breakout.

Loosen the front knob and adjust the position of the toe by sliding the front knob forward or backward, as required. Tighten the front knob firmly, but avoid overtightening.

The set screw behind the front knob can be used to limit the rearward motion of the toe, allowing you to open the mouth to remove wood chips and then return the toe exactly to where it was.

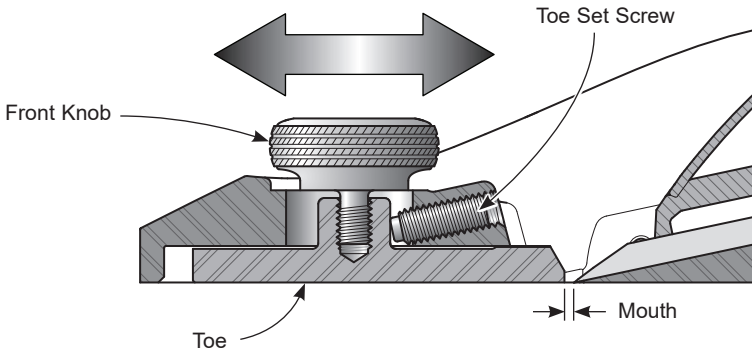

Figure 4: Mouth adjustment.

Applications

This block plane is intended for general-purpose work, such as chamfers, trimming and fitting moldings, fitting drawers, and small smoothing operations. The low bed angle makes it an ideal plane for working end grain, such as squaring or trimming on a shooting board.

Cutting End Grain

Planing end grain involves a lot of force. It is therefore important not only to have the workpiece firmly clamped in position, but also to use a sharp blade. If possible, clamp the workpiece upright in a vise, keeping it low so that it will be secure and comfortable to work. You can prevent the edge of the workpiece from splitting when planing end grain by clamping a small scrap block to the edge. Skew the plane to lower the effective bevel angle.

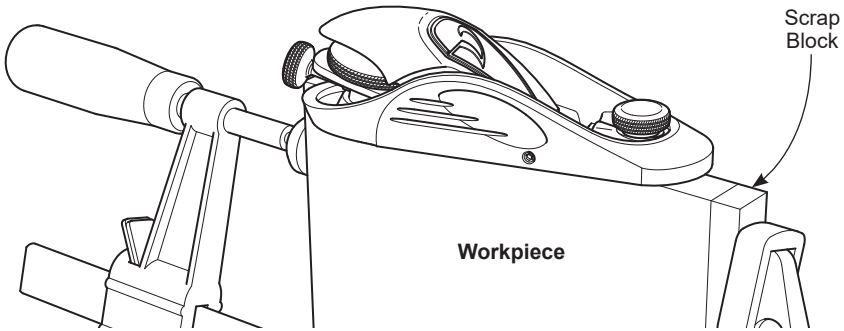

Figure 5: Preventing splitting.

Another way to plane end grain is to make use of a shooting board. It guides the plane to cut a perfectly square edge (or a bevelled edge if you want), and holds the workpiece in such a way as to prevent splintering of the end-grain fibers. Shooting boards can be as simple as illustrated or arranged in such a way as to shoot miters or configured with a molded stop to fit a matching molded profile.

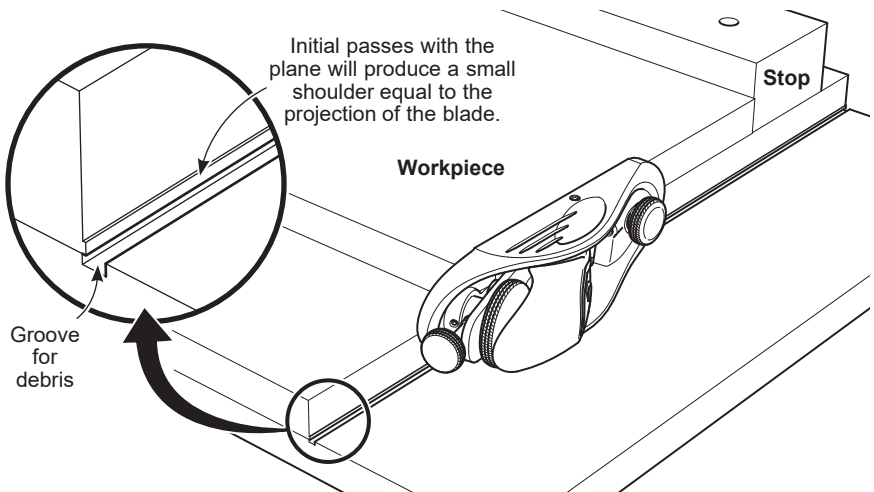

Figure 6: Planing end grain with the block plane.

Blade Sharpening

This block plane has a 12° bed angle and the blade comes with a primary bevel of 25°. A micro-bevel will need to be honed using very fine abrasives. (An angle of 27° is recommended.) The micro-bevel results in a more durable edge and reduces the effort needed to hone the edge without adversely affecting the cutting action of the blade.

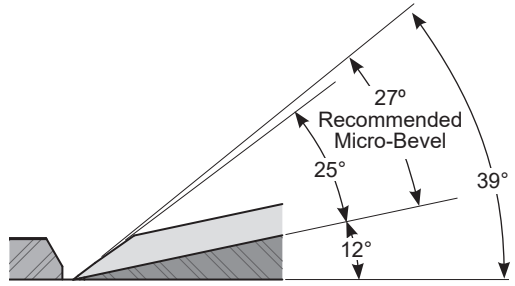

Figure 7: Recommended blade geometry of the low-angle block plane, with a 27° micro-bevel.

Since the blade is used bevel up, the effective cutting angle will be 39°. This blade geometry is ideal for fine trimming work on end-grain softwood and some hardwoods; however, you can (and should) adjust the micro-bevel angle to suit the work you are doing. Ring-porous hardwoods such as oak may require a 30° bevel to prevent blade edge failure.

With your bevel and cutting angles set for the demands of end-grain work, you will easily deal with parallel grain cutting.

Care and Maintenance

The body of this plane is nickel-resist ductile iron, and since the turned parts are all stainless steel, they are inherently rust resistant. The blade, however, will need to be protected from corrosion, particularly if the plane is to be stored for long periods of time.

While the body does not need corrosion protection, a light coat of silicone-free paste wax on the running surfaces will act as a lubricant for smoother planing. Wipe off any wood dust from the surfaces that you will be waxing, apply a light wax coating, let dry, then buff with a clean soft cloth.

If storage conditions are damp or humid, the plane should, in addition to the treatment outlined above, be wrapped in a cloth or stored in a plane sack (as the blade is not made from a rust-resistant material). This precaution will also guard against dings and scratches.

Accessories

- 05P70.03** A2 Blade
- 05P70.05** O1 Blade
- 05P70.07** PM-V11 Blade