

Sewing Machine Lift

(02K01.01)

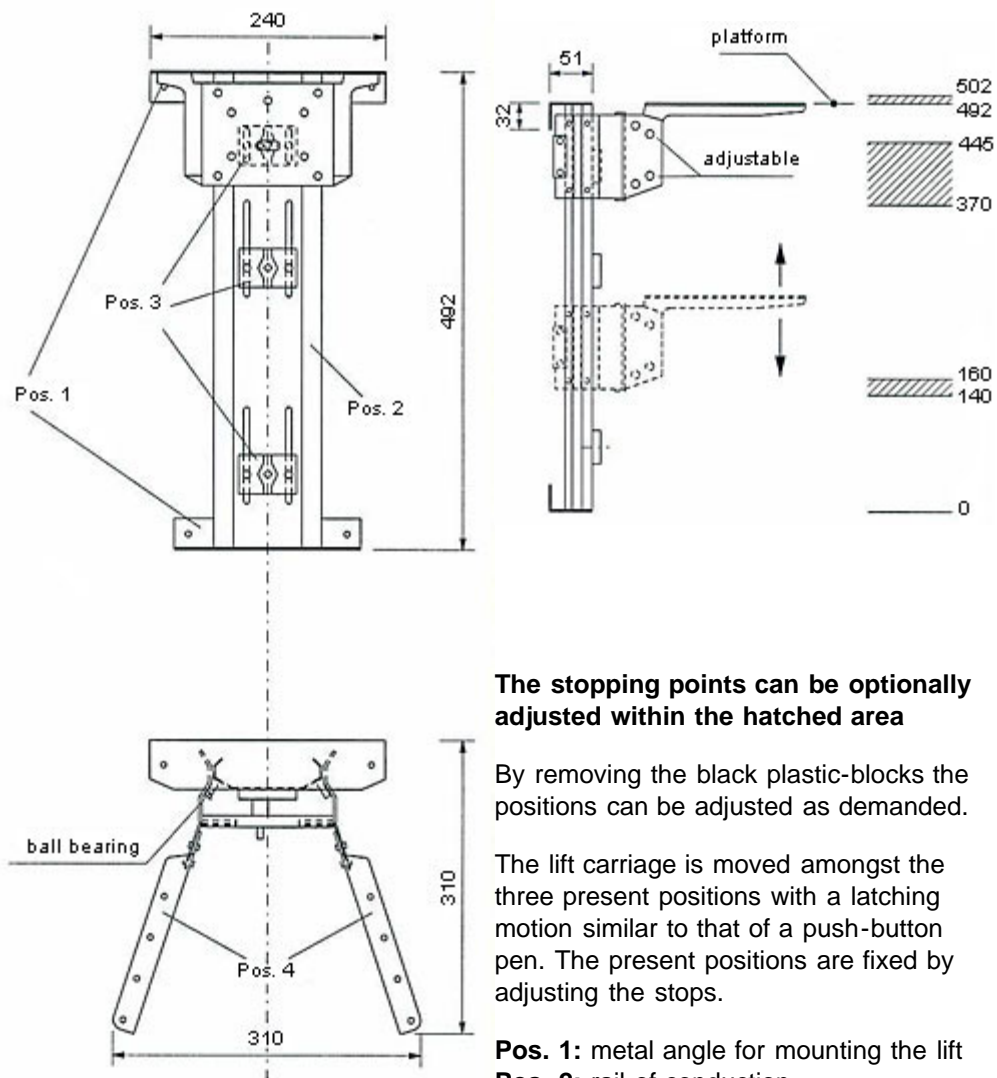

The stopping points can be optionally adjusted within the hatched area

By removing the black plastic-blocks the positions can be adjusted as demanded.

The lift carriage is moved amongst the three present positions with a latching motion similar to that of a push-button pen. The present positions are fixed by adjusting the stops.

- Pos. 1:** metal angle for mounting the lift
- Pos. 2:** rail of conduction
- Pos. 3:** adjustable stop
- Pos. 4:** metal angle for mounting the table