

Router Sled Hardware Kit

When working with oversize live-edge slabs or reclaimed lumber from old barns, a rig for carrying a router to flatten them in a reliable and consistent manner is required since they are too large to pass through a standard workshop jointer or thickness planer. This kit comprises the specialty hardware needed to build such a rig.

Notes:

- *The rig you build with this kit will produce a flat surface on wood, but not necessarily a smooth one. Additional smoothing operations should be expected.*
- *Since slab flattening takes up space, produces wood chips and generates noise; and it does a lot of all three, you may want to consider working outside.*

To complete the construction of your router sled, you will also need nominal 1 1/2" or 41 mm steel tube, strap clamps, a rigid user-built frame, and a router (min. 2 hp) with a suitable flattening router bit.

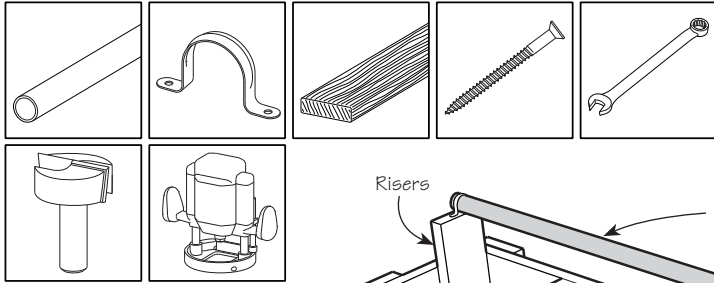

Kit Components		
Qty.	Description	
1	Router Carrier	
2	Trunnion	
120	Nylon Wheel	
16	U-Bolt	
50	Hex Nut	
50	Washer	

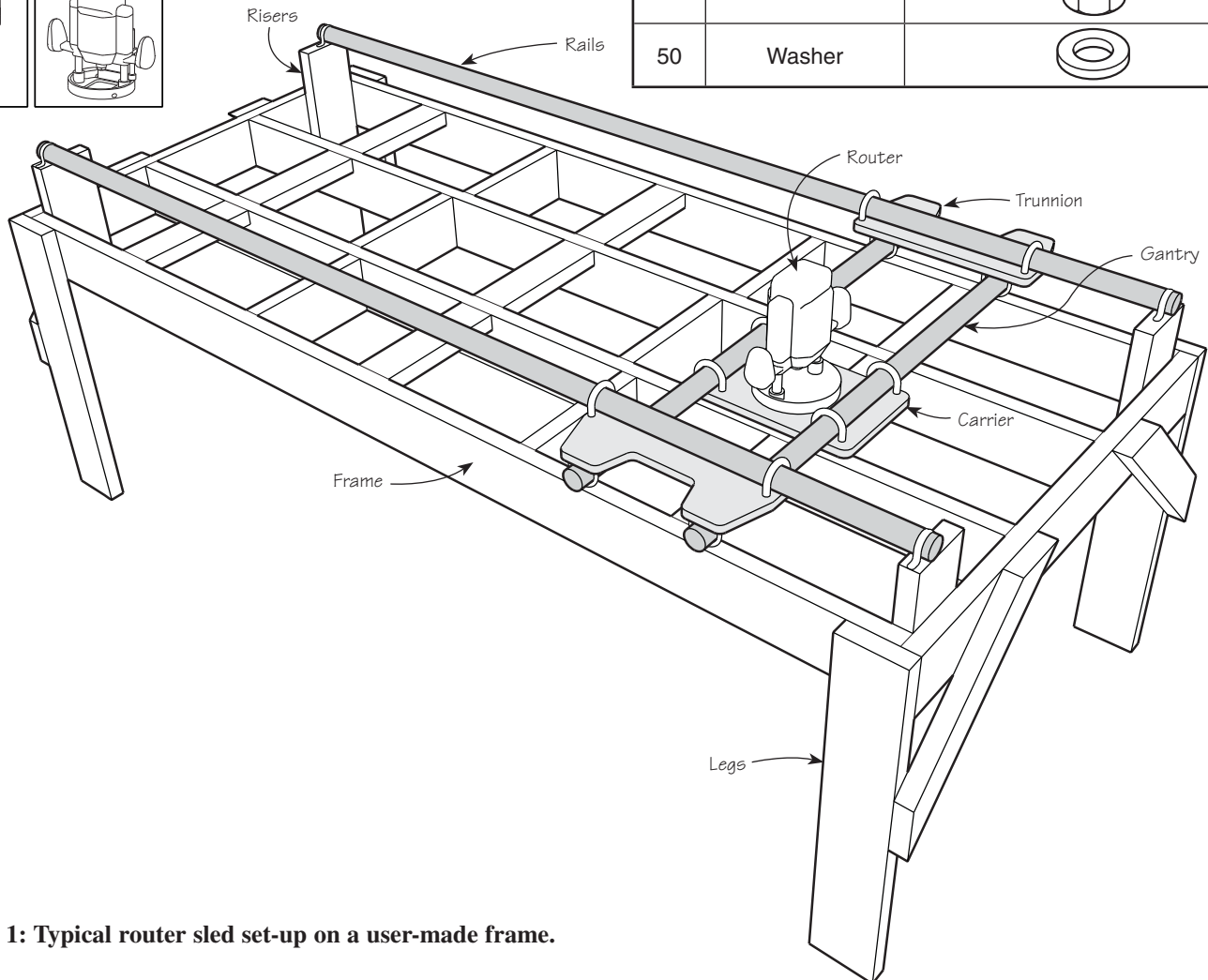

Figure 1: Typical router sled set-up on a user-made frame.

Steel Tube

The rails and the gantry are made from steel tube. The correct size of steel tube is important for proper operation of the glides. In North America, you will require nominal 1½" EMT (Electrical Metallic Tubing); elsewhere, nominal 41 mm ERW (Electric Resistance Welded) tube (1.74" or 44.2 mm actual outside diameter).

EMT or ERW tube is typically available in 10' (3 m) lengths. If you purchase three lengths and cut one in half, the result will be a 5' × 10' (1.5 m × 3 m) rig. This is the maximum size that can be built with this kit. Anything larger runs a risk of sagging, which will result in a dished surface.

Alternatively, two lengths of tube cut at approximately the one-third mark can be used to build a 3' × 7' or 1 m × 2 m rig.

In-between sizes, such as 4' × 8' or 1.2 m × 2.4 m, are also possible.

When determining the size of your rig, be aware that the effective working area of the router sled is less than the lengths of the tube used, as shown in **Figure 2**.

The table below shows the corresponding dimensions for the rigid frame, as well as the effective working area for three sizes of router sleds.

Nominal Size (Tube Lengths)	Frame Dimensions	Effective Working Area
5' × 10' 1.5 m × 3 m	54" × 123" 135 cm × 305 cm	36" × 100" 90 cm × 250 cm
4' × 8' 1.2 m × 2.4 m	42" × 99" 105 cm × 245 cm	24" × 76" 60 cm × 190 cm
3' × 7' 1 m × 2 m	30" × 87" 85 cm × 205 cm	12" × 64" 40 cm × 150 cm

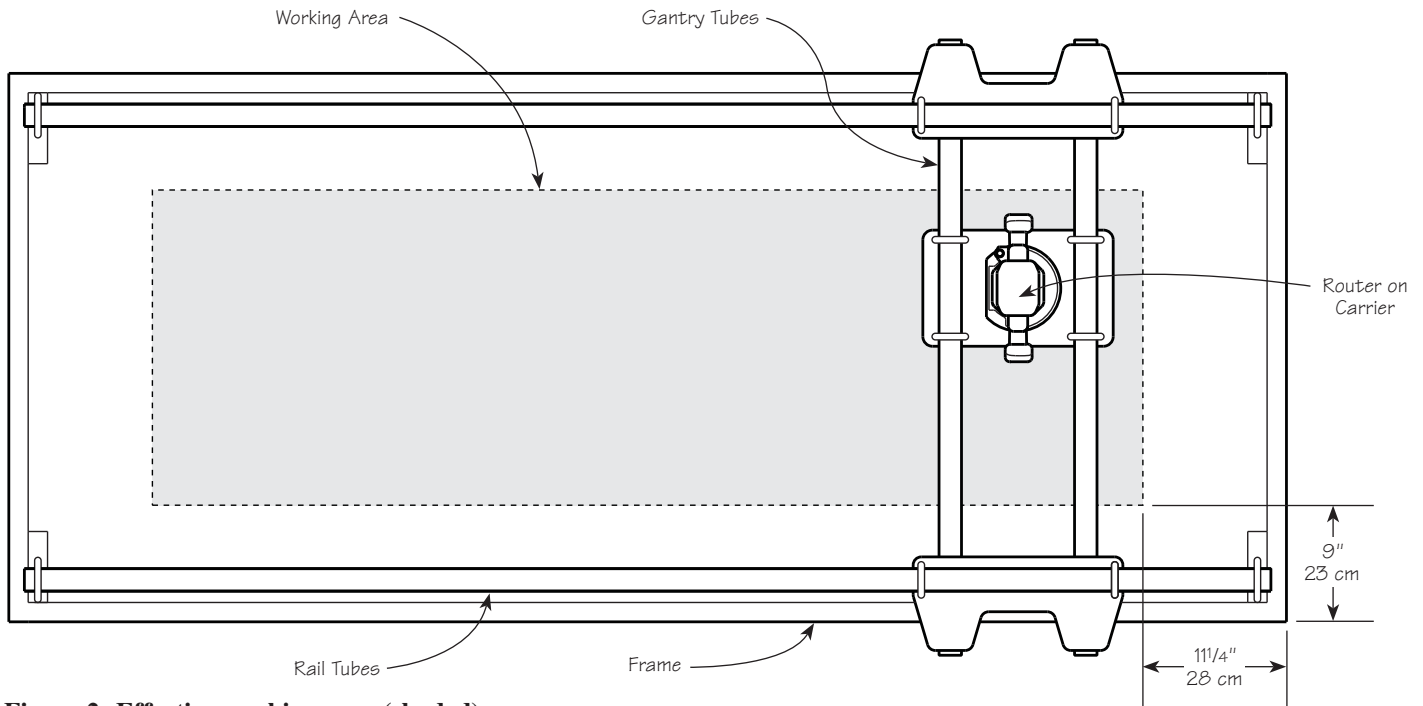

Figure 2: Effective working area (shaded).

Assembling the Router Sled Components

The router sled is built from a collection of sub-assemblies. This allows you to reconfigure the rig as needed to suit your current project.

Glide Assemblies

Eight glide assemblies are required for the sled. Assemble each as follows:

1. Thread a single hex nut onto one of the U-bolts until just before it bottoms out.
2. Slide on 13 or 14 nylon wheels, as needed.
3. Thread on a second hex nut to hold all the wheels in place.
4. Adjust the two hex nuts such the two exposed threaded ends are about the same length and such that the wheels can still spin freely but do not rattle.

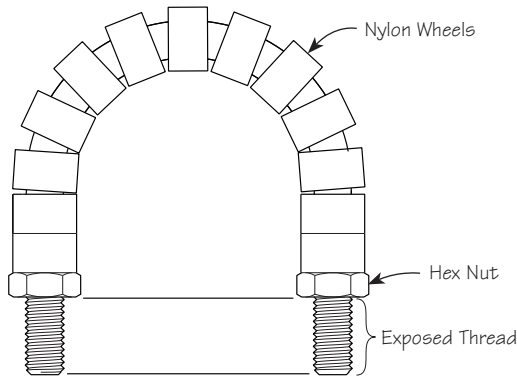

Figure 3: Glide assembly.

Trunnion Assemblies

Each trunnion has 12 holes drilled to accept two glide assemblies and four U-bolts. The four holes for the glide assemblies are counterbored. The remaining holes are for the U-bolts that fasten the trunnion to the gantry tubes. This forms the gantry of the router sled.

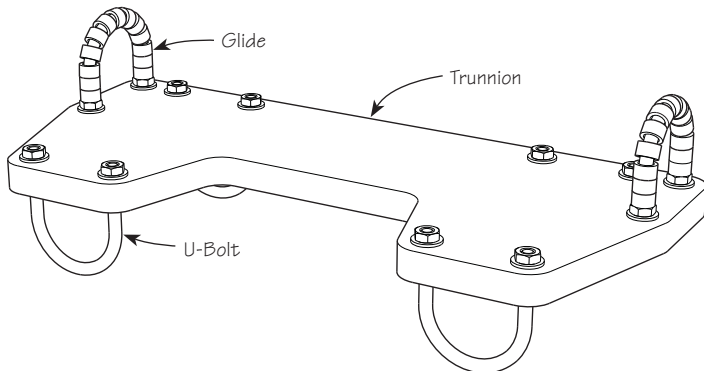

Figure 4: Trunnion assembly.

1. Into each pair of counterbored holes, install a glide assembly using four washers and two additional nuts, as shown in **Figure 5**. Tighten only the nuts in the counterbore.

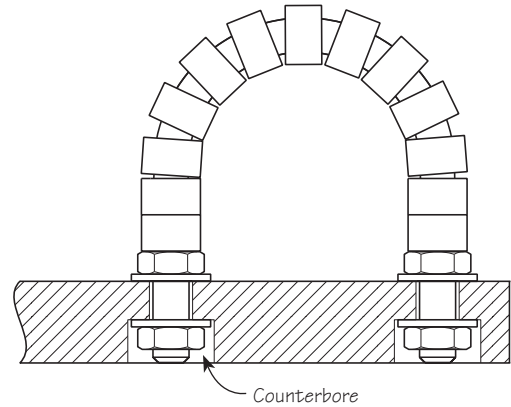

Figure 5: Glide assembly mounted in counterbored holes in trunnion.

2. In the remaining four hole-pairs, install a U-bolt on the opposite face using a single washer and nut per end. Do not thread these nuts on too far as some slack will be needed when installing the tubes for the gantry.

Router Carrier

The router carrier allows the router to move along the gantry.

1. Place the router carrier on a workbench.
2. Drop your router to its lowest setting and roughly center it over the opening on the carrier. Orient the router such that its handles will be roughly parallel with the gantry tubes. This isn't critical, but it will make using the router sled easier. Check to make sure that the router's handles will not interfere with the gantry tubes.
3. Mark the hole locations of your router's base plate.
4. Drill the marked holes in the router carrier. Be aware that the carrier counterbores will be on the underside of the final assembly (see **Figure 6**).
5. Attach four glide assemblies to the router carrier in the same manner as for the trunnion assembly.
6. Fasten your router to the carrier using appropriately sized screws. Be sure to recess these screws such that they cannot scrape your workpieces.

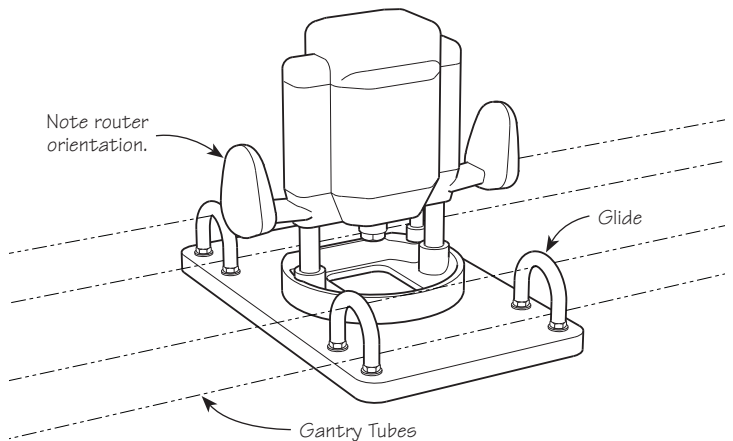

Figure 6: Router carrier assembly.

Rigid Frame

A flat and rigid frame is essential for properly milling a surface. The plans at the end of these instructions provide the frame dimensions for a 5' x 10' (1.5 m x 3 m) rig.

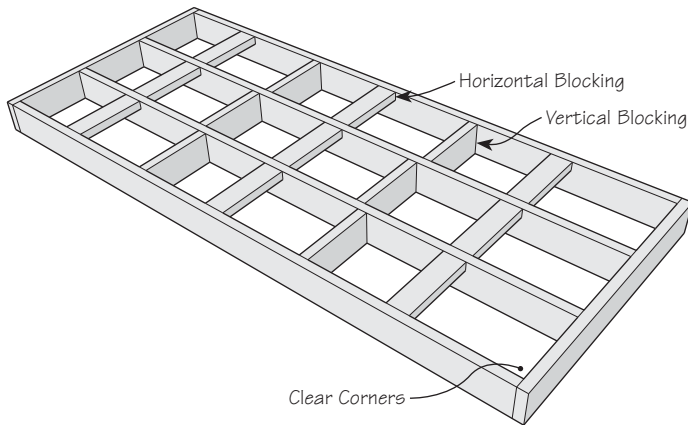

Figure 7: Example of a user-built rigid frame.

Careful selection of lumber free of crooks, kinks, cupping or twist is strongly recommended. Slightly bowed lumber can be used as it is easy to straighten with blocking.

Your rigid frame should:

- Be built from 2x6 or 2x8 lumber.
- Be assembled with screws for easy adjustments.
- Include plenty of vertical blocking for rigidity.
- Include horizontal blocking for locating workpieces.
- Have open spaces to allow the wood chips to fall through.
- Have clear corners for mounting risers.

While you build your rigid frame, frequently check that it has not become twisted during construction. Use a long board selected for its straightness, place it across both diagonals and compare the two results.

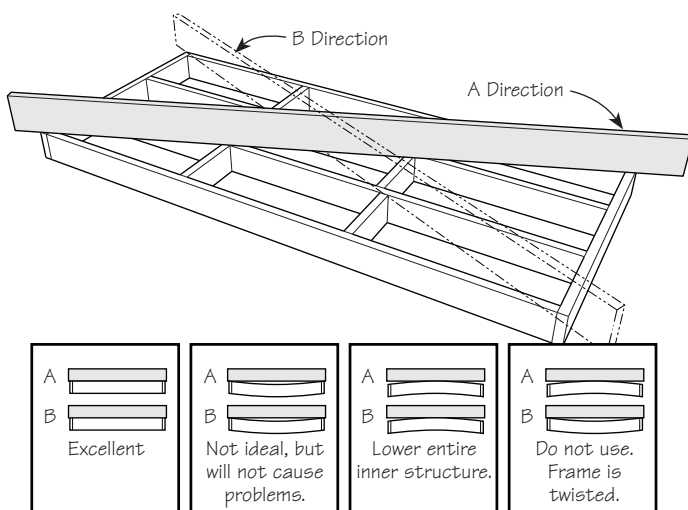

Figure 8: Checking frame for twists.

Legs

Although not strictly necessary, it will be easier to use the router sled if the frame is equipped with legs, as shown in Figure 9. Diagonal bracing is strongly recommended.

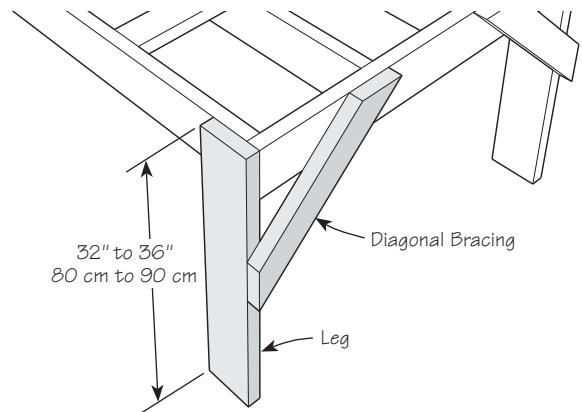

Figure 9: Legs with diagonal bracing added to frame.

Risers

Four risers are used to locate the tube rails. Make each riser about 16" (40 cm) tall. Any extra length will simply hang below the frame.

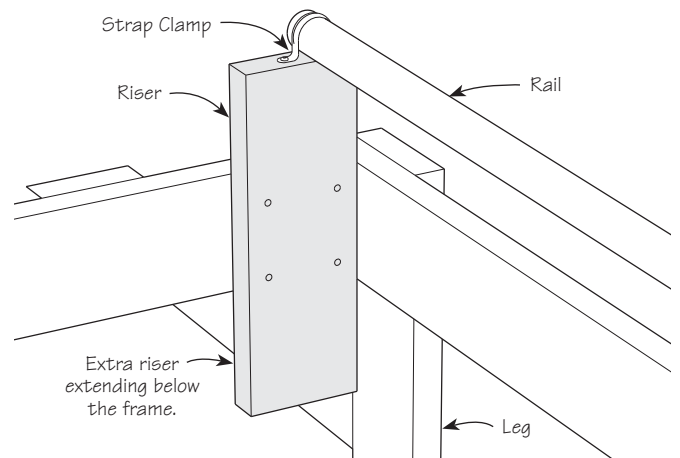

Figure 10: Risers fastened to the frame with screws.

Fasten the risers to the frame with screws in such a way that they can easily be adjusted to accommodate workpieces of varying thickness. A good initial riser height places the underside of the rails $3\frac{3}{4}$ " (9.5 cm) above the highest point on your workpiece.

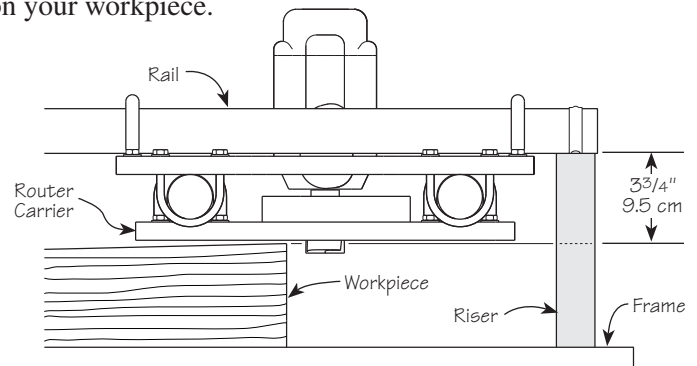

Figure 11: Riser height dependent on workpiece thickness.

Secure the rails to the risers with strap clamps (available where tube is sold).

Assembling the Router Sled onto the Rigid Frame

Rails

1. Secure one end of a rail to its corresponding riser using a strap clamp. The exact location isn't critical at this point, but aligning the strap clamp to the outside of the riser is a good starting point.

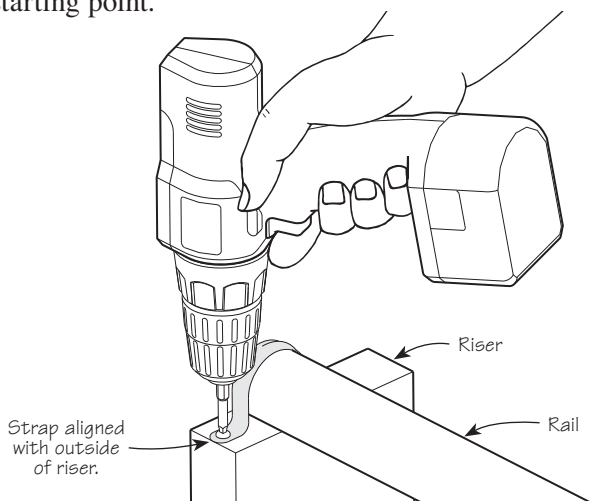

Figure 12: Aligning the strap clamp to the outside of the riser.

2. Slide a trunnion assembly onto the unsecured end of the rail, as shown in Figure 13.

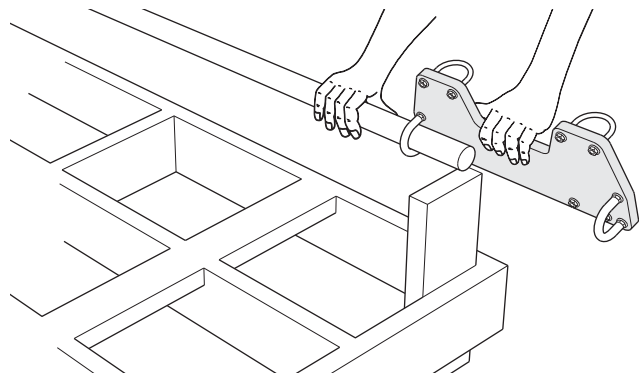

Figure 13: Installing trunnion assembly onto the rail tube.

3. When the trunnion is level, the glides should be facing up and the extension tabs facing out, as shown in Figure 14.

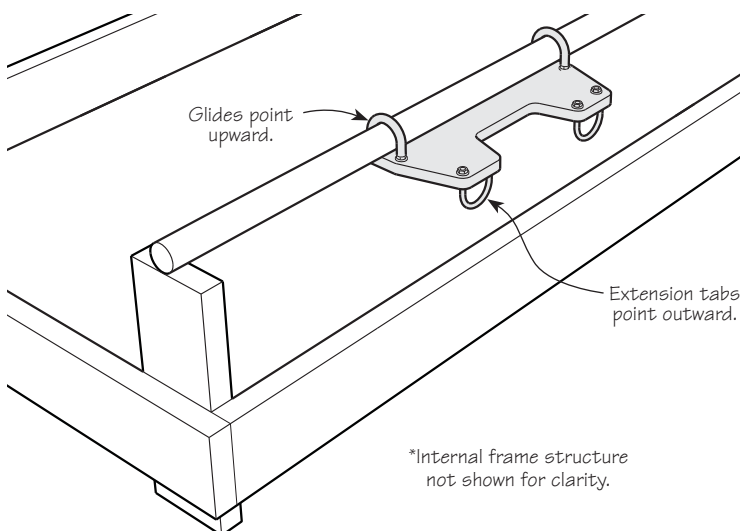

Figure 14: Trunnion assembly installed on rail.

4. Secure the other end of the rail to its riser with a second strap clamp. Repeat for the second rail, making sure that the two rails are parallel upon completion.
5. Check the movement of each trunnion. There should be a small amount of clearance between the top of the trunnion and the underside of the glide. If the rails leave rub marks on the trunnions, adjust the height of the glide assemblies until the rails clear the trunnions.

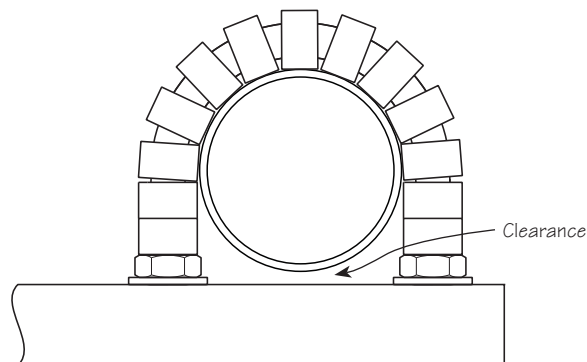

Figure 15: Clearance between the tube and the trunnion.

Gantry

1. Slide both trunnions to the same end of the rigid frame.

Note: To avoid the risk of accidentally knocking or dropping your router through the frame, remove your router from the carrier for this step.

2. Place the carrier between the trunnions, aligning the glide assemblies on the router carrier with the U-bolts under the trunnions.
3. Feed one of the gantry tubes through two U-bolts on one trunnion, through two glides on the router carrier, and then through two U-bolts on the other trunnion. Do not tighten any nuts yet. Feed the second gantry tube in the same manner.

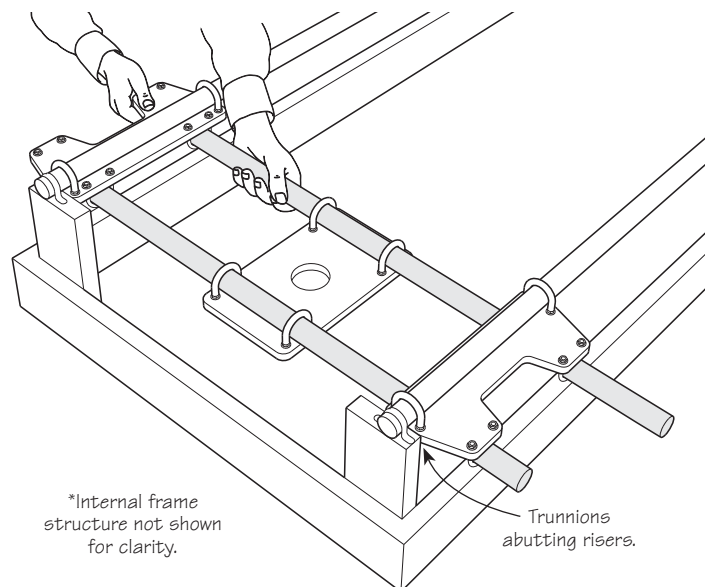

Figure 16: Inserting the gantry tubes through the trunnions and router carrier.

- Pull both trunnions firmly up against the risers at one end of the frame.
- Tighten all eight U-bolt nuts to lock the entire gantry together, making sure to tighten both nuts on a shared U-bolt equally to minimize the risk of imparting twist.

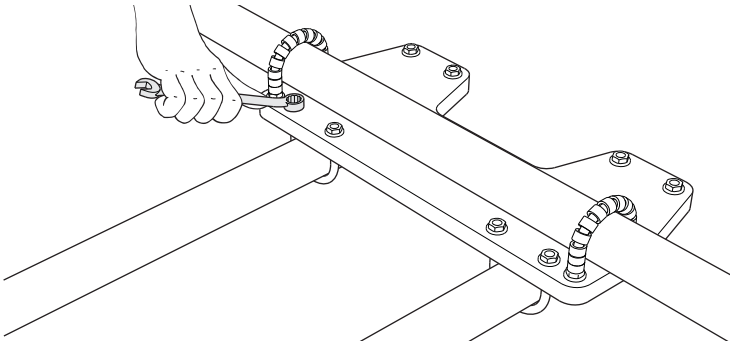

Figure 17: Tightening the U-bolt nuts.

- Check that the carrier slides along the gantry tubes smoothly. If it does not, adjust the glides in the same manner as was done for the trunnions.
- Remount your router.

Verifying the Set-Up

Before using the router sled, slide the gantry along the rails from one end of the frame to the other, and back several times. Also slide the carrier along the gantry. Check to make sure that all glides are in contact with their corresponding rails and that nothing is binding. Some resistance in the trunnions is expected and desirable.

Make any tweaks or adjustments necessary.

Operation

 **Caution:** To use this product safely, *always* follow the safety instructions that came with your router. As with any power tool accessory, *always* wear eye protection and hearing protection. Bits are **extremely sharp**; handle with care.

Here are some tips that will ensure success with your first slab flattening experience.

Locating the Workpiece

Regardless of how you choose to restrain your workpiece, it ought to be located as close to one side as practical to eliminate the need for excessive reaching.

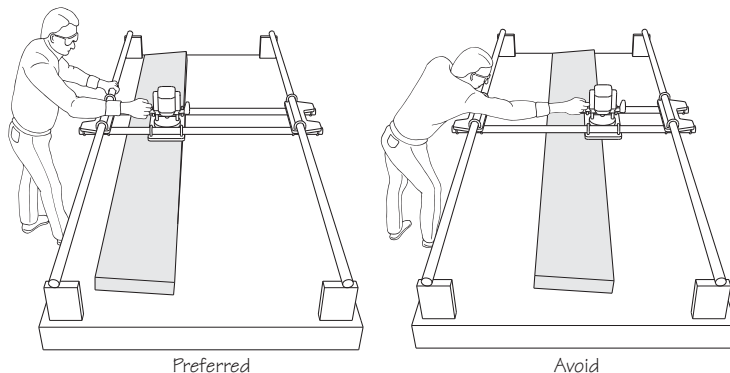

Figure 18: Avoid excessive reaching.

Holding the Workpiece

If you are working with roughly rectangular stock, such as reclaimed lumber, the flat blocks in the frame can be drilled with $\frac{3}{4}$ " or 20 mm holes to accept bench dogs.

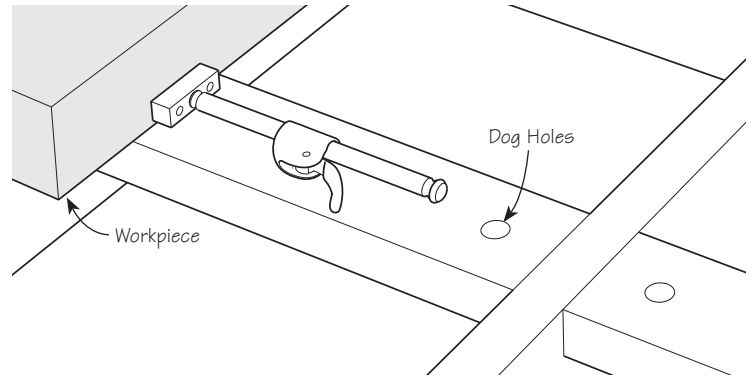

Figure 19: Using holes for bench dogs.

For slices of tree trunk, many blocks screwed directly to the frame provide effective positioning.

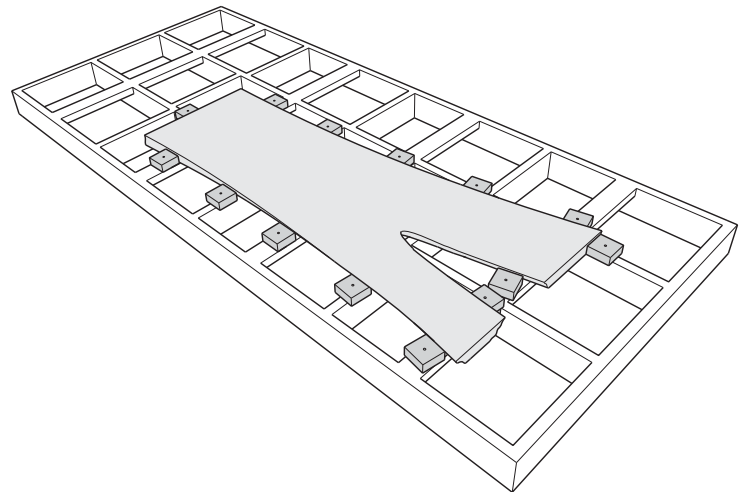

Figure 20: Securing awkwardly shaped workpiece to the frame.

Curved or twisted stock may require the use of wedges to prevent rocking. In this case, screw the wedges to the frame, and then use hot-melt glue to affix the stock to the wedges.

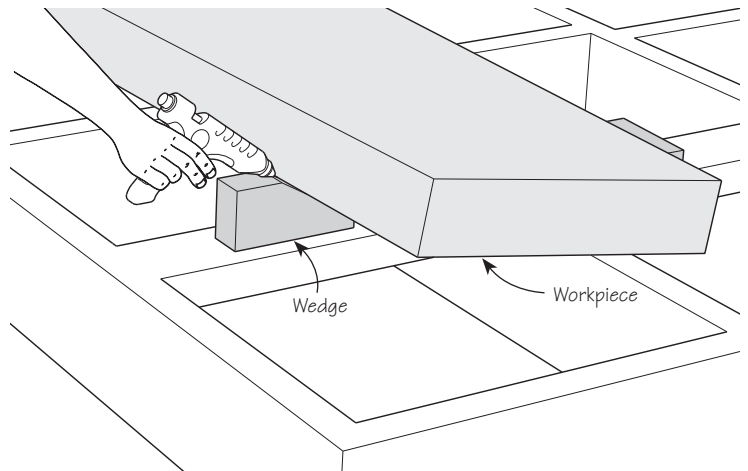

Figure 21: Securing a workpiece with hot-melt glue.

Overhead Power Cord

Cable management is a headache when using a router sled. We strongly recommend adding an arm to hold the power cable above the work.

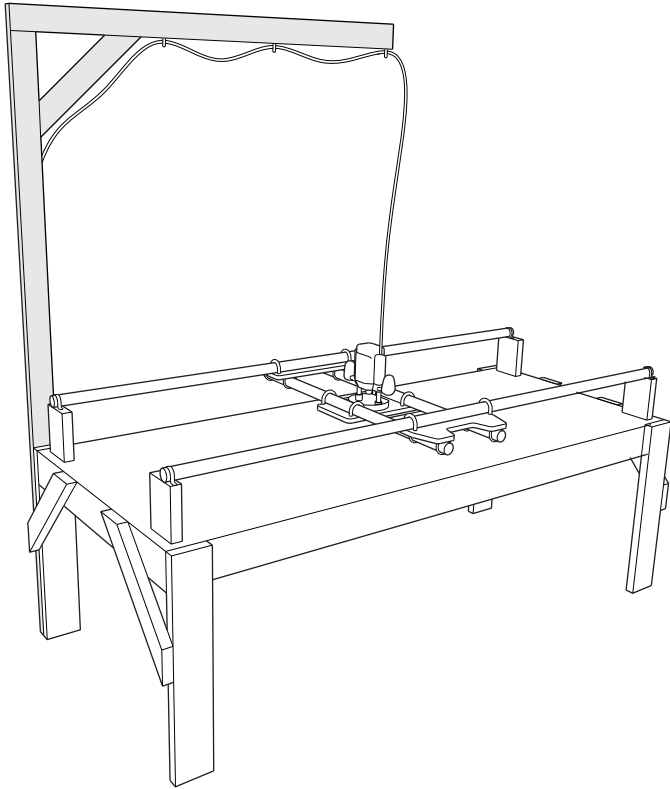

Figure 22: An arm provides overhead power cable management.

Routing

Slab flattening will remove a lot of material, which will be a workout for your router. We recommend working down in several $\frac{1}{4}$ " (6 mm) deep layers. Also, each pass should be no wider than half the diameter of the bit. These two settings result in the best balance of speed and safety.

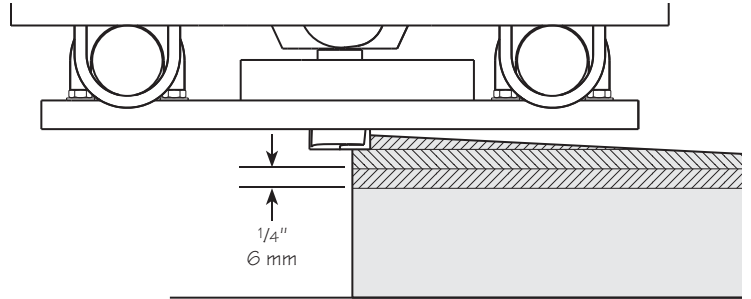

Figure 23: Recommended router bit depth.

The drag inherent in the glides resists the tendency of the router to pull itself along the workpiece. Since the rig can be used for both conventional and climb cutting, it is possible to cut on both the pull and push strokes.

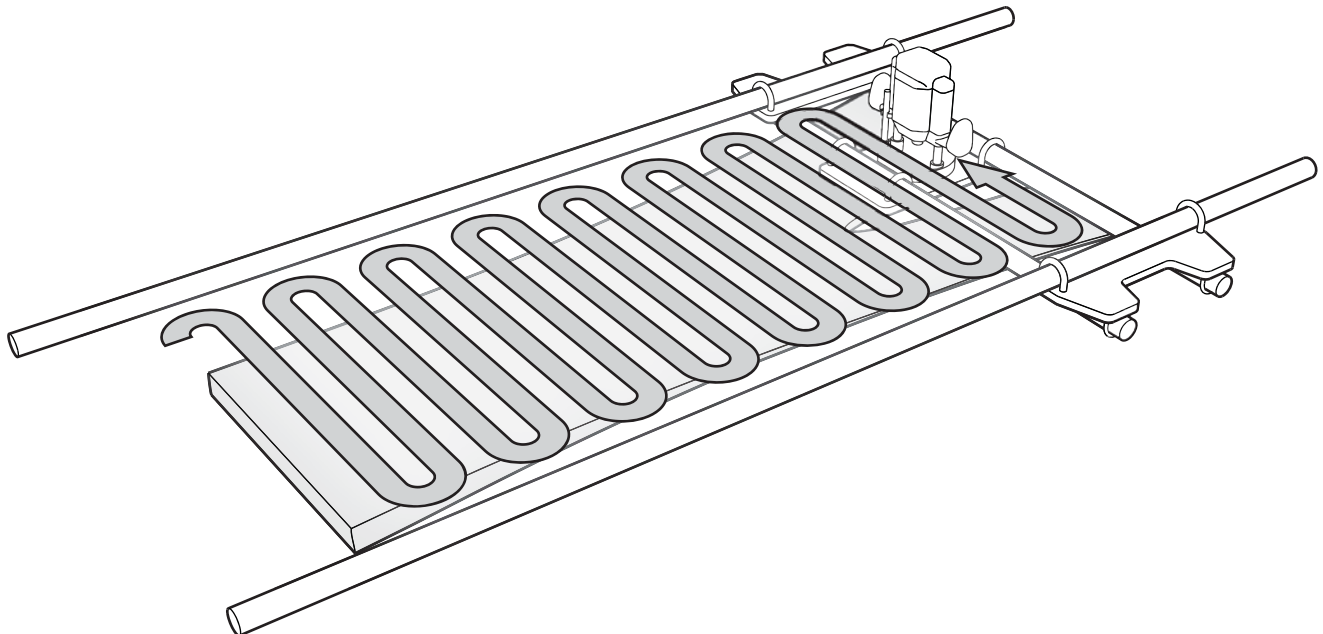
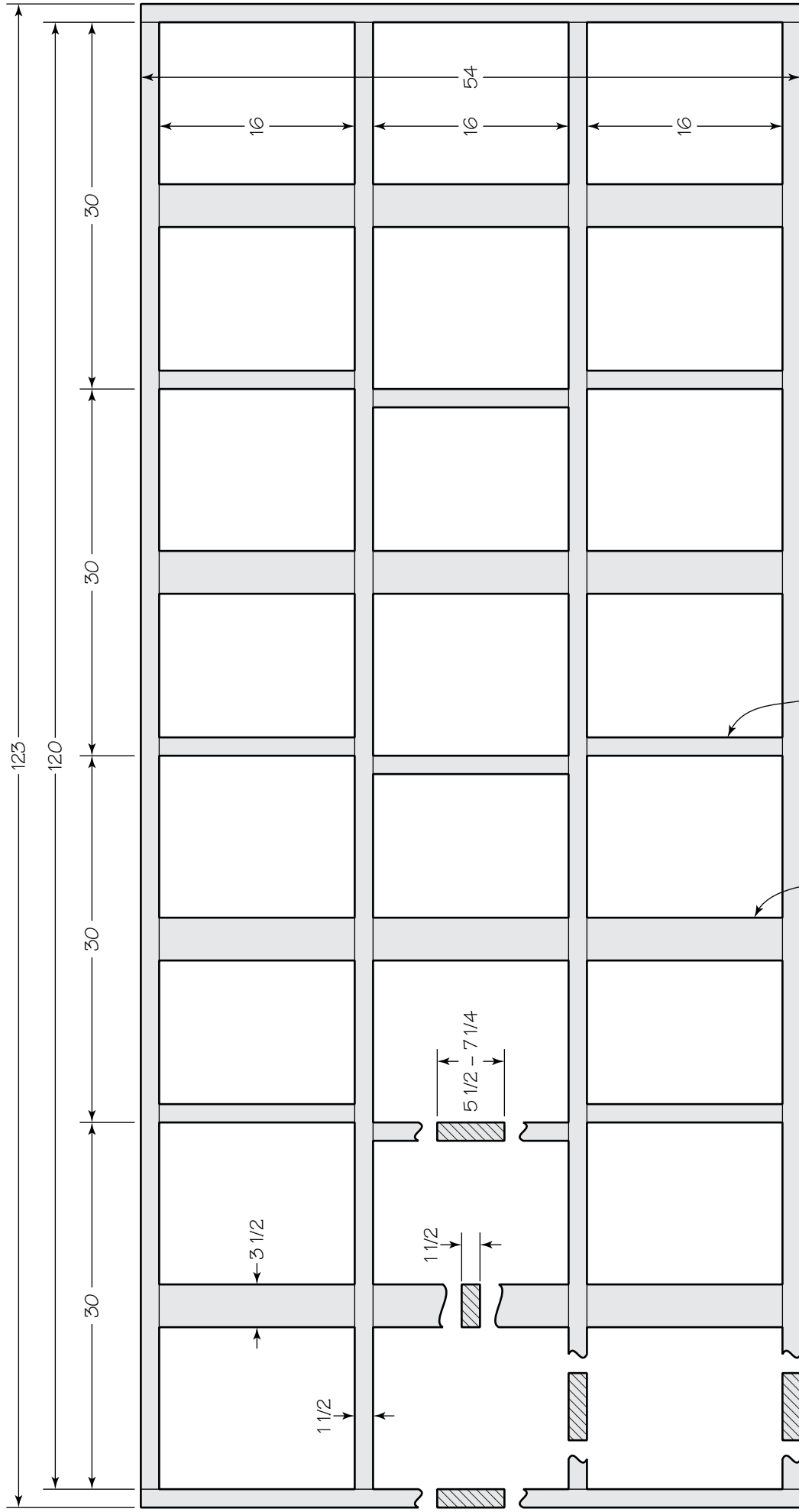

Figure 24: Flattening a slab on the router sled using both climb and conventional cutting.



Vertical blocking for rigidity.
Traverses verticales assurant la rigidité

Horizontal blocking for fixturing. Locate as needed.
Traverses horizontales pour fixer les dispositifs de serrage.
Les positionner selon les besoins



Rigid Frame for Router Sled
Plateforme pour chariot de dressage